

RoHS Compliant Product

A suffix of "-C" specifies halogen & lead-free

**TO-18**

**FEATURES**

Power dissipation

$P_{CM} : 1mW (T_{amb}=25^{\circ}C)$

Collector current

$I_{CM} : 1.5 A$

Collector-base voltage

$V_{(BR)CBO} : 180 V$

Collector-emitter voltage

$V_{CEO}$   
2SD669 : 120 V  
2SD669A : 160 V

Operating and storage junction temperature range

$T_J, T_{stg}: -55^{\circ}C \text{ to } +150^{\circ}C$

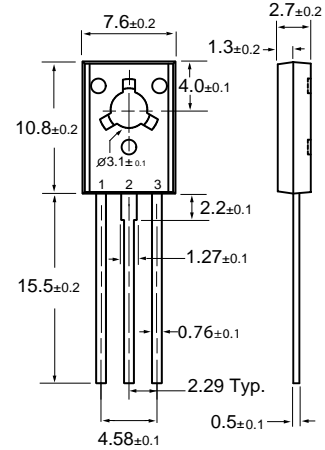

- 1: Emitter
- 2: Collector
- 3: Base

Dimensions in Millimeters

**CHARACTERISTICS ( $T_{amb}=25^{\circ}C$  unless otherwise specified)**

Parameter	Symbol	Test conditions	MIN	MAX	UNIT
Collector-base breakdown voltage	$V_{(BR)CBO}$	$I_C=1mA, I_E=0$	180		V
Collector-emitter breakdown voltage	$V_{(BR)CEO}$	$I_C=10mA, I_B=0$	2SD669 120 2SD669A 160		V
Collector-emitter breakdown voltage	$V_{(BR)EBO}$	$I_E=1mA, I_C=0$	5		V
Collector cut-off current	$I_{CBO}$	$V_{CB}=160V, I_E=0$		10	$\mu A$
Emitter cut-off current	$I_{EBO}$	$V_{EB}=4V, I_C=0$		10	$\mu A$
DC current gain	$h_{FE(1)}$ *	$V_{CE}=5V, I_C=150mA$	2SD669 60 2SD669A 60	320 200	
	$h_{FE(2)}$ *	$V_{CE}=5V, I_C=500mA$	30		
Collector-emitter saturation voltage	$V_{CE(sat)}$ *	$I_C=500mA, I_B=50mA$		1	V
Base-emitter voltage	$V_{BE}$ *	$V_{CE}=5V, I_C=150mA$		1.5	V
Transition frequency	$f_T$	$V_{CE}=5V, I_C=150mA$	140		MHz
Collector output capacitance	$C_{ob}$	$V_{CB}=10V, I_E=0, f=1MHz$	14		pF

\* The 2SD669 and 2SD669A are grouped by  $h_{FE1}$  as follows.

Rank	B	C	D
2SD 669	60 - 120	100 - 200	160 - 320
2SD669A	60 - 120	100 - 200	----

