

HIGH POWER SWITCHING REGULATOR APPLICATIONS.

FEATURES:

- High Voltage : $V_{CB0}=900V$
- High Peak Current Capability : $I_C(\text{Peak})=10A$
- High Speed Switching : $t_f=0.5\mu s$ (Max.)

MAXIMUM RATINGS (Ta=25°C)

CHARACTERISTIC	SYMBOL	RATING	UNIT
Collector-Base Voltage	V_{CB0}	900	V
Collector-Emitter Voltage	V_{CEO}	400	V
Collector-Base Voltage	V_{EBO}	7	V
Collector Current (DC)	I_C	6	A
Peak Collector Current	$I_{C \text{ peak}}$	10	A
Collector Power Dissipation (Tc=25°C)	P_C	50	W
Junction Temperature	T_j	150	°C
Storage Temperature Range	T_{stg}	-65~150	°C

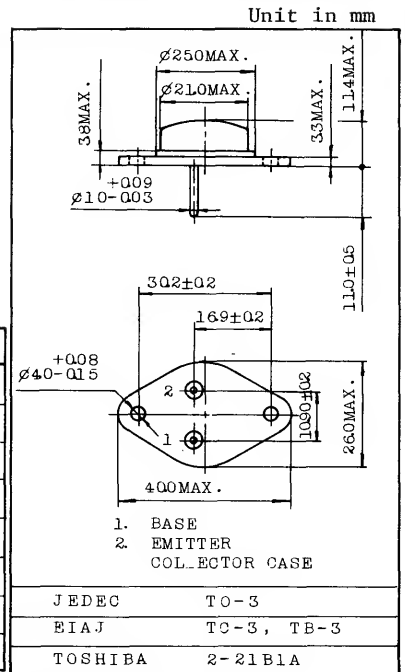

Mounting kit No. AC42C
Weight : 17g

ELECTRICAL CHARACTERISTICS (Ta=25°C)

CHARACTERISTIC	SYMBOL	TEST CONDITION	MIN.	TYP.	MAX.	UNIT
Collector Cut-off Current	I_{CB0}	$V_{CB}=900V, I_E=0$	-	-	1	mA
Emitter Cut-off Current	I_{EBO}	$V_{EB}=7V, I_C=0$	-	-	1	mA
DC Current Gain	$h_{FE(1)}$	$V_{CE}=5V, I_C=10mA$	8	-	-	
	$h_{FE(2)}$	$V_{CE}=5V, I_C=0.6A$	10	-	40	
Collector-Emitter Saturation Voltage	$V_{CE(sat)}$	$I_C=2.5A, I_B=0.5A$	-	-	5	V
Base-Emitter Saturation Voltage	$V_{BE(sat)}$	$I_C=2.5A, I_B=0.5A$	-	-	1.5	V
Collector Output Capacitance	C_{ob}	$V_{CB}=10V, I_E=0, f=1MHz$	-	75	-	pF
Transition Frequency	f_T	$V_{CE}=10V, I_C=0.1A$	-	5	-	MHz
Fall Time	t_f	$I_C=2.5A, I_{B1}=0.5A, I_{B2}=-1A$ (Fig.)	-	-	0.5	μs

Fig. t_f TEST CIRCUIT

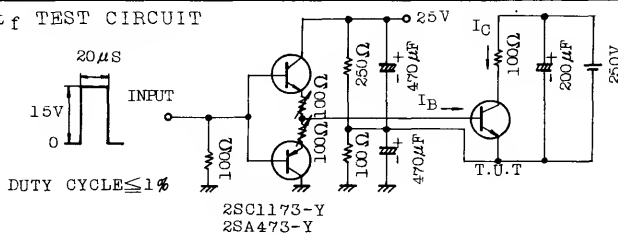

COLLECTOR CURRENT WAVEFORM

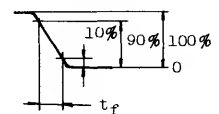

2SD811

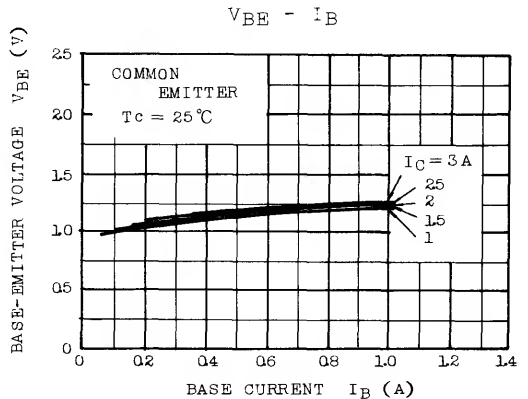
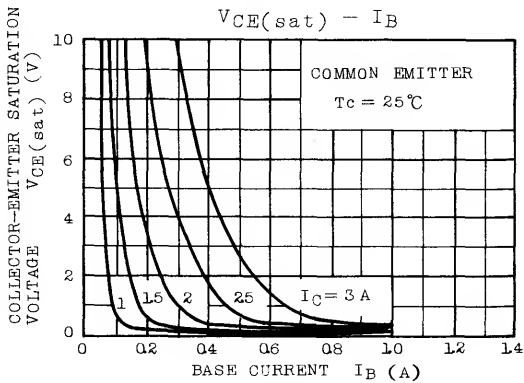
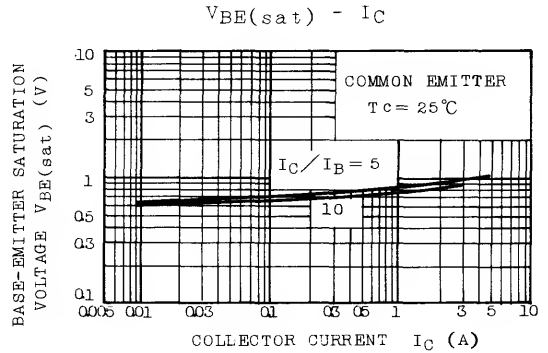
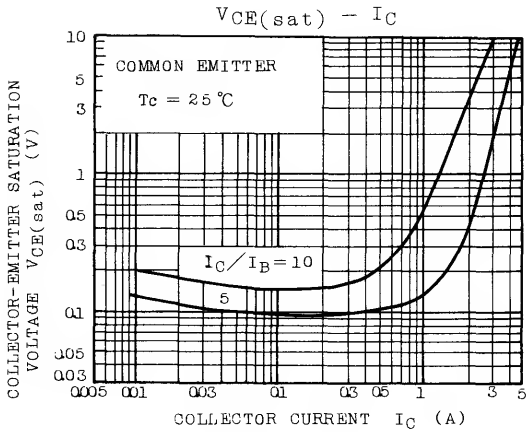
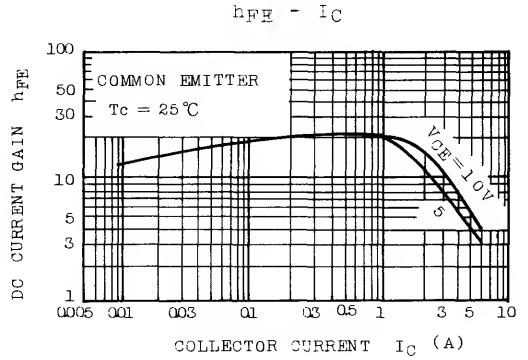
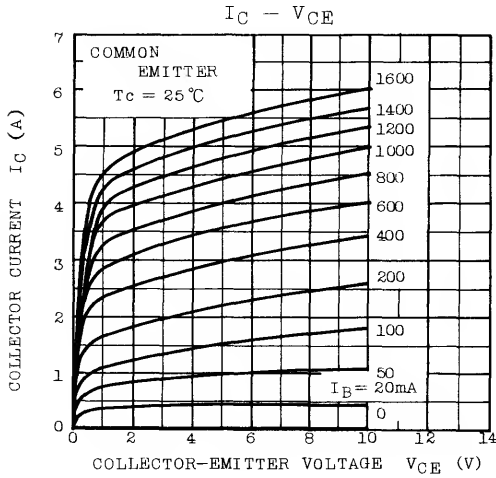

SWITCHING CHARACTERISTICS

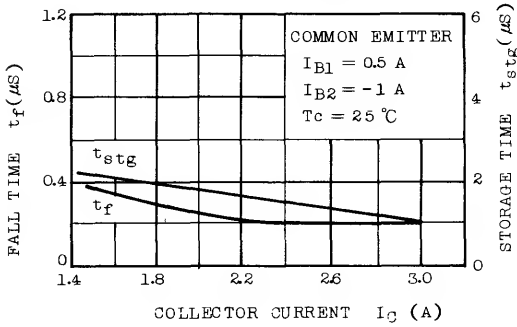

SWITCHING CHARACTERISTICS

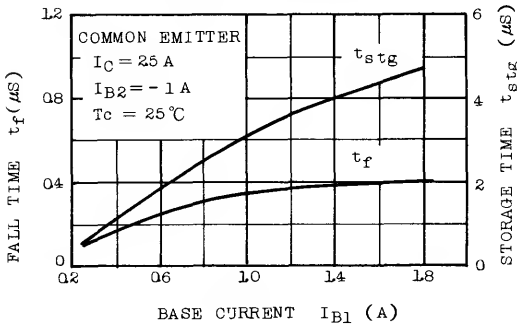

SWITCHING CHARACTERISTICS

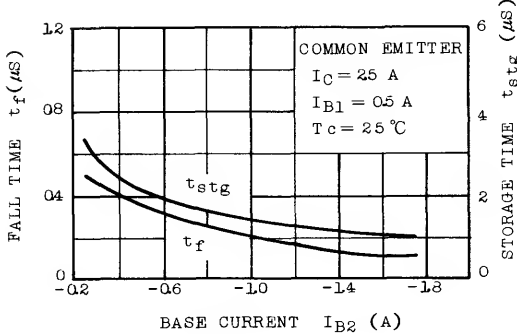

$P_C - T_a$

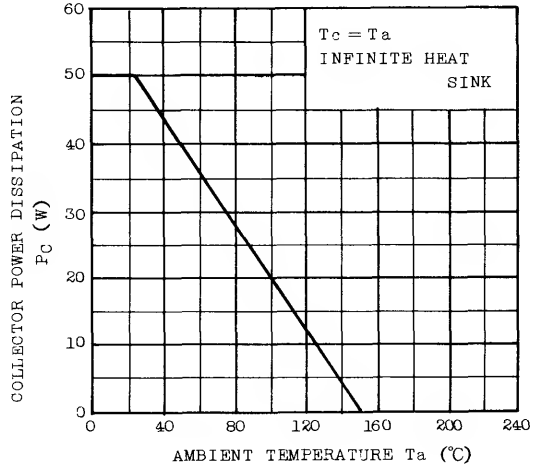

SAFE OPERATING AREA

