

**Silicon NPN Power Transistors**

**2SD845**

**DESCRIPTION**

www.datasheet4u.com

- With MT-200 package
- Complement to type 2SB755
- High transition frequency
- High breakdown voltage : $V_{CEO}=150V(\text{min})$

**APPLICATIONS**

- For power amplifier applications

**PINNING(see Fig.2)**

PIN	DESCRIPTION
1	Base
2	Collector;connected to mounting base
3	Emitter

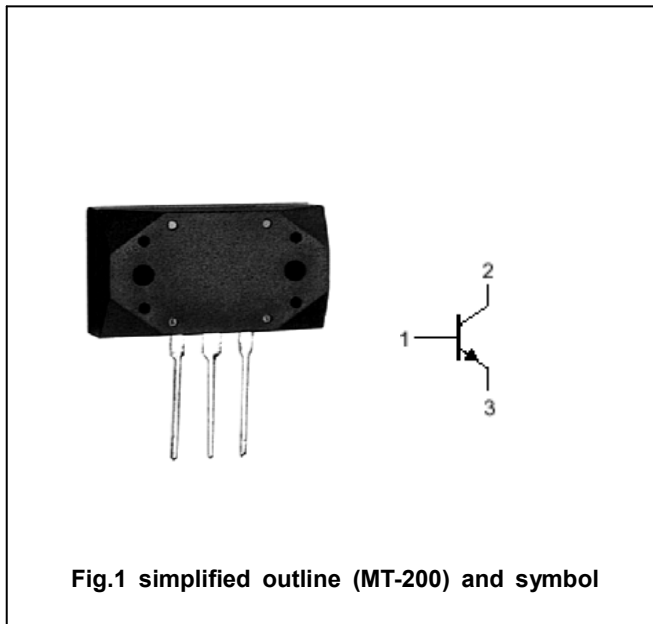

**Absolute maximum ratings (Ta=25°C)**

SYMBOL	PARAMETER	CONDITIONS	VALUE	UNIT
$V_{CBO}$	Collector-base voltage	Open emitter	150	V
$V_{CEO}$	Collector-emitter voltage	Open base	150	V
$V_{EBO}$	Emitter-base voltage	Open collector	5	V
$I_C$	Collector current		12	A
$I_B$	Base current		1.2	A
$P_C$	Collector power dissipation	$T_C=25^\circ\text{C}$	120	W
$T_j$	Junction temperature		150	°C
$T_{stg}$	Storage temperature		-55~150	°C

## Silicon NPN Power Transistors

2SD845

## CHARACTERISTICS

T<sub>j</sub>=25°C unless otherwise specified

www.datasheet4u.com

SYMBOL	PARAMETER	CONDITIONS	MIN	TYP.	MAX	UNIT
V <sub>(BR)CEO</sub>	Collector-emitter breakdown voltage	I <sub>C</sub> =0.1A; I <sub>B</sub> =0	150			V
V <sub>(BR)EBO</sub>	Emitter-base breakdown voltage	I <sub>E</sub> =10mA; I <sub>C</sub> =0	5			V
V <sub>CEsat</sub>	Collector-emitter saturation voltage	I <sub>C</sub> =5 A; I <sub>B</sub> =0.5 A			2.0	V
V <sub>BE</sub>	Base-emitter on voltage	I <sub>C</sub> =5A ; V <sub>CE</sub> =5V			1.5	V
I <sub>CBO</sub>	Collector cut-off current	V <sub>CB</sub> =150V; I <sub>E</sub> =0			-50	μA
I <sub>EBO</sub>	Emitter cut-off current	V <sub>EB</sub> =5V; I <sub>C</sub> =0			-50	μA
h <sub>FE</sub>	DC current gain	I <sub>C</sub> =1A ; V <sub>CE</sub> =5V	55		160	
f <sub>T</sub>	Transition frequency	I <sub>C</sub> =1A ; V <sub>CE</sub> =10V		20		MHz

◆ h<sub>FE</sub> classifications

R	O
55-110	80-160

Silicon NPN Power Transistors

2SD845

PACKAGE OUTLINE

www.datasheet4u.com

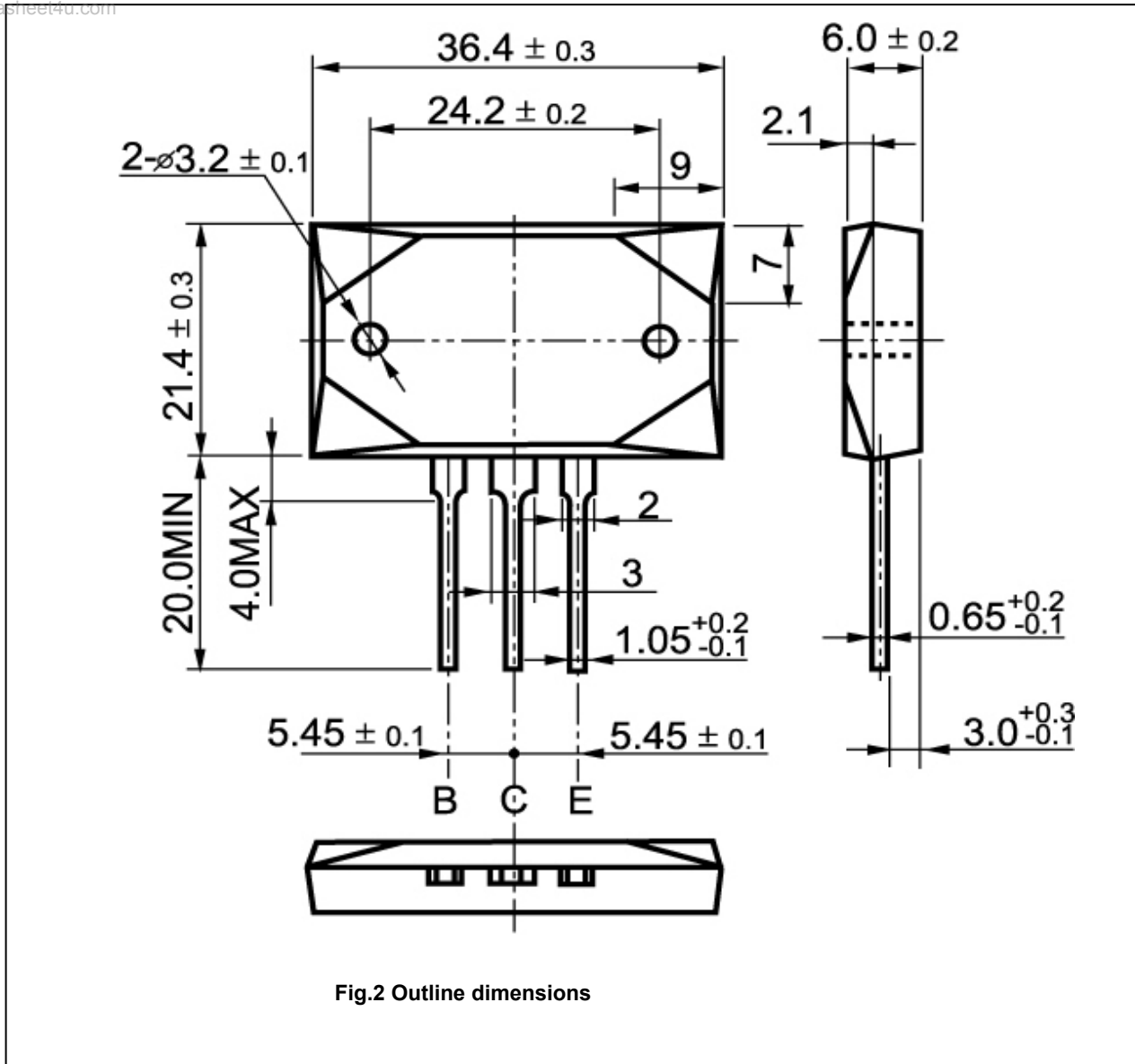

Fig.2 Outline dimensions