

isc N-Channel MOSFET Transistor

2SK1486

DESCRIPTION

- Drain Current  $-I_D=32A @ T_C=25^\circ C$
- Drain Source Voltage-  
:  $V_{DSS}=300$  (Min)

APPLICATIONS

- High speed power switching.

ABSOLUTE MAXIMUM RATINGS( $T_a=25^\circ C$ )

SYMBOL	PARAMETER	VALUE	UNIT
$V_{DSS}$	Drain-Source Voltage ( $V_{GS}=0$ )	300	V
$V_{GS}$	Gate-Source Voltage	$\pm 30$	V
$I_D$	Drain Current-continuous@ $T_C=25^\circ C$	32	A
$P_{tot}$	Total Dissipation@ $T_C=25^\circ C$	200	W
$T_j$	Max. Operating Junction Temperature	150	$^\circ C$
$T_{stg}$	Storage Temperature Range	-55~150	$^\circ C$

THERMAL CHARACTERISTICS

SYMBOL	PARAMETER	MAX	UNIT
$R_{th\ j-c}$	Thermal Resistance,Junction to Case	0.625	$^\circ C/W$
$R_{th\ j-a}$	Thermal Resistance,Junction to Ambient	35.7	$^\circ C/W$

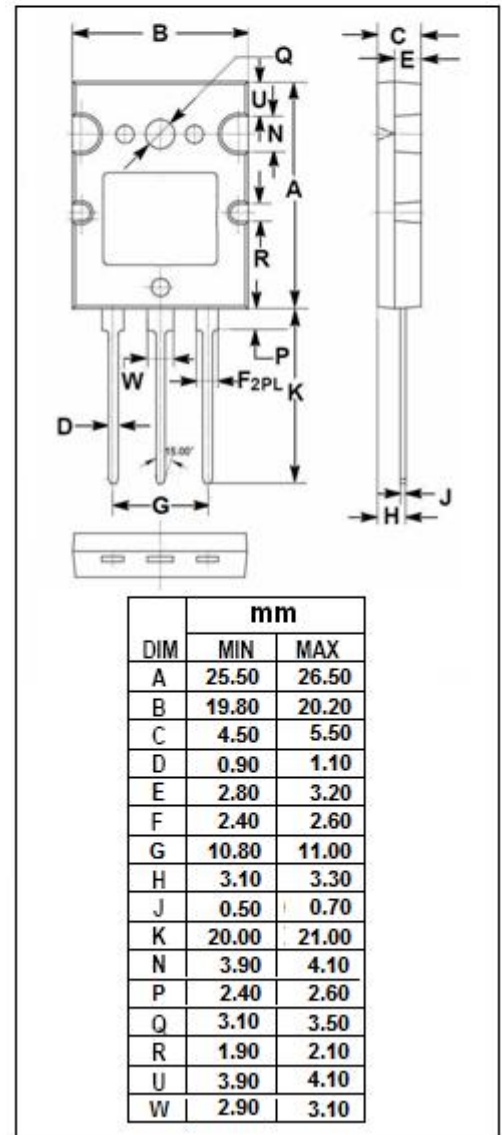
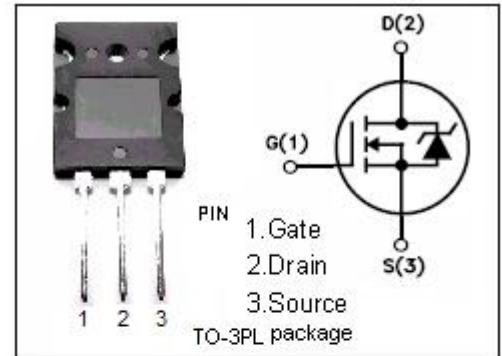

## isc N-Channel Mosfet Transistor

2SK1486

• ELECTRICAL CHARACTERISTICS (T<sub>C</sub>=25°C)

SYMBOL	PARAMETER	CONDITIONS	MIN	TYP	MAX	UNIT
V <sub>(BR)DSS</sub>	Drain-Source Breakdown Voltage	V <sub>GS</sub> =0; I <sub>D</sub> = 10mA	300			V
V <sub>GS(th)</sub>	Gate Threshold Voltage	V <sub>DS</sub> =10V; I <sub>D</sub> =1mA	2.0		4.0	V
R <sub>DS(on)</sub>	Drain-Source On-stage Resistance	V <sub>GS</sub> =10V; I <sub>D</sub> =16A		0.08	0.095	Ω
I <sub>GSS</sub>	Gate Source Leakage Current	V <sub>GS</sub> = ±30V; V <sub>DS</sub> = 0			± 100	nA
I <sub>DSS</sub>	Zero Gate Voltage Drain Current	V <sub>DS</sub> =300V; V <sub>GS</sub> = 0			300	uA
V <sub>SD</sub>	Diode Forward Voltage	I <sub>F</sub> =32A; V <sub>GS</sub> =0			1.8	V
t <sub>r</sub>	Rise time	V <sub>GS</sub> =10V; I <sub>D</sub> =16A; R <sub>L</sub> =50 Ω		255		ns
t <sub>on</sub>	Turn-on time			325		ns
t <sub>f</sub>	Fall time			280		ns
t <sub>off</sub>	Turn-off time			540		ns