

Fuji power MOSFET Specification

2SK1503-01

1. Scope

This specifies Fuji power MOSFET 2SK1503-01

2. Outline

- I) Construction N-channel enhancement mode power MOSFET
- II) Application for switching
- III) Outview TO-220 (MK5C27595)

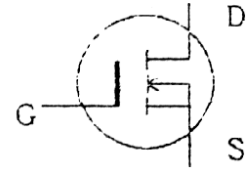

3. Absolute maximum ratings at Tc=25 °C (unless otherwise specified)

Description	Symbol	Characteristics	Unit	Remarks
Drain-source voltage	V _{DS}	500	V	
Drain-gate voltage	V _{DGR}	500	V	R _{GS} = 20 KΩ
Continuous Drain current	I _D	10	A	
Pulsed drain current	I _{Dpulse}	35	A	
Gate-source voltage	V _{GS}	± 30	V	
Maximum power dissipation	P _D	80	W	
Operating and storage temperature range	T _{ch}	150	°C	
	T _{stg}	-55 ~ +150	°C	

4. Electrical characteristics at Tc=25°C (unless otherwise specified)

Static ratings

Description	Symbol	Conditions	Characteristics			Unit
			Min.	Typ.	Max.	
Drain-source breakdown voltage	B V _{DSS}	I _D = 1 mA V _{GS} = 0 V	500			V
Gate threshold voltage	V _{GS(th)}	I _D = 1 mA V _{DS} = V _{GS}	2.5	3.5	5.0	V
Zero gate voltage drain current	I _{DSS}	V _{DS} = 500V V _{GS} = 0V		10	500	μA
	I _{DSS}					
Gate-source leakage current	I _{GSS}	V _{GS} = ±30V V _{DS} = 0V		10	100	nA
Drain-source on-state resistance	R _{DS(on)}	I _D = 5 A V _{GS} = 10 V		0.7	0.9	Ω

This material and the information herein is the property of Fuji Electric Co., Ltd. They shall be neither reproduced, copied, lent, or disclosed in any way whatsoever for the use of any third party, nor used for the manufacturing purposes without the express written consent of Fuji Electric Co., Ltd.

DATE	NAME	APPROVED	Fuji Electric Co., Ltd.	
DRAWN Feb. 21 '92	Y. Maruyama		DWG. NO.	MT5F4259 1/9
CHECKED Feb. 24 '92	M. Kojisawa			
REVISIONS	M. Suganuma			

Dynamic ratings

Description	Symbol	Conditions	Characteristics			Unit
			Min.	Typ.	Max.	
Forward transconductance	g_{fs}	$I_D = 5 A$ $V_{DS} = 25 V$	4.0	6.5		S
Input capacitance	C_{iss}	$V_{DS} = 25 V$ $V_{GS} = 0 V$ $f = 1 MHz$		1200	1800	pF
Output capacitance	C_{oss}			160	240	pF
Reverse transfer capacitance	C_{rss}			70	100	pF
Turn-on time	$t_{d(on)}$	$V_{CC} = 300V$ $V_{GS} = 10V$ $I_D = 10A$ $R_{GS} = 25\Omega$		30	45	ns
	t_r			80	120	ns
Turn-off time	$t_{d(off)}$			160	240	ns
	t_f			80	120	ns

Reverse diode

Description	Symbol	Conditions	Characteristics			Unit
			Min.	Typ.	Max.	
Avalanche capability	I_{AV}	$L = 100 \mu H, T_{ch} = 25^\circ C$ *see Fig1 and 2	10			A
Continuous reverse drain current	I_{DR}	$T_c = 25^\circ C$			10	A
Pulsed reverse drain current	I_{DRM}	$T_c = 25^\circ C$			35	A
Diode forward on-voltage	V_{SD}	$I_F = 2 \times I_{DR}$ $V_{GS} = 0 V, T_{ch} = 25^\circ C$		1.1	1.65	V
Reverse recovery time	t_{rr}	$I_F = I_{DR}$ $-dI_F/dt = 100A/\mu S$ $T_{ch} = 25^\circ C$		500		ns
Reverse recovery charge	Q_{rr}				3.5	

5. Thermal resistance

Description	Symbol	Conditions	Characteristics			Unit
			Min.	Typ.	Max.	
Thermal resistance	$R_{th_{ch-c}}$				1.56	$^\circ C/W$
	$R_{th_{ch-a}}$				75.0	$^\circ C/W$

DATE	NAME	APPROVED	Fuji Electric Co.,Ltd.	
DRAWN	-		DWG.NO.	MT5 F4259
CHECKED	-			
REVISIONS				

This material and the information herein is the property of Fuji Electric Co. Ltd. They shall be neither reproduced, copied, lent, or disclosed in any way whatsoever for the use of any third party nor used for the manufacturing purposes without the express written consent of Fuji Electric Co. Ltd.

Fig.1 Test circuit

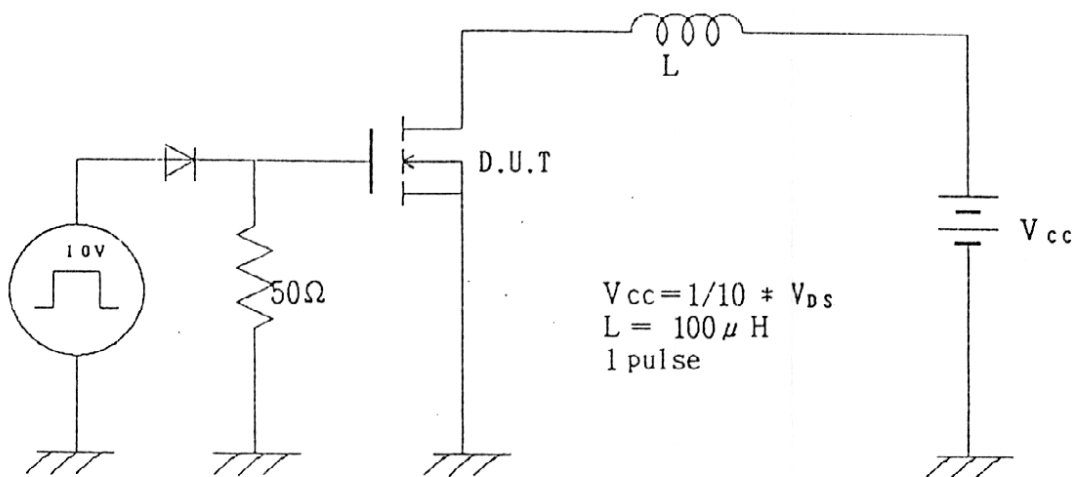
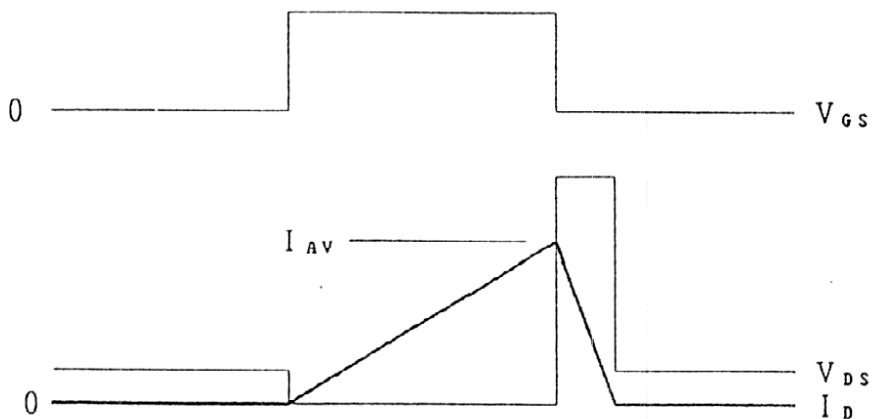

Fig.2 Operating waveforms



This material and the information herein is the property of Fuji Electric Co. Ltd. They shall be neither reproduced, copied, lent, or disclosed in any way whatsoever, for the use of any third party nor used for the manufacturing purposes without the express written consent of Fuji Electric Co., Ltd.

	DATE	NAME	APPROVED	Fuji Electric Co.,Ltd.
DRAWN	- -			DWG.NO. MT5 F 4259 3/9
CHECKED	- -			
REVISIONS				

Power Dissipation
 $PD=f(TC)$

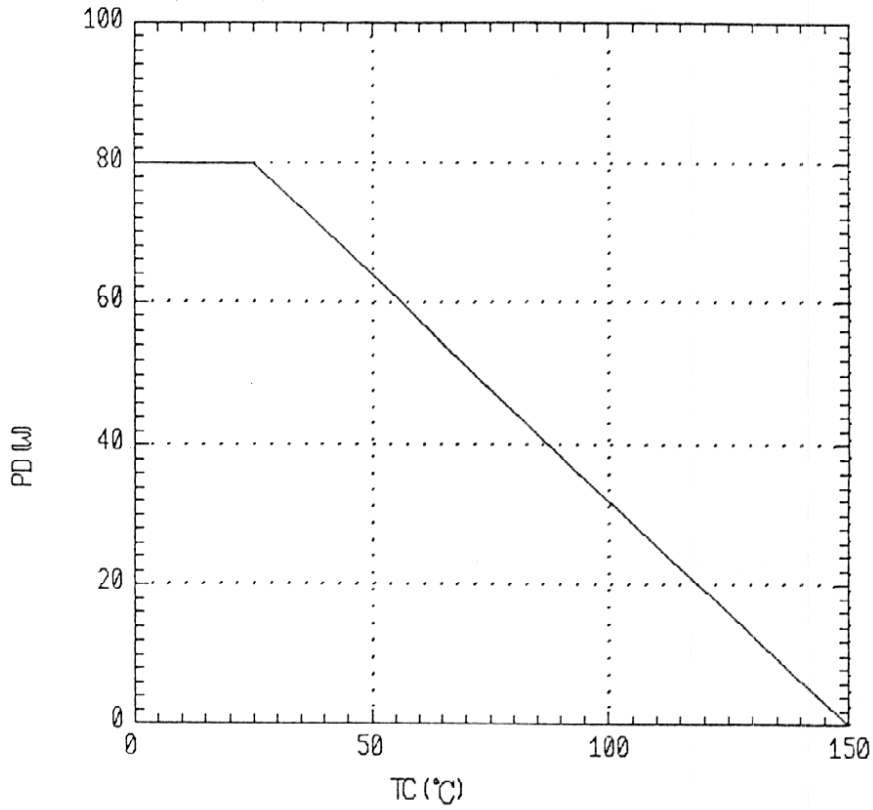

Safe operating area
 $ID=f(VDS): D=0.01, Tc=25^{\circ}C$

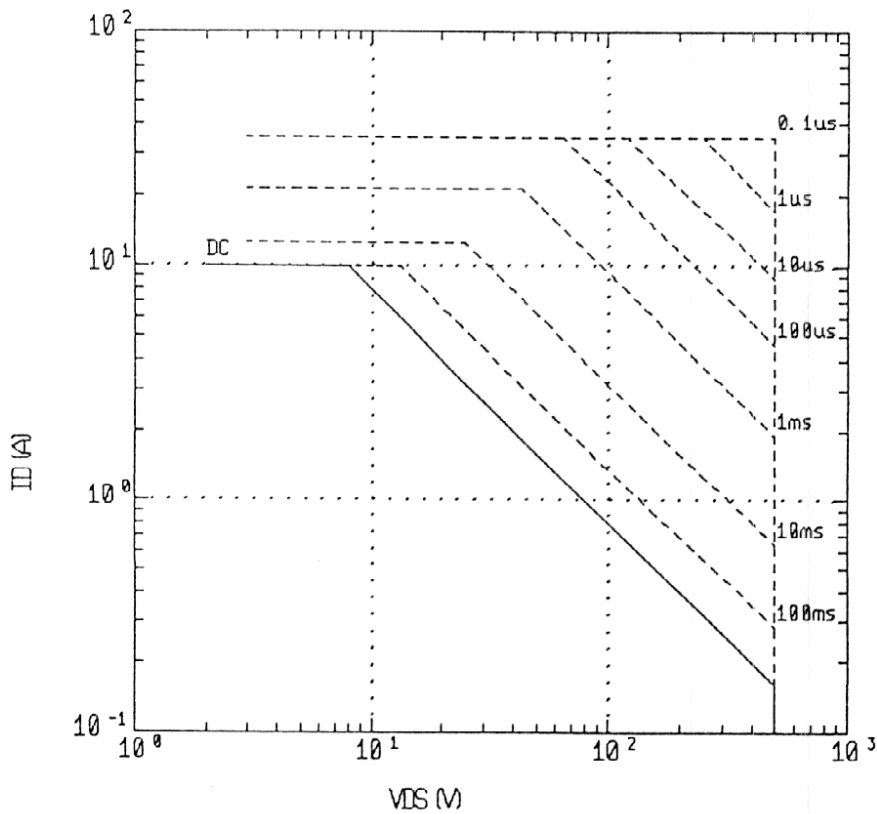

This material and the information herein is the property of Fuji Electric Co. Ltd. They shall be neither reproduced, copied, lent, or disclosed in any way whatsoever for the use of any third party nor used for the manufacturing purposes without the express written consent of Fuji Electric Co. Ltd.

	DATE	NAME	APPROVED	Fuji Electric Co.,Ltd.	
DRAWN	- -			DWG. NO.	MT5 F 4259
CHECKED	- -				
REVISIONS					

Typical output characteristics
 $I_D = f(V_{DS}) : 80 \mu s$ pulse test, $T_{ch} = 25^\circ C$

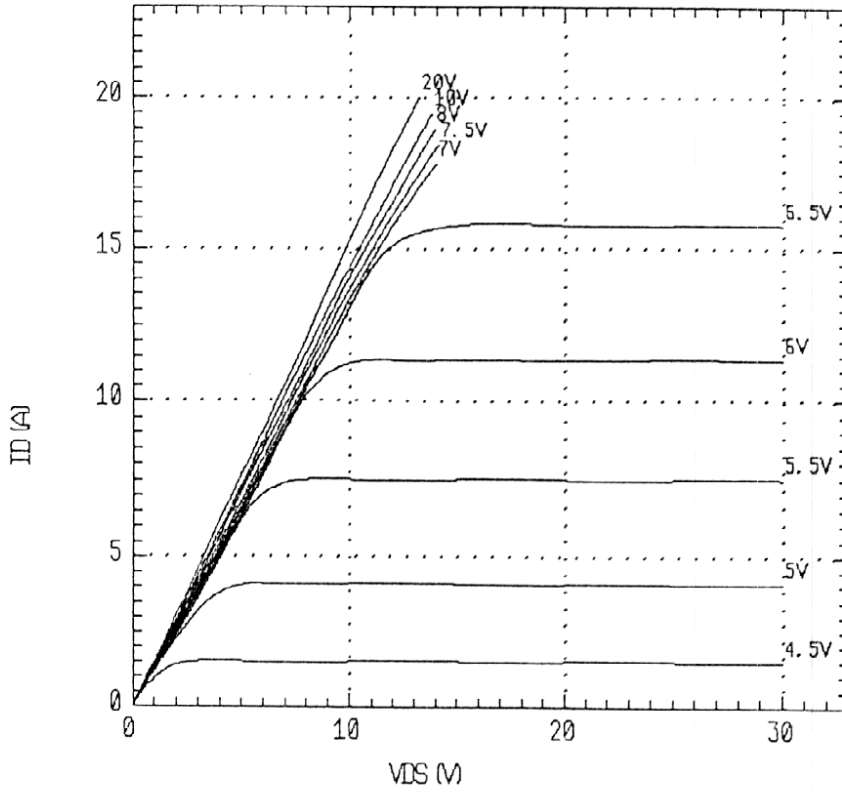

Typical Transfer Characteristics
 $I_D = f(V_{GS}) : 80 \mu s$ pulse test, $V_{DS} = 25V$, $T_{ch} = 25^\circ C$

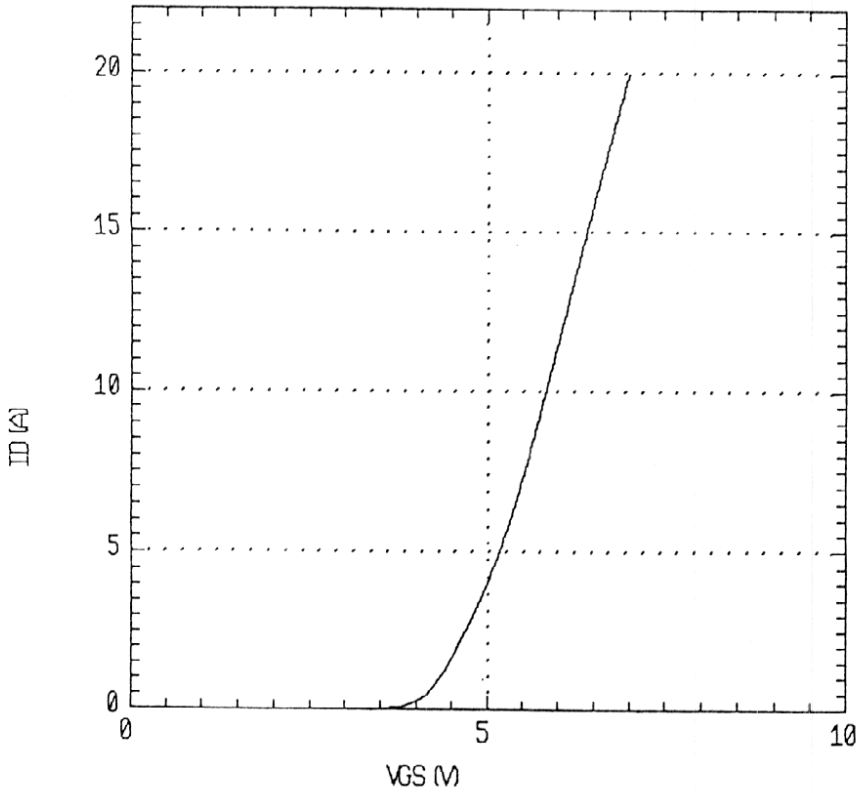

This material and the information herein is the property of Fuji Electric Co., Ltd. They shall be neither reproduced, copied, lent, or disclosed in any way whatsoever for the use of any third party, nor used for the manufacturing purposes without the express written consent of Fuji Electric Co., Ltd.

	DATE	NAME	APPROVED	Fuji Electric Co., Ltd.	
DRAWN	- -				
CHECKED	- -			DWG. NO.	MT5 F 4259
REVISIONS					5/9

Typical Transconductance
 $g_{fs} = f(I_D)$: $80 \mu s$ pulse test, $V_{DS} = 25V$, $T_{ch} = 25^\circ C$

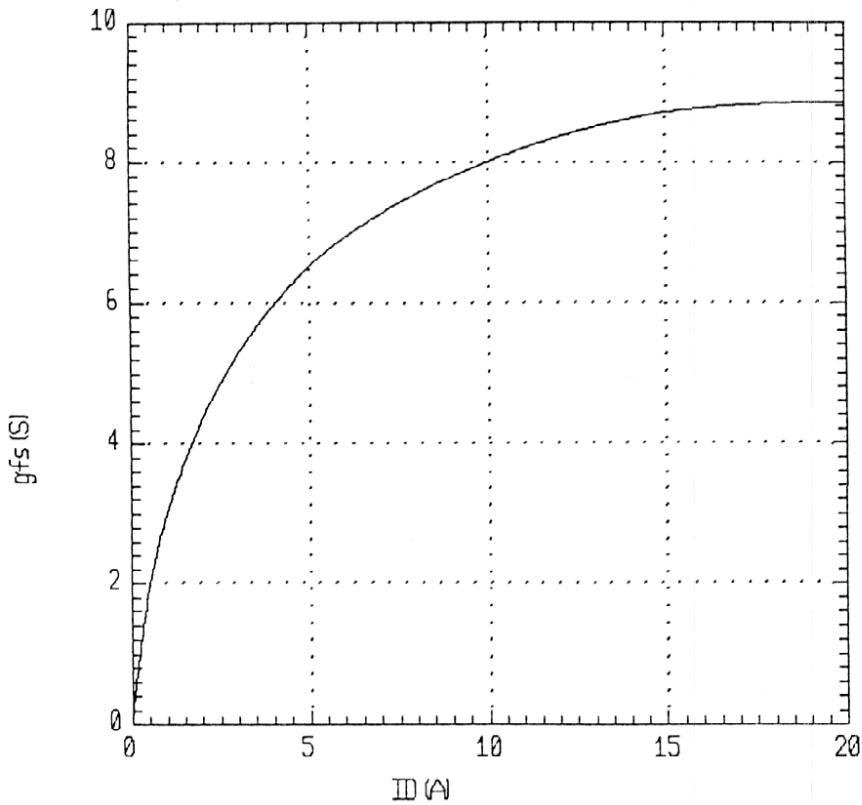

Typical Drain-source on-state resistance
 $R_{DS(on)} = f(I_D)$: $80 \mu s$ pulse test, $T_{ch} = 25^\circ C$

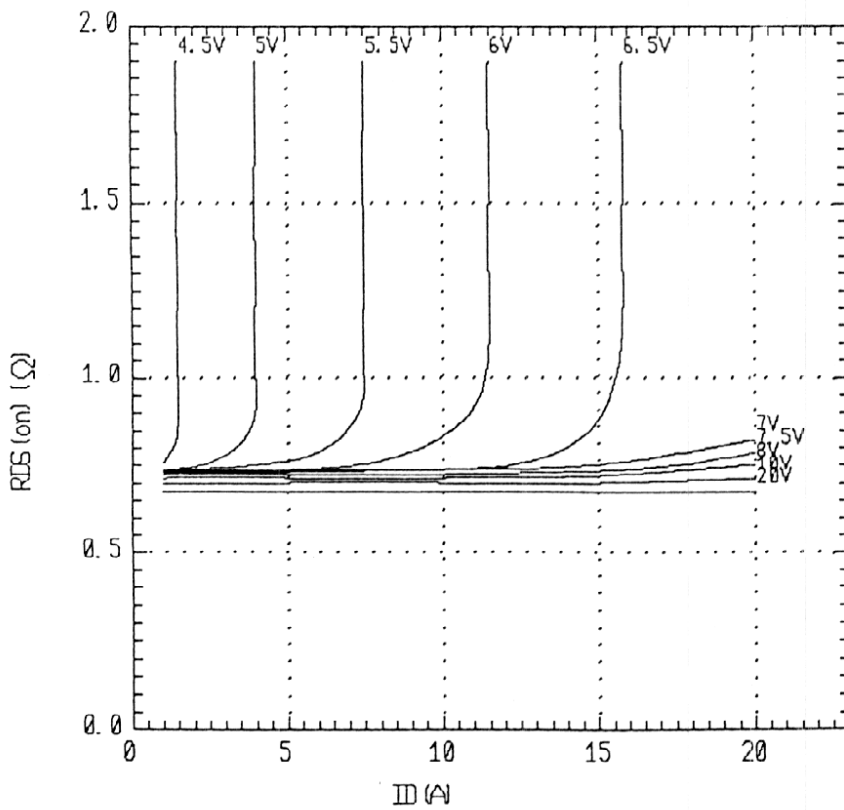

This material and the information herein is the property of Fuji Electric Co., Ltd. They shall be neither reproduced, copied, lent, or disclosed in any way whatsoever for the use of any third party, nor used for the manufacturing purposes without the express written consent of Fuji Electric Co., Ltd.

	DATE	NAME	APPROVED
DRAWN	- -		
CHECKED	- -		
REVISIONS			

Fuji Electric Co., Ltd.

MT5 F 4259

6/9

This material and the information herein is the property of Fuji Electric Co., Ltd. They shall be neither reproduced, copied, lent, or disclosed in any way whatsoever for the use of any third party nor used for the manufacturing purposes without the express written consent of Fuji Electric Co., Ltd.

Drain-source on-state resistance
 $R_{DS(on)} = f(T_{ch}) : I_D = 5A, V_{GS} = 10V$

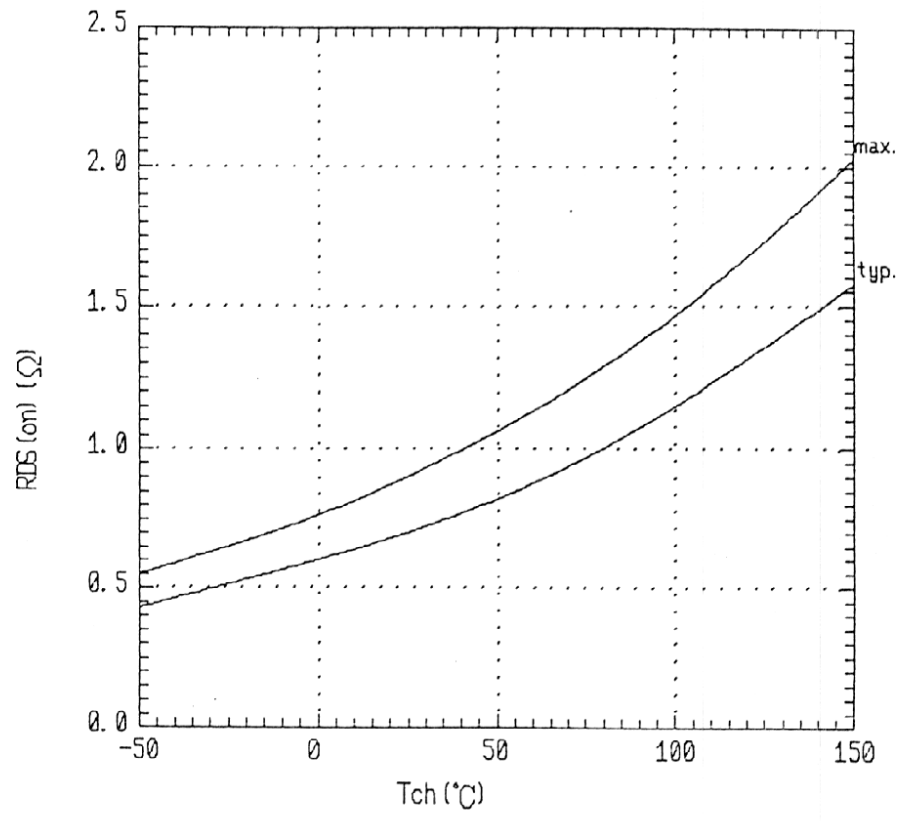

Gate threshold voltage
 $V_{GS(th)} = f(T_{ch}) : V_{DS} = V_{GS}, I_D = 1mA$

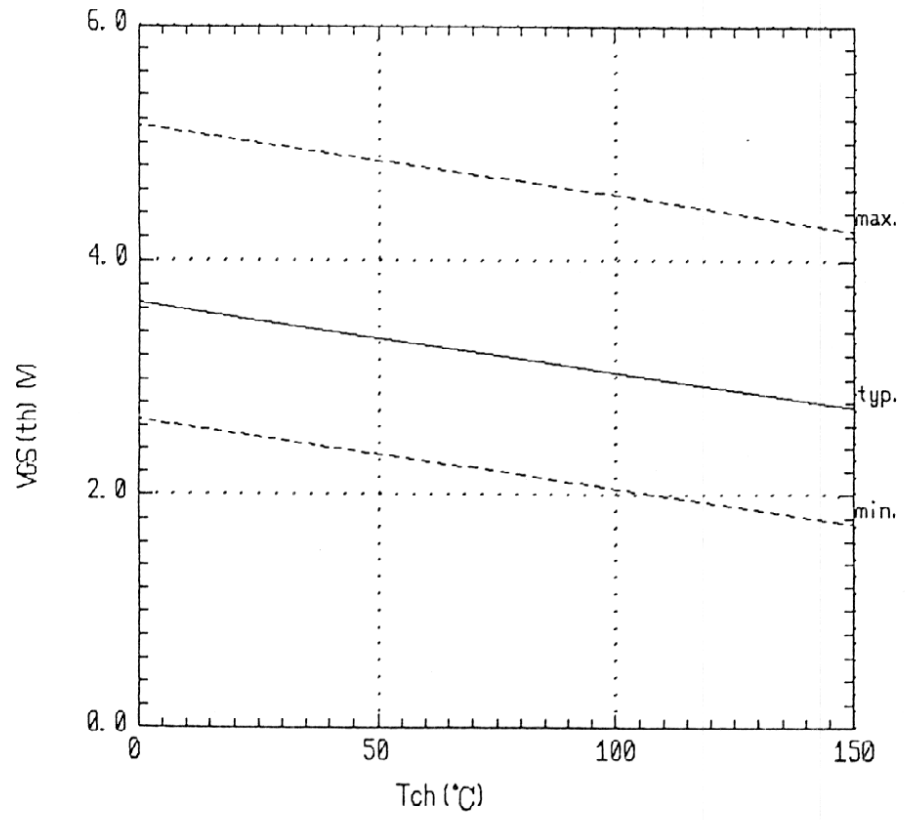

	DATE	NAME	APPROVED	Fuji Electric Co.,Ltd.	
DRAWN	-				
CHECKED	-			DWG. NO.	MT5 F 4259
REVISIONS					7/9

Typical gate charge characteristics
 $V_{GS} = f(Q_g) : I_D = 10A$

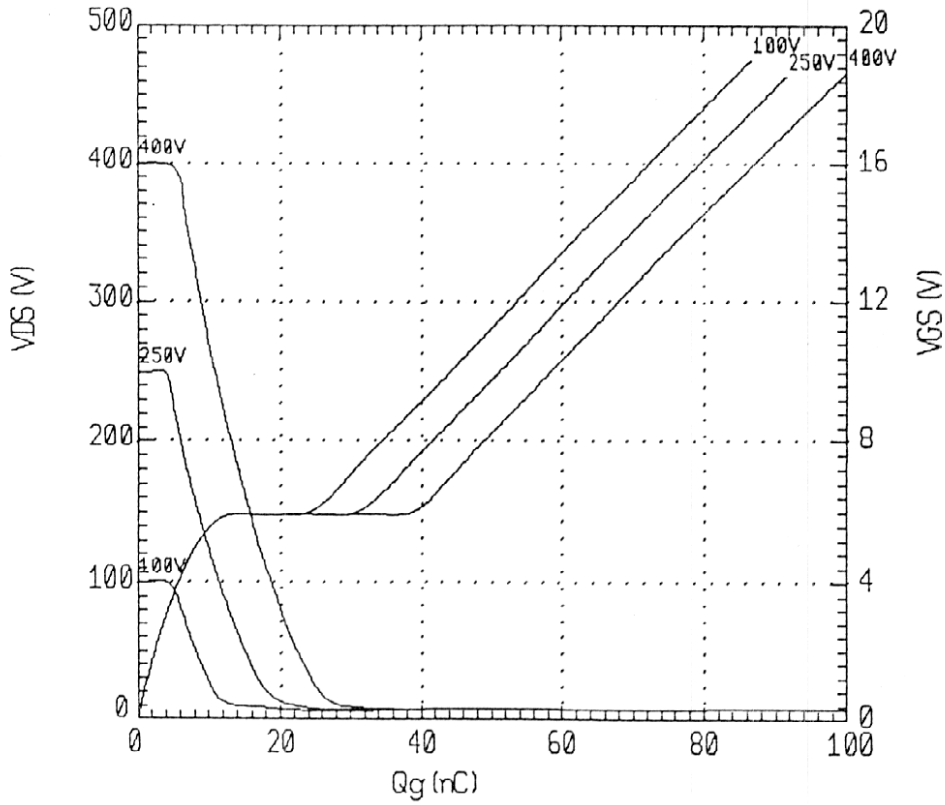

Typical capacitances
 $C = f(V_{DS}) : V_{GS} = 0V, f = 1MHz$

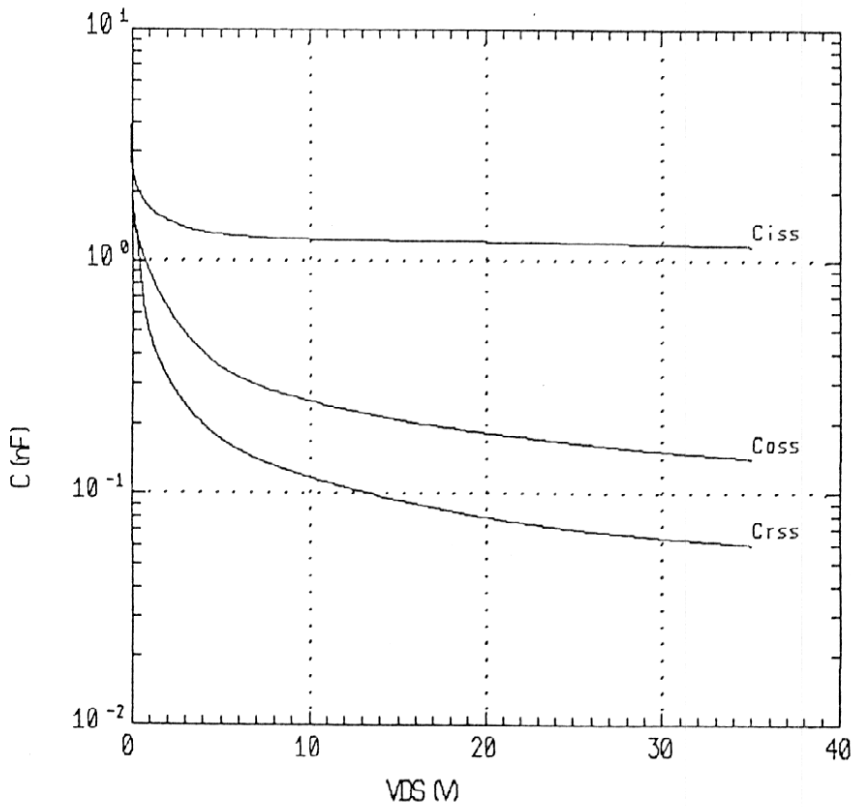

This material and the information herein is the property of Fuji Electric Co., Ltd. They shall be neither reproduced, copied, lent, or disclosed in any way whatsoever for the use of any third party nor used for the manufacturing purposes without the express written consent of Fuji Electric Co., Ltd.

	DATE	NAME	APPROVED
DRAWN	- -		
CHECKED	- -		

Fuji Electric Co., Ltd.

DWG. NO.

MT5 F 4259

8/9

Forward characteristic of reverse diode
 $I_F = f(V_{SD}) : 80 \mu s$ pulse test, $T_{ch} = 25^\circ C$

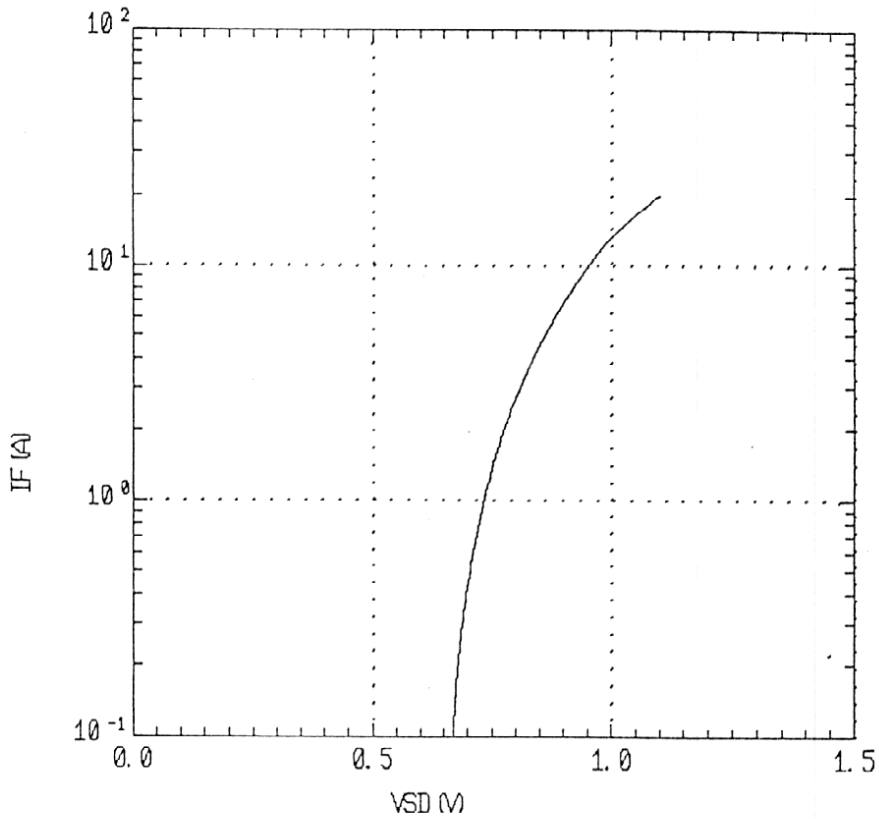

Transient thermal impedance $Z_{thch-c} = f(t)$ parameter: $D = t/T$

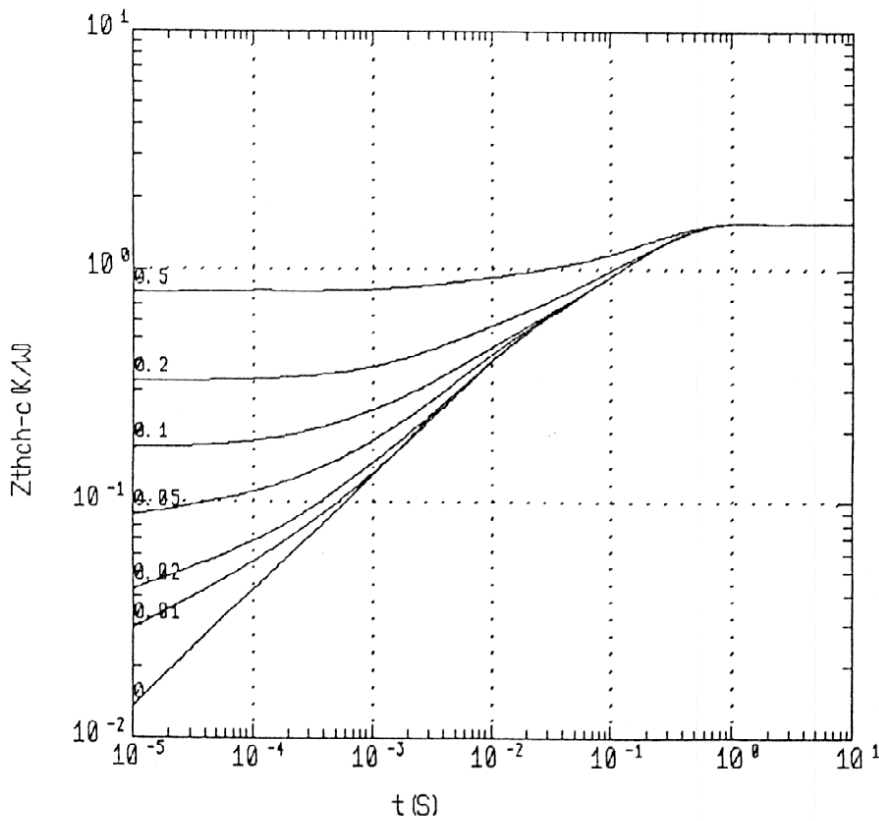

This material and the information herein is the property of Fuji Electric Co., Ltd. They shall be neither reproduced, copied, lent, or disclosed in any way whatsoever for the use of any third party, nor used for the manufacturing purposes without the express written consent of Fuji Electric Co., Ltd.

				Fuji Electric Co., Ltd.	
DATE	NAME	APPROVED			
DRAWN	-		DWG. NO.	MT5 F 4259	9/9
CHECKED	-				
REVISIONS					

FUJI POWER MOS FET

TYPE : 2SKI503-01

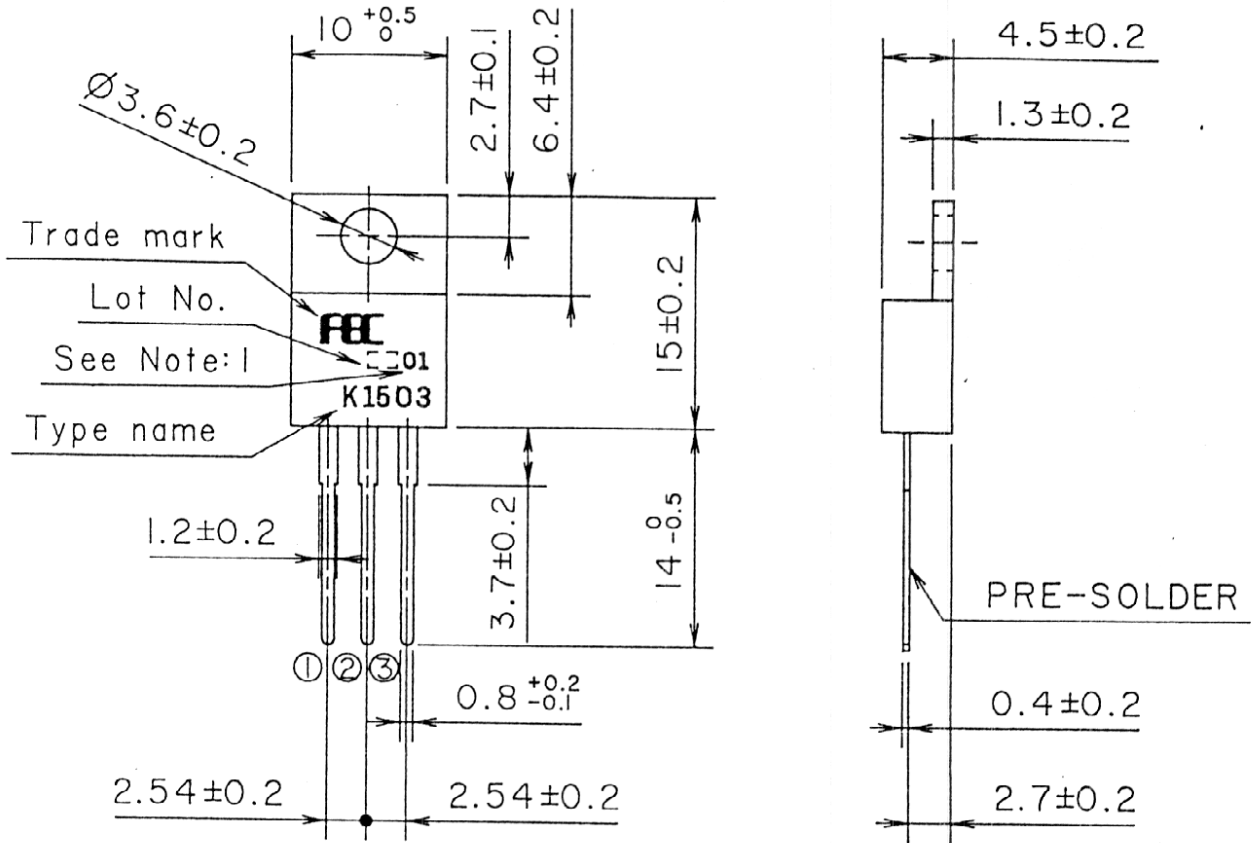

DIMENSIONS ARE IN MILLIMETERS.

CONNECTION

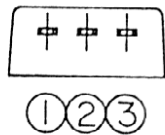

- ① GATE
- ② DRAIN
- ③ SOURCE

JEDEC : TO-220AB

Note 1. Guaranteed mark of avalanche ruggedness.

DATE	NAME	APPROVED	Fuji Electric Co.,Ltd.	
DRAWN 1992-02-21	HIRAGURI	M.	MS.T0220. 2SKI503-01E	
CHECKED 1992-02-21	MARUYAMA	Miyagi		
REVISIONS			DWG.NO.	MK5C27595

This material and the information herein is the property of Fuji Electric Co., Ltd. They shall be neither reproduced, copied, lent, or disclosed in any way whatsoever for the use of any third party, nor used for the manufacturing purposes without the express written consent of Fuji Electric Co., Ltd.