

MOS Field Effect Transistor 2SK3299

■ Features

- Low gate charge
Q_G = 34 nC TYP. (V_{DD} = 450 V, V_{GS} = 10 V, I_D = 10 A)
- Gate voltage rating ±30 V
- Low on-state resistance
R_{DS(on)} = 0.75 Ω MAX. (V_{GS} = 10 V, I_D = 5.0 A)
- Avalanche capability ratings
- Surface mount package available

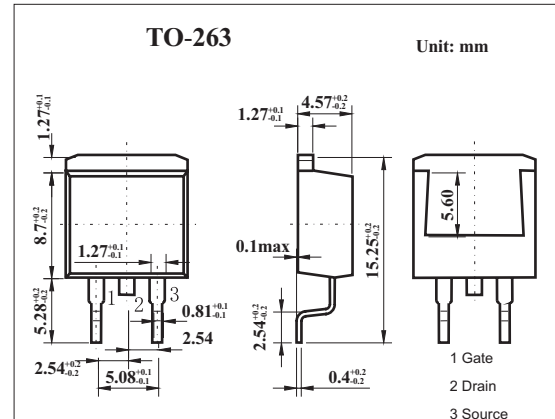

■ Absolute Maximum Ratings Ta = 25°C

Parameter	Symbol	Rating	Unit
Drain to source voltage	V _{DSS}	600	V
Gate to source voltage	V _{GSS}	±30	V
Drain current	I _D	±10	A
	I _{DP} *	±40	A
Power dissipation	P _D	T _A =25°C	1.5
		T _C =25°C	75
Channel temperature	T _{ch}	150	°C
Storage temperature	T _{stg}	-55 to +150	°C

* PW ≤ 10 μs, Duty Cycle ≤ 1%

■ Electrical Characteristics Ta = 25°C

Parameter	Symbol	Test conditions	Min	Typ	Max	Unit
Drain cut-off current	I _{DSS}	V _{DS} =600V, V _{GS} =0			100	μA
Gate leakage current	I _{GSS}	V _{GS} = ±30V, V _{DS} =0			±100	μA
Gate cutoff voltage	V _{GS(off)}	V _{DS} =10V, I _D =1mA	2.5		3.5	V
Forward transfer admittance	Y _{fs}	V _{DS} =10V, I _D =5.0A	3.2			S
Drain to source on-state resistance	R _{DS(on)}	V _{GS} =10V, I _D =5.0A		0.68	0.75	Ω
Input capacitance	C _{iss}	V _{DS} =10V, V _{GS} =0, f=1MHz		1580		pF
Output capacitance	C _{oss}			280		pF
Reverse transfer capacitance	C _{rss}			25		pF
Turn-on delay time	t _{on}	I _D =5.0A, V _{GS(on)} =10V, R _G =10Ω, V _{DD} =150V		27		ns
Rise time	t _r			17		ns
Turn-off delay time	t _{off}			66		ns
Fall time	t _f			24		ns