

Super FAP-G Series

N-CHANNEL SILICON POWER MOSFET

■ Outline Drawings [mm]

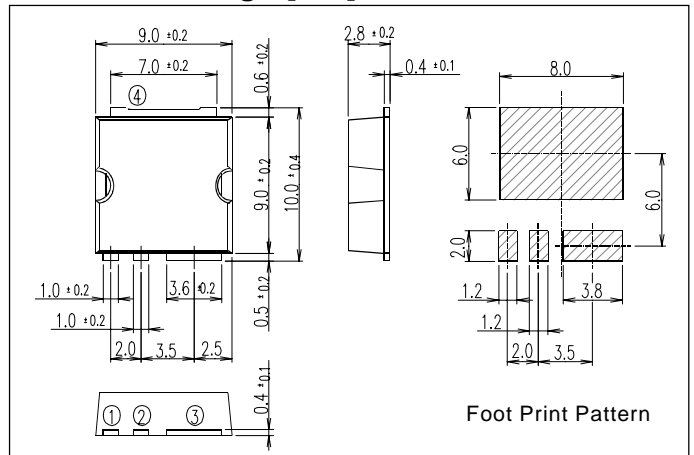

■ Features

- High speed switching
- Low on-resistance
- No secondary breakdown
- Low driving power
- Avalanche-proof

■ Applications for Switching

■ Absolute Maximum Ratings at Tc=25°C (unless otherwise specified)

Item	Symbol	Ratings	Unit	Remarks
Drain-source voltage	V _{DS}	150	V	
	V _{DSX}	120	V	V _{GS} =30V
Continuous drain current	I _D	±33	A	
		±4.1 *4	A	T _a =25°C
Pulsed drain current	I _{D(puls)}	±132	A	
Gate-source voltage	V _{GS}	±30	V	
Repetitive or non-repetitive	I _{AR} *2	33	A	
Maximum Avalanche Energy	E _{AS} *1	169	mJ	
Maximum Drain-Source dV/dt	dV _{DS} /dt	20	kV/μs	V _{DS} ≤ 150V
Peak Diode Recovery dV/dt	dV/dt *3	5	kV/μs	
Max. power dissipation	P _D	2.4 *4	W	T _a =25°C
		150	W	
Operating and storage temperature range	T _{ch}	+150	°C	
	T _{stg}	-55 to +150	°C	

■ Equivalent circuit schematic

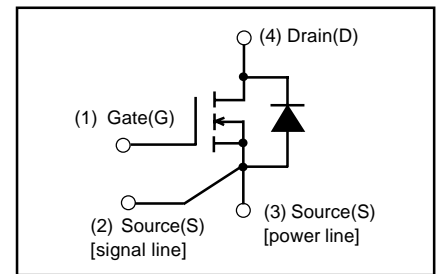

*1 L=0.228mH, V_{CC}=48V, See to Avalanche Energy Graph *2 T_{ch} ≤ 150°C *3 I_F ≤ -I_D, -di/dt=50A/μs, V_{CC} ≤ BV_{DSS}, T_{ch} ≤ 150°C
*4 Surface mounted on 1000mm², t=1.6mm FR-4 PCB(Drain pad area:500mm²)

● Electrical characteristics at Tc = 25°C (unless otherwise specified)

Item	Symbol	Test Conditions	Min.	Typ.	Max.	Units
Drain-source breakdown voltage	V _{(BR)DSS}	I _D =250μA V _{GS} =0V	150			V
Gate threshold voltage	V _{GS(th)}	I _D = 250μA V _{DS} =V _{GS}	3.0		5.0	V
Zero gate voltage drain current	I _{DSS}	V _{DS} =150V V _{GS} =0V			25	μA
		V _{DS} =120V V _{GS} =0V			250	
Gate-source leakage current	I _{GSS}	V _{GS} =±30V V _{DS} =0V		10	100	nA
Drain-source on-state resistance	R _{DS(on)}	I _D =11.5A V _{GS} =10V		54	70	mΩ
Forward transconductance	g _{fs}	I _D =11.5A V _{DS} =25V	8	16		S
Input capacitance	C _{iss}	V _{DS} =75V		1500	1730	pF
Output capacitance	C _{oss}	V _{GS} =0V		200	300	
Reverse transfer capacitance	C _{rss}	f=1MHz		17	26	
Turn-on time t _{on}	t _{d(on)}	V _{CC} =48V I _D =11.5A		13	20	ns
	t _r	V _{GS} =10V		15	23	
Turn-off time t _{off}	t _{d(off)}	R _{GS} =10Ω		34	51	
	t _f			15	23	
Total Gate Charge	Q _G	V _{CC} =48V		34	51	nC
Gate-Source Charge	Q _{GS}	I _D =23A		9	13.5	
Gate-Drain Charge	Q _{GD}	V _{GS} =10V		12.5	19	
Avalanche capability	I _{AV}	L=228μH T _{ch} =25°C	33			A
Diode forward on-voltage	V _{SD}	I _F =23A V _{GS} =0V T _{ch} =25°C		1.10	1.60	V
Reverse recovery time	t _{rr}	I _F =23A V _{GS} =0V		0.13		μs
Reverse recovery charge	Q _{rr}	-di/dt=100A/μs T _{ch} =25°C		0.6		μC

● Thermal characteristics

Item	Symbol	Test Conditions	Min.	Typ.	Max.	Units
Thermal resistance	R _{th(ch-c)}	channel to case			0.833	°C/W
	R _{th(ch-a)}	channel to ambient			87.0	°C/W
	R _{th(ch-a)} *4	channel to ambient			52.0	°C/W

Characteristics

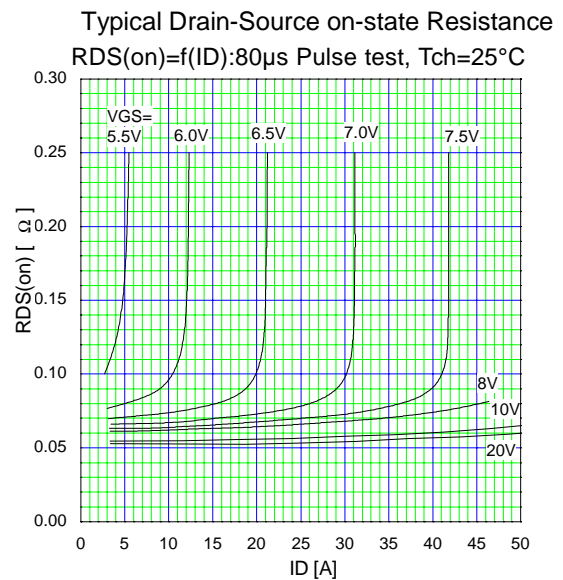
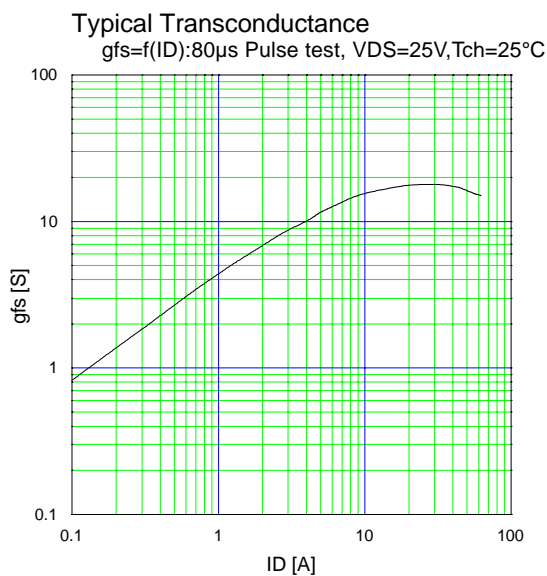
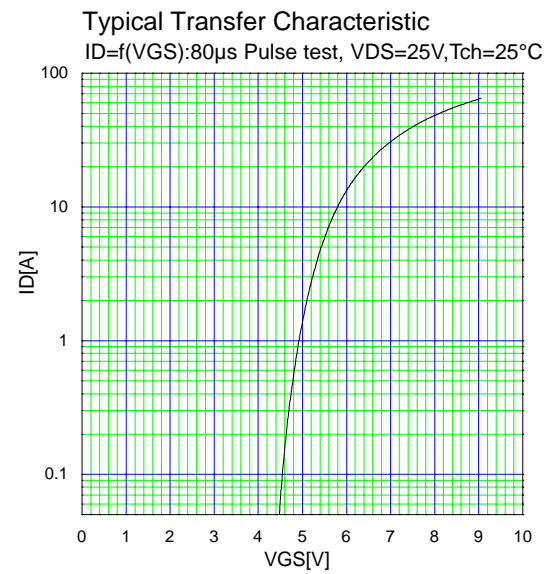
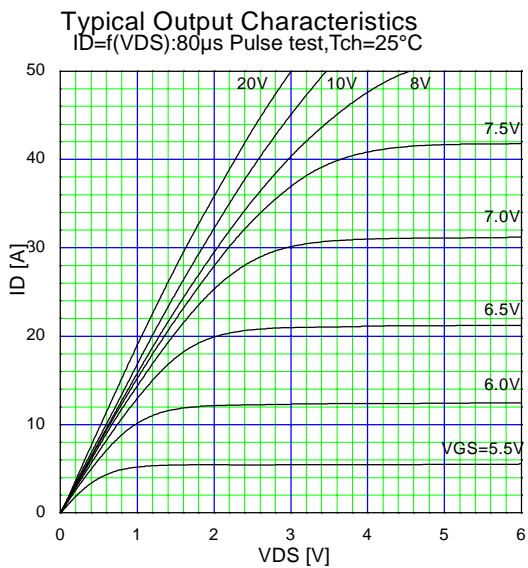
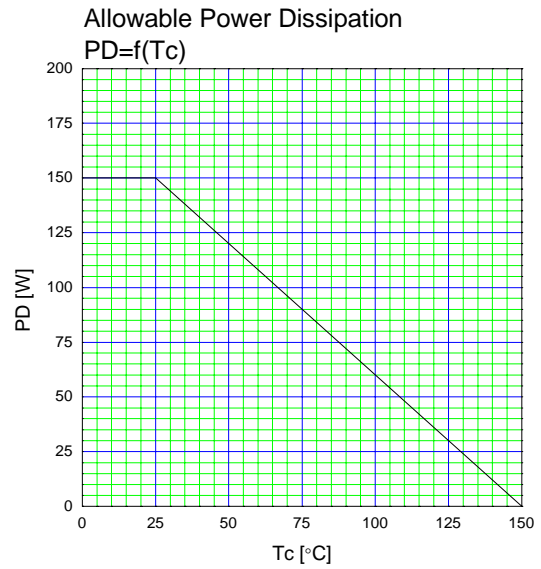
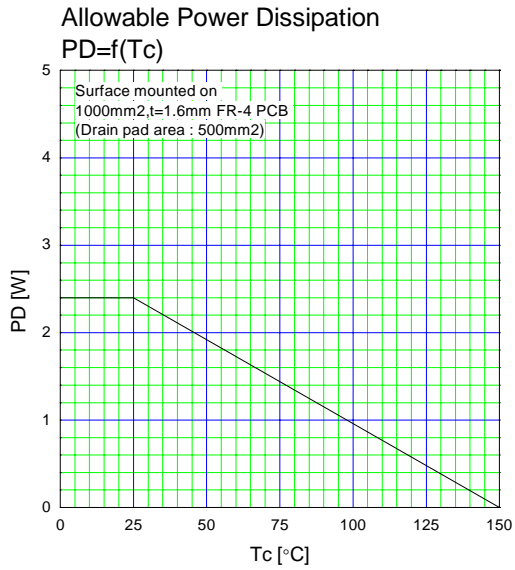

Drain-Source On-state Resistance
 $R_{DS(on)}=f(T_{ch}):I_D=11.5A, V_{GS}=10V$

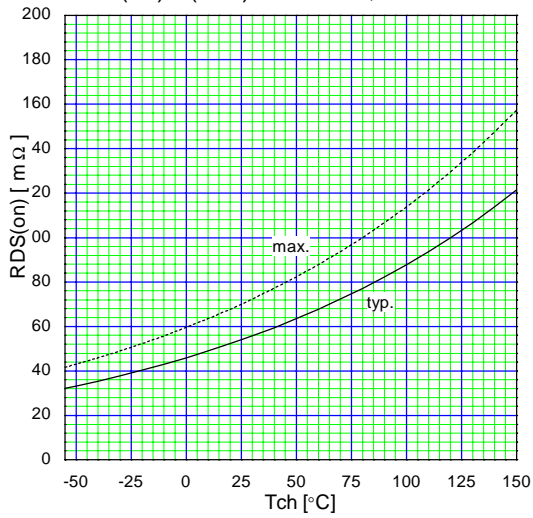

Gate Threshold Voltage vs. T_{ch}
 $V_{GS(th)}=f(T_{ch}):V_{DS}=V_{GS}, I_D=1mA$

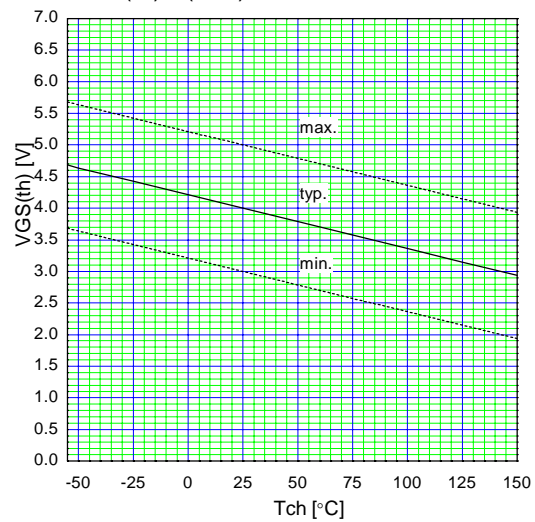

Typical Gate Charge Characteristics
 $V_{GS}=f(Q_g):I_D=23A, T_{ch}=25°C$

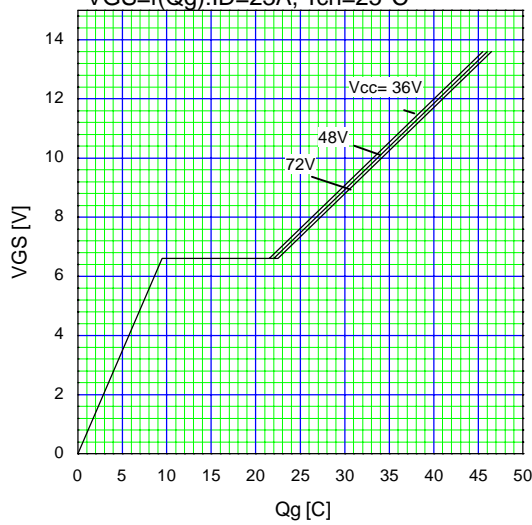

Typical Capacitance
 $C=f(V_{DS}):V_{GS}=0V, f=1MHz$

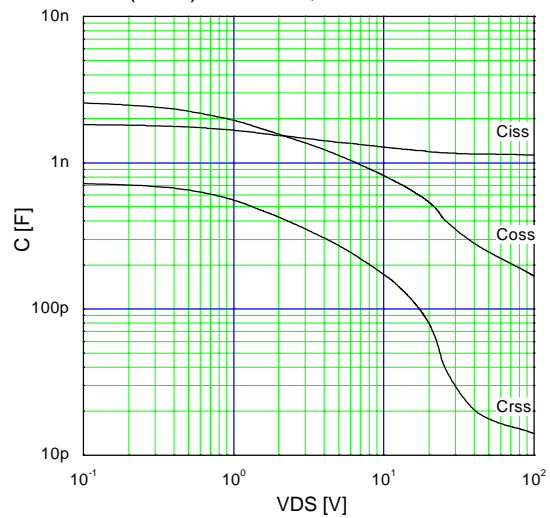

Typical Forward Characteristics of Reverse Diode
 $I_F=f(V_{SD}):80\mu s \text{ Pulse test}, T_{ch}=25°C$

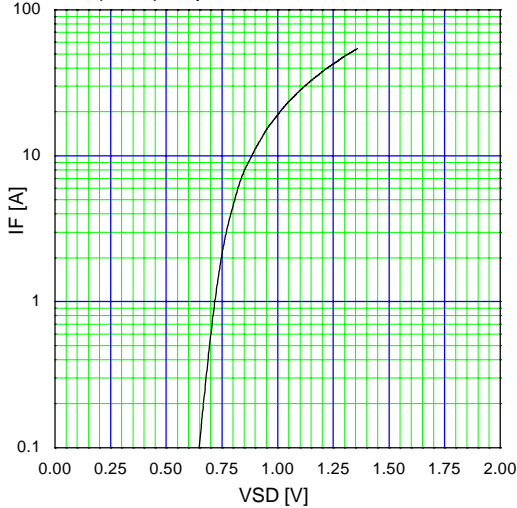

Typical Switching Characteristics vs. I_D
 $t=f(I_D):V_{cc}=48V, V_{GS}=10V, R_G=10\Omega$

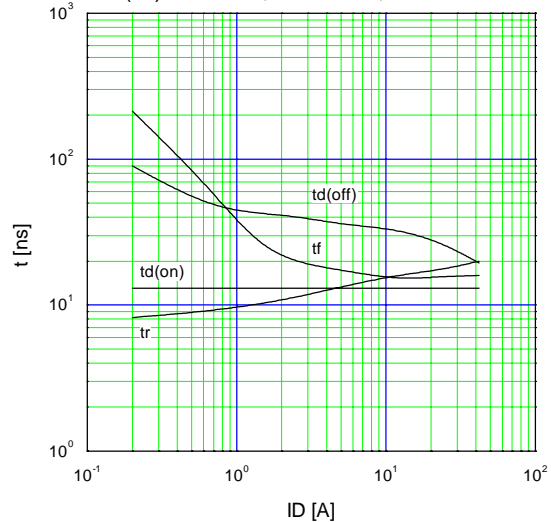

Maximum Avalanche Energy vs. starting Tch
 $E_{AS}=f(\text{starting Tch}):V_{CC}=48V$

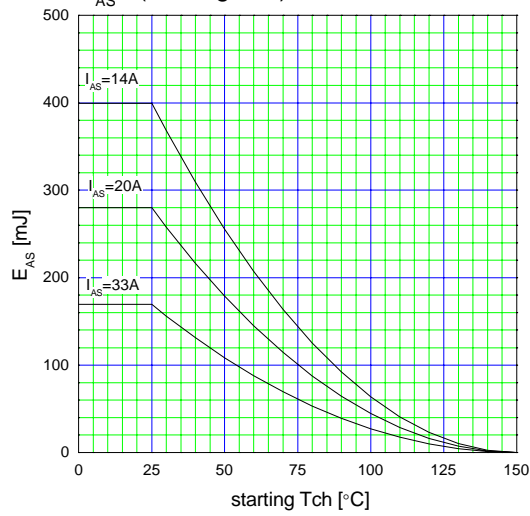

Thermal Resistance vs. Drain Pad area
 $t=1.6mm$ FR-4 PCB

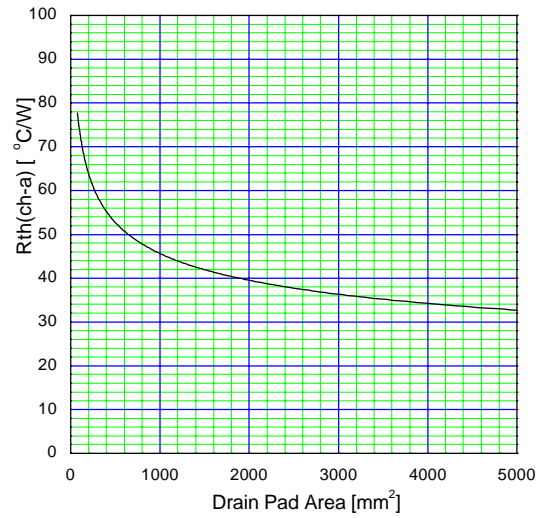

Maximum Transient Thermal Impedance
 $Z_{th}(ch-c)=f(t):D=0$

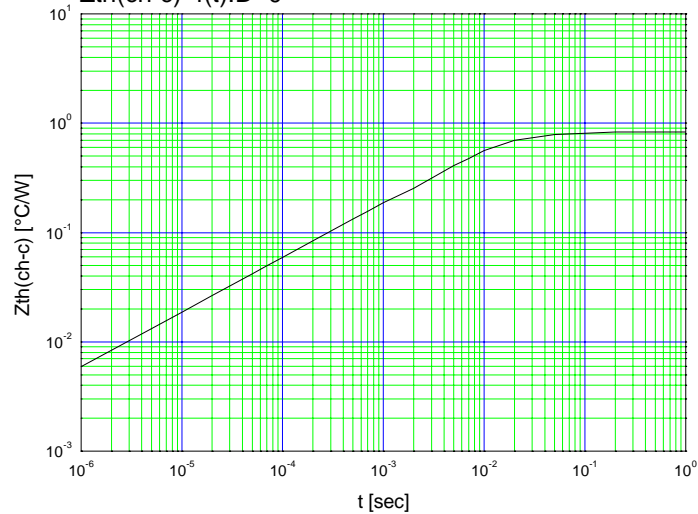

Maximum Avalanche Current Pulsewidth
 $I_{AV}=f(t_{AV}):starting Tch=25°C, V_{CC}=48V$

