

2SK3647-01

FUJI POWER MOSFET Super FAP-G Series

N-CHANNEL SILICON POWER MOSFET

■ Outline Drawings (mm)

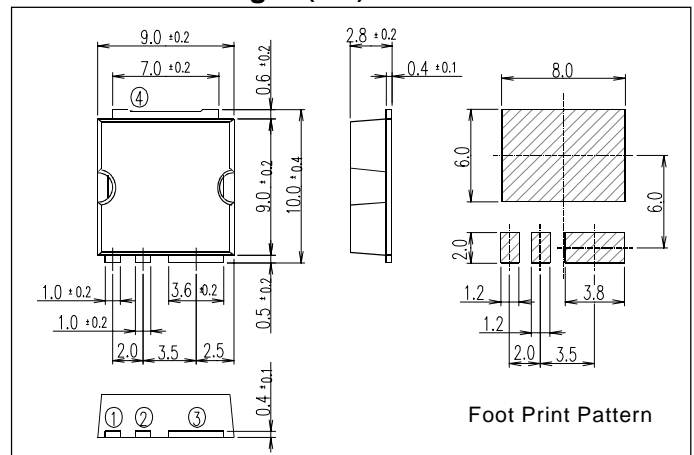

■ Features

- High speed switching
- Low on-resistance
- No secondary breakdown
- Low driving power
- Avalanche-proof

■ Applications

- Switching regulators
- UPS (Uninterruptible Power Supply)
- DC-DC converters

■ Maximum ratings and characteristic

Absolute maximum ratings

($T_c=25^\circ\text{C}$ unless otherwise specified)

Item	Symbol	Ratings	Unit	
Drain-source voltage	V_{DS}	100	V	
	V_{DSX}^*5	70	V	
Continuous drain current	I_D	$T_c=25^\circ\text{C}$	± 41	A
		$T_a=25^\circ\text{C}$	$\pm 5.2^{**}$	A
Pulsed drain current	$I_{D(puls)}$	± 164	A	
Gate-source voltage	V_{GS}	± 30	V	
Non-repetitive Avalanche current	I_{AS}^*2	41	A	
Maximum Avalanche Energy	E_{AS}^*1	204.7	mJ	
Maximum Drain-Source dV/dt	dV_{DS}/dt^*4	20	kV/ μs	
Peak Diode Recovery dV/dt	dV/dt^*3	5	kV/ μs	
Max. power dissipation	P_D	$T_c=25^\circ\text{C}$	150	W
		$T_a=25^\circ\text{C}$	2.4 ^{**}	W
Operating and storage temperature range	T_{ch}	+150	$^\circ\text{C}$	
	T_{stg}	-55 to +150	$^\circ\text{C}$	

** Surface mounted on 1000mm², t=1.6mm FR-4 PCB(Drain pad area : 500mm²)

*1 L=146 μH , $V_{CC}=48\text{V}$, $T_{ch}=25^\circ\text{C}$, See to Avalanche Energy Graph *2 $T_{ch} \leq 150^\circ\text{C}$

*3 $I_F \leq -I_D$, $-di/dt=50\text{A}/\mu\text{s}$, $V_{CC} \leq BV_{DSS}$, $T_{ch} \leq 150^\circ\text{C}$ *4 $V_{DS} \leq 100\text{V}$ *5 $V_{GS}=-30\text{V}$ *6 t=60sec f=60Hz

■ Equivalent circuit schematic

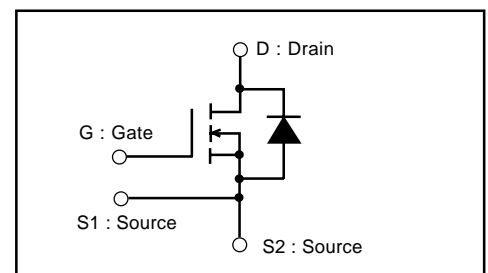

● Electrical characteristics ($T_c=25^\circ\text{C}$ unless otherwise specified)

Item	Symbol	Test Conditions	Min.	Typ.	Max.	Units
Drain-source breakdown voltage	$V_{(BR)DSS}$	$I_D=250\mu\text{A}$ $V_{GS}=0\text{V}$	100			V
Gate threshold voltage	$V_{GS(th)}$	$I_D=250\mu\text{A}$ $V_{DS}=V_{GS}$	3.0		5.0	V
Zero gate voltage drain current	I_{DSS}	$V_{DS}=100\text{V}$ $V_{GS}=0\text{V}$			25	μA
		$V_{DS}=80\text{V}$ $V_{GS}=0\text{V}$			250	μA
Gate-source leakage current	I_{GSS}	$V_{GS}=\pm 30\text{V}$ $V_{DS}=0\text{V}$		10	100	nA
Drain-source on-state resistance	$R_{DS(on)}$	$I_D=15\text{A}$ $V_{GS}=10\text{V}$		34	44	m Ω
Forward transconductance	g_{fs}	$I_D=15\text{A}$ $V_{DS}=25\text{V}$	9	18		S
Input capacitance	C_{iss}	$V_{DS}=75\text{V}$		1110	1665	pF
Output capacitance	C_{oss}	$V_{GS}=0\text{V}$		280	420	pF
Reverse transfer capacitance	C_{rss}	f=1MHz		22	33	pF
Turn-on time t_{on}	$t_{d(on)}$	$V_{CC}=48\text{V}$ $I_D=15\text{A}$		16	24	ns
	t_r	$V_{GS}=10\text{V}$		23	35	ns
Turn-off time t_{off}	$t_{d(off)}$	$R_{GS}=10\Omega$		31	47	ns
	t_f			16	24	ns
Total Gate Charge	Q_G	$V_{CC}=50\text{V}$		32	48	nC
Gate-Source Charge	Q_{GS}	$I_D=30\text{A}$		13	20	nC
Gate-Drain Charge	Q_{GD}	$V_{GS}=10\text{V}$		9	14	nC
Avalanche capability	I_{AV}	L=146 μH $T_{ch}=25^\circ\text{C}$	41			A
Diode forward on-voltage	V_{SD}	$I_F=30\text{A}$ $V_{GS}=0\text{V}$ $T_{ch}=25^\circ\text{C}$		1.10	1.65	V
Reverse recovery time	t_{rr}	$I_F=30\text{A}$ $V_{GS}=0\text{V}$		0.1		μs
Reverse recovery charge	Q_{rr}	$-di/dt=100\text{A}/\mu\text{s}$ $T_{ch}=25^\circ\text{C}$		0.38		μC

● Thermal characteristics

Item	Symbol	Test Conditions	Min.	Typ.	Max.	Units
Thermal resistance	$R_{th(ch-c)}$	channel to case			0.833	$^\circ\text{C}/\text{W}$
	$R_{th(ch-a)}$	channel to ambient			87.0	$^\circ\text{C}/\text{W}$
	$R_{th(ch-a)}^{**}$	channel to ambient			52.0	$^\circ\text{C}/\text{W}$

** Surface mounted on 1000mm², t=1.6mm FR-4 PCB(Drain pad area : 500mm²)

Characteristics

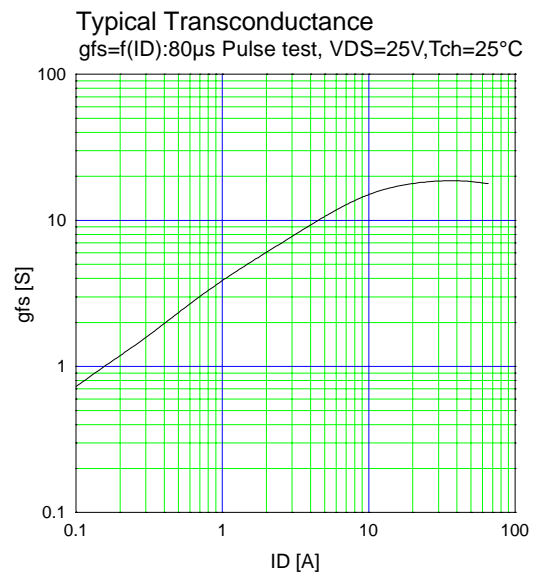
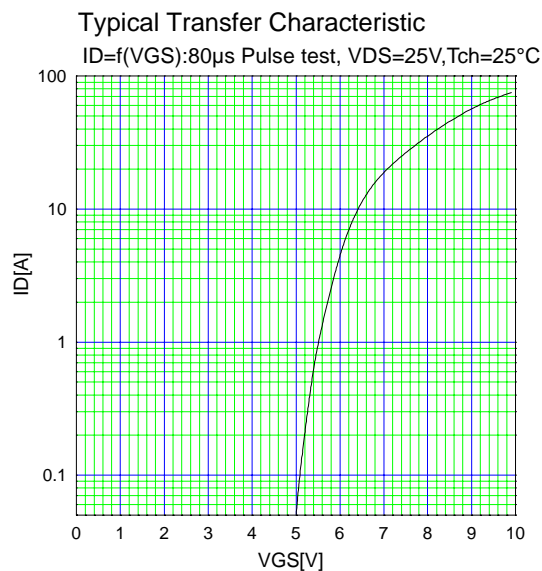
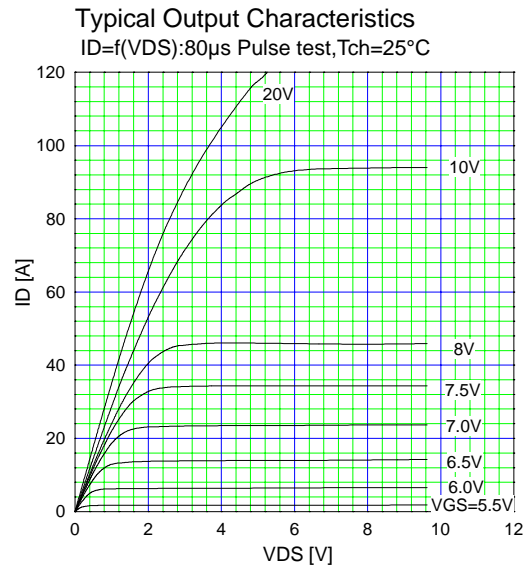
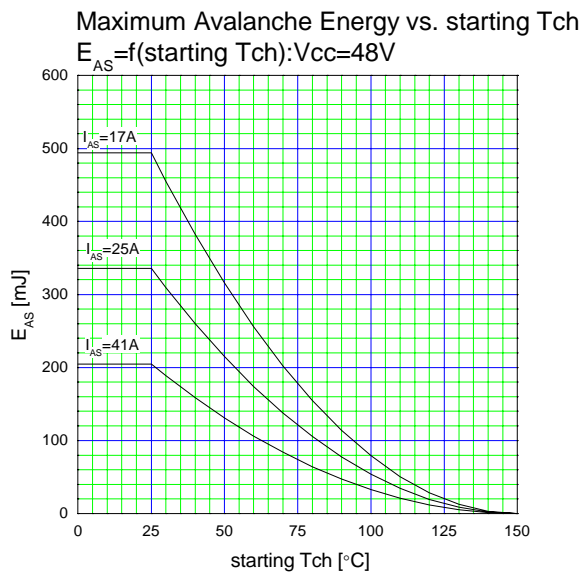
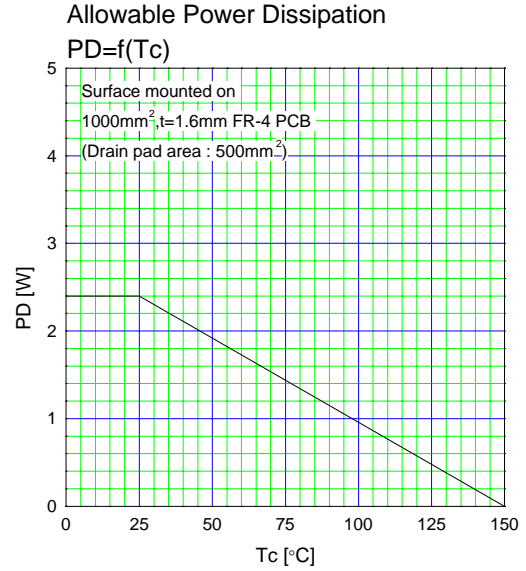
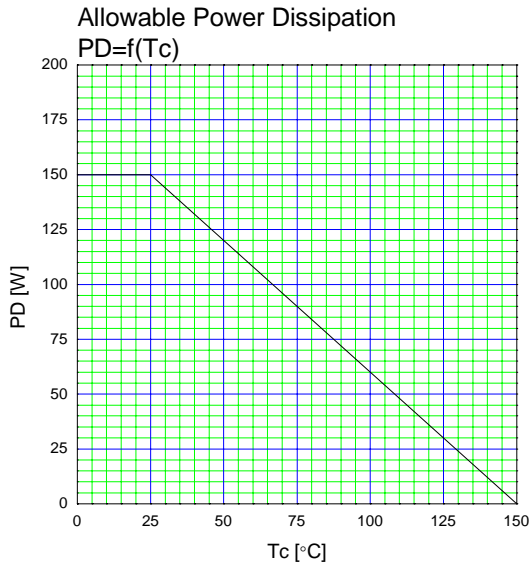

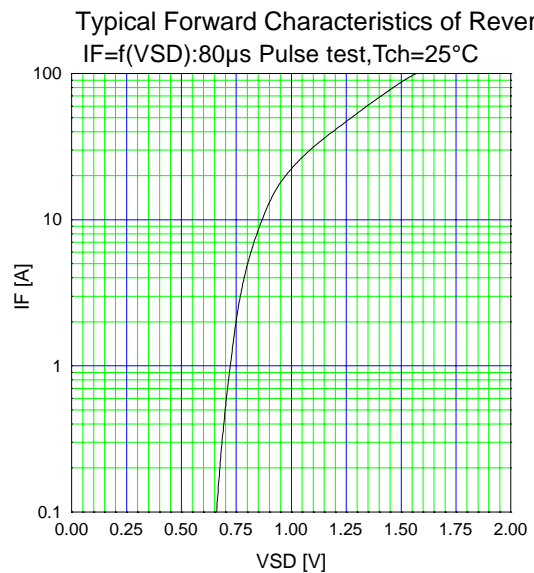
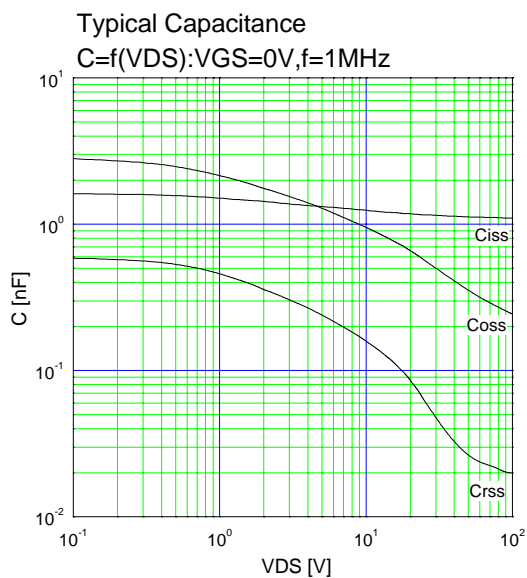
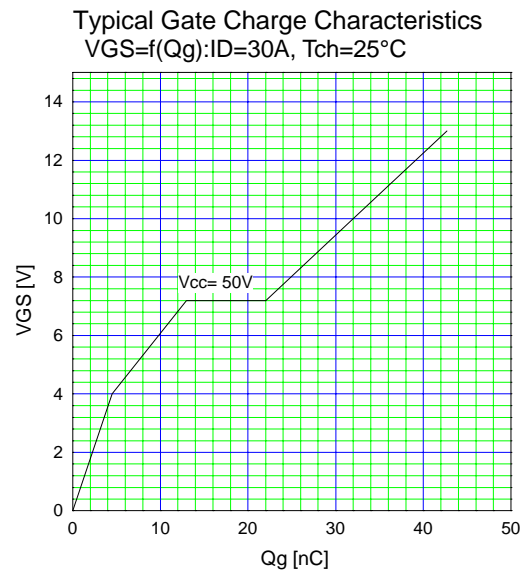
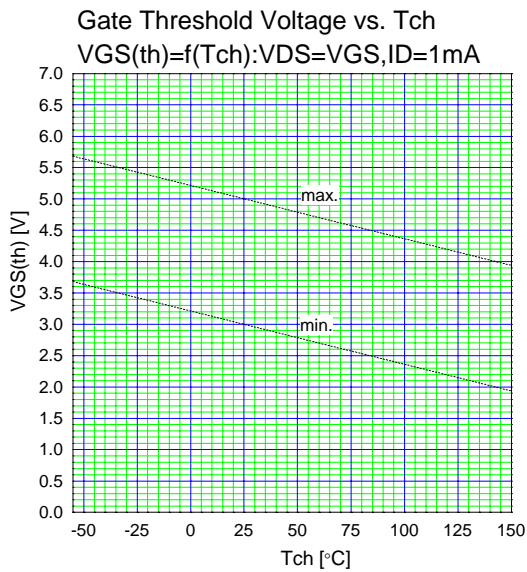
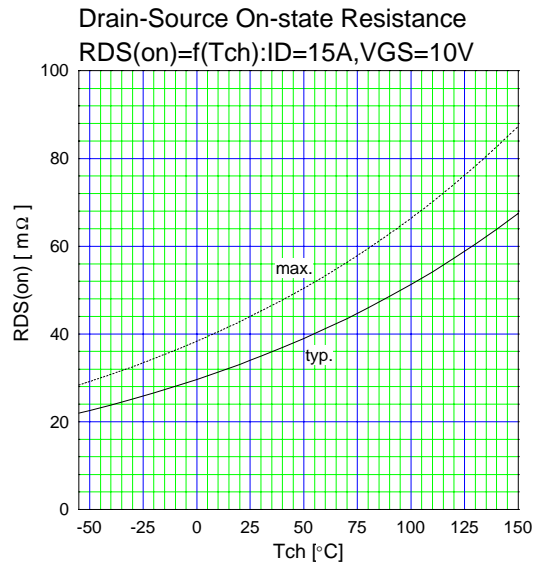
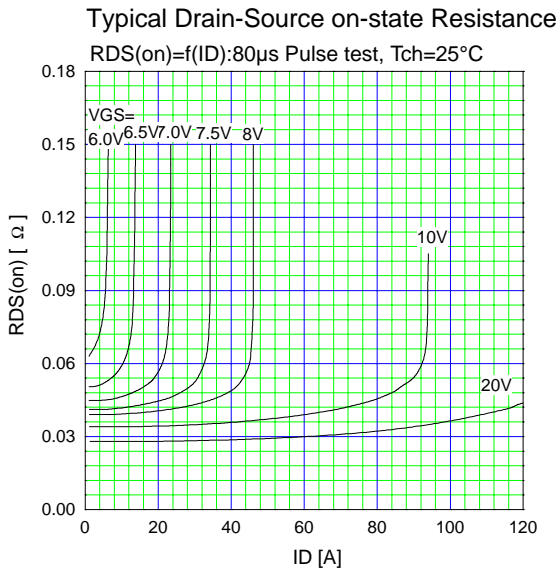

Typical Switching Characteristics vs. ID
 $t=f(I_D): V_{CC}=48V, V_{GS}=10V, R_G=10\Omega$

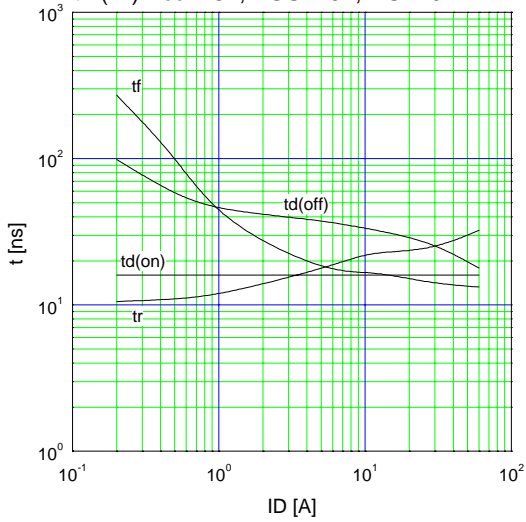

Thermal Resistance vs. Drain Pad area
 $t=1.6mm$ FR-4 PCB

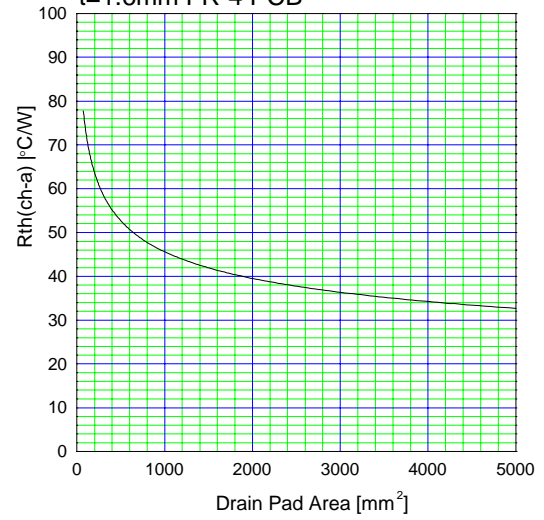

Maximum Avalanche Current Pulsewidth
 $I_{AV}=f(t_{AV}):$ starting $T_{ch}=25^\circ C, V_{CC}=48V$

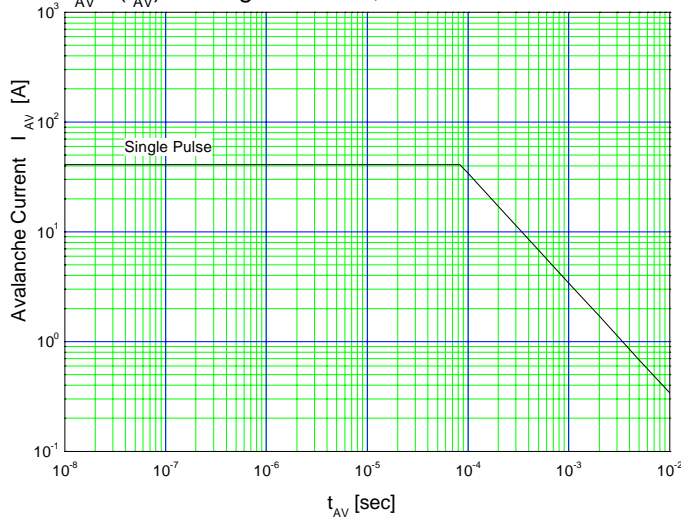

Maximum Transient Thermal Impedance
 $Z_{th}(ch-c)=f(t): D=0$

