

2SK3674-01L,S,SJ (900V/2.0Ω/7A)

1) Package T-PACK L ··· See Page 2/4
S ··· See Page 3/4
SJ ··· See Page 4/4

2) Absolute Maximum Ratings (Tc=25 unless otherwise specified)

Items	Symbols	Ratings	Units
Drain-Source Voltage	V_{DS}	900	V
Continuous Drain Current	I_D	±7	A
Pulsed Drain Current	$I_{D(pulse)}$	±28	A
Gate-Source Voltage	V_{GS}	±30	V
Repetitive and Non-Repetitive Maximum Avalanche Current	I_{AR}	7	A
Non-Repetitive Maximum Avalanche Energy	E_{AS}	269.5	mJ *1
Maximum Drain-Source dV/dt	dV/dt	20	kV/us
Peak Diode recovery dV/dt	dV/dt	5	kV/us *2
Maximum Power Dissipation	$P_D @ T_c=25$	225	W
	$P_D @ T_a=25$	1.67	W
Operating and Storage Temperature range	T_{ch} T_{stg}	150 -55 ~ +150	

3) Electrical Characteristics (Tch=25 unless otherwise specified)

Items	Symbols	Test Conditions	min.	typ.	max.	Units
Drain-Source Breakdown Voltage	BV_{DSS}	$I_D=250\mu A$ $V_{GS}=0V$	900	---	---	V
Gate Threshold Voltage	$V_{GS(th)}$	$I_D=250\mu A$ $V_{DS}=V_{GS}$	3.0	---	5.0	V
Zero Gate Voltage Drain Current	I_{DSS}	$V_{DS}=900V$ $T_{ch}=25$	---	---	50	μA
		$V_{GS}=0V$ $T_{ch}=125$	---	---	500	μA
Gate-Source Leakage Current	I_{GSS}	$V_{GS}=\pm 30V$ $V_{DS}=0V$	---	---	100	nA
Drain-Source On-State Resistance	$R_{DS(on)}$	$I_D=3.5A$ $V_{GS}=10V$	---	---	2.0	Ω
Input Capacitance	C_{iss}	$V_{DS}=25V$	---	980	---	pF
Output Capacitance	C_{oss}	$V_{GS}=0V$	---	120	---	
Reverse Transfer Capacitance	C_{rss}	$f=1MHz$	---	6	---	nC
Total Gate Charge	Q_g	$V_{CC}=450V$	---	28	---	
Gate to Source Charge	Q_{gs}	$I_D=7A$	---	9	---	
Gate to Drain (Miller) Charge	Q_{gd}	$V_{GS}=10V$	---	8	---	
Avalanche Capability	I_{AV}	$L=10.1mH$ $T_{ch}=25$	7	---	---	A
Diode Forward On-Voltage	V_{SD}	$I_F=7A, V_{GS}=0V, T_{ch}=25$	---	1.0	1.5	V

4) Thermal Characteristics

Items	Symbols	Test Conditions	min.	typ.	max.	Units
Channel to Case	$R_{th(ch-c)}$				0.56	/W
Channel to Ambient	$R_{th(ch-a)}$				75.0	/W

*1 L=10.1mH, Vcc=90V

*2 $I_F \leq -I_D, -di/dt=50A/\mu s, V_{CC} \leq BV_{DSS}, T_{ch} \leq 150^\circ C$

DATE	NAME	APPROVED	Fuji Electric Co.,Ltd.		
DRAWN Sep. -10-'02	T. Kuboyama	T. HOSEN	DWG. NO.	MT5F12615	1/4
CHECKED Sep. -10-'02	T. Yamada				

This material and the information herein is the property of Fuji Electric Co., Ltd. They shall be neither reproduced, copied, lent, or disclosed in any way whatsoever for the use of any third party nor used for the manufacturing purposes without the express written consent of Fuji Electric Co., Ltd.

REVISIONS

MA4LE

FUJI POWER MOS FET

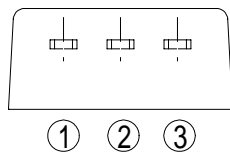
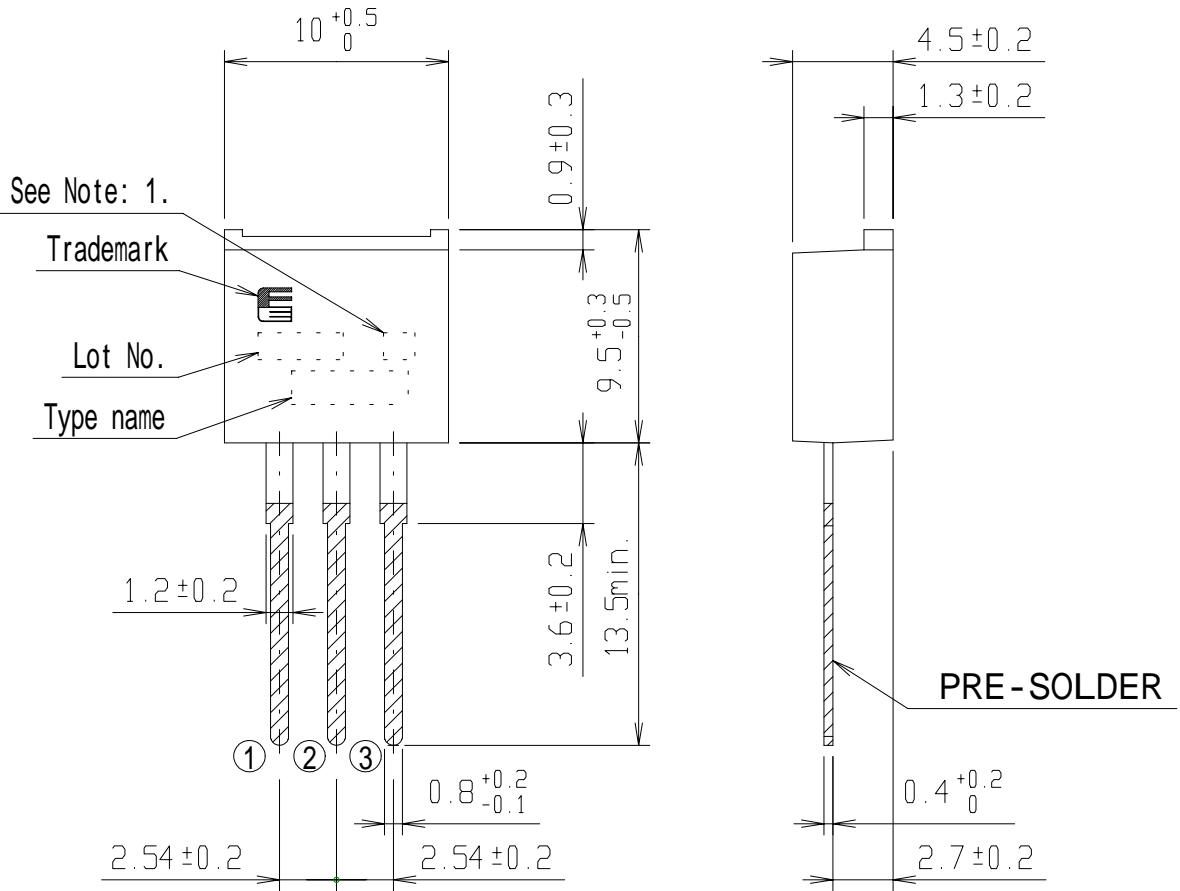

CONNECTION

- ① GATE
- ② DRAIN
- ③ SOURCE

JEDEC : TO-220AB

Note: 1. Guaranteed mark of avalanche ruggedness.

DIMENSIONS ARE IN MILLIMETERS.

This material and the information herein is the property of Fuji Electric Co.,Ltd. They shall be neither reproduced, copied, lent, or disclosed in any way whatsoever for the use of any third party nor used for the manufacturing purposes without the express written consent of Fuji Electric Co.,Ltd.

	DATE	NAME	APPROVED	Fuji Electric Co.,Ltd.
DRAWN				MT5F12615 2/4
CHECKED				
REVISIONS				DWG. NO. www.DataSheet4U.com

MA4LE

FUJI POWER MOS FET

OUT VIEW

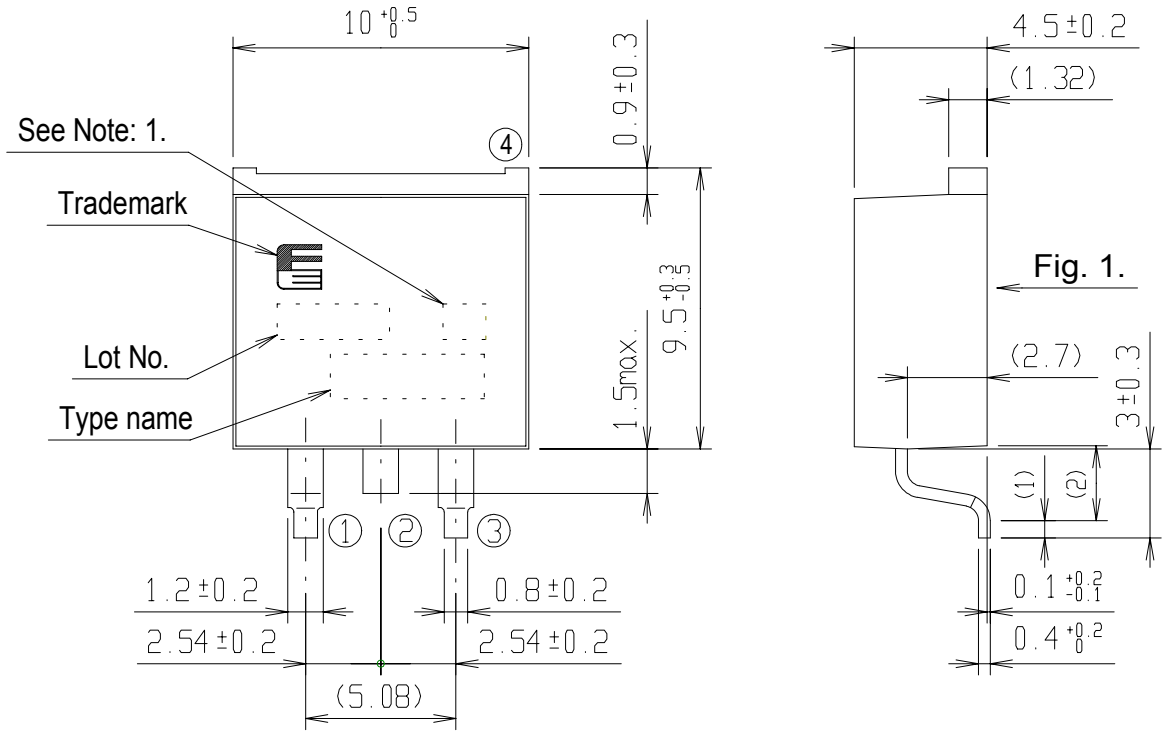
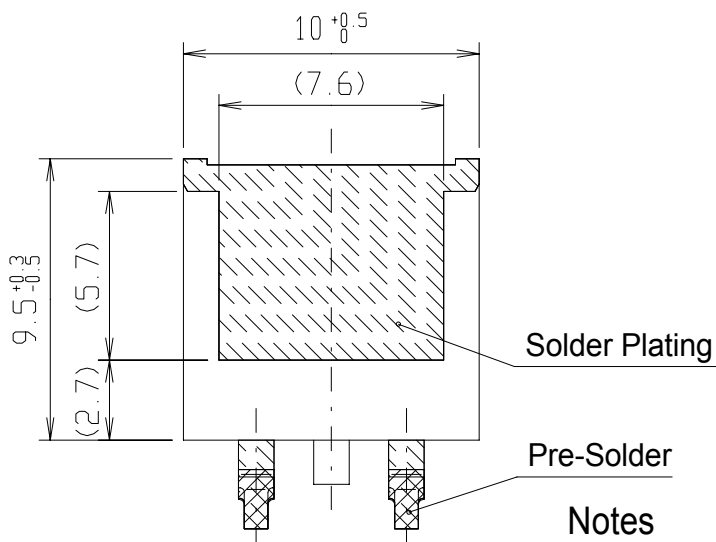

Fig. 1.



CONNECTION

- ① GATE
- ④ ② DRAIN
- ③ SOURCE

Notes

Note: 1. Guaranteed mark of avalanche ruggedness.

1. () : Reference dimensions.
2. The metal part is covered with the solder plating, part of cutting is without the solder plating.

DIMENSIONS ARE IN MILLIMETERS.

This material and the information herein is the property of Fuji Electric Co.,Ltd. They shall be neither reproduced, copied, lent, or disclosed in any way whatsoever for the use of any third party nor used for the manufacturing purposes without the express written consent of Fuji Electric Co.,Ltd.

	DATE	NAME	APPROVED	Fuji Electric Co.,Ltd.
DRAWN				MT5F12615 3/4
CHECKED				
REVISIONS				DWG. NO. MT5F12615 3/4

FUJI POWER MOS FET

OUT VIEW

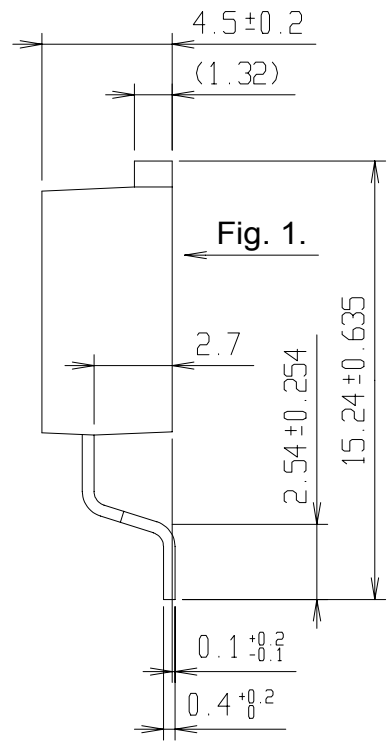
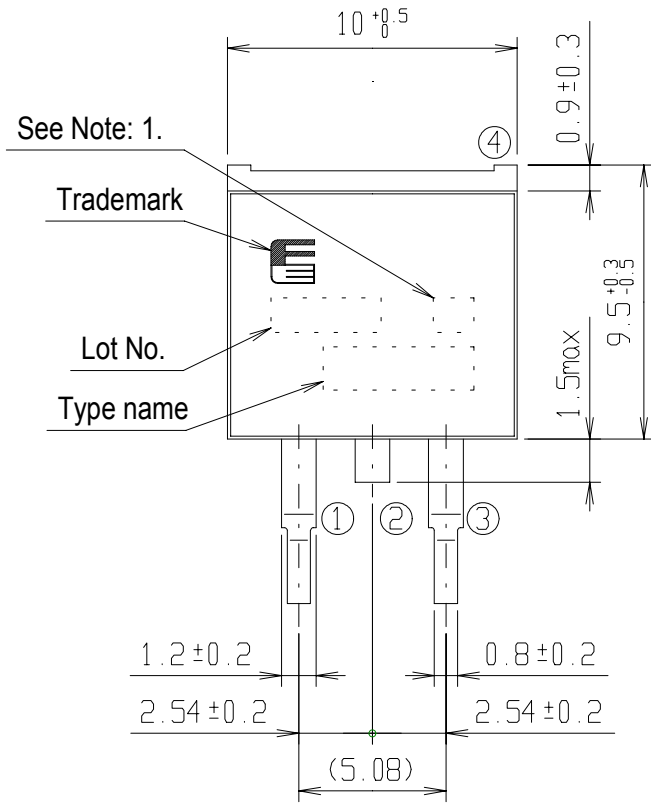
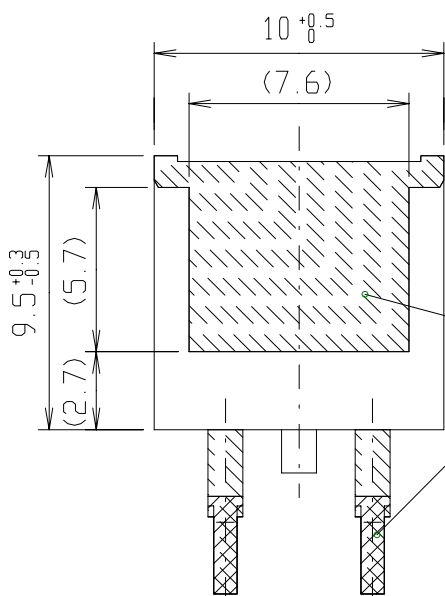

Fig. 1.



CONNECTION

- ① GATE
- ④ ② DRAIN
- ③ SOURCE

Notes

1. () : Reference dimensions.
2. The metal part is covered with the solder plating, part of cutting is without the solder plating.

Note: 1. Guaranteed mark of avalanche ruggedness.

DIMENSIONS ARE IN MILLIMETERS.

This material and the information herein is the property of Fuji Electric Co., Ltd. They shall be neither reproduced, copied, lent, or disclosed in any way whatsoever for the use of any third party nor used for the manufacturing purposes without the express written consent of Fuji Electric Co., Ltd.

	DATE	NAME	APPROVED	Fuji Electric Co., Ltd.
DRAWN				MT5F12615 4/4
CHECKED				
REVISIONS				DWG. NO. MT5F12615 4/4