

T-29-25



2037

N-Channel Junction Silicon Field-Effect Transistor

Capacitor Microphone Impedance Conversion Applications

©1432A

Features

- Especially suited for use in audio, telephone capacitor microphones.
- High yfs.
- Excellent voltage characteristic.
- Adoption of FBET process.

Absolute Maximum Ratings at Ta=25°C

			unit
Gate-Drain Voltage	V _{GDO}	-20	V
Gate Current	I _G	10	mA
Allowable Power Dissipation	P _D	100	mW
Junction Temperature	T _J	125	°C
Storage Temperature	T _{stg}	-55 to +125	°C

Electrical Characteristics at Ta=25°C

		min	typ	max	unit
Drain Current	I _{DSS} V _{DS} =5V, V _{GS} =0	60*		800*	uA

* The 2SK376 is classified by drain current I_{DSS} as follows (unit:uA):

60 J	180	150 K	300	250 L	500	400 M	800
------	-----	-------	-----	-------	-----	-------	-----

[Ta=25°C, V_{CC}=4.5V, R_L=1kohm, c_{in}=15pF, Specified Test Circuit]

		min	typ	max	unit
Transmission Loss	G _v f=1kHz, V _{in} =100mV		-3.5		dB
Reduced Voltage Characteristic	ΔG _{VV} f=1kHz, V _{in} =100mV V _{CC} =4.5 to 1.5V			-3	dB
Frequency Response	ΔG _{Vf} f=1kHz to 110Hz, V _{in} =100mV			-1	dB
Input Impedance	Z _{in} f=1kHz		18.0		Mohm
Output Impedance	Z _o f=1kHz			1.0	kohm
Total Harmonic Distortion	THD f=1kHz, V _{in} =100mV		3		%
Output Noise Voltage	V _{NO} V _{in} =0, A curve			-110	dB

Specified Test Circuit

- Transmission loss
- Frequency response
- Distortion
- Reduced voltage characteristic

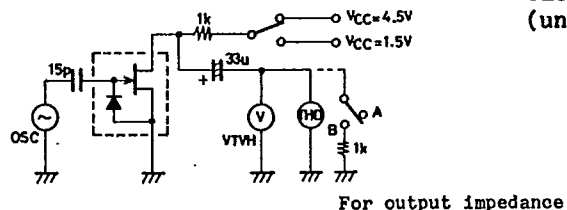

For output impedance

Case Outline 2037 (unit:mm)

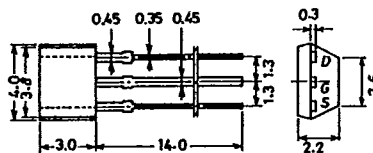

D: Drain
G: Gate
S: Source
SANYO: SP'

2SK376

T-29-25

查询"2SK376"供应商

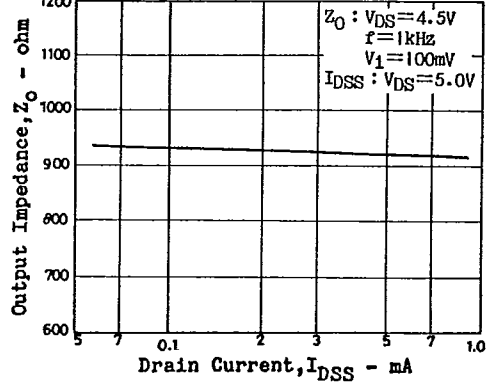
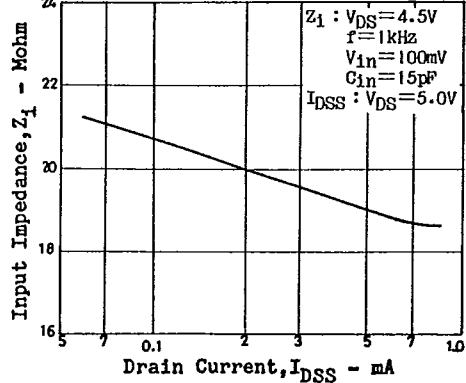
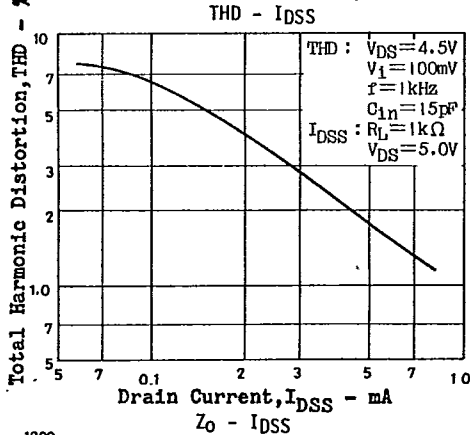
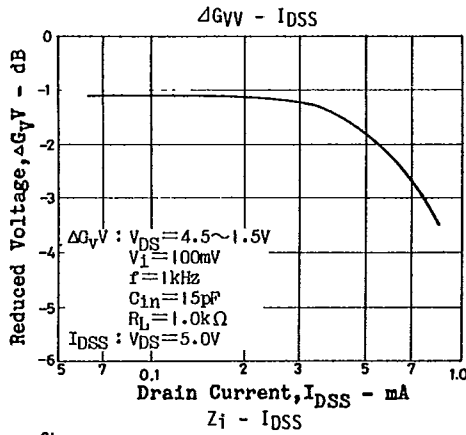
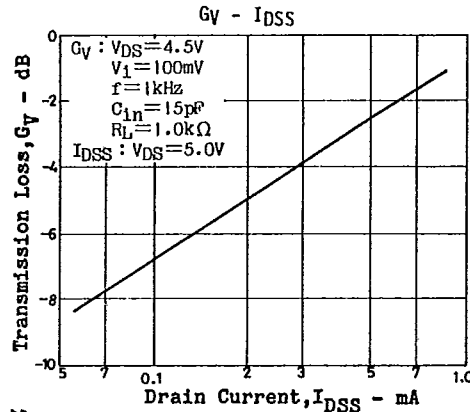
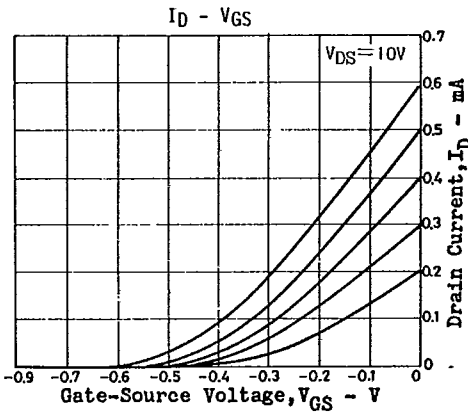
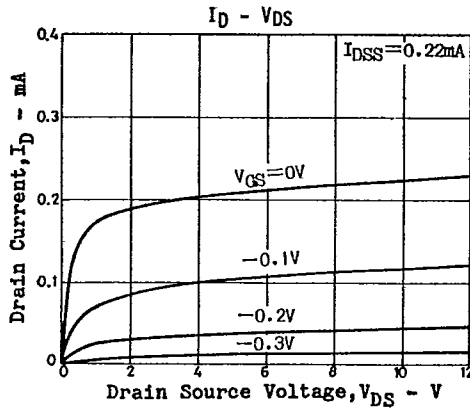
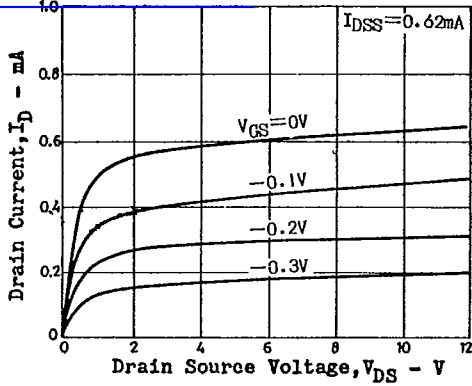

2SK376

T-29-25

查询"2SK376"供应商

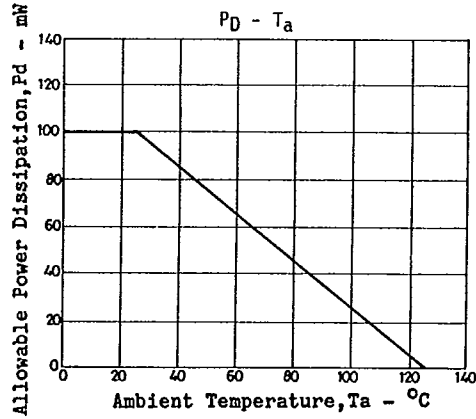
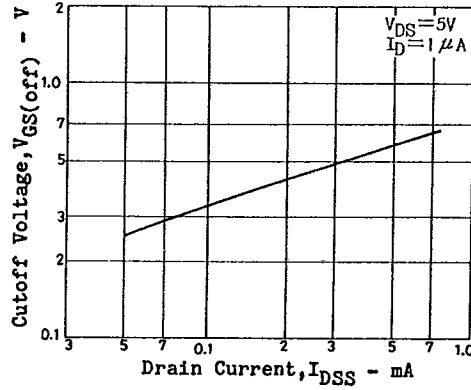
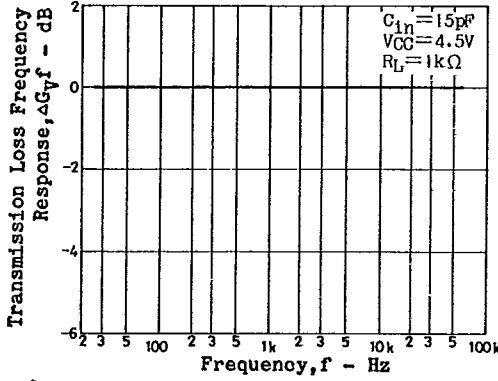
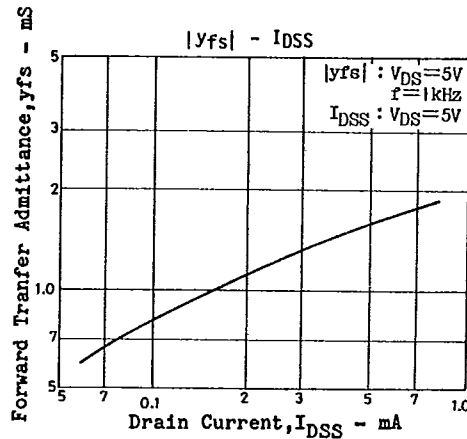
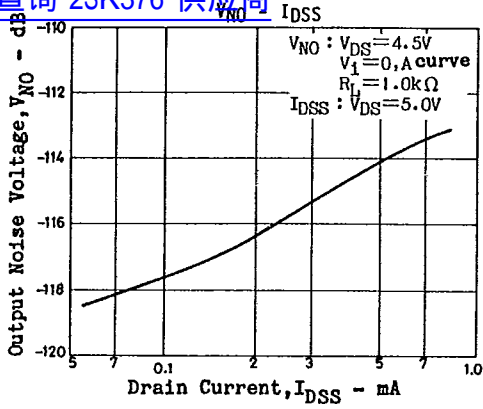

Sample Application Circuit: 2-wire type

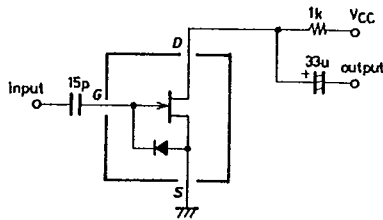

T-91-20

CASE OUTLINES AND ATTACHMENTS

[查询"2SK376"供应商](#)

- All of Sanyo Transistor case outlines are illustrated below.
- All dimensions are in mm, and dimensions which are not followed by min. or max. are represented by typical values.
- No marking is indicated.

Case Outline-[2003A]

unit:mm

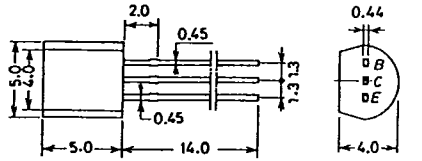

JEDEC: TO-92
EIAJ: SC-43
SANYO: NP

B. Base
C. Collector
E. Emitter

Case Outline-[2009A]

unit:mm

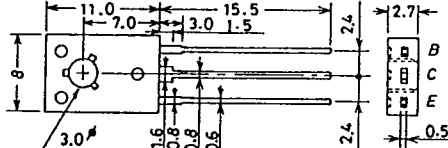

JEDEC: TO-126

B: Base
C: Collector
E: Emitter

Case Outline-[2004A]

unit:mm

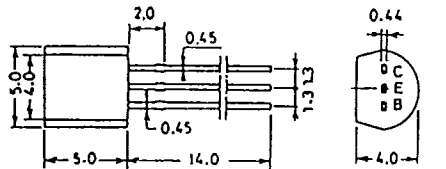

JEDEC: TO-92
EIAJ: SC-43
SANYO: NP

C. Collector
E. Emitter
B. Base

Case Outline-[2010A]

unit:mm

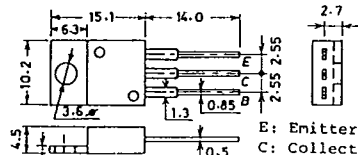

JEDEC: TO-220AB
EIAJ: SC-46

E: Emitter
C: Collector
B: Base

Case Outline-[2005A]

unit:mm

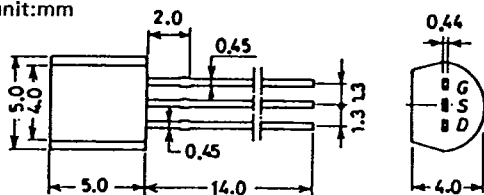

JEDEC: TO-92
EIAJ: SC-43
SANYO: NP

G: Gate
S: Source
D: Drain
B: Base
C: Collector

Case Outline-[2012]

unit:mm

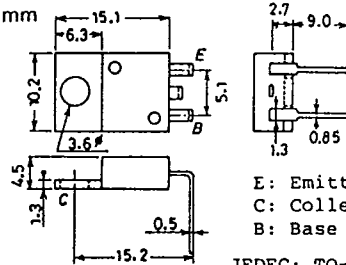

JEDEC: TO-220AA
EIAJ: SC-45

E: Emitter
C: Collector
B: Base

Case Outline-[2006A]

unit:mm

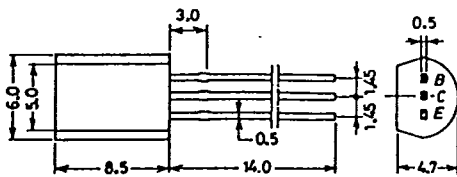

EIAJ: SC-51
SANYO: MP

B: Base
C: Collector
E: Emitter

Case Outline-[2013]

unit:mm

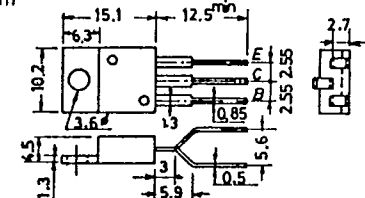

JEDEC TO-220

B: Base
C: Collector
E: Emitter

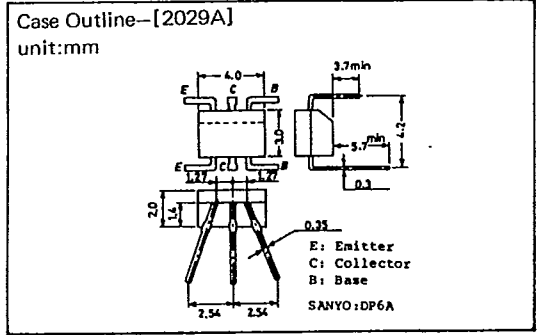
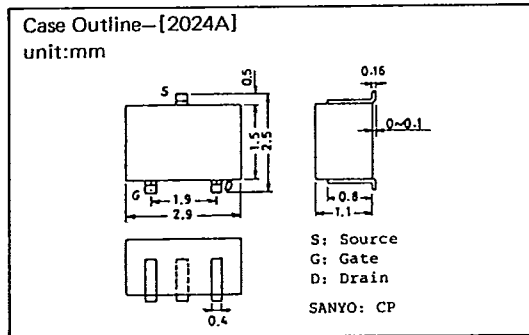
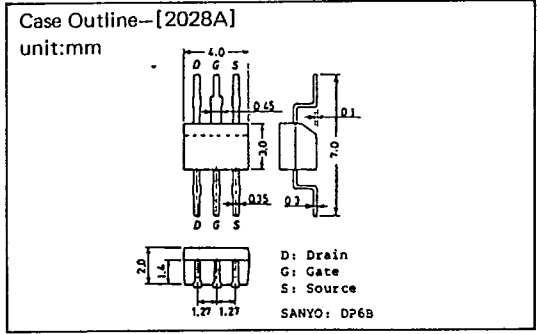
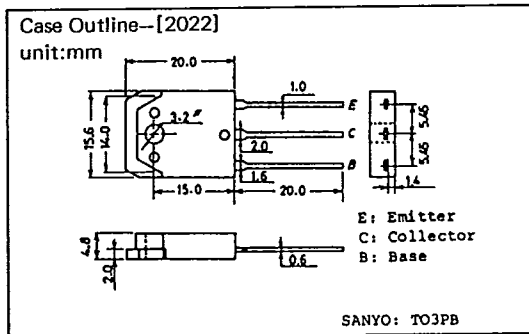
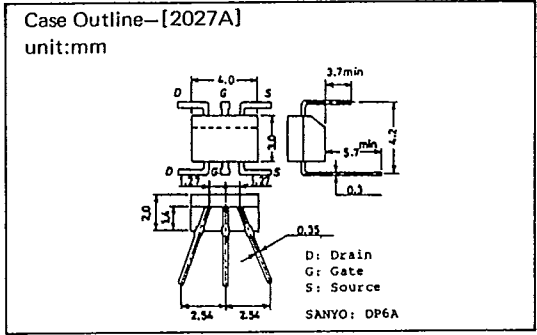
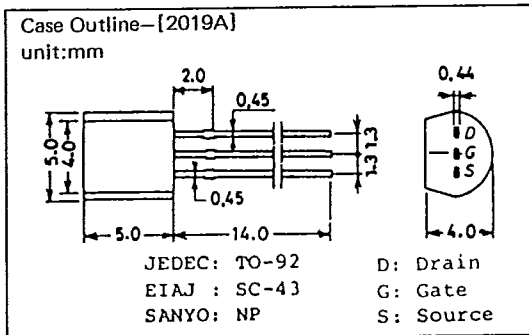
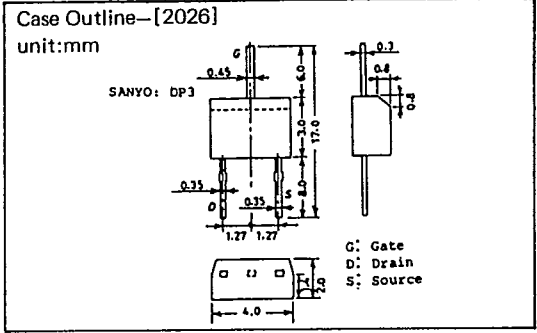
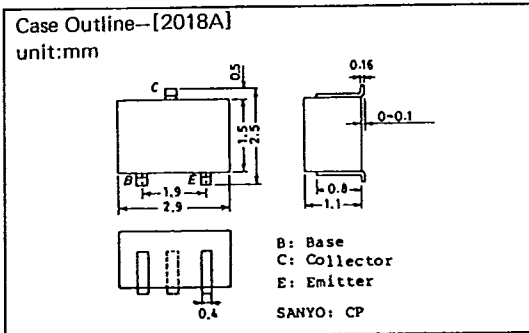
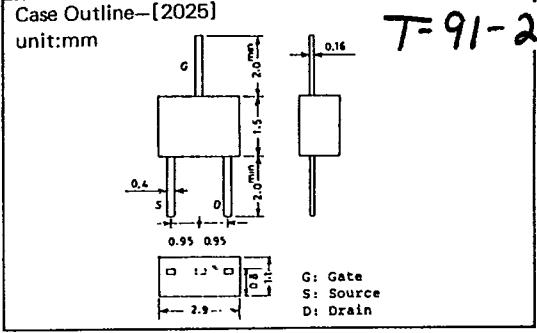
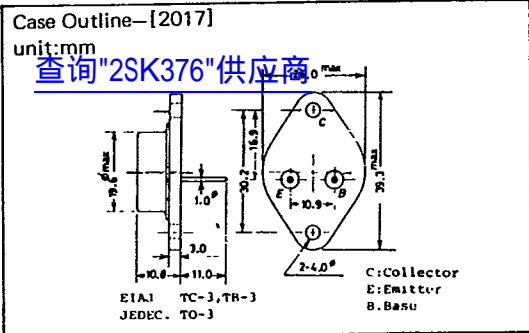

T-91-20

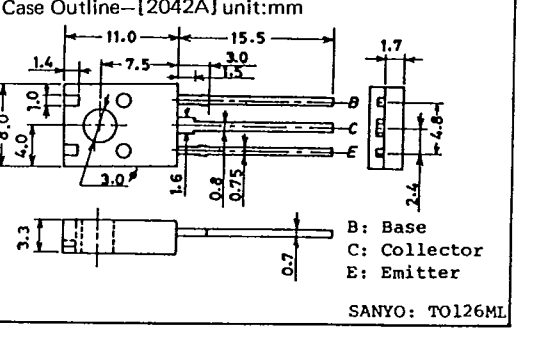
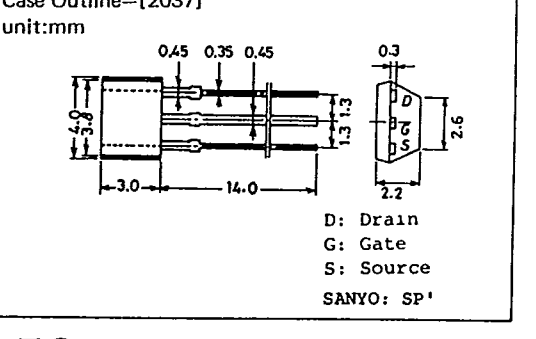
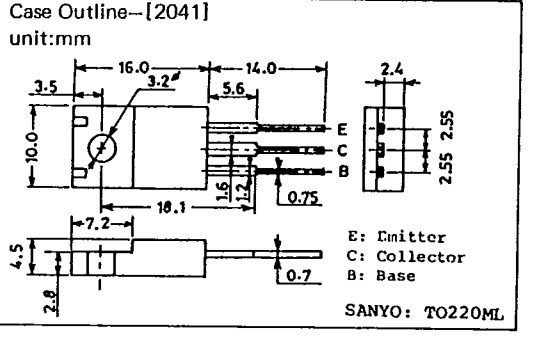
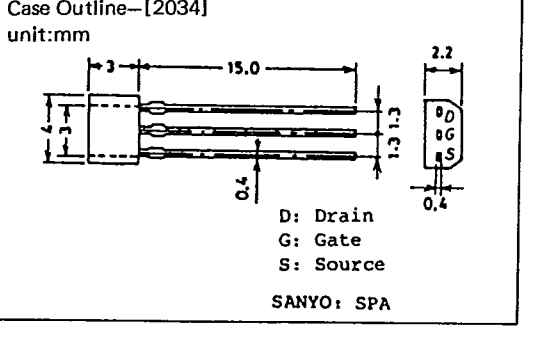
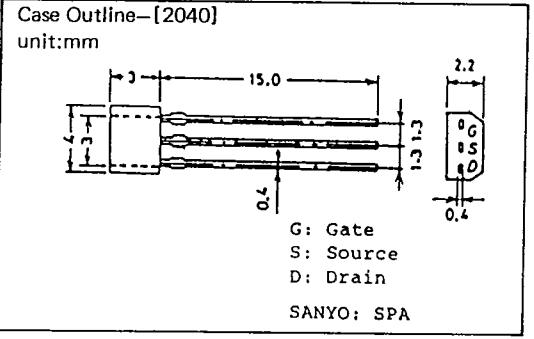
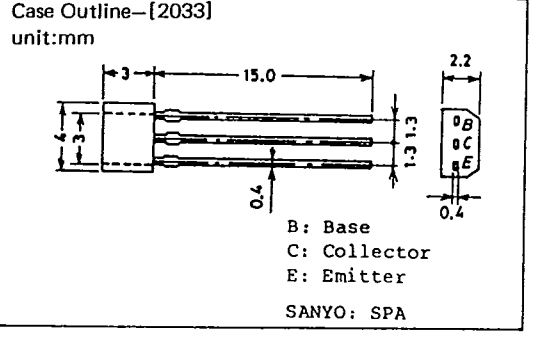
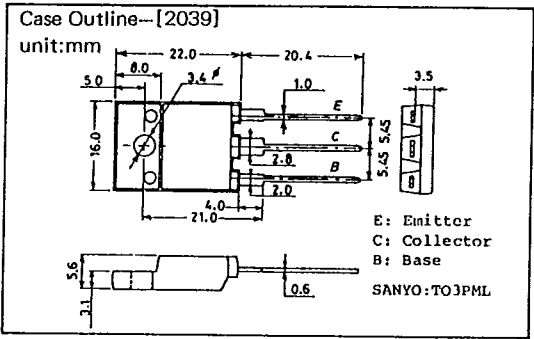
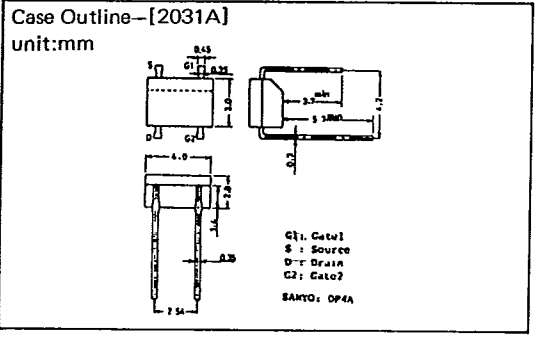
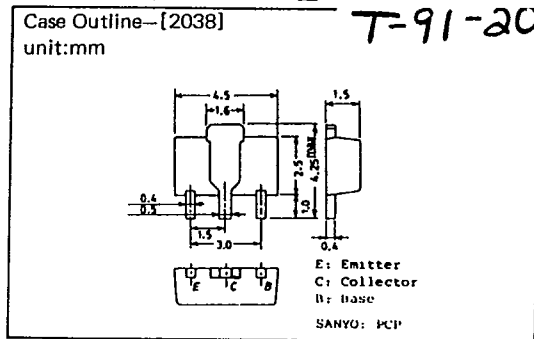
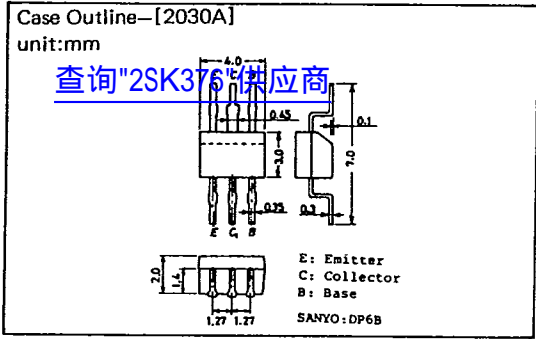

T-91-20

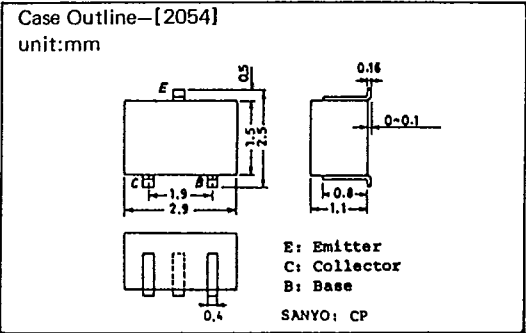
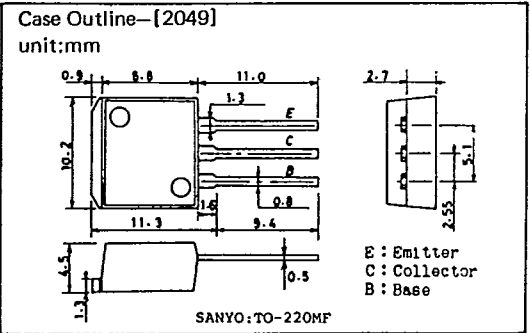
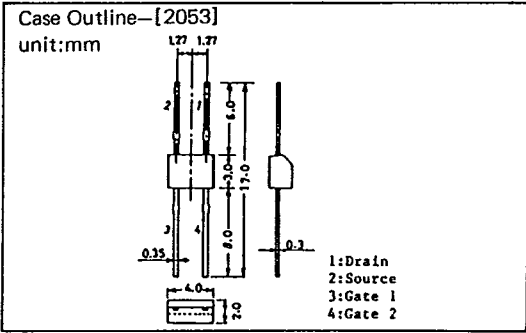
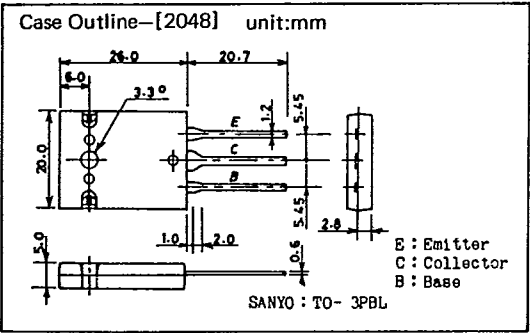
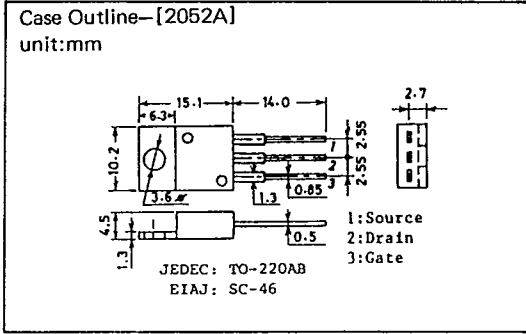
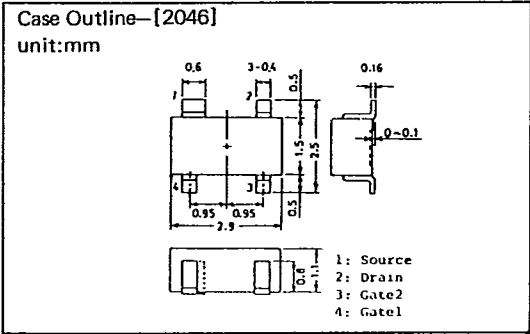
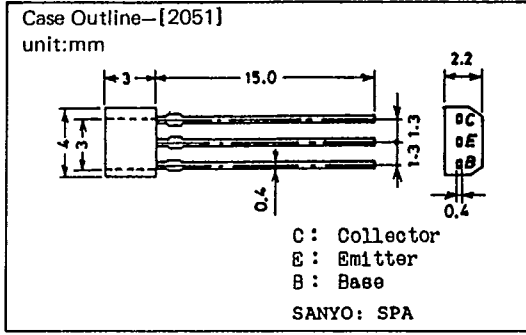
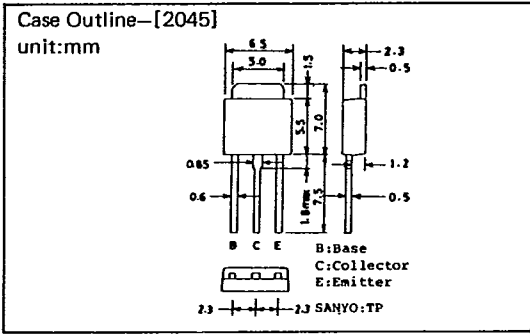
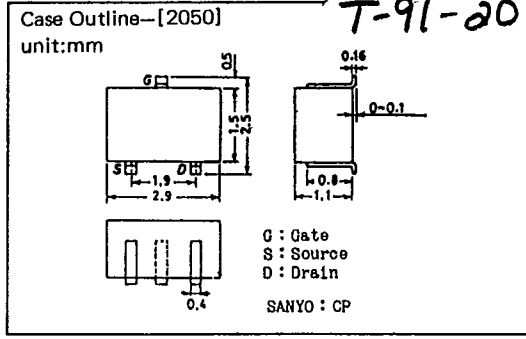
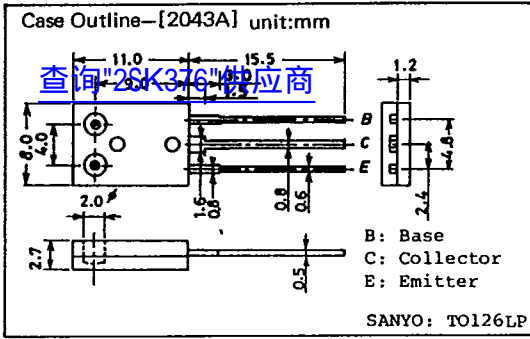

T-91-20

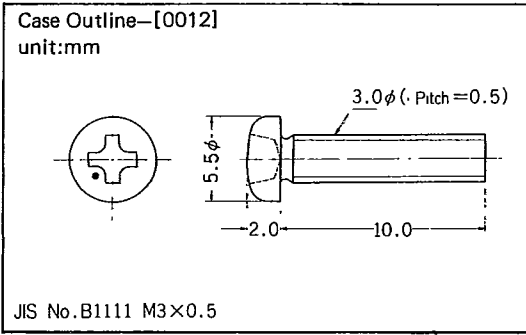
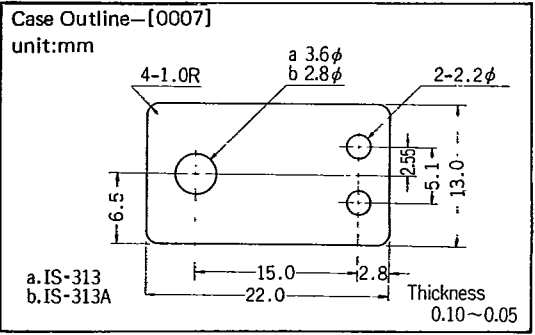
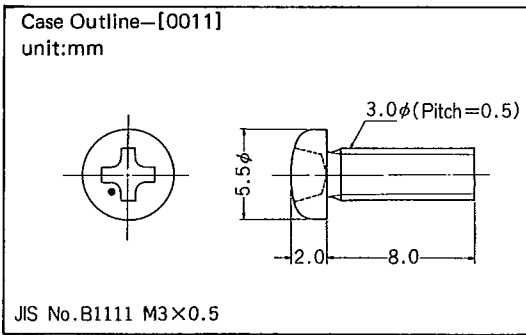
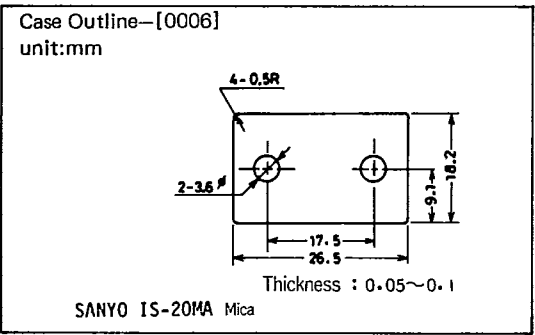
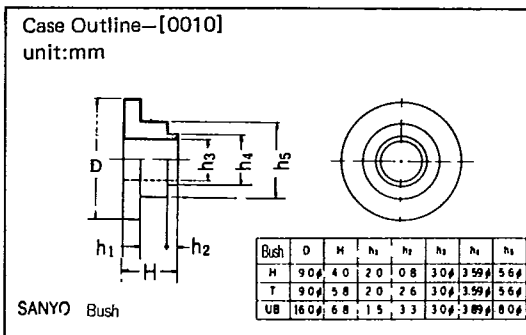
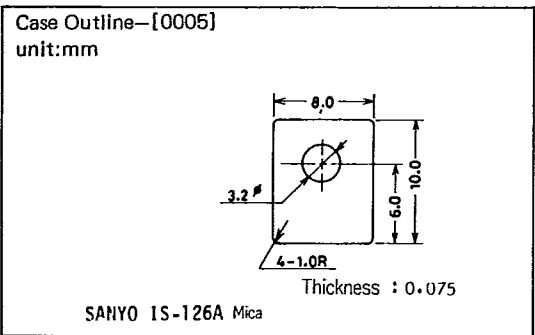
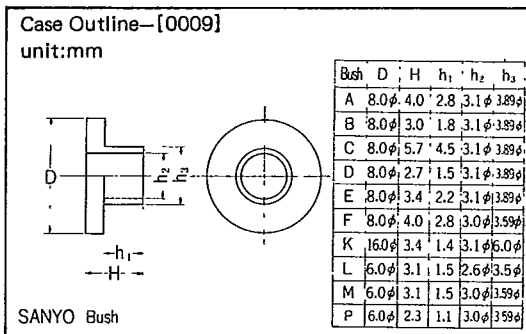
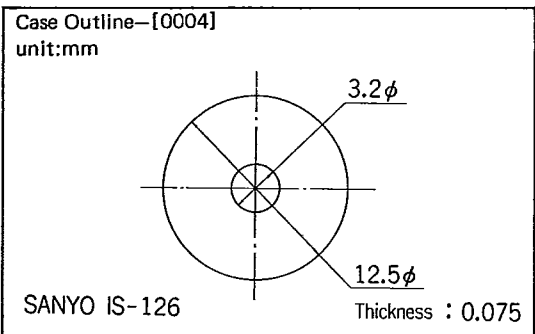
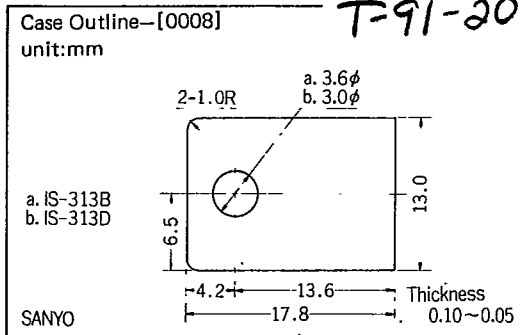
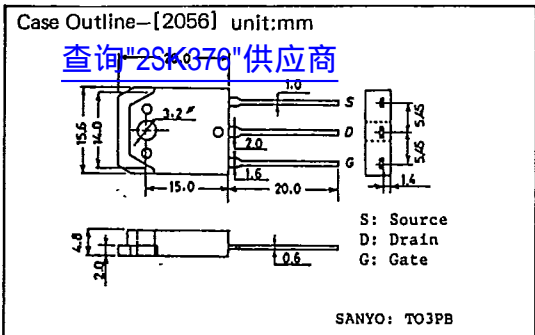

Case Outline-[0013]

unit:mm
[查询"2SK376"供应商](#)

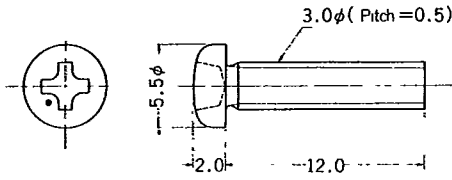

JIS No. B1111 M3×0.5

Case Outline-[0018]

unit:mm

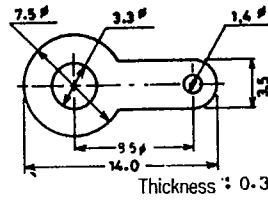

SANYO Lug 1.4

Case Outline-[0014]

unit:mm

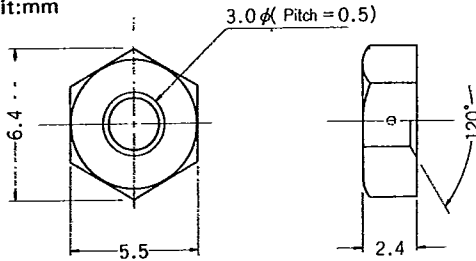

JIS No. B1181 M3×0.5

Case Outline-[0019]

unit:mm

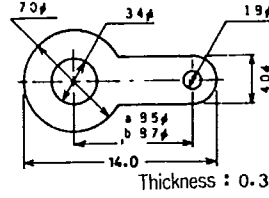

SANYO Lug 1.8φ

Case Outline-[0015]

unit:mm

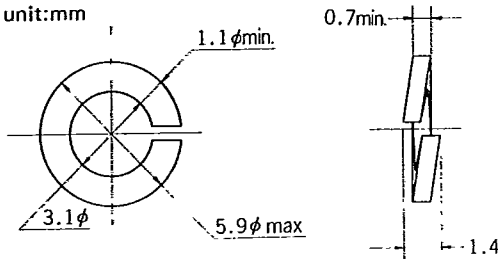

JIS No. B 1251 Spring washer (M3)

Case Outline-[0020]

unit:mm

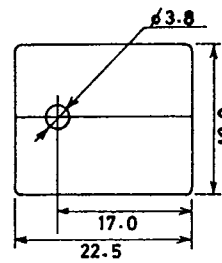

SANYO IS-3MP Mica

Case Outline-[0016]

unit:mm

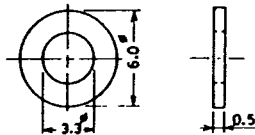

JIS No. B1252 Flat washer

Case Outline-[0021]

unit:mm

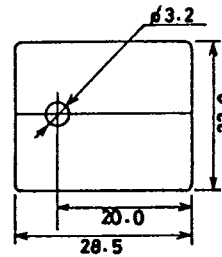

SANYO IS-MPC Mica

Case Outline-[0017]

unit:mm

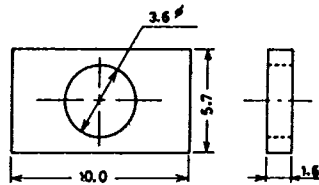

JIS No. G3141 Rectangular washer

Case Outline-[0022]

unit:mm

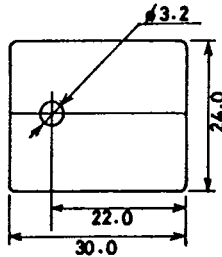

SANYO IS-3PBL Mica