

2SK513



SILICON N-CANNEL MOS FET

HIGH SPEED POWER SWITCHING

www.DataSheet4U.com

■ FEATURES

- High Breakdown Voltage.
- High Speed Switching.
- High Cutoff Frequency.
- No Secondary Breakdown.
- Suitable for Switching Regulator, DC-DC Converter, and Ultrasonic Power Oscillators.

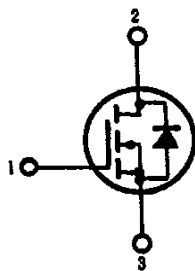

1. Gate
2. Drain (Flange)
3. Source
(Dimensions in mm)

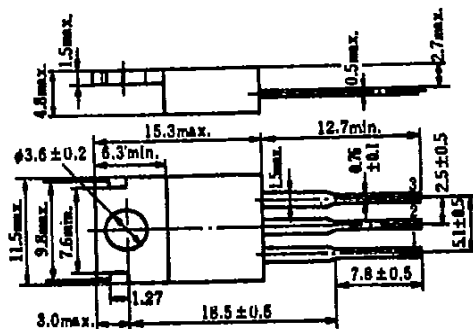

(JEDEC TO-220AB)

■ ABSOLUTE MAXIMUM RATINGS ($T_c=25^\circ\text{C}$)

Item	Symbol	Rating	Unit
Drain-Source Voltage	V_{DS}	800	V
Gate-Source Voltage	V_{GS}	± 20	V
Drain Current	I_D	8	A
Drain Peak Current	$I_{D(peak)}$	6	A
Body-Drain Diode Reverse Drain Current	I_{DR}	8	A
Channel Dissipation	P_{ch}^*	60	W
Channel Temperature	T_{ch}	150	$^\circ\text{C}$
Storage Temperature	T_{stg}	$-55 \sim +150$	$^\circ\text{C}$

*Value at $T_c=25^\circ\text{C}$

POWER VS. TEMPERATURE DERATING

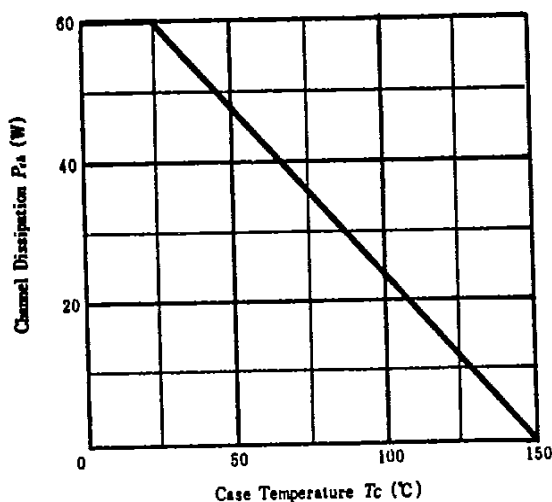

■ ELECTRICAL CHARACTERISTICS ($T_c=25^\circ\text{C}$)

Item	Symbol	Test Condition	min.	typ.	max.	Unit
Drain-Source Breakdown Voltage	$V_{(BR)DS}$	$I_D=10\text{mA}, V_{GS}=0$	800	—	—	V
Gate-Source Leak Current	I_{OSS}	$V_{GS}=\pm 20\text{V}, V_{DS}=0$	—	—	± 1	μA
Zero Gate Voltage Drain Current	I_{DSS}	$V_{DS}=640\text{V}, V_{GS}=0$	—	—	1	mA
Gate-Source Cutoff Voltage	$V_{GS(off)}$	$I_D=1\text{mA}, V_{DS}=10\text{V}$	2.0	—	4.0	V
Static Drain-Source On State Resistance	$R_{DS(on)}$	$I_D=2\text{A}, V_{GS}=15\text{V}^*$	—	5.0	6.0	Ω
Drain-Source Saturation Voltage	$V_{DS(on)}$	$I_D=2\text{A}, V_{GS}=15\text{V}^*$	—	10.0	12.0	V
Forward Transfer Admittance	$ y_f $	$I_D=2\text{A}, V_{DS}=20\text{V}^*$	0.4	0.7	—	S
Input Capacitance	C_{iss}	$V_{DS}=10\text{V}, V_{GS}=0, f=1\text{MHz}$	—	470	—	pF
Output Capacitance	C_{oss}		—	120	—	pF
Reverse Transfer Capacitance	C_{rss}		—	22	—	pF
Turn-on Delay Time	$t_{d(on)}$	$I_D=2\text{A}, V_{GS}=15\text{V}, R_L=15\Omega$	—	15	—	ns
Rise Time	t_r		—	35	—	ns
Turn-off Delay Time	$t_{d(off)}$		—	85	—	ns
Fall Time	t_f		—	35	—	ns
Body-Drain Diode Forward Voltage	V_{DF}	$I_F=2\text{A}, V_{GS}=0$	—	0.9	—	V
Body-Drain Diode Reverse Recovery Time	t_r	$I_F=2\text{A}, V_{GS}=0$ $di_F/dt=100\text{A}/\mu\text{s}$	—	700	—	ns

*Pulse Test

MAXIMUM SAFE OPERATION AREA

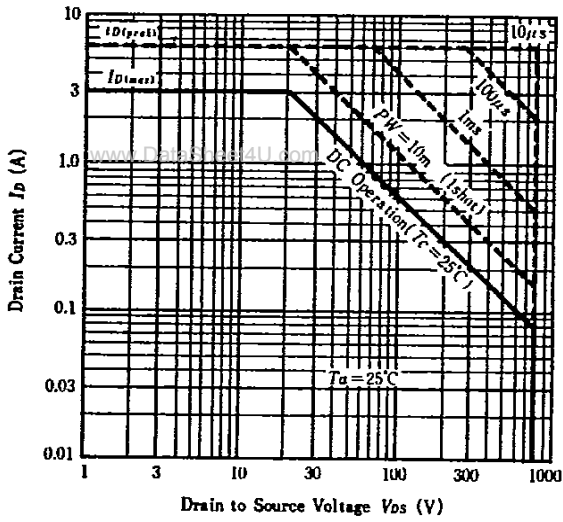

TYPICAL OUTPUT CHARACTERISTICS

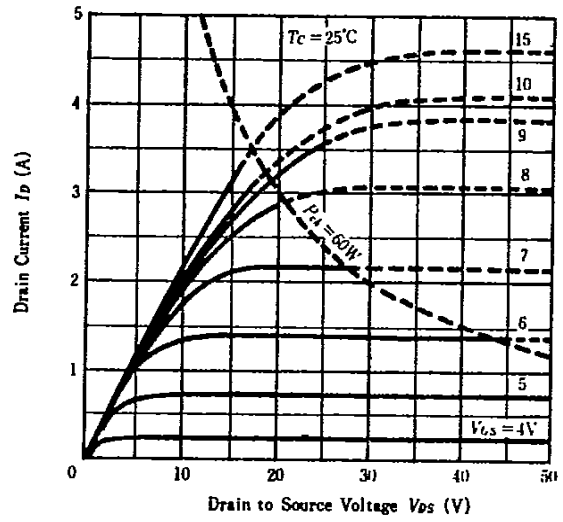

TYPICAL TRANSFER CHARACTERISTICS

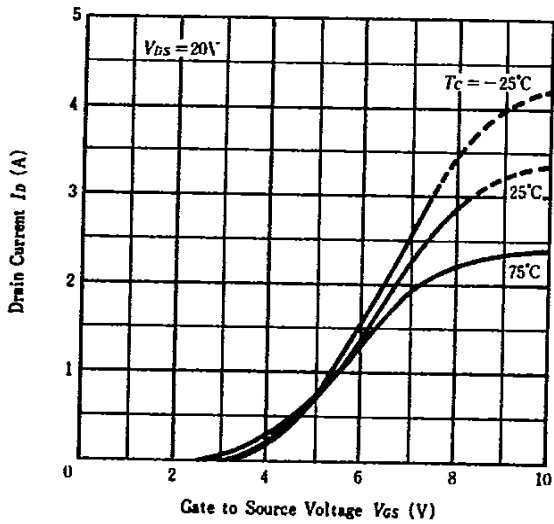

DRAIN-SOURCE SATURATION VOLTAGE VS. GATE-SOURCE VOLTAGE

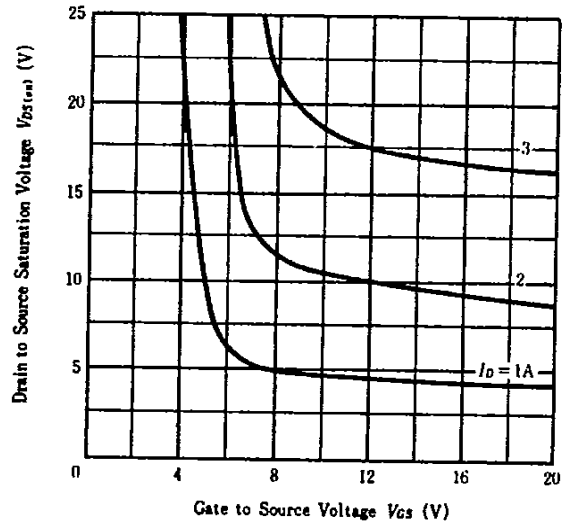

FORWARD TRANSFER ADMITTANCE VS. DRAIN CURRENT

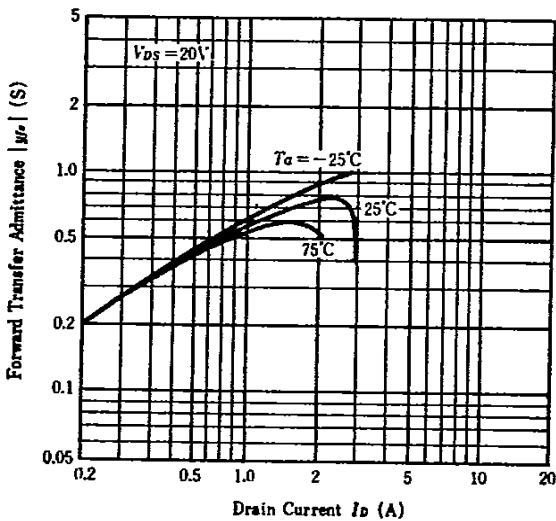

STATIC DRAIN-SOURCE ON STATE RESISTANCE VS. TEMPERATURE

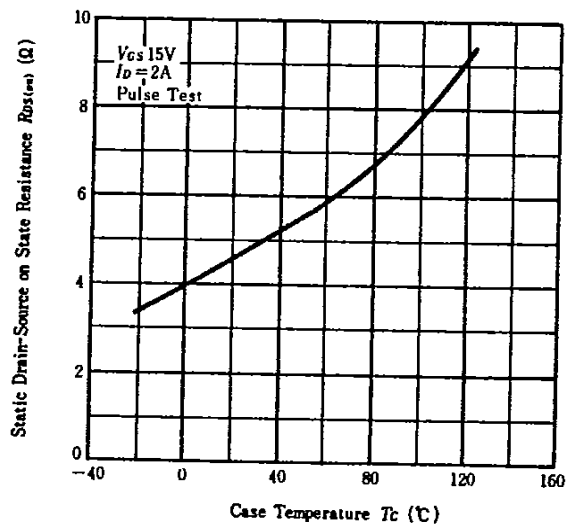

TYPICAL CAPACITANCE VS. DRAIN-SOURCE VOLTAGE

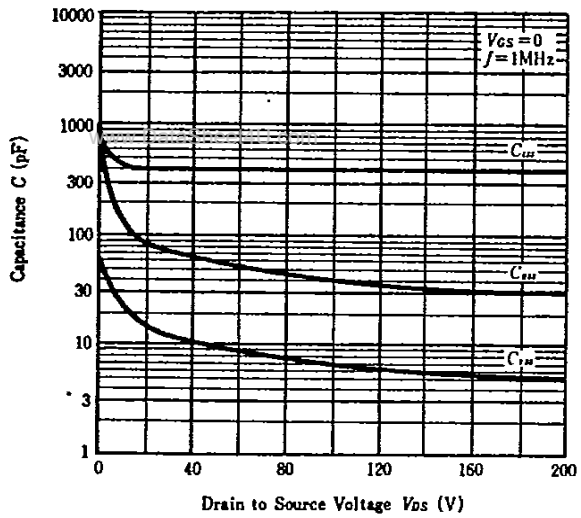

FORWARD TRANSFER ADMITTANCE VS. FREQUENCY

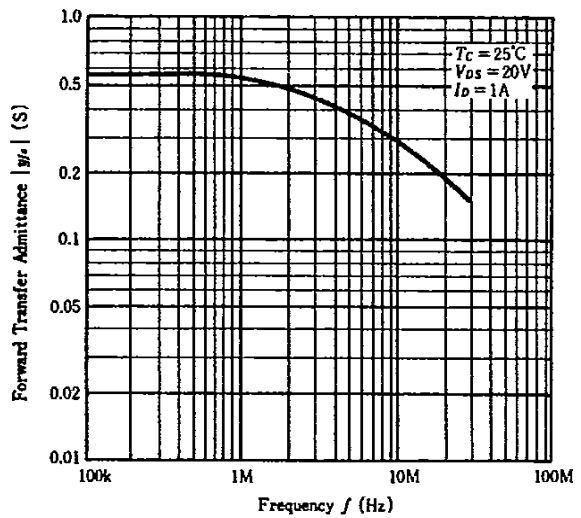

SWITCHING CHARACTERISTICS

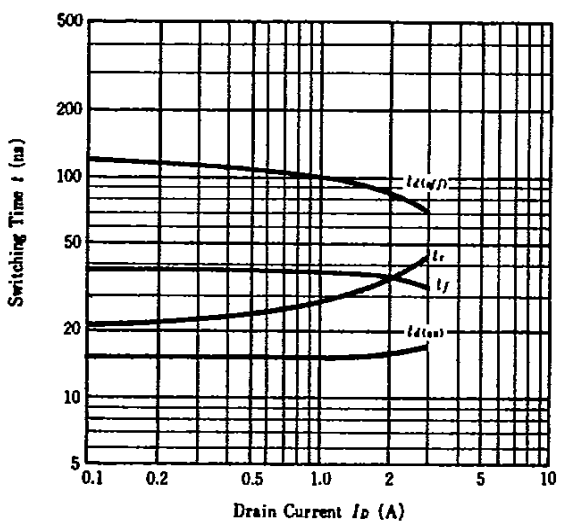

MAXIMUM BODY-DRAIN DIODE FORWARD VOLTAGE

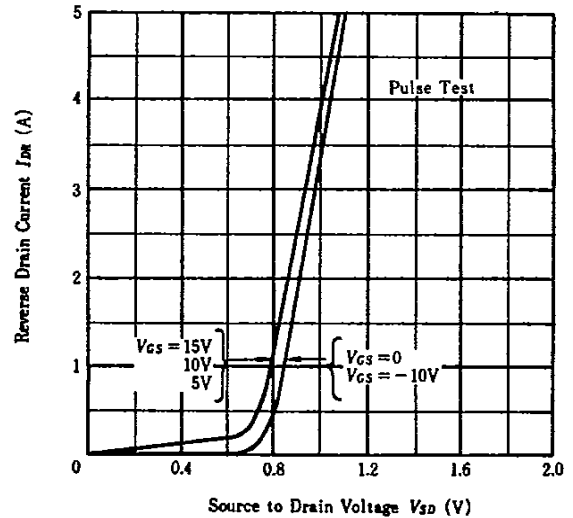

DYNAMIC INPUT CHARACTERISTICS

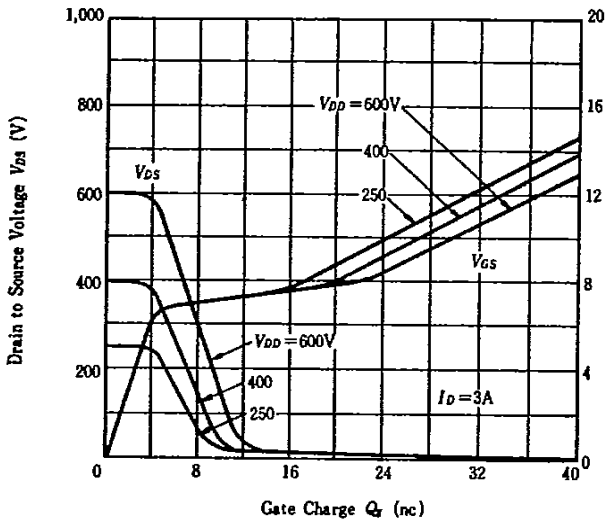

SWITCHING TIME TEST CIRCUIT

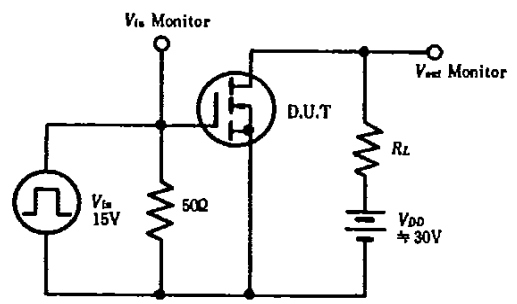

WAVEFORMS

