

isc Silicon NPN Darlington Power Transistor
2ST501T
DESCRIPTION

- Low Collector Saturation Voltage
- High DC Current Gain
- Minimum Lot-to-Lot variations for robust device performance and reliable operation

APPLICATIONS

- Audio power amplifiers
- Relay & solenoid drivers
- Motor controls
- General purpose power amplifiers

ABSOLUTE MAXIMUM RATINGS(T_a=25°C)

SYMBOL	PARAMETER	VALUE	UNIT
V _{CB0}	Collector-Base Voltage	500	V
V _{CEO(SUS)}	Collector-Emitter Voltage	330	V
V _{EBO}	Emitter-Base Voltage	5	V
I _C	Collector Current-Continuous	8	A
I _B	Base Current-Continuous	12	A
P _C	Collector Power Dissipation @ T _C =25°C	100	W
T _J	Junction Temperature	150	°C
T _{stg}	Storage Temperature Range	-55~150	°C

THERMAL CHARACTERISTICS

SYMBOL	PARAMETER	MAX	UNIT
R _{th j-c}	Thermal Resistance, Junction to Case	1.25	°C/W

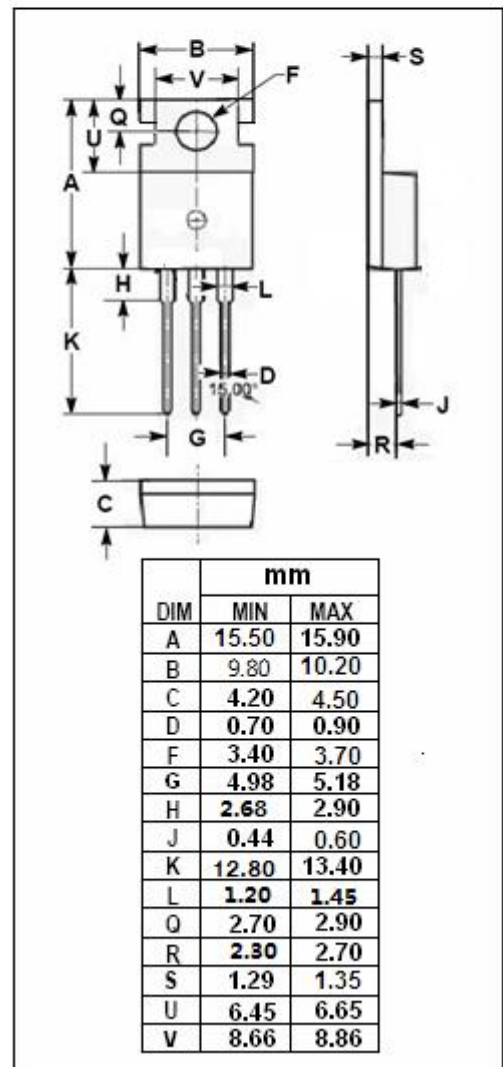
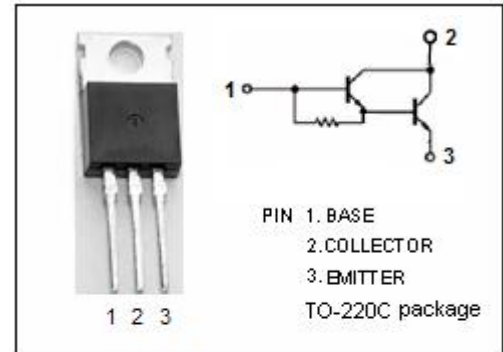

isc Silicon NPN Darlington Power Transistor
2ST501T
ELECTRICAL CHARACTERISTICS

 T_c=25°C unless otherwise specified

SYMBOL	PARAMETER	CONDITIONS	MIN	TYP.	MAX	UNIT
V _{(BR)EBO}	Emitter-Base Breakdown Voltage	I _E = 150mA; I _C = 0	6			V
V _{CEO(sus)}	Collector-Emitter Sustaining Voltage (I _B = 0)	I _C = 10 mA,	330			V
I _{CEO}	Collector Cut-off Current (I _B = 0)	V _{CE} = 300 V			0.1	mA
I _{CBO}	Collector Cutoff Current	V _{CB} = 300V; I _E = 0			0.1	mA
I _{EBO}	Emitter Cutoff Current	V _{EB} = 6V; I _C =0			2	mA
h _{FE}	DC Current Gain	I _C = 2A; V _{CE} = 2V	2000			
V _{CE(sat)}	Collector-Emitter Saturation Voltage	I _C = 2A; I _B = 2mA			1.5	V
V _{BE(sat)}	Base-Emitter Saturation Voltage	I _C = 2A; I _B = 2mA			2.0	V

NOTICE:

ISC reserves the rights to make changes of the content herein the datasheet at any time without notification. The information contained herein is presented only as a guide for the applications of our products.

ISC products are intended for usage in general electronic equipment. The products are not designed for use in equipment which require specialized quality and/or reliability, or in equipment which could have applications in hazardous environments, aerospace industry, or medical field. Please contact us if you intend our products to be used in these special applications.

ISC makes no warranty or guarantee regarding the suitability of its products for any particular purpose, nor does ISC assume any liability arising from the application or use of any products, and specifically disclaims any and all liability, including without limitation special, consequential or incidental damages.