

2W005 THRU 2W10

GLASS PASSIVATED SINGLE-PHASE BRIDGE RECTIFIER

VOLTAGE 50 to 1000 Volts **CURRENT** 2.0 Amperes

FEATURES

- Plastic material used carries Underwriters Laboratory recognition 94V-0
- Low leakage
- Surge overload rating-- 30 amperes peak
- Ideal for printed circuit board
- Exceeds environmental standards of MIL-S-19500/228
- Lead free in comply with EU RoHS 2011/65/EU directives
- Green molding compound as per IEC61249 Std. . (Halogen Free)

MECHANICAL DATA

Case: Reliable low cost construction utilizing molded plastic technique results in inexpensive product

Terminals: Lead solderable per MIL-STD-750, Method 2026

Polarity: Polarity symbols molded or marking on body

Mounting Position: Any

Weight: 0.02 ounce, 0.4 gram

WOB Unit : inch (mm)

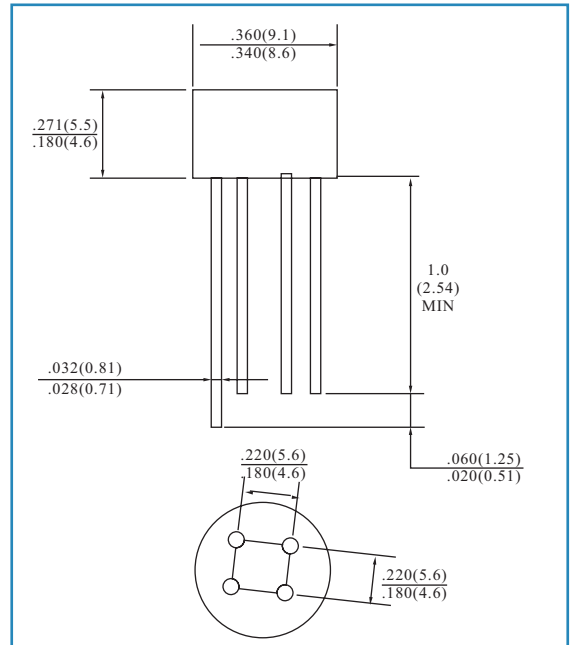

MAXIMUM RATINGS AND ELECTRICAL CHARACTERISTICS

Maximum Ratings & Electrical Characteristics Ratings at 25°C ambient temperature unless otherwise specified

	SYMBOLS	2W005	2W01	2W02	2W04	2W06	2W08	2W10	UNITS
最大可重复峰值反向电压 Maximum repetitive peak reverse voltage	VRRM	50	100	200	400	600	800	1000	Volts
最大均方根电压 Maximum RMS voltage	VRMS	35	70	140	280	420	560	700	Volts
最大直流阻断电压 Maximum DC blocking voltage	VDC	50	100	200	400	600	800	1000	Volts
最大正向平均整流电流 Maximum average forward output rectified	I(AV)	2.0							Amps
正向峰值浪涌电流 8.3ms 单一正弦半波 Peak forward surge current 8.3ms single half sine-wave	IFSM	60							Amps
最大正向电压降 Maximum forward voltage	VF	1.05							Volts
最大反向漏电流 Maximum reverse voltage	IR	5.0 500							μ A
典型结电容 Type junction capacitance VR=4.0V f=1.0MHz	CJ	14							pF
工作温度和存储温度 Operating junction and storage temperature range	TJ.TSTG	-55 to + 150							°C

2W005 THRU 2W10

RATING AND CHARACTERISTIC CURVES

Fig. 1 Derating Curve for Output Rectified Current

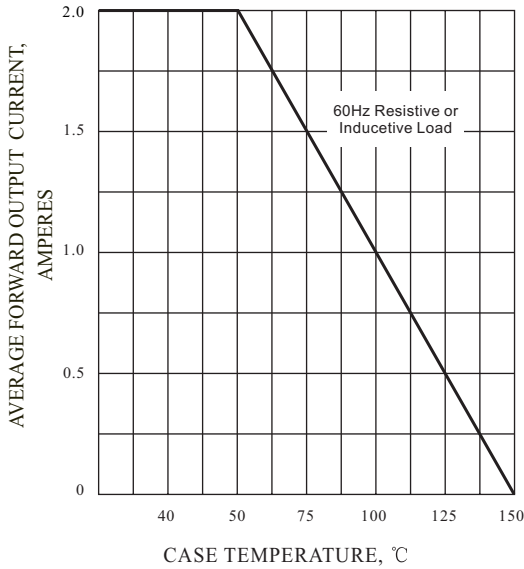

Fig. 2 Maximum Non-repetitive Peak Forward Surge Current

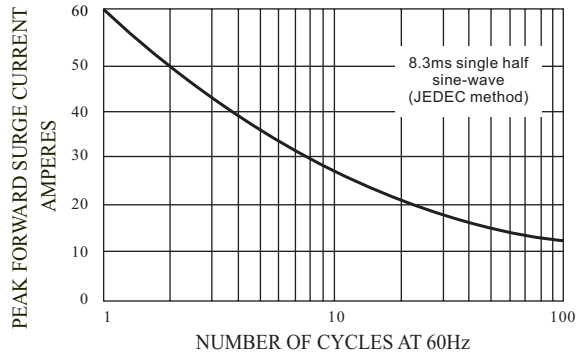

Fig. 4 Typical Reverse Characteristics

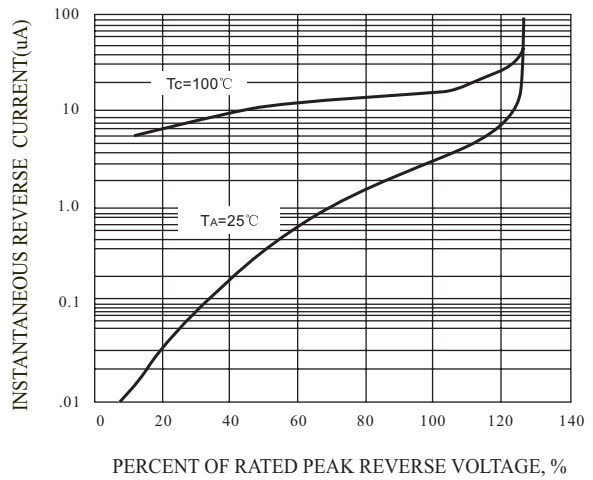

Fig. 3 Typical Instantaneous Forward Characteristics

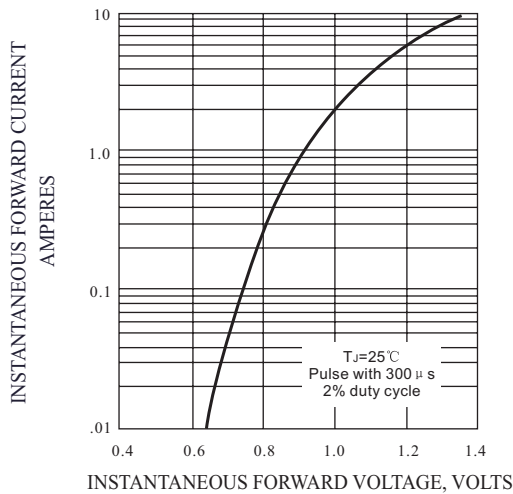

Fig. 5 Typical Junction Capacitance

