

## GLASS PASSIVATED BRIDGE RECTIFIERS

REVERSE VOLTAGE - **50 to 1000** Volts  
FORWARD CURRENT - **2.0** Amperes

### FEATURES

- Surge overload rating -60 amperes peak
- Ideal for printed circuit board
- Reliable low cost construction utilizing molded plastic technique results in expensive product
- Mounting Position :Any
- Lead:sliver plated copper lead.

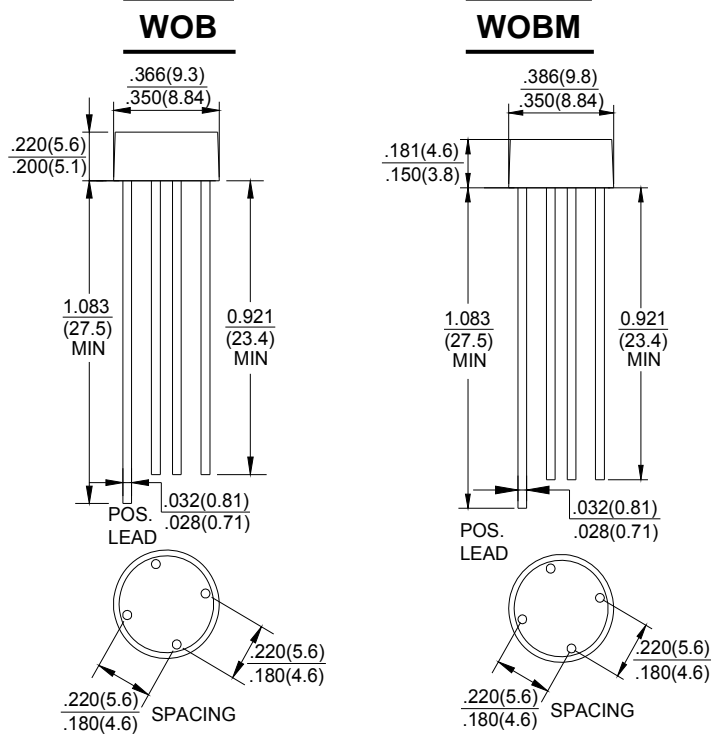

Dimensions in inches and (millimeters)

### MAXIMUM RATINGS AND ELECTRICAL CHARACTERISTICS

Rating at 25°C ambient temperature unless otherwise specified.

Single phase, half wave ,60Hz, resistive or inductive load.

For capacitive load, derate current by 20%

CHARACTERISTICS	SYMBOL	2W005G	2W01G	2W02G	2W04G	2W06G	2W08G	2W10G	UNIT
		2W005MG	2W01MG	2W02MG	2W04MG	2W06MG	2W08MG	2W10MG	
Maximum Recurrent Peak Reverse Voltage	V <sub>RRM</sub>	50	100	200	400	600	800	1000	V
Maximum RMS Bridge Input Voltage	V <sub>RMS</sub>	35	70	140	280	420	560	700	V
Maximum DC Blocking Voltage	V <sub>DC</sub>	50	100	200	400	600	800	1000	V
Maximum Average Forward Rectified Current @T <sub>A</sub> =25°C	I <sub>(AV)</sub>	2.0							A
Peak Forward Surge Current , 8.3ms Single Half Sine-Wave Super Imposed on Rated Load	I <sub>FSM</sub>	60							A
I <sup>2</sup> t Rating for Fusing (t<8.3ms)	I <sup>2</sup> t	15.0							A <sup>2</sup> s
Maximum Forward Voltage Drop per Element at 2.0A Peak	V <sub>F</sub>	1.1							V
Maximum Reverse Current at Rated DC Blocking Voltage T <sub>J</sub> =25°C	I <sub>R</sub>	10.0							μA
		1.0							mA
Typical Junction Capacitance Per Element (Note1)	C <sub>J</sub>	30							pF
Operating Temperature Range	T <sub>J</sub>	-55 to +150							°C
Operating Temperature Range	T <sub>STG</sub>	-55 to +150							°C

Note:1. Measured at 1.0MHz and applied reverse voltage of 4.0V DC.

2. The typical data above is for reference only(典型值仅供参考).

FIG.1-FORATING CURVE  
 OUTPUT RECTIFIED  
 CURRENT

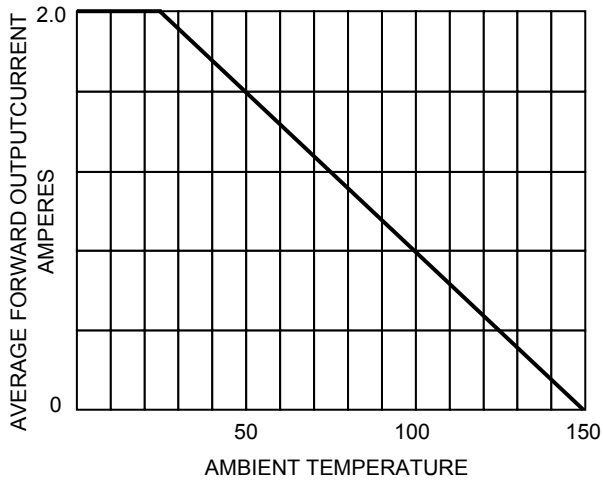

FIG.2-MAXIMUM NON-REPETITIVE PEAK  
 FORWARD SURGE CURRENT

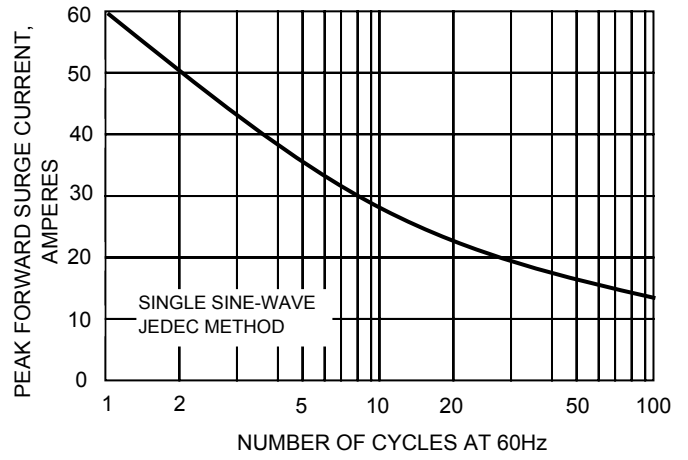

FIG.3-TYPIACL REVERSE CHARACTERISTICS

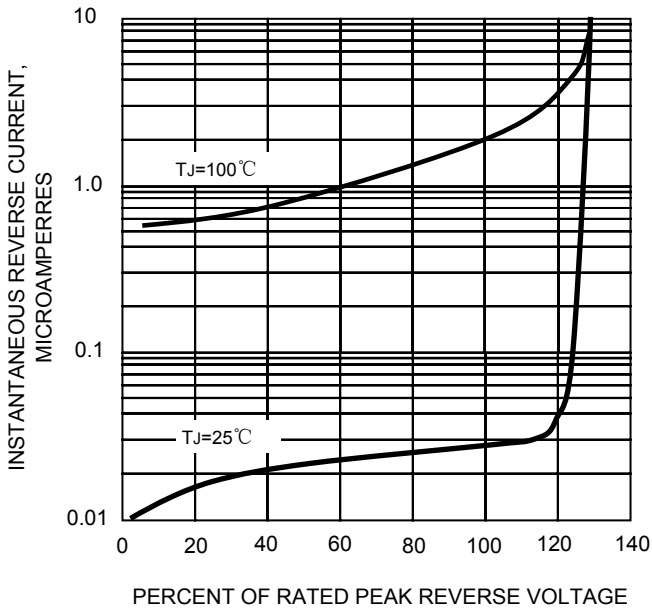

FIG.4-TYPICAL FORWARD  
 CHARACTERISTICS

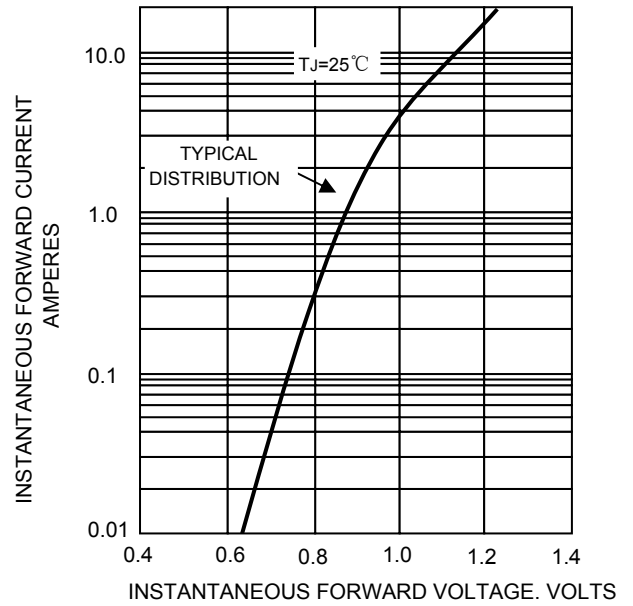
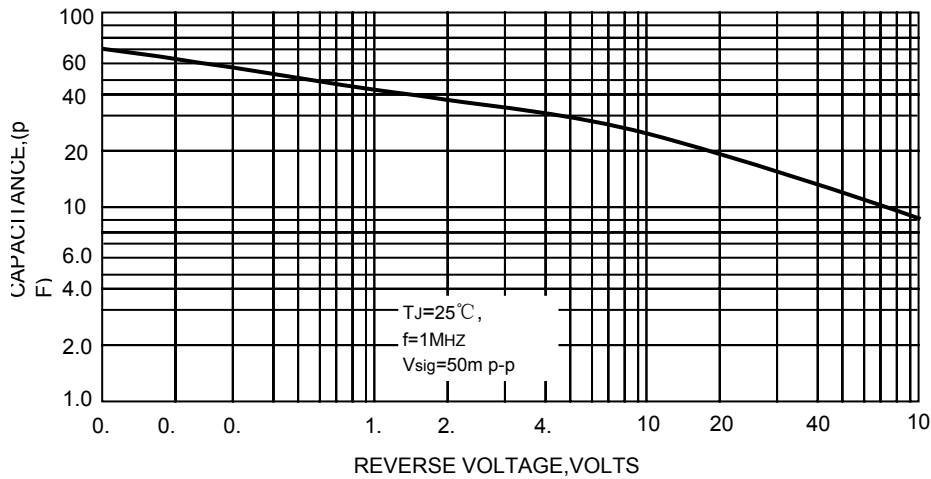

FIG.5-TYPICAL JUNCTION CAPACITANCE PER BRIDGE



The cruve graph is for reference only, can't be the basis for judgment(曲线图仅供参考)!