

# 3205

## product description

FHP3205 is a low-voltage high-current power MOS field effect transistor, widely used in power inverters

## Features

110A, 55V,  $R_{DS(on)} = 8.0m\Omega$  fast switching speed

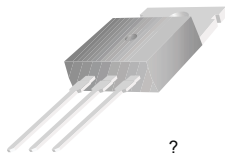

Available  
**RoHS\***  
COMPLIANT

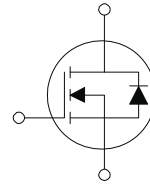

## Limit value (TC=25°C)

parameter name	symbol	Parameter value	unit
Drain-source voltage	$V_{DS}$	55	V
Drain current @Tc=25°C	$I_D$	110	A
Gate-source voltage	$V_{GS}$	$\pm 20$	V
Dissipated power @Tc=25°C	$P_D$	200	W
Junction temperature	$T_J$	175	°C
Storage temperature	$T_{stg}$	-55 ~ 175	°C
avalanche	$E_{AS}$	20	mJ

## Dynamic characteristic value

Parameter Description	symbol	Test Conditions	Minimum value	Typical value	maximum	unit
Input capacitance Output	$C_{iss}$	$V_{DS}=25v, V_{GS}=0v, f=1.0 MHz$	--	3247	--	pF
capacitance Reverse	$C_{oss}$	$V_{DS}=25v, V_{GS}=0v, f=1.0 MHz$	--	781	--	pF
transmission capacitance	$C_{rss}$	$V_{DS}=25v, V_{GS}=0v, f=1.0 MHz$	--	211	--	pF

	$B_{V_{DS}}$	$V_{GS}=0V, I_D=250\mu A$	55	--	--V	
	$I_{DSS}$	$V_{DS}=55V, V_{GS}=0V$	--	--	25	$\mu A$
	$I_{GSS(F/R)}$	$V_{GS}=20V, V_{DS}=0V$	--	--	100	nA
	$R_{DS(ON)}$	$V_{GS}=10V, I_D=62A$	--	--	8.0	
	$V_{GS(th)}$	$V_{DS}=V_{GS}, I_D=250\mu A$	2.0	--	4.0 V	
	$g_{FS}$	$I_D=62A, V_{DS}=25V$	44	--	--S	

	$Q_g$	$V_{DS}=44V$ $I_D=62A$ $V_{GS}=10V$	--	--	146	nC
	$Q_{gs}$		--	--	35	nC
	$Q_{gd}$		--	--	54	nC

( )	$T_d(on)$	$V_{DD}=28V$ $I_D=62A$ $R_G=4.5?$ $V_{GS}=10V$	--	14	--	ns
	$T_r$		--	101	--	ns
	$T_d(off)$		--	50	--	ns
	$t_f$		--	65	--	ns

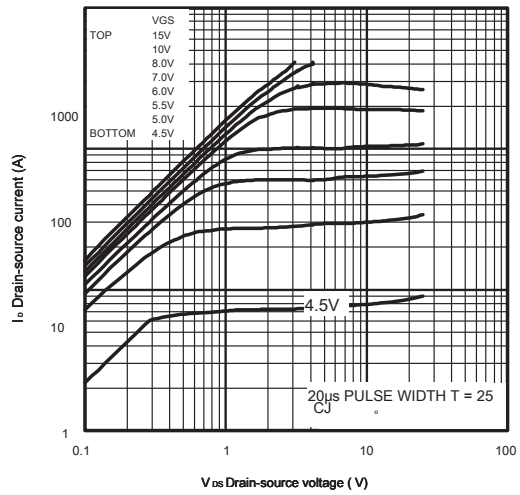

Fig 1. Output characteristics

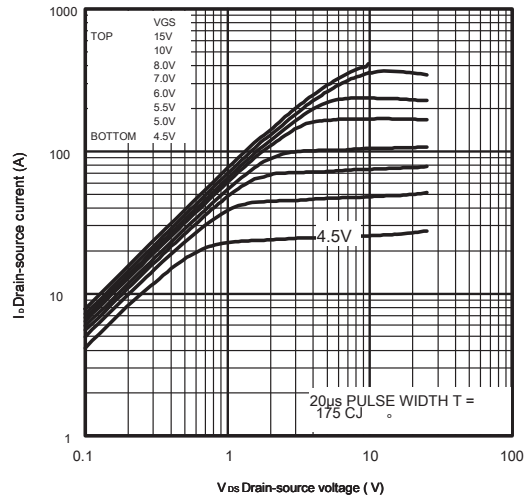

Fig 2. Output characteristics

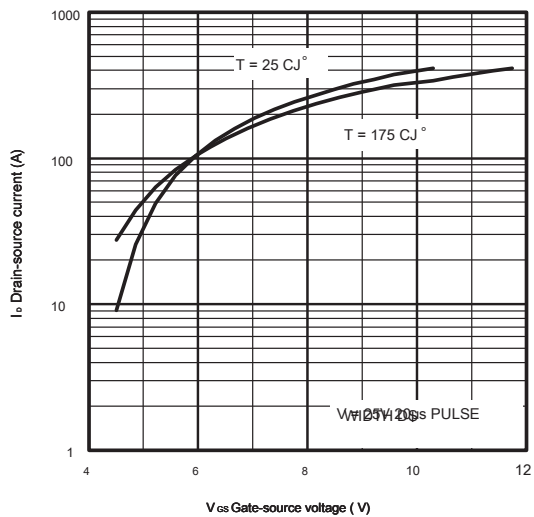

Fig 3. Change characteristics

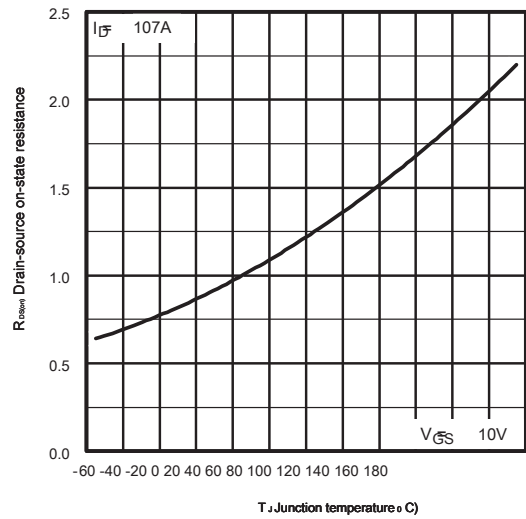

Fig 4. On-state resistance vs. temperature

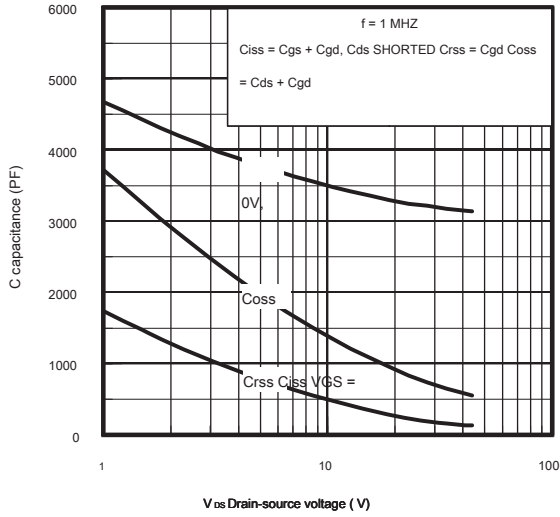

Fig 5. Relationship between capacitance and drain-source voltage

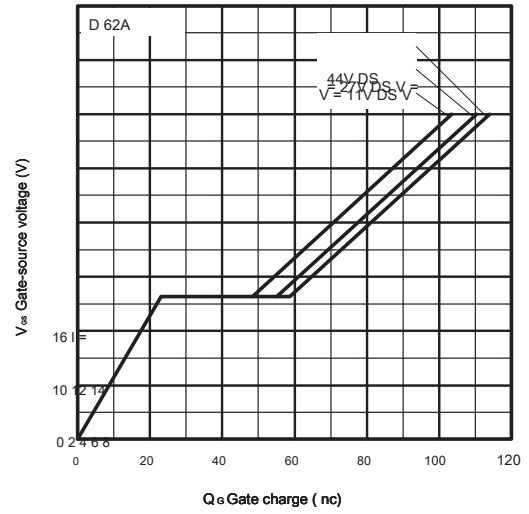

Fig 6. Gate charge vs. gate-source voltage

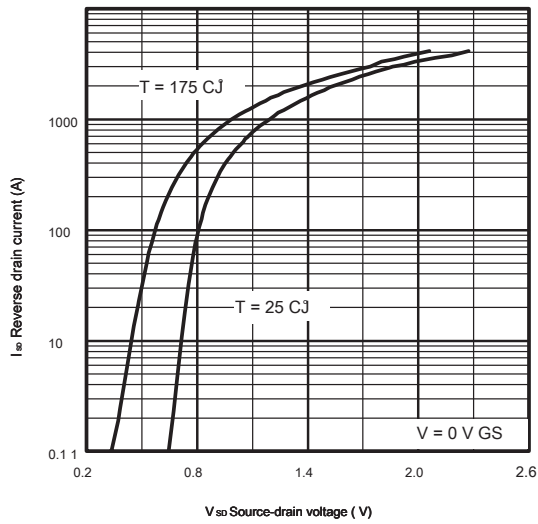

Fig 7. Source-drain diode forward characteristics

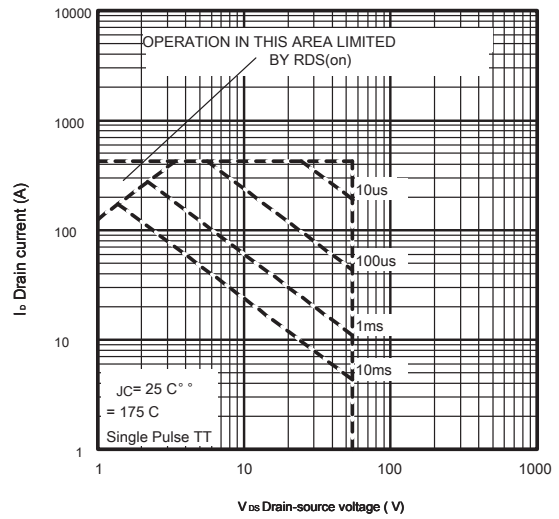

Fig 8. Maximum safe use range

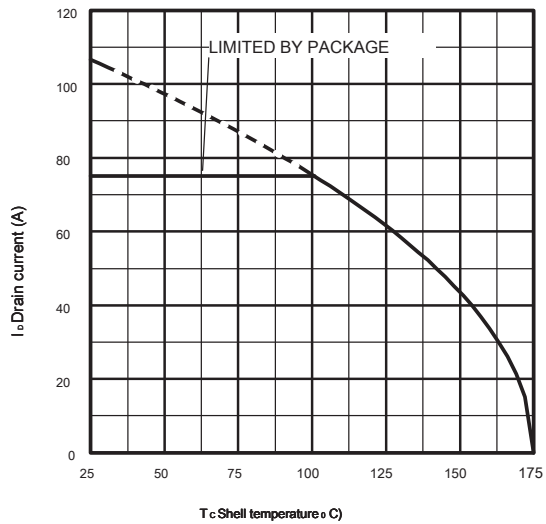

Fig 9. Relationship between maximum drain capacitance and case temperature

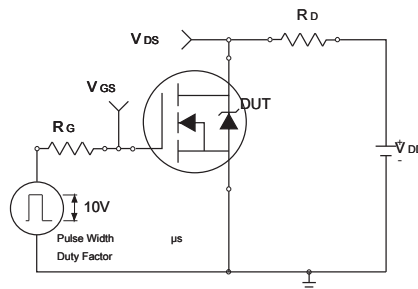

Fig 10a. Switch test circuit

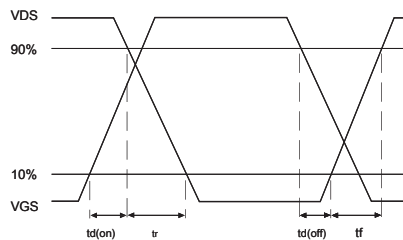

Fig 10b. Switching time waveform

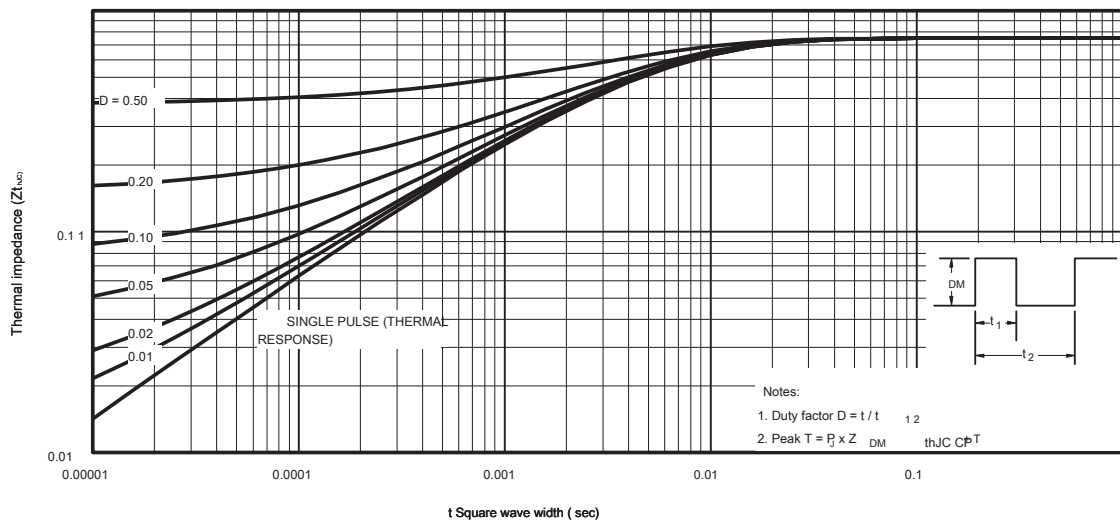

Fig 11. Maximum thermal impedance change

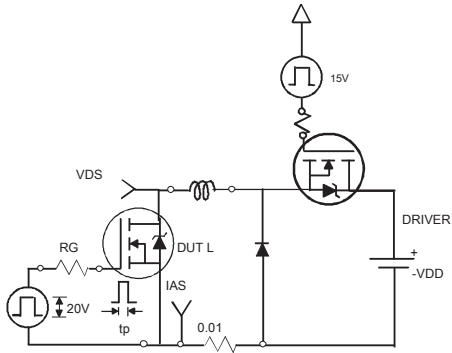

Fig 12a. Unlimited inductance test circuit

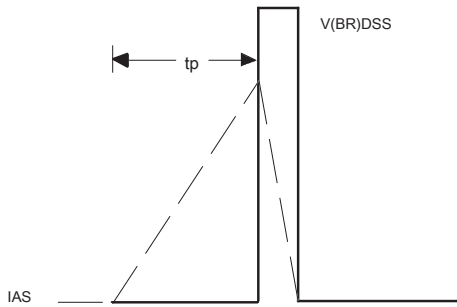

Fig 12b. Test waveform

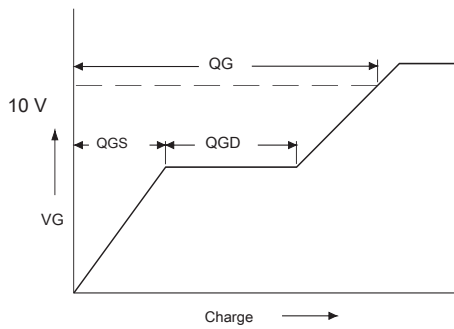

Fig 13a. Gate charge curve

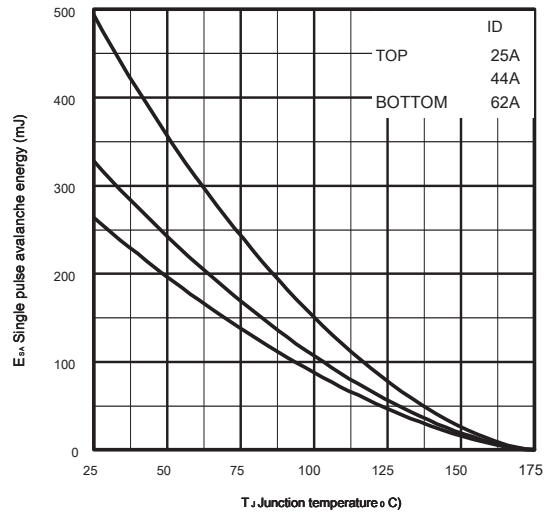

Fig 12c. Relationship between maximum avalanche energy and drain current

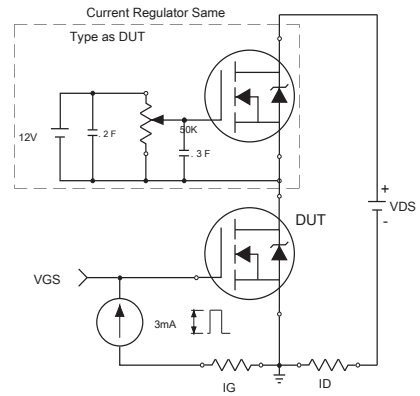
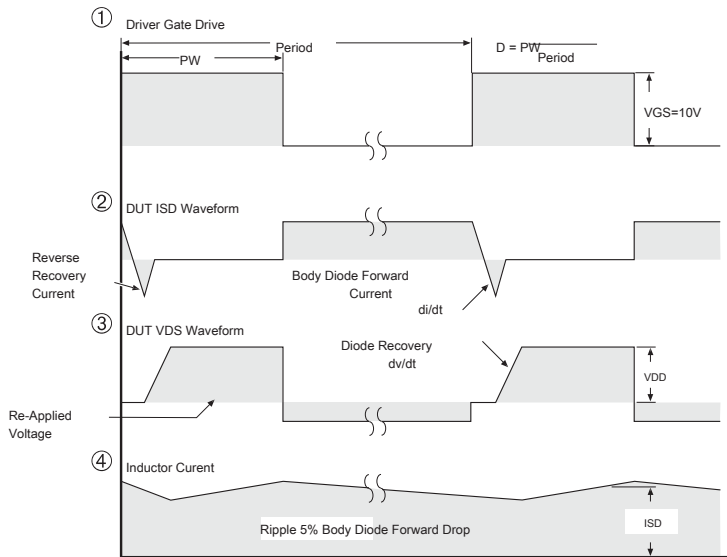
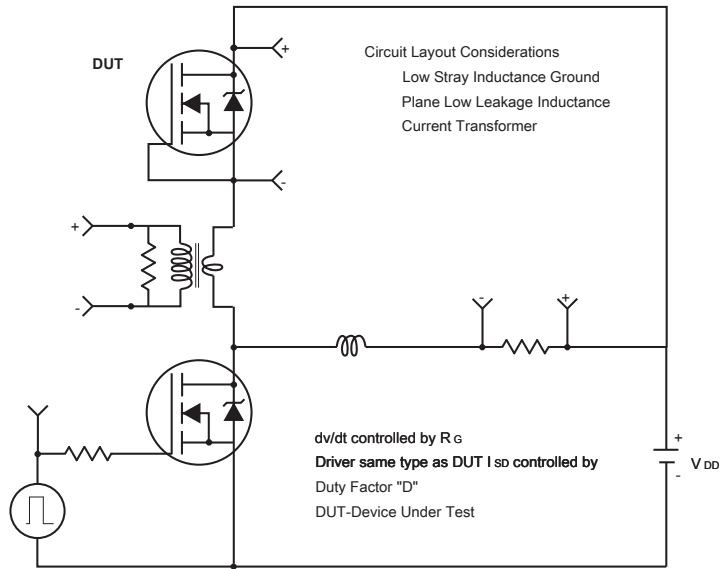

Fig 13b. Gate charge test circuit

Diode reverse recovery characteristics dv/dt Test circuit



\*  $V_{GS} = 5V$  for Logic Level Devices  $R_g$

Fig 14. Test waveform

Dimensions

3 ???

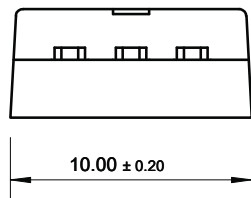
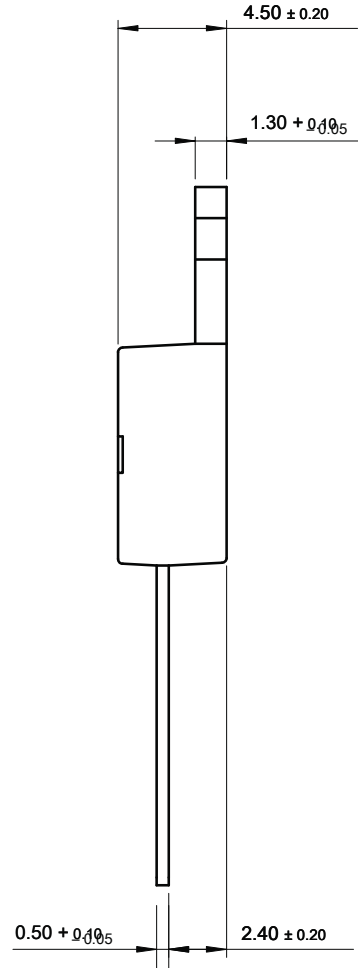
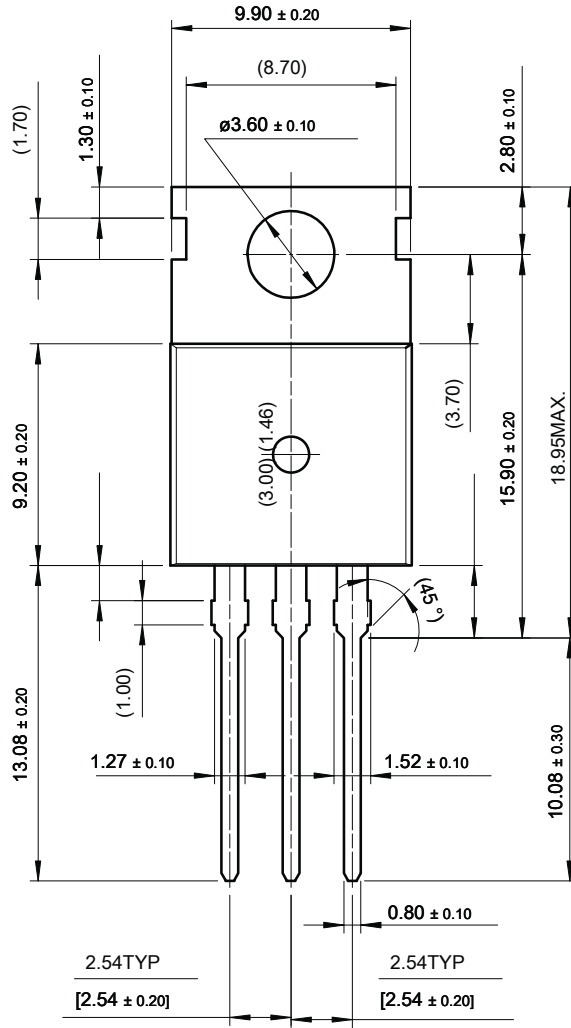

Dimensions: mm