

050-200267

TOSHIBA

SERVICE MANUAL

COLOUR TELEVISION

32WH37G

AK41 Chassis

CONTENTS

| | |
|--|----------|
| Safety Precautions | 2 |
| TV Set switched off | 2 |
| Measurements | 2 |
| PERI-TV SOCKET | 2 |
| SCART 1, SCART 2 | 2 |
| INTRODUCTION | 2 |
| SWITCH-MODE POWER SUPPLY (TDA 16846) | 3 |
| IF PART (TDA 4470/72) | 3-4 |
| TUNER | 4-5 |
| SAW FILTERS | 5 |
| DIGITAL TV SOUND PROCESSING (MSP 3410D) | 5-6 |
| DOLBY PRO LOGIC PROCESSOR IC (DPL 3519A) | 6-7 |
| HEADPHONE OUTPUT (TDA 1308) | 7 |
| VIDEO OUTPUT (TDA 7265) | 7-8 |
| VIDEO INPUT AND OUTPUT SOURCE SWITCHING (TEA 6415) | 8 |
| VIDEO OUTPUT AMPLIFIER STAGE (TDA 6111Q) | 8-9 |
| VERTICAL OUTPUT STAGE (TDA 9379FA) | 9 |
| TTEXT CONTROLLER (SDA 5550M) | 9-10 |
| SERIAL ACCESS 32K EEPROM (24L32-W) | 10-11 |
| EPROM (M27W401) | 11 |
| 100Hz FEATURE BOX | 11 |
| VPC32X5 (VIDEO PROESSOR) | 11 |
| CIP3250 | 12-13 |
| SDA9400 | 13-14-15 |
| DDP3310 | 15-16 |
| AK41 CHASSIS MANUAL ADJUSTMENTS PROCEDURE | 17 |
| PRELIMINARY | 17 |
| SYSTEM VOLTAGE AJUSTMENT | 17 |
| AFC ADJUSTMENT | 17 |
| FOCUS ADJUSTMENT | 17 |
| SCREEN ADJUSTMENT | 17 |
| IF ADJUSTMENT FOR L'MODE | 17 |
| AK41 CHASSIS PRODUCTION MODE ADJUSTMENTS PROCEDURE | 18 |
| PRELIMINARY | 18 |
| HORIZONTAL AND VERTICAL GEOMETRY ALIGNMENTS | 18 |
| V-SHIFT | 18 |
| V-SIZE | 18 |
| H-SHIFT | 18 |
| H-SIZE | 18 |
| S-COR | 18 |
| LINRT | 18 |
| ANGLE | 18 |
| BOW | 18 |
| TRPEZ | 18 |
| PARAB | 18 |
| U.COR | 19 |
| L.COR | 19 |
| VIDEO ALIGNMENTS | 19 |
| RGn, GGn, BGn, :WHITE BALANCE ADJUSTMENT | 19 |
| RRf, GRf, BRf | 19 |
| YDF | 19 |
| AGC | 19 |
| TLAN | 19 |
| APS | 19 |
| T_T | 19 |
| T_P | 19 |
| EXT3 | 19 |
| CLT | 19 |
| SERVICE ALIGNMENTS | 20 |
| IMPORTANT | 20 |
| ADJUSTMENTS GROUOP | 20 |
| OPTIONS GROUP | 20 |
| SYSTEM GROUP | 20 |
| GENERAL BLOCK DIAGRAM OF CHASSIS AK41 | 21 |
| CIRCUIT DIAGRAMS | 22 |

DO NOT CHANGE ANY MODULE UNLESS THE SET IS SWITCH OFF

The mains supply side of the switch mode power supply transformer is live.

Use an isolating transformer.

The receivers fulfill completely the safety requirements.

Safety precautions:

Servicing of this TV should only be carried out by a qualified person.

- Components marked with the warning symbol on the circuit diagram are critical for safety and must only be replaced with an identical component.

- Power resistor and fusible resistors must be mounted in an identical manner to the original component.

- When servicing this TV, check that the EHT does not exceed 26kV.

TV Set switched off:

Make short-circuit between HV-CRT clip and CRT ground layer.

Short C804 (150mF) before changing IC802 or other components in primary side of SMPS.

Measurements:

Voltage readings and oscilloscope traces are measured under following conditions.

Antenna signal 60dB from colourbar generator. (100% white, 75% colour saturation)

Brightness, contrast, colour set for a normal picture.

Mains supply, 220VAC, 50Hz.

PERI-TV SOCKET

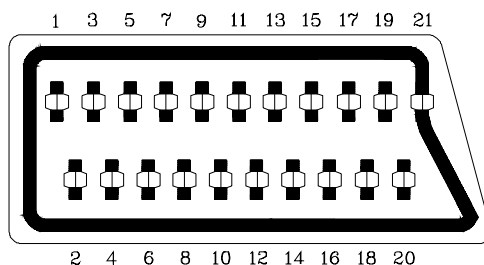

SCART 1 (SC050)

| | | |
|----|--------------------|--------------------------|
| 1 | Audio right output | 0.5Vrms / 1K |
| 2 | Audio right input | 0.5Vrms / 10K |
| 3 | Audio left output | 0.5Vrms / 1K |
| 4 | Ground AF | |
| 5 | Ground Blue | |
| 6 | Audio left input | 0.5Vrms / 10K |
| 7 | Blue input | 0.7Vpp / 75ohm |
| 8 | AV switching input | 0-12VDC / 10K |
| 9 | Ground Green | |
| 10 | - | |
| 11 | Green input | 0.7Vpp / 75ohm |
| 12 | - | |
| 13 | Ground Red | |
| 14 | Ground Blanking | |
| 15 | Red input | 0.7Vpp / 75ohm |
| 16 | Blanking input | 0-0.4VDC, 1-3VDC / 75ohm |
| 17 | Ground CVS output | |
| 18 | Ground CVS input | |
| 19 | CVS output | 1Vpp / 75ohm |
| 20 | CVS input | 1Vpp / 75ohm |
| 21 | Ground | |

SCART 2 (SC051)

| | | |
|----|--------------------|----------------|
| 1 | Audio right output | 0.5Vrms / 1K |
| 2 | Audio right input | 0.5Vrms / 10K |
| 3 | Audio left output | 0.5Vrms / 1K |
| 4 | Ground AF | |
| 5 | Ground Blue | |
| 6 | Audio left input | 0.5Vrms / 10K |
| 7 | Blue input | 0.7Vpp / 75ohm |
| 8 | AV switching input | 0-12VDC / 10K |
| 9 | Ground Green | |
| 10 | - | |
| 11 | - | |
| 12 | - | |
| 13 | Ground Red | |
| 14 | Ground Blanking | |
| 15 | - | |
| 16 | - | |
| 17 | Ground CVS output | |
| 18 | Ground CVS input | |
| 19 | CVS output | 1Vpp / 75ohm |
| 20 | CVS input | 1Vpp / 75ohm |
| 21 | Ground | |

INTRODUCTION

11Ak41 is a 100Hz flicker free colour television capable of driving 28"4:3/16:9, 33"4:3 and 29"4:3 real flat picture tubes.

The chassis is capable of operation in PAL, SECAM, NTSC (playback) colour standards and multiple transmission standards as B/G, D/K, I/I', and L/L'.

Sound system output is supplying 12W (10%THD) for left, right and center outputs of 8ohm speakers, and 2 x 7W for surround outputs of 2 x 4ohm speakers, connected in series.

TV supports the level 1.5 teletext standard. It is possible to decode transmissions including high graphical data.

The chassis is equipped with one full EuroScart, ONE OTHER SCART for AV input/output, one front-AV input, one back-AV output, one headphone output, one SVHS input (via SCART and SVHS connector), one VGA input, two external speaker outputs (left and right), one centre speaker output, and one surround speaker output for two speakers in series.

SWITCH-MODE POWER SUPPLY (TDA16846)

A SMPS transformer controlled by the IC TDA16846, which is designed for driving, controlling, and protecting switching transistor, provides the DC voltages required at various parts of the chassis. SMPS generates the necessary 3.3V and 2.5V supplies for the micro-controller, 130V supply for the FBT, +/-16V supply for the audio amplifier, which are active in stand-by and 8V, 12V and 5V supplies for other different parts of the chassis.

When the TV is switched on, a reference voltage is provided to TDA16846 and the start-up operation occurs, then TV enters into the stand-by position.

Two optocouplers are used to control the regulation of line voltage and stand-by power consumption. There are two regulation circuits, one in primary side and one in secondary side. The primary regulation circuit provides a control voltage to pin3 of the IC. Secondary regulation circuit produces a control voltage according to the changes in 130V DC voltage, via an optocoupler (SFH617A) to pin4 of the IC.

During the switch on period of the transistor, energy is stored in the transformer. During the switch off period energy is fed to the load via secondary winding. By varying switch-on time of the power transistor, it controls each portion of energy transferred to the second side such that the output voltage remains nearly independent of load variations. At the same time, the supply voltages 12V, 8V, 5V are stabilised by the series regulators.

Features:

- Line Current Consumption with PFC
- Continuous Frequency Reduction with Decreasing Load
- Stable and Adjustable Stand-by Frequency
- Very Low Start-up Current
- Soft-Start for Quiet Start-up
- Adjustable and Voltage Dependent Ringing Suppression Time
- Synchronization and Fixed Frequency Facility
- Over- and Under-voltage Lockout
- Switch Off at Mains Under-voltage
- Mains Voltage Dependent Fold Back Point Correction
- Low Power Consumption
- Free usable Fault Comparators

Pinning:

1. OTC Off Time Circuit
2. PCS Primary Current Simulation
3. RZI Regulation and Zero Crossing Input
4. SRC Soft-Start and Regulation Capacitor
5. OCI Opto Coupler Input
6. FC2 Fault Comparator 2
7. SYN Synchronization Input
8. N. C. Not Connected
9. REF Reference Voltage and Current
10. FC1 Fault Comparator 1
11. PVC Primary Voltage Check
12. GND Ground
13. OUT Output
14. VCC Supply Voltage

IF PART (TDA4470/72)

The TDA44XX is an integrated bipolar circuit for multistandard video/sound IF (VIF/SIF) signal processing in TV/VCR and multimedia applications. The circuit processes all TV video IF signals with negative modulation (e.g., B/G standard), positive modulation (e.g., L standard) and the AM, FM/NICAM sound IF signals. Active carrier generation by FPLL (frequency phase-locked loop) is the principle for true synchronous demodulation. VCO circuit is operating on picture carrier frequency, the VCO frequency is switchable for L'-mode. AFC without external reference circuit is alignment-free and polarity of the AFC curve is switchable. VIF-AGC for negative modulated signals operates on peak sync detection principle and for positive modulation on peak white / black level detection principle. Tuner AGC is adjustable with determining take over point. It has alignment-free quasi-parallel sound (QPS) mixer for FM/NICAM sound IF signals. Intercarrier output sound is gain controlled (necessary for digital sound processing). AM-demodulator is completely alignment-free with gain controlled AF output. Operation of the AM demodulator and QPS mixer (for NICAM-L stereo sound is parallel. TDA4472 is used for negative modulation and TDA4470 is used for both negative and positive modulation.

Features:

- 5V supply voltage; low power consumption
- Active carrier generation by FPLL principle (frequency-phase-locked-loop) for true synchronous demodulation
- Very linear video demodulation, good pulse response and excellent intermodulation figures
- VCO circuit is operating on picture carrier frequency, the VCO frequency is switchable for the L' mode
- Alignment-free AFC without external reference circuit, polarity of the AFC curve is switchable
- VIF-AGC for negative modulated signals (peak sync detection) and for positive modulation (peak white/black level detector).
- Tuner AGC with adjustable take over point
- Alignment-free quasi parallel sound (QPS) mixer for FM/NICAM sound IF signals
- Intercarrier output signal is gain controlled (necessary for digital sound processing)
- Complete alignment-free AM demodulator with gain controlled AF output
- Separate SIF-AGC with average detection
- Two independent SIF inputs
- Parallel operation of the AM demodulator and QPS mixer (for NICAM-L stereo sound)
- Package and relevant pinning is compatible with the single standard version TDA 4472; simplifies the design of an universal IF module

Pinning:

- | | | |
|----------------------------------|--------------------------|--|
| 1. Input sensitivity, RMS value | : 80mVrms | |
| 2. Input sensitivity, RMS value | : 80mVrms | |
| 3. SIF Input selector switch | : 2.0 V | |
| 4. Ground | | |
| 5. IF gain control range | : 65dB | |
| 6. Input sensitivity, RMS value | : 80mVrms | |
| 7. Input sensitivity, RMS value | : 80mVrms | |
| 8. IF gain control range | : 65dB | |
| 9. Ground | | |
| 10. Available tuner-AGC current | : 2mA | |
| 11. Available tuner-AGC current | : Min : 0.3V Max : 13.5V | |
| 12. Video output | : Min : 1.8V Max : 2.2V | |
| 13. Standard switch | : Min : 0V Max : 0.8V | |
| 14. L' switch | : Min : 0V Max : 3.0V | |
| 15. IF gain control range | : 65dB | |
| 16. Ground | | |
| 17. Internal reference voltage | | |
| 18. FPLL and VCO | : Min : 1mA Max : 4mA | |
| 19. AFC switch | : Min : 0V Max : 0.8V | |
| 20. FPLL and VCO | : Min : 1mA Max : 4mA | |
| 21. FPLL and VCO | : Min : 1mA Max : 4mA | |
| 22. AFC output | : 0.7 mA/kHz | |
| 23. DC supply | : Min : 4.5V Max : 9.0V | |
| 24. DC output voltage | : 2V | |
| 25. AF output-AM | : 2.2V | |
| 26. FPLL and VCO | : Min : 1mA Max : 4mA | |
| 27. Input sensitivity, RMS value | : 80mVrms | |
| 28. Input sensitivity, RMS value | : 80mVrms | |

TUNER

The hardware and software of the TV is suitable for tuners, supplied by different companies, which are selected from the Service Menu. These tuners can be combined VHF, UHF tuners suitable for CCIR systems B/G, H, L, L', I/I', and D/K. The tuning is available through the digitally controlled I²C bus (PLL). Below you will find info on one of the Tuners in use.

General description of UV1316:

The UV1316 tuner belongs to the UV 1300 family of tuners, which are designed to meet a wide range of applications. It is a combined VHF, UHF tuner suitable for CCIR systems B/G, H, L, L', I and I'. The low IF output impedance has been designed for direct drive of a wide variety of SAW filters with sufficient suppression of triple transient.

Features of UV1316:

- Member of the UV1300 family small sized UHF/VHF tuners
- Systems CCIR: B/G, H, L, L', I and I'; OIRT: D/K
- Digitally controlled (PLL) tuning via I²C-bus
- Off-air channels, S-cable channels and Hyperband
- World standardised mechanical dimensions and world standard pinning
- Compact size
- Complies to "CENELEC EN55020" and "EN55013"

Pinning:

1. Gain control voltage (AGC) : 4.0V, Max:4.5V
2. Tuning voltage
3. I²C-bus address select : Max:5.5V
4. I²C-bus serial clock : Min:-0.3V, Max:5.5V
5. I²C-bus serial data : Min:-0.3V, Max:5.5V
6. Not connected
7. PLL supply voltage : 5.0V, Min:4.75V, Max:5.5V
8. ADC input
9. Tuner supply voltage : 33V, Min:30V, Max:35V
10. Symmetrical IF output 1
11. Symmetrical IF output 2

SAW FILTERS

K9453: Two channels switchable sound IF saw filter of BG, DK, I, L systems for input channel 2 and of L' system for input channel 1.

K3953: Two channel switchable video IF saw filter of BG, DK, I, L systems for input channel 2 and of L' system for input channel 1.

J3950: Video IF saw filter for I system

DIGITAL TV SOUND PROCESSING

MSP3410D

The MSP3410D is an I²C controlled single-chip multistandard sound processor for applications in analog and digital TV sets. The full TV sound processing, starting with analog sound IF signal-in, down to processed analog AF-out is performed in a single-chip covering all European TV-standards. It is designed to simultaneously perform digital demodulation and decoding of NICAM-coded TV stereo sound, as well as demodulation of FM-mono TV sound and two FM systems according to the German or Korean terrestrial specs. It is also possible to do AM-demodulation according to the SECAM system. There is AGC for analog inputs: 0.14 - 3Vpp. All demodulation and filtering is performed on chip and is individually programmable. All digital NICAM standards (B/G, L, and I) are realised. Only one crystal clock (18.432Mhz) is necessary. External capacitors at each crystal pin to ground are required. They are necessary for tuning the open-loop frequency of the internal PLL and for stabilising the frequency in closed-loop operation. The higher the capacitors, the lower the clock frequency result. The nominal free running frequency should match the centre of the tolerance range between 18.433 and 18.431Mhz as closely as possible. By means of standardised I²S interface, additional feature processors (DPL35xx, Dolby Prologic processor for this chassis) can be connected to the IC.

I²S bus interface consists of five pins:

- I²S_DA_IN1...2 for input four channels (two channels per line) per sampling cycle (32Khz).
- I²DA_OUT, for output, two channels per sampling cycle (32KHz).
- I²S_CL, for timing of the transmission of I²S serial data, 1.024Mhz.
- I²S_WS, for the word strobe line defining the left and right sample.

Features:

- 5-band graphic equalizer (as in MSP3400C)
- Enhanced spatial affect (pseudo stereo / base-width enlargement as in MSP3400C)
- Headphone channel with balance, bass treble, loudness
- Balance for loudspeaker and headphone channels in dB units (optional)
- Additional pair of D/A converters for SCART2 out
- Improved over-sampling filters (as in MSP 3400C)
- Additional SCART input
- Full SCART in/out matrix without restrictions
- SCART volume in dB units (optional)
- Additional I²S input (as in MSP 3400C)
- New FM-identification (as in MSP 3400C)
- Demodulator short programming
- Auto-detection for terrestrial TV-sound standards
- Precise bit-error rate indication
- Automatic switch from NICAM to FM/AM or vice versa
- Improved NICAM synchronisation algorithm
- Improved carrier mute algorithm
- Improved AM-demodulation
- ADR together with DRP 3510A
- Dolby Pro Logic together with DPL 35xx A
- Reduction of necessary controlling
- Less external components
- Significant reduction of radiation

Pinning:

- | | |
|--|---|
| 1. ADR wordstrobe | 35. Analog Shield Ground 1 |
| 2. Not connected | 36. Scart input 3 in right |
| 3. ADR data output | 37. Scart input 3 in left |
| 4. I ² S 1 data input | 38. Analog Shield Ground 4 |
| 5. I ² S data output | 39. Scart input 4 in, right |
| 6. I ² S wordstrobe | 40. Scart input 4 in, left |
| 7. I ² S clock | 41. Not connected |
| 8. I ² S data | 42. Analog reference voltage high voltage part |
| 9. I ² S clock | 43. Analog ground |
| 10. Not connected | 44. Volume capacitor MAIN |
| 11. Standby (low-active) | 45. Analog power supply 8.0V |
| 12. I ² C Bus address select | 46. Volume capacitor AUX |
| 13. Digital control output 0 | 47. Scart output 1, left |
| 14. Digital control output 1 | 48. Scart output 1, right |
| 15. Not connected | 49. Reference ground 1 high voltage part |
| 16. Not connected | 50. Scart output 2, left |
| 17. Not connected | 51. Scart output 2, right |
| 18. Audio clock output | 52. Analog Shield Ground 3 |
| 19. Not connected | 53. Not connected |
| 20. Crystal oscillator | 54. Not connected |
| 21. Crystal oscillator | 55. Not connected |
| 22. Test Pin | 56. Analog output MAIN, left |
| 23. IF input 2 (if ANA_IN1+is used only, connect | 57. Analog output MAIN, right to AVSS with 50 pF capacitor) 58. |
| 24. IF common | 58. Reference ground 2 high voltage part |
| 25. IF input 1 | 59. Analog output AUX, left |
| 26. Analog power supply +5V | 60. Analog output AUX, right |
| 27. Analog ground | 61. Power-on-reset |
| 28. Mono input | 62. Not connected |
| 29. Reference voltage IF A/D converter | 63. Not connected |
| 30. Scart input 1 in, right | 64. Not connected |
| 31. Scart input 1 in, left | 65. I ² S2-data input |
| 32. Analog Shield Ground 2 | 66. Digital ground |
| 33. Scart input 2 in, right | 67. Digital power supply +5V |
| 34. Scart input 2 in, left | 68. ADR clock |

DOLBY PRO LOGIC PROCESSOR IC**DPL3519A**

The IC DPL3519A processor family is designed to decode Dolby encoded surround sound. The IC integrate the complete Dolby Surround Pro Logic decoding on chip without any necessary external circuitry. It designed as a coprocessor of the MSP34xx family.

It gets digitised sound from the audio processor IC MSP3410D for both C (centre) and S (surround) channels, and for both L (left) and R (right) channels. The analog L and R outputs are supplied by MSP3410D, while the analog S and C outputs are supplied by the DPL33519A.

Two I²S busses obtain synchronisation between the MSP and DPL :

I²S_CL; for timing of the transmission of I²S serial data 1.024Mhz and I²S_WS; The word strobe line defining the left and right sample at 32Khz. The IC is also I²C bus controlled to select the sound feature (Stereo, 3D-Phonic and Dolby Pro Logic).

Pinning:

- | | |
|---|------------------------------|
| 1. Not connected | 16. Not connected |
| 2. Not connected | 17. Not connected |
| 3. Not connected | 18. Audio clock output |
| 4. I ² S1 data input | 19. Digital control input |
| 5. I ² S1 data output | 20. Crystal oscillator |
| 6. I ² S wordstrobe | 21. Crystal oscillator |
| 7. I ² S clock | 22. Test pin |
| 8. I ² C data | 23. Not connected |
| 9. I ² C clock | 24. Not connected |
| 10. Not connected | 25. Not connected |
| 11. Standby (low-active) | 26. Analog power supply +5 V |
| 12. I ² C-Bus address select | 27. Analog ground |
| 13. Digital control IO 0 | 28. Mono input |
| 14. Digital control IO 1 | 29. Reference voltage |
| 15. Not connected | 30. Scart input 1 in, right |

- | | |
|--|--|
| 31. Scart input 1 in, left | 50. Scart output 2, left |
| 32. Analog Shield Ground 1 | 51. Scart output 2, right |
| 33. Scart input 2 in, right | 52. Analog Shield Ground 3 |
| 34. Scart input 2 in, left | 53. Not connected |
| 35. Analog Shield Ground 2 | 54. Not connected |
| 36. Scart input 3 in, right | 55. Not connected |
| 37. Scart input 3 in, left | 56. Analog output Channel 1, left |
| 38. Analog Shield Ground 4 | 57. Analog output Channel 1, right |
| 39. Not connected | 58. Reference ground 2 high voltage part |
| 40. Not connected | 59. Analog output Channel 2, left |
| 41. Not connected | 60. Analog output Channel 2, right |
| 42. Analog reference voltage high voltage part | 61. Power-on-reset |
| 43. Analog ground | 62. Not connected |
| 44. Volume capacitor Channel1 | 63. Not connected |
| 45. Analog power supply 8.0 V | 64. I2S2-data output |
| 46. Volume capacitor Channel 2 | 65. I2S2-data input |
| 47. Scart output 1, left | 66. Digital ground |
| 48. Scart output 1, right | 67. Digital power supply +5 V |
| 49. Reference ground 1 high voltage part | 68. Not connected |

HEADPHONE OUTPUT

TDA1308

The TDA1308 is an integrated class AB stereo headphone driver. It gets its input from two analog audio outputs (DACA_L and DACA_R) of MSP3410D. The gain of the output is adjustable by the feedback resistor between the inputs and outputs.

Features:

- Wide temperature range
- No switch ON/OFF clicks
- Excellent power supply ripple rejection
- Low power consumption
- Short-circuit resistant
- High performance
 - high signal-to-noise ratio
 - high slew rate
 - low distortion
- Large output voltage swing

Pinning:

- | | |
|-----------------------------|------------------------------|
| 1. Output A (Voltage swing) | : Min : 0.75V, Max : 4.25V |
| 2. Inverting input A | : Vo(clip) : Min : 1400mVrms |
| 3. Non-inverting input A | : 2.5V |
| 4. Ground | |
| 5. Non-inverting input B | : 2.5V |
| 6. Inverting input B | : Vo(clip) : Min : 1400mVrms |
| 7. Output B (Voltage swing) | : Min : 0.75V, Max : 4.25V |
| 8. Positive supply | : 5V, Min : 3.0V, Max : 7.0V |

AUDIO OUTPUT

TDA7265

The TDA7265 is a 25W+25W stereo sound amplifier with mute/stand-by facility. STPA control signal coming from microcontroller (when it is at high level) activates the mute function. IC is muted when mute port is at low level. Two stereo audio signals coming from audio module is injected to the inputs of the IC and a power of 12W_{rms} (10%) is obtained. An external pop-noise circuitry pulls AF inputs of the IC in order to eliminate pop noise when TV is turned on or off via mains supply connection. It is possible to adjust the gain of the amplifiers by feedback external resistors.

Features:

- Wide supply voltage range (up to 50V ABS Max.)
- Split supply
- High output power: 25+25 W @ TDA = 10%, RL = 8ohm, VS = ±20V
- No pop at turn-on / off
- Mute (pop free)
- Stand-By feature (low IQ)
- Few external components
- Thermal overload protection
- Adjustable gain via an external resistor

Pinning:

1. Output (1)
2. +Vs
3. Output (2)
4. Mute / St-By
5. -Vs
6. Input (2)
7. Ground
8. Input (1)

VIDEO INPUT AND OUTPUT SOURCE SWITCHING**TEA6415C**

Video switching is performed by the I2C controlled IC TEA6415C with a gain of 0dB. Inputs to the video switch are IF_CVBS, three SCART video signals, front-AV video signal, SVHS luma signal, and one of SC1_R or SVHS_C. Outputs of the video switch are three SCART video signals (SC1_OUT_V and SC3_OUT_V are the same), one video output for the PIP module, Chroma signal (C), and luma (Y) or CVBS signal.

Features:

- 20 MHz Bandwidth
- Cascadable with another TEA6415C (Internal address can be changed by pin 7 voltage)
- 8 inputs (CVBS, RGB, Mac, CHROMA, ...)
- 6 Outputs
- Possibility of MAC or chroma signal for each input by switching-off the clamp with an external resistor bridge
- Bus controlled
- 6.5dB gain between any input and output
- -55dB crosstalk at 5MHz
- Fully ESD protected

Pinning:

- | | | | | |
|------------|---------------|-----------------------|------------|------------|
| 1. Input | : Max | : 2Vpp, Input Current | : 1mA, Max | : 3mA |
| 2. Data | : Low level | : -0.3V | Max | : 1.5V, |
| | High level | : 3.0V | Max | : Vcc+0.5V |
| 3. Input | : Max | : 2Vpp, Input Current | : 1mA, Max | : 3mA |
| 4. Clock | : Low level | : -0.3V | Max | : 1.5V, |
| | High level | : 3.0V | Max | : Vcc+0.5V |
| 5. Input | : Max | : 2Vpp, Input Current | : 1mA, Max | : 3mA |
| 6. Input | : Max | : 2Vpp, Input Current | : 1mA, Max | : 3mA |
| 7. Prog | | | | |
| 8. Input | : Max | : 2Vpp, Input Current | : 1mA, Max | : 3mA |
| 9. Vcc | : 12V | | | |
| 10. Input | : Max | : 2Vpp, Input Current | : 1mA, Max | : 3mA |
| 11. Input | : Max | : 2Vpp, Input Current | : 1mA, Max | : 3mA |
| 12. Ground | | | | |
| 13. Output | : 5.5Vpp, Min | : 4.5Vpp | | |
| 14. Output | : 5.5Vpp, Min | : 4.5Vpp | | |
| 15. Output | : 5.5Vpp, Min | : 4.5Vpp | | |
| 16. Output | : 5.5Vpp, Min | : 4.5Vpp | | |
| 17. Output | : 5.5Vpp, Min | : 4.5Vpp | | |
| 18. Output | : 5.5Vpp, Min | : 4.5Vpp | | |
| 19. Ground | | | | |
| 20. Input | : Max | : 2Vpp, Input Current | : 1mA, Max | : 3mA |

VIDEO OUTPUT AMPLIFIER STAGE**TDA6111Q**

The TDA6111Q is a video output amplifier with 16Mhz bandwidth. It has a high slew rate. Automatic black-current stabilisation is possible by black-current measurement output. It has two cathode outputs: one for DC currents and one for transient currents. A feedback output is separated from the cathode outputs. An internal protection exists against positive appearing cathode-ray-tube flashover discharges with ESD protection.

Features:

- High bandwidth and slew rate
- Black-current measurement output for Automatic Black-current Stabilisation (ABS)
- Two cathode outputs; one for DC currents, and one for transient currents
- A feedback output separated from the cathode outputs
- Internal protection against positive appearing cathode-ray Tube (CRT) flashover discharges
- ESD protection
- Simple application with a variety of colour decoders
- Differential input with a designed maximum common mode input capacitance of 3pF, a maximum differential mode input capacitance of 0.5 pF and a differential input voltage temperature drift of 50 uV/K
- Defined switch-off behaviour.

Pinning:

1. Non-inverting voltage input
2. Supply voltage LOW
3. Inverting voltage input
4. Ground, substrate
5. Black current measurement output
6. Supply voltage HIGH
7. Cathode transient voltage output
8. Cathode CD voltage output
9. Feedback voltage output

VERTICAL OUTPUT STAGE**TDA9379FA**

The IC TDA9379FA is the vertical deflection booster circuit. Two supply voltages, +12V and -12V are needed to scan the inputs VERT+ and VERT-, respectively. And a third supply voltage, +45V for the flyback limiting are needed. The vertical deflection coil is connected in series between the output and feedback to the input.

Features:

- Power Amplifier
- Thermal Protection
- Output Current up to 2.6App
- Flyback Voltage up to 90V
- External Flyback Supply

Pinning:

1. Inverting Input
2. Supply Voltage
3. Flyback Supply
4. GND or Negative Supply
5. Output
6. Output Stage Supply
7. Non-inverting Input

TVTEXT CONTROLLER**(SDA5550M)**

The SDA5550M is a single chip teletext decoder for decoding World System Teletext data as well as Video Programming System (VPS), Program Delivery Control (PDC), and Wide Screen Signalling (WSS) data used for PAL plus transmissions (Line 23). The device provides an integrated general-purpose, fully 8051-compatible Microcontroller with television specific hardware features. Microcontroller has been enhanced to provide powerful features such as memory banking, data pointers, and additional interrupts etc. The on-chip display unit for displaying Level 1.5 teletext data can also be used for customer defined on screen displays. Internal XRAM consists of up to 17 Kbytes. AK41 has the version without internal ROM. This device can support external memory up to 1Mbyte ROM and RAM. TVTEXT Controller contains a data slicer for VPS, WSS, PDC and TXT, an acceleration acquisition hardware module, a display generator for Level 1.5 TXT and powerful On screen Display capabilities based on parallel attributes, and pixel oriented characters (DRCS). The 8 bit Microcontroller operates at 360nsec cycle time (min). Controller with dedicated hardware does most of the internal TXT acquisition processing, transfer data to/from external memory interface and receives/transmits data via I²C-firmware user interface. SDA5550M is realized in 0.25 micron technology with 2.5V supply voltage and 3.3V I/O compatible.

The IC produces the following input or output control signals; AGC_CON, MODE_SW, L / L', PIP_MODS, PIP_SEL, ON/OFF (stand-by), SC1..3_IN_AV (pin 8 information from 3 SCARTs), AFC, MUTE (to mute audio output IC), I2CEN.

Features:**■ General**

- Feature selection via special function register
- Simultaneous reception of TXT, VPS, PDC and WSS (Line 23)
- Supply Voltage 2.5 and 3.3V
- P-MQFP100 Package

■ Microcontroller

- Single external 6Mhz crystal, all necessary clocks are generated internally
- CPU speed selectable via special function registers
- Normal mode 33.33 MHz CPU clock, Power Save mode 8.33MHz
- 8 bit 8051 instruction set compatible CPU
- 360 ns minimum instruction cycle

- Two 16 bit timers, Watchdog timer
- PWM unit (2 channels 14 bit, 6 channels 8 bit)
- ADC (4 channels, 8 bit), UART
- I²C interface

■ Memory

- Non-multiplexed 8-bit data and 16 (up to 20) bit address bus
- Memory banking up to 1Mbyte
- Eight 16 bit data pointer registers (DPTR)
- 256 bytes on-chip internal RAM
- 128 bytes extended stack memory
- 16 Kbytes Extended RAM for Display Memory

■ Display

- ROM character set supports all East/West European Languages
- Parallel display attributes
- Single/Double Width/Height of characters
- Variable flash rate
- Programmable screen size
- Up to 16 colours per DRCS character
- Shadowing
- Support of Progressive Scan and 100Hz
- Contrast Reduction

■ Ports

- One 8 bit I/O port with open drain output and optional I²C Bus emulation support (Port 1)
- Two 8 bit multifunction I/O ports (Port1, Port3)
- One 4 bit port operating as digital or analog inputs for ADC (Port 2)
- One 2 bit I/O port with secondary functions (P4.2, 4.3, 4.7)
- One 4 bit I/O port with secondary functions (P4.0, 4.1, 4.4)

SERIAL ACCESS 32K EEPROM (24LC32-W)

It is the 32Kbit electrically erasable programmable memory. The memory is compatible with the I2C standard, two wire serial interface, which uses a bi-directional data bus and serial clock.

Features:

- Single supply with 3.3V (operation down to 2.5V)
- Compatible with I2C extended addressing
- 2-wire I2C serial interface supports 100kHz protocol
- Self-timed ERASE and WRITE cycles
- Power on/off data protection circuitry
- Hardware write protect
- 1,000,000 Erase/Write cycles guaranteed
- 32-byte page or byte writes modes available
- Schmidt trigger filtered inputs for noise suppression
- Output slope control to eliminate ground bounce
- 2 ms typical write cycle time, byte or page
- Electrostatic discharge protection > 4000V
- Data retention > 200 years
- 8-pin PDIP and SOIC packages

Pinning:

1. E0 User Configurable Chip Select
2. E1 User Configurable Chip Select
3. E2 User Configurable Chip Select
4. Vss Ground
5. SDA Serial Address/Data I/O
6. SCL Serial Clock
7. WC Write Protect Input
8. Vcc +2.5V to 6.0V Power Supply

EPROM (M27W401)

The M27W401 is a low voltage 4Mbit EPROM (UV erasable). It is ideally suited for micro processor systems requiring large data or program storage and is organised as 522,288 by 8 bits. The M27W401 operates in the read mode with a supply voltage as low as 2.7V at -40 to 85°C temperature range.

Features:

- Organisation 512K x 8
- Single 3.3V power supply
- Operationally Compatible with Existing Megabit EPROMs
- Industry Standard 32-pin Dual-in-line Package
- All inputs/Outputs Fully TTL Compatible
- 8-Bit Output for Use in Microprocessor-Based Systems
- Power Saving CMOS Technology
- 3-State Output Buffers
- 400 mV Minimum DC Noise Immunity with Standard TTL Loads
- Latch up immunity of 250mA on all input and output pins
- No pull-up resistors required
- Low power dissipation

100Hz FEATURE BOX

VPC3215, CIP3250, SDA9400, DDP3310

The feature box consists of four I²C controlled ICs:

Video Processor VPC3215
Component Interface Processor CIP3250
Digital Image Processor SDA9400
Digital Deflection Processor DDP3310

The input supplies to the feature box are +12V, +5V. The ICs do also need a supply of 3.3V, which is regulated by IC4 LM314.

Besides the composite video in normal operation and luma/chroma inputs in the SVHS applications, there are also R-G-B-FB inputs from the PIP module.

OSD R-G-B-FB inputs from the Megatext IC or from the controller in the case of TV-text option. While the 50Hz sync signals for PIP are supplied by the VPC3215, the 100Hz sync signals for OSD are supplied by the DDP3310.

Control signals for HV stage such as VertQ, Vert, HDrive, EW (East-West) and SVM (Scan Velocity Modulation) are produced by this module. VProt and HProt input signals are used for protection. There are also a flyback sample signal from HV stage and the sense signal from the CRT board.

The feature box also supports the VGA mode.

VPC32X5 (Video Processor)

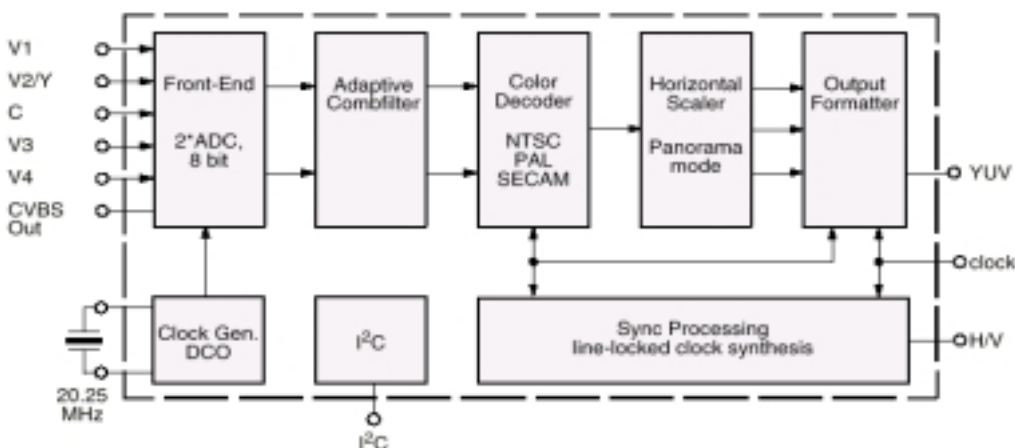

Figure 1

As seen in figure 1 all the processings in VPC are digital. This IC has four composite, one SVHS input, and one composite output which is used for teletext. In AK28 the main video input is Vin2, which is also used for luma input in SVHS applications.

After switching the inputs the signals are converted to digital via two 8 bit ADCs. And these digital data are processed to produce the 4:2:2 formatted digital YUV signals. The main features are, multi-standard color decoding including all sub-standards, multi-standard sync processing, adaptive 4H comb filter, linear horizontal scaling, as well as nonlinear horizontal scaling (panorama vision.) It provides 50Hz vertical and 15625Hz horizontal sync signals for the PIP module.

Features:

- all-digital video processing
- high-performance adaptive 4H comb filter Y/C separator with adjustable vertical peaking
- multi-standard color decoder PAL/NTSC/SECAM including all substandards
- 4 composite, 1 S-VHS input, 1 composite output
- integrated high-quality A/D converters and associated clamp and AGC circuits
- multi-standard sync processing
- linear horizontal scaling (0.25 ... 4), as well as non-linear horizontal scaling 'panorama vision'
- PAL+ preprocessing (VPC 3215)
- line-locked clock, data and sync output (VPC 3215)
- display/deflection control (VPC 3205)
- submicron CMOS technology
- I²C-Bus Interface
- one 20.25 MHz crystal, few external components
- 68-pin PLCC package

Pinning:

| | | | |
|----------|-----------------------------|----------|----------------------------------|
| 1 | Ground | 35. | Ground |
| 2 | Ground | 36. | Supply Voltage |
| 3 | 5 MHz Clock Out | 38...47. | Picture Bus Chroma |
| 4 | Standby Supply Volt | 48...50. | Picture Bus Priority |
| 5 | Analog Crystal Out | 51. | Ground |
| 6 | Analog Crystal In | 52. | VGA Input |
| 7 | Ground | 53. | Front-End/ Back-End Data |
| 9 | Ground | 54. | Reset Input, Active Low |
| 10 | Interlace Out | 55. | I ² C Bus Data |
| 12 | Vertical Sync Pulse | 56. | I ² C Bus Clock |
| 13 | Front Sync Pulse | 57. | Test Pin, connect to GND |
| 14 | Main Sync/Horz Sync Pulse | 58. | Video 4 Analog Input |
| 15 | Helper Line Output | 59. | Ground |
| 16. | Horz Clamp Pulse | 60. | Video 3 Analog Input |
| 17. | Active Video Out | 61. | Video 2 Analog Input |
| 18. | Double Output Clock | 62. | Video 1 Analog Input |
| 19. | Output Clock | 63. | Chroma/ Video 4 Analog Input |
| 20...29. | Picture Bus Luma | 64. | Analog Video Output |
| 26. | Ground | 65. | Analog Shield GND F |
| 27. | Not Connected | 66. | Supply Voltage, Analog Front-End |
| 30. | Main Clock Output 20.25 MHz | 67. | Signal Ground for Analog Input |
| 31. | Supply Volt | 68. | Reference Voltage Top, Analog |
| 34. | Ground | | |

CIP3250:

The IC is used to interface the analog input, which is output from the PIP module (SCART RGB or PIP RGB). As can be seen from the block diagram, there is a CT-BR-SAT block, which is used for luma contrast, brightness, hue, and color saturation correction. The soft mixer is controlled by the fast blank signal.

Features:

- analog input for RGB or YUV and Fast Blank
- triple 8 bit analog to digital converters for RGB/YUV with internal programmable clamping
- single 6 bit analog to digital converter for Fast Blank signal
- digital matrix RGB % YUV (Y, B-Y, R-Y)
- luma contrast and brightness correction for signals from analog input
- color saturation and hue correction for signals from analog input
- digital input for DIGIT 2000 or DIGIT 3000 formats
- digital interpolation to 4:4:4 format
- high quality soft mixer controlled by Fast Blank signal
- programmable delays to match digital YUVin and ana-log RGB/YUV
- variable low pass filters for YUV output
- digital output in DIGIT 2000 and DIGIT 3000 formats, as well as RGB 4:4:4
- I²C bus interface
- clock frequency 13.5... 20.25 MHz

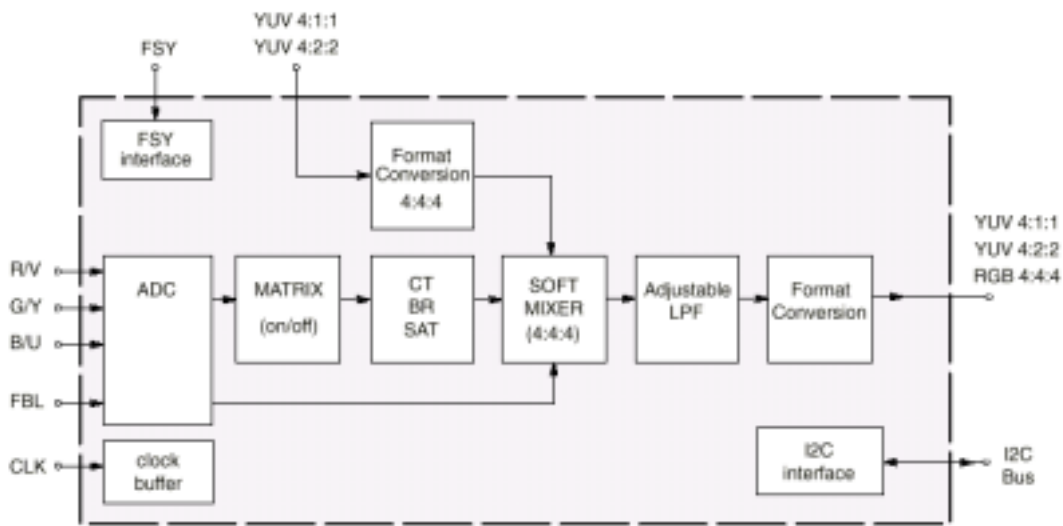

Pinning:

- | | |
|---|------------------------------------|
| 1. Standby connect to ground | 54. Main Clock Input |
| 2...9. Blue Output | 55. Reset Input |
| 10...17. Green/Luma Output | 56. In Test Mode connect to ground |
| 18. Pad Ground | 57. Analog Supply Voltage +5 V |
| 19. Pad Supply Voltage +5 V/+3.3 V | 58. Analog Ground |
| 20...27. Red/Chroma Output | 59. Reference External Capacitor |
| 28. Active Video Output | 60. Substrate connect to ground |
| 29. Active Video Input | 61. Fast Blank Input |
| 30. Front Sync Input | 62. Ground Fast Blank |
| 31. I ² C Clock Input/Output | 63. Blue/U Input |
| 32. I ² C Data Input/Output | 64. Ground Blue/U |
| 33...35. Picture Bus Priority | 65. Green/Luma Input |
| 36...43. Chroma Input | 66. Ground Green/Luma |
| 44...51. Luma Input | 67. Red/V Input |
| 52. Digital Ground | 68. Ground Red/V |
| 53. Digital Supply Voltage +5 V | |

SDA9400:

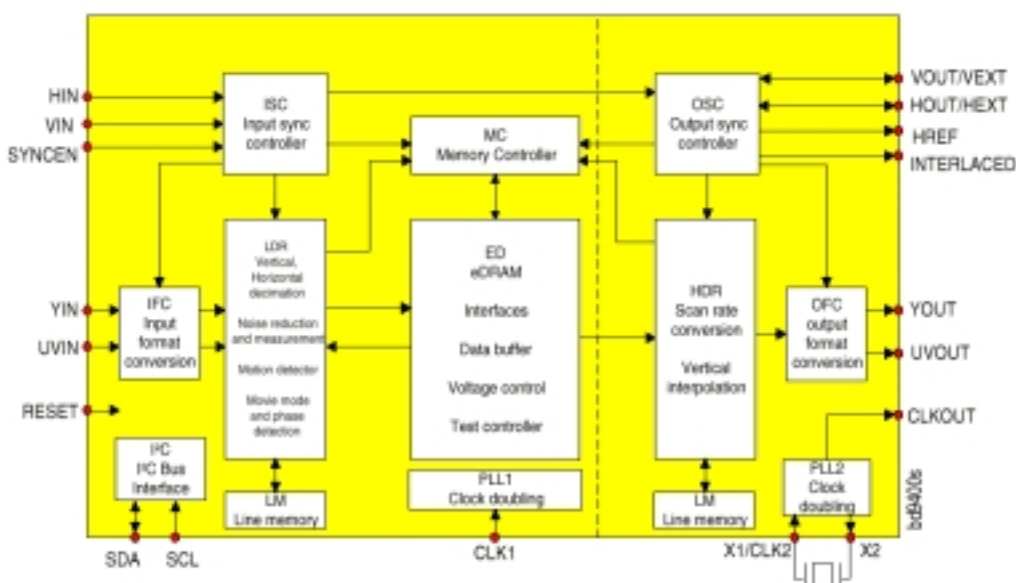

SDA9400 converts the scan rate from 50/60 Hz to 100/120 Hz

Features:

- **Two input data formats**
 - 4:2:2 luminance and chrominance parallel (2 x 8 wires)
 - ITU-R 656 data format (8 wires)
- **Two different representations of input chrominance data**
 - 2's complement code
 - Positive dual code
- **Flexible input sync controller**
- **Flexible compression of the input signal**
 - Digital vertical compression of the input signal (1.0, 1.25, 1.5, 1.75, 2.0, 3.0, 4.0)
 - Digital horizontal compression of the input signal (1.0, 2.0, 4.0)
- **Noise reduction**
 - Motion adaptive spatial and temporal noise reduction (3D-NR)
 - Temporal noise reduction for luminance frame based or field based
 - Temporal noise reduction for chrominance field based
 - Separate motion detectors for luminance and chrominance
 - Flexible programming of the temporal noise reduction parameters
 - Automatic measurement of the noise level (5 bit value, readable by I²C bus)
- **3-D motion detection**
 - High performance motion detector for scan rate conversion
 - Global motion detection flag (readable by I²C bus)
 - Movie mode and phase detector (readable by I²C bus)
- **TV mode detection by counting line numbers (PAL, NTSC, readable by I²C bus)**
- **Embedded memory**
 - 5 Mbit embedded DRAM core for field memories
 - 192 kbit embedded DRAM core for line memories
- **Flexible clock and synchronization concept**
 - Decoupling of the input and output clock system possible
- **Scan rate conversion**
 - Motion adaptive 100/120 Hz interlaced scan conversion
 - Motion adaptive 50/60 Hz progressive scan conversion
 - Simple static interlaced and progressive conversion modes for 100/120 Hz interlaced or 50/60 Hz progressive scan conversion : e.g. ABAB, AABB, AA*B*B, AAAA, BBBB, AB, AA*
 - Simple progressive scan conversion with joint lines:
 - 50 Hz -> 60, 70, 75 Hz progressive
 - 60 Hz -> 70, 75 Hz progressive
 - Large area and line flicker reduction
- **Flexible digital vertical expansion of the output signal (1.0, ... [1/32] ... , 2.0)**
- **Flexible output sync controller**
 - Flexible positioning of the output signal
 - Flexible programming of the output sync raster
 - External synchronization by backend IC possible
(e.g. split screen for one TV channel with joint lines and one PC VGA channel)
- **Signal manipulations**
 - Insertion of coloured background
 - Vertical and/or horizontal windowing with four different speed factors
 - Flash generation (for supervising applications, motion flag readable by I²C bus)
 - Still frame or field
 - Support of split screen applications
 - Multiple picture display - Tuner scan (4 and 16 times for 4:3, 12 times for 16:9 tubes)
 - Support of multi picture display with PIP or front-end processor with integrated scaler
(e.g. 9 times display of PIP pictures, picture tracking, random pictures, still-in-moving picture, moving-in-still picture)
- **I²C-bus control (400 kHz)**
- **3.3 V ± 5% supply voltage**

Pinning:

| | | | |
|---------------------|--------------------------|-----------------|----------------------------------|
| 2,8,24,42,55 | Supply volt (VSS=0V) | 54. | System clock 1 |
| 9,25,41,56 | Supply volt (VDD=3.3V) | 17,...,10 | Data output UV |
| 36,52,58 | Supply volt (VSS=0V) | 7,...,3;1;64;63 | Data output Y |
| 35,51,53,57,59 | Supply volt (VDD=3.3V) | 62 | Horz active video out |
| 43,...,50 | Data input Y | 61 | V-Sync out / Ext V-Sync |
| 31,...,34;37,...,40 | Data input UV | 60 | H-Sync out / Ext H-Sync |
| 30 | System reset. | 18 | Interlace signal vert deflection |
| 23 | H-Sync input | 28 | Crystal conn / System clock 2 |
| 22 | V-Sync input | 27 | Crystal connection |
| 29 | Sync enable input | 26 | Clock output |
| 21 | I2C-Bus data line | 19 | Test input |
| 20 | I2C-Bus clock line | | |

DDP3310:

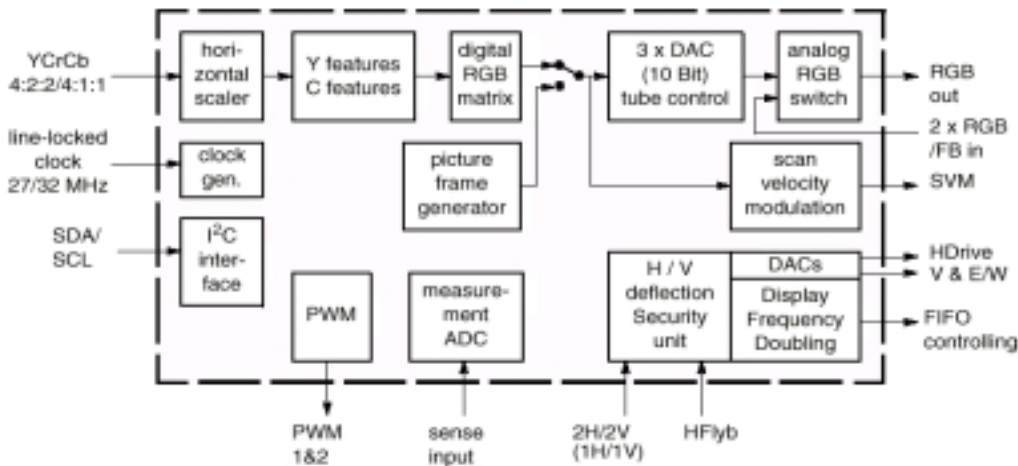

It is the display and deflection processor. All the horizontal and vertical stages are driven by this IC. The last controls such as contrast, brightness and saturation of the actual video signal, OSD and VGA are accomplished by the blocks in DDP. Tube measurement and SVM controls are also managed by this IC.

Features:

Video processing

- linear horizontal scaling (0.25 ... 4)
- non-linear horizontal scaling “panoramavision”
- dynamic peaking
- soft limiter (gamma correction)
- color transient improvement
- programmable RGB matrix
- picture frame generator
- two analog RGB/Fast-Blank inputs

Deflection processing

- scan velocity modulation output
- high-performance H/V deflection
- EHT compensation for vertical / East/West
- soft start/stop of H-Drive
- vertical angle and bow
- differential vertical output
- vertical zoom via deflection
- horizontal and vertical protection circuit
- adjustable horizontal frequency for VGA/SVGA display

Miscellaneous

- selectable 4:1:1/ 4:2:2 YC r C b input
- selectable 27/ 32-MHz line-locked clock input
- crystal oscillator for horizontal protection
- automatic picture tube adjustment (cutoff, white-drive)
- single 5-V power supply

- hardware for simple 50/60-Hz to 100/ 120-Hz con-version (display frequency doubling)
- two I²C-controlled PWM outputs
- beam current limiter

Pinning:

- | | |
|------------------------------------|---|
| 1. Supply Voltage | 28. Sup Volt, Analog Back-end |
| 2. Gnd, Output Pin Driver | 29. VRD/BCS DAC Ref, Beam Current Safety |
| 3. Additional VSYNC input | 30. Fast-Blank1 Input |
| 4. Read counter Reset | 31. Analog Red1 Input |
| 5. FIFO Read Enable | 32. Analog Green1 Input |
| 6. FIFO Write Enable | 33. Analog Blue1 Input |
| 7. FIFO Write counter Reset | 34. Fast-Blank2 Input |
| 8. Horz. Drive Output | 35. Analog Red2 Input |
| 9. Horz. Flyback Input | 36. Analog Green2 Input |
| 10. Safety Input | 37. Analog Blue2 Input |
| 11. Vertical Protection Input | 38. Test Pin |
| 12. Select of H-Drv Freq. Range | 39. Reset Input, active low |
| 13. Clock Sel 40.5 or 27/32MHz | 40. PWM out |
| 14. Clock select 27/32 MHz | 41. PWM out |
| 15. Range Switch2, Measure ADC | 42. Half-Contrast |
| 16. Range Switch1, Measure ADC | 43...50. Picture Bus Chroma |
| 17. Sense ADC Input | 51. Supply Volt, Digital Circuitry |
| 18. Ground, MADC Input | 52. Ground, Digital Circuitry |
| 19. Differential Vert Sawtooth Out | 53. Sys. Clock Input(27/32/40.5MHz) |
| 20. Differential Vert Sawtooth Out | 54...61. Y0 Picture Bus Luma |
| 21. E/W Output | 62. Single LLC Input(13.5/16MHz) |
| 22. Reference Input for RGB DACs | 63. Horizontal Sync Input |
| 23. Scan Velocity Modulation | 64. Vertical Sync Input |
| 24. Analog Output Red | 65. Analog Crystal Out (5-MHz Security Clock) |
| 25. Analog Output Green | 66. Analog Crystal In (5-MHz Security Clock) |
| 26. Analog Output Blue | 67. I ² C-Bus Data |
| 27. Ground, Analog Back-end | 68. I ² C-Bus Clock |

AK41 CHASSIS MANUAL ADJUSTMENTS PROCEDURE

A) PRELIMINARY

Before starting with the alignment procedure, make sure that all the potentiometers on the chassis and also screen and focus pots are in the medium position.

B) SYSTEM VOLTAGE ADJUSTMENT

- Inputs*
- AC power (220V 50 Hz).
 - PAL B/G test pattern via RF
(PAL I test pattern for PAL I TV's, SECAM D/K pattern, SECAM L/L 'K' TV's).
- Outputs*
- Digital voltmeter to anode of D110.
- Display*
- System voltage
- Action*
- Apply power. Check that The stand-by led lights.
 - Select TV mode and tune to the applied test pattern via local test keyboard.
Chassis should start normally.
 - Adjust all analogue controls (volume, bass, treble, brightness, contrast, colour) to minimum settings.
 - Adjust VR127 according to the following different types of CRT's

SYSTEM VOLTAGE

135V±0.5V

135V±0.5V

135V±0.5V

135V±0.5V

TYPE OF CRT

PHILIPS A66EAK552X54

PHILIPS A66EAK071X54

VIDEOCOLOR A66ECY13X12

PHILIPS W66ESF002X44

C) AFC ADJUSTMENT

- Inputs*
- AC power.
 - 38.9 MHz test pattern for PAL B/G, PAL-SECAM B/G or 39.5 MHz test pattern for PAL I model
(90dBmV) to Z403 SAW filter input terminals 1 and 2.
- Outputs*
- Digital Voltmeter to AFC point (pin22 of IC401)
- Display*
- AFC Voltage.
- Action*
- Adjust VL401 for 2.5±0.1 Volts. TV should automatically tune to a station when search tuning is activated.

D) FOCUS ADJUSTMENT

- Inputs*
- AC power
 - PAL B/G test pattern via RF input.
- Outputs*
- Picture tube drive.
- Display*
- Picture
- Action*
- Select TV mode and tune to the signal.
 - Adjust focus potentiometer (the upper pot on the rear side of the FBT transformer) for optimum focusing drive.

E) SCREEN ADJUSTMENT

- Inputs*
- AC power
 - PAL B/G Colour Bar test pattern via RF
- Outputs*
- 1/100 Oscilloscope probe to RGB cathodes on CRT baseboard.
NOTE: Ground pin of probe will be connected to 1st pin (GND) of the CRT socket.
- Display*
- RGB ratio
- Action*
- Select PAL B/G Colour Bar pattern using the local test keyboard and the user remote control unit.
 - Adjust all control functions (brightness, colour and contrast) to minimum settings.
 - Measure the most sensitive cathode
 - Adjust the screen potentiometer (lower pot on the rear side of FBT transformer) until cathode voltage becomes 150V.

F) IF ADJUSTMENT FOR L' MODE

- Inputs*
- AC power.
 - 38.9 MHz test pattern for PAL B/G, PAL-SECAM B/G or 39.5 MHz test pattern for PAL I model.
(90dBmV) to Z403 SAW filter input terminals 1 and 2.
- Outputs*
- Digital Voltmeter to AFC point. (pin22 of IC401)
 - Digital Voltmeter to AFC_L point. (pin14 of IC401)
- Display*
- AFC Voltage.
- Action*
- Firstly adjust VL401 for 2.5 ± 0.1 Volts. TV should automatically tune to a station.
when search tuning is activated.
 - Adjust VR401 for 2.5±0.1 Volts at the AFC_L point.

AK41 CHASSIS PRODUCTION MODE ADJUSTMENTS PROCEDURE

A) PRELIMINARY

All system, geometry and white balance alignments are performed in production service mode. Before starting the production mode alignments, make sure that all manual alignments are done correctly. To start production mode alignments enter the MAIN MENU and enter the code **1675** by pressing digit keys. Production mode items will appear on the screen. Production mode groups will be displayed with different colours of headlines, so in order to access a production alignment group press the colour key of the related group on the remote control transmitter. After selecting one of the production service mode groups, you can access its items by pressing the cursor-up and/or cursor-down keys. You can change the value of an item by pressing cursor-left and/or cursor-right keys on the remote control transmitter.

In order to switch between other group of items press the colour key of this groups headline.

To store the settings press OK key. In order to leave this menu press MENU key.

B) HORIZONTAL AND VERTICAL GEOMETRY ALIGNMENTS

- Switch the program to crosshatch test pattern.
- Press RED key to access this group of item.
- Select the items by pressing cursor-up and/or cursor-down keys.
- Adjust the item by pressing cursor-left and/or cursor-right after selecting that item.
- Store the settings by pressing OK key.
- Switch to another item group by pressing the colour keys of the related coloured headline of that group.
- Exit production mode by pressing the MENU key on the remote transmitter..

1) V-SHIFT

- Press cursor-left and/or cursor-right buttons till the test pattern is vertically centred, i.e. horizontal line at the centre of the test pattern is in equal distance both to upper and lower side of the picture tube. Check and readjust V-SHIFT item if the adjustment becomes improper after some other geometric adjustments are done

2) V-SIZE

- Press cursor-left and/or cursor-right buttons till horizontal black lines on both the upper and lower part of the test pattern become very close to the upper and lower horizontal sides of picture tube and nearly about to disappear. Check and readjust V-SIZE item if the adjustment becomes improper after some other geometric adjustments are done.

3) H-SHIFT

- Adjust H-SHIFT item by pressing cursor-left and/or cursor-right buttons till test pattern is horizontally in equal distance both to right and left sides of the picture tube. Check and readjust H-SHIFT item if the adjustment becomes improper after some other geometric adjustments are done.

4) H-SIZE

- Adjust H-WIDTH item by pressing cursor-left and/or cursor-right buttons till no under-scan condition will happen, i.e. no white bars on the left and right side of the test pattern will be visible nor the picture will be so wide. Check and readjust H-WIDTH item if the adjustment becomes improper after some other geometric adjustments are done.

5) S-COR

- Press cursor-left and/or cursor-right buttons till the size of squares on both the upper and lower part of test pattern become equal to the squares laying on the vertical centre of the test pattern. Check and readjust S-COR item if the adjustment becomes improper after some other geometric adjustments are done.

6) LINRT

- Press cursor-left and/or cursor-right buttons till all the size of squares of the test pattern become in equal size from the top of the screen to its bottom of the whole screen. Check and readjust LINRT item if the adjustment becomes improper after some other geometric adjustments (especially after than S-COR adjustment are done).

7) ANGLE

- Press cursor-left and/or cursor-right buttons till the vertical lines of the crosshatch pattern become completely perpendicular to horizontal lines without any angle of vertical deviation. Check and readjust ANGLE item if the adjustment becomes improper after some other geometric adjustments are done.

8) BOW

- Press cursor-left and/or cursor-right buttons till the vertical lines especially ones close to the left and right sides will of equal and symmetrical bending, i.e. they together will neither be towards left side nor right side. Check and readjust BOW item if the adjustment becomes improper after some other geometric adjustments are done.

9) TRPEZ

- Press cursor-left and/or cursor-right buttons till vertical lines, especially lines at the sides of the picture frame became parallel to the both sides of picture tube as close as possible. Check and readjust TRPEZ item if the adjustment becomes improper after some other geometric adjustments are done.

10) PARAB

- Press cursor-left and/or cursor-right buttons till vertical lines close to the both sides of the picture frame become parallel to vertical sides of picture tube without any bending to left or to right side of the screen.. Check and readjust PARAB item if the adjustment becomes improper after some other geometric adjustments are done.

11) U. COR

- Press cursor-left and/or cursor-right buttons till vertical lines at the upper corners of the picture frame become vertical and parallel to vertical corner sides of picture tube. Check and readjust U. COR item if the adjustment becomes improper after some other geometric adjustments are done.

12) L. COR

- Press cursor-left and/or cursor-right buttons till vertical lines at the lower corners of the picture frame become vertical and parallel to vertical corner sides of picture tube. Check and readjust L. COR item if the adjustment becomes improper after some other geometric adjustments are done.

C) VIDEO ALIGNMENTS

- Switch the program to crosshatch test pattern for geometric adjustments.
- Switch the program to colour bar test pattern for video adjustments.
- Press GREEN key to access this group of item.
- Select the items by pressing cursor-up and/or cursor-down keys.
- Adjust the item by pressing cursor-left and/or cursor-right after selecting that item.
- Store the settings by pressing OK key.
- Switch to another item group by pressing the colour keys of the related coloured headline of that group.
- Exit production mode by pressing the MENU key on the remote transmitter..

1) RGn, GGn, BGn: WHITE BALANCE ADJUSTMENT

-Apply WHITE test pattern via RF.

Adjust all analogue functions to medium level and set GGn, RGn, BGn at value 80, if needed.

Use Colour analyser and monitor the colour temperature (X, Y) on colour analyser.

Select RGn and BGn by cursor-up and/or cursor-down buttons and change the values by cursor-left and/or cursor-right buttons till the following values are read:

X=285±10

Y=293±10 on the colour analyser.

2) RRf, GRf, BRf

Set the values of these items as 62 (constant).

3) YDF

Apply COLOUR BAR test pattern.

Select YDF item cursor-up and/or cursor-down buttons.

Adjust YDF by pressing cursor-left and/or cursor-right buttons till the colour transients on the colour bar pattern becomes as sharper and possible as colours between transients do not mix with each other. Check and readjust YDF item if the adjustment becomes improper after YDV adjustment is done.

4) AGC

Apply PAL BG signal, VHF-3 Channel-12 and 60dBmV RF signal level.

Adjust AGC item till voltage at the AGC point (pin1 of the tuner) becomes 3.0 volts.

5) TLAN

This item and its settings will be defined later.

6) APS

This value of this item toggles between ON and OFF while pressing the cursor-left and cursor-right after this item is selected by cursor-up and/or cursor-down buttons.

In order to activate APS installation procedure whenever TV is turned select ON for the very first time.

In order to start TV without APS installation procedure select OFF.

7) T_T

This item is used for the Tuner Selection.

SAM, THO, SIE, ALP, MK2 and MK3 are for Samsung, Thomson, Siemens, Alps and Philips MP2/MP3, respectively.

8) T_P

This item is used for the Tuner Selection.

SAM, THO, TEM, and MK2 are for Samsung, Thomson, Temic, and Philips, respectively.

9) EXT3

This item is toggles between ON and OFF and is used to enable and disable EXT3, respectively.

10) CLT

This item is used to set the Menu colors. 5 choices are possible.

D) SERVICE ALIGNMENTS

IMPORTANT: There will no adjustments in this service mode during production mode alignments.

- Press BLUE key on the remote transmitter when Production mode is active.
- Press the colour key of the related item group's headline colour
- Press cursor-up and/or cursor-down to select the item of the group
- Press cursor-left and/or cursor-right to alter the value of the item.
- Press OK to store the values of items and MENU to exit the service alignments mode.

1) ADJUSTMENTS GROUP

Press RED key on the remote transmitter in order to access this group of items.

- PIP CNTRST , level of the PIP picture
- PIP YDelay , luma delay of the PIP picture
- PIP Frame , color selection of the PIP frame. (edges of the PIP)
- EHTHP , EHT compensation coefficient for horizontal phase
- EHTH TC , EHT time constant for horizontal phase compensation
- EHTH , EHT compensation coefficient for horizontal amplitude
- EHTV , EHT compensation coefficient for vertical amplitude
- EHTV TC , time constant for control of vertical and horizontal amplitude EHT compensation. (0 means off.)
- OSD LEVEL , contrast level of the OSD
- INIT NVM , to initiate the NVM

2) OPTIONS GROUP

- Press BLUE key on the remote transmitter in order to access this group of items.

- 0. HPHONE , on / off
- 1. CRT , 4:3 / 16:9
- 2. S-VHS , on / off
- 3. f(IF) , always set to 38.9
- 4. Türk. , turkish menu on/off
- 5. VGA , on / off
- 6. FRONT , FrontAV on/off

3) SYSTEM GROUP

- Press YELLOW key on the remote transmitter in order to access this group of items.

- 0. PAL B/G , on / off
- 1. PAL D/K , on / off
- 2. PAL I , on / off
- 3. SECAM B/G , on / off
- 4. SECAM D/K , on / off
- 5. SECAM L/L' , on / off
- 6. AUST. , on / off

GENERAL BLOCK DIAGRAM OF CHASSIS AK41

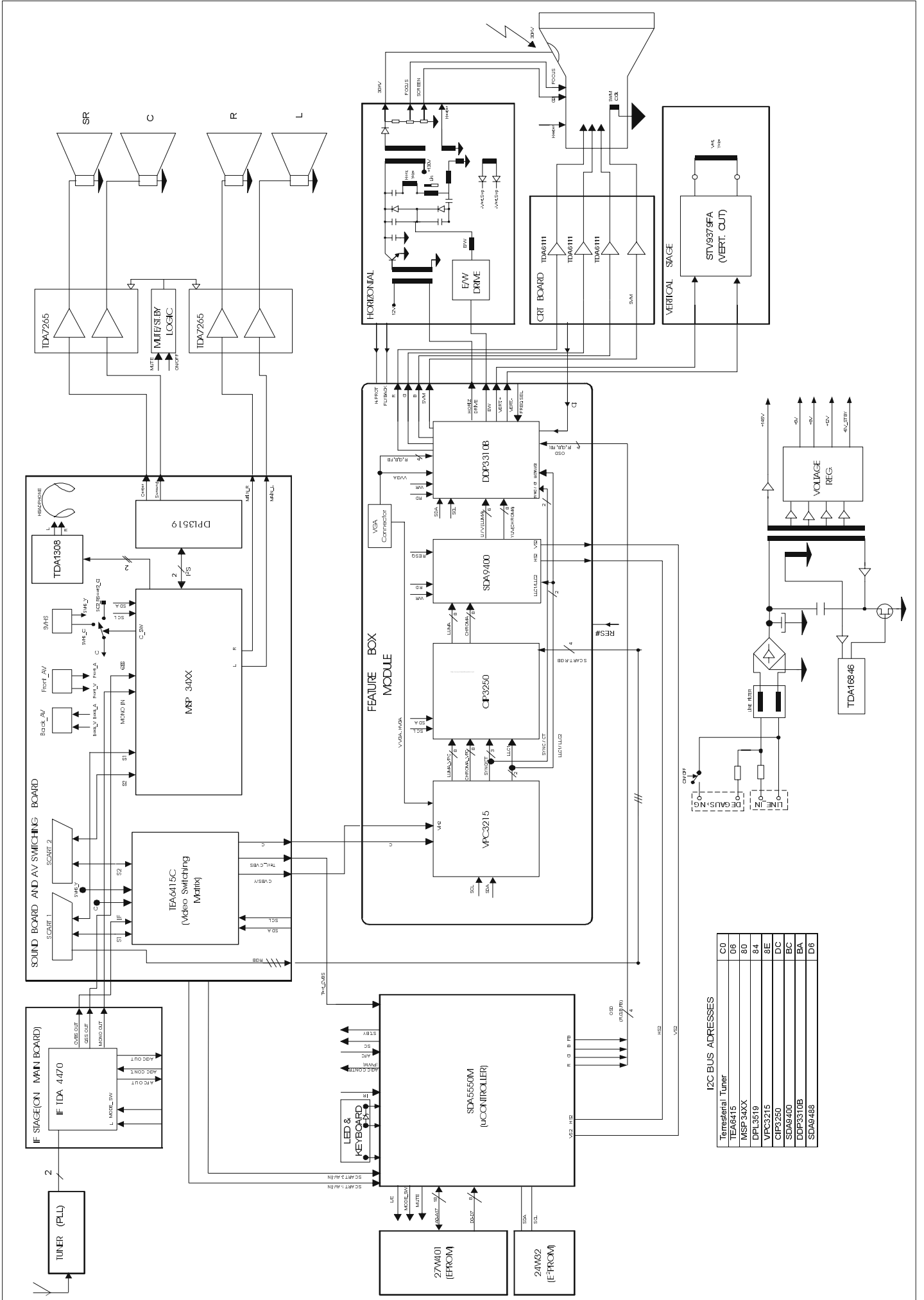

I2C BUS ADDRESSES

| Terrestrial Tuner | I2C Address |
|-------------------|-------------|
| TDA9415 | C0 |
| MSP 34XX | 06 |
| DP13519 | 80 |
| VPC3215 | 84 |
| CFP250 | 8E |
| SDA9400 | DC |
| DDP3310B | BA |
| SDA9488 | D6 |

Schematics

11AK41

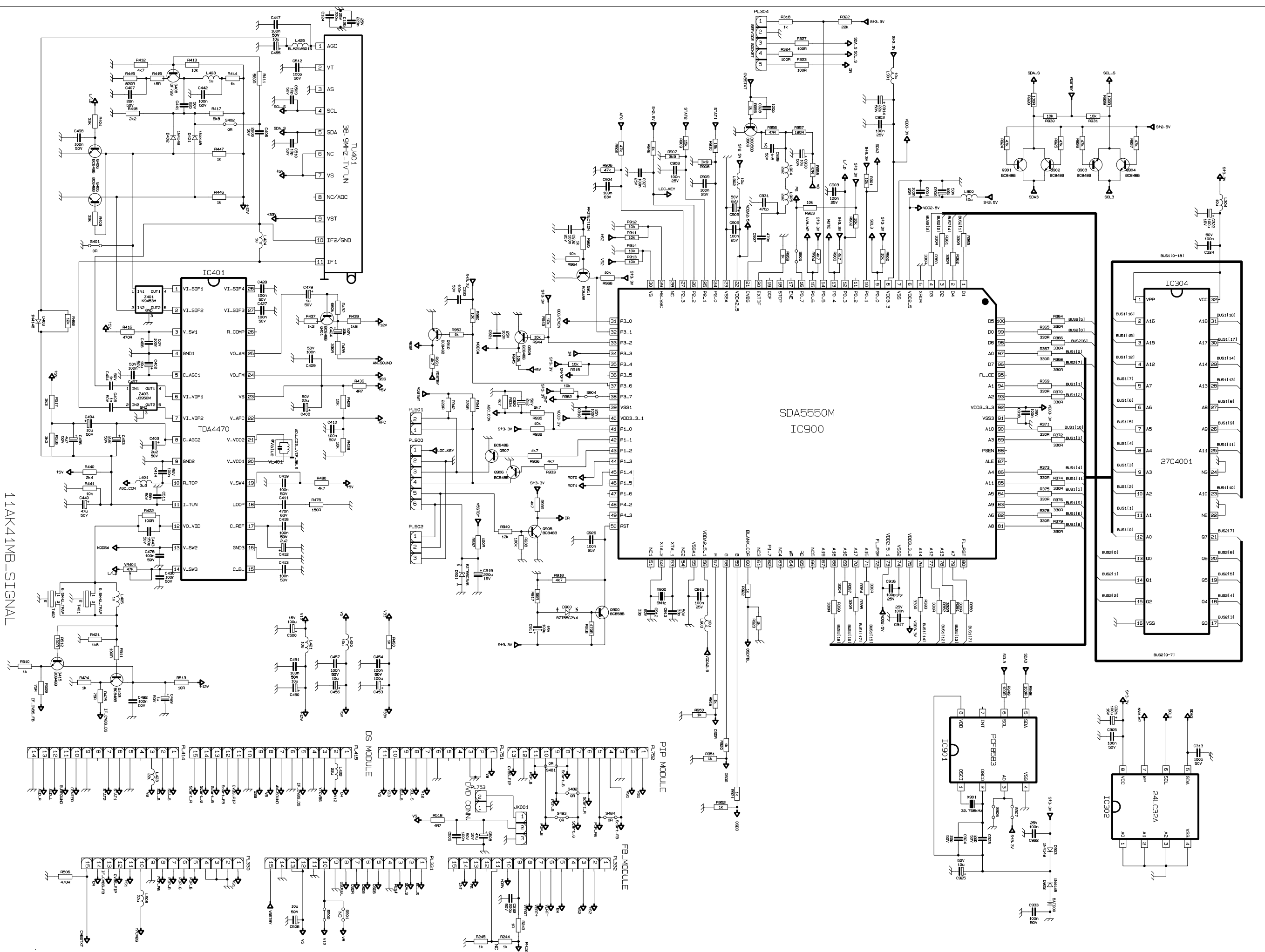

11AK4MB-SIGNAL

1
2
3
4
5
6
7
8
9
10
11
12
13
14
15
16
17
18
19
20
21
22
23
24
25
26
27
28
29
30
31
32
33
34
35
36
37
38
39
40
41
42
43
44
45
46
47
48
49
50
51
52
53
54
55
56
57
58
59
60
61
62
63
64
65
66
67
68
69
70
71
72
73
74
75
76
77
78
79
80
81
82
83
84
85
86
87
88
89
90
91
92
93
94
95
96
97
98
99
100

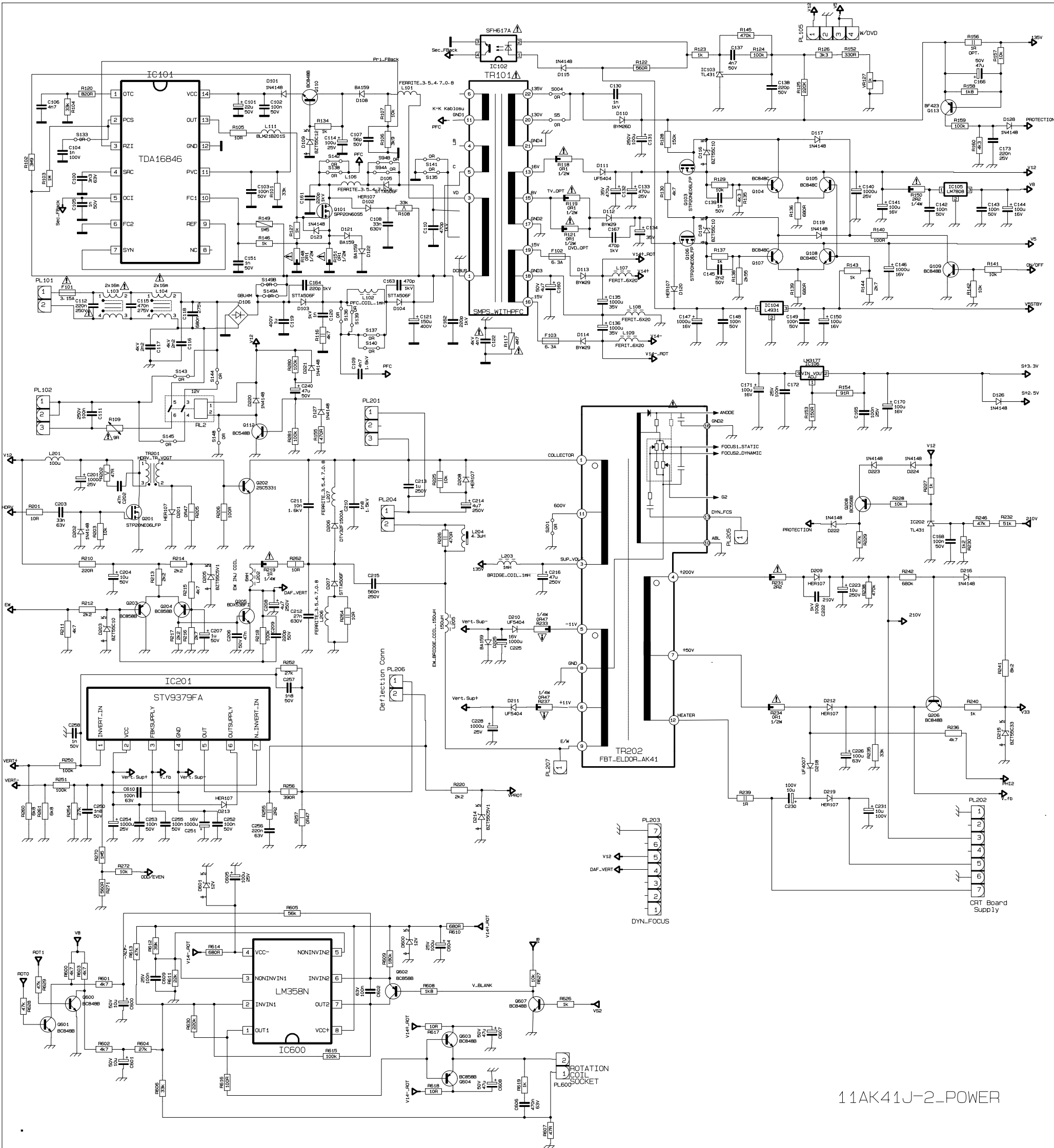

11AK41J-2-POWER

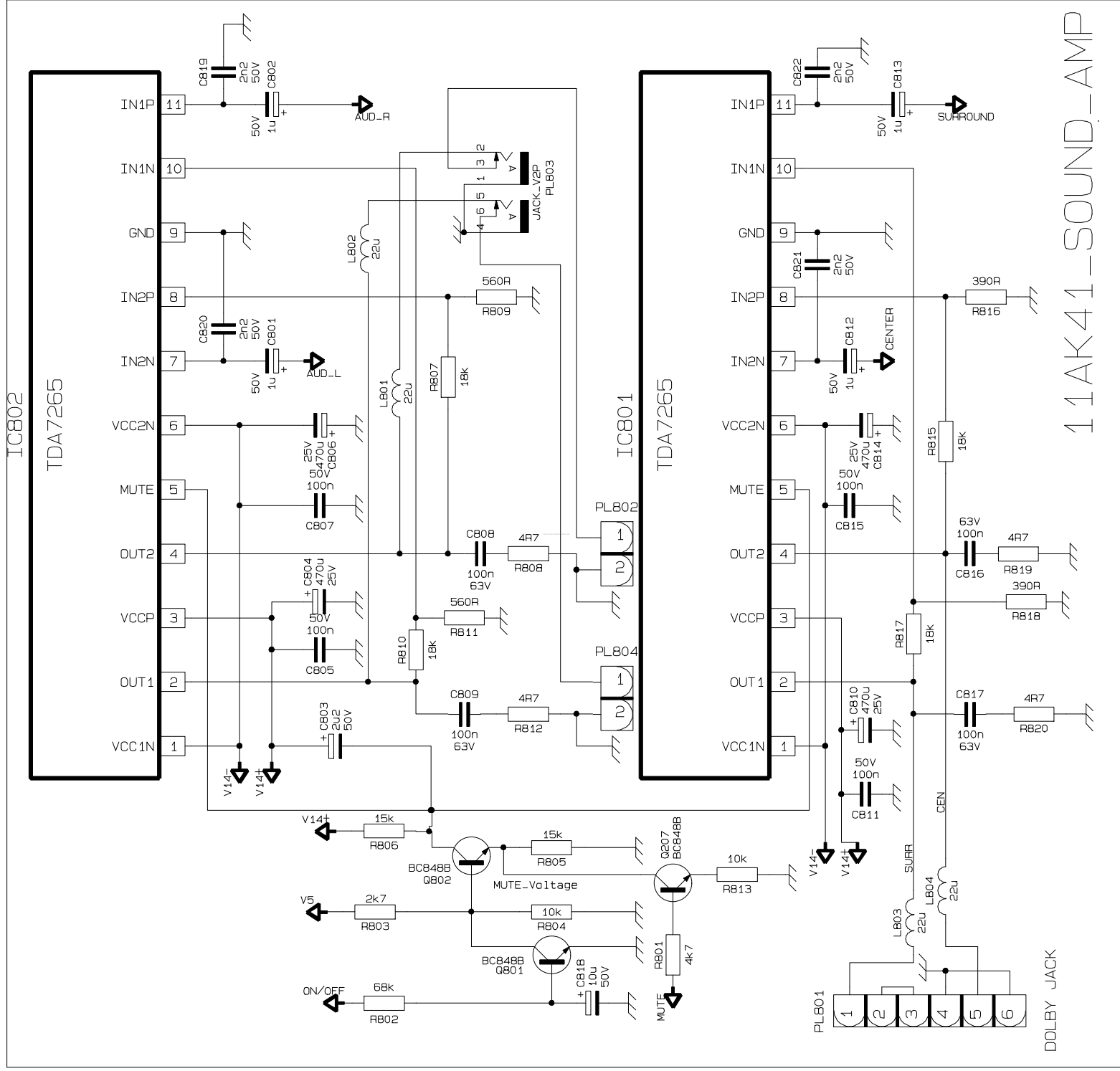

11AK41-2

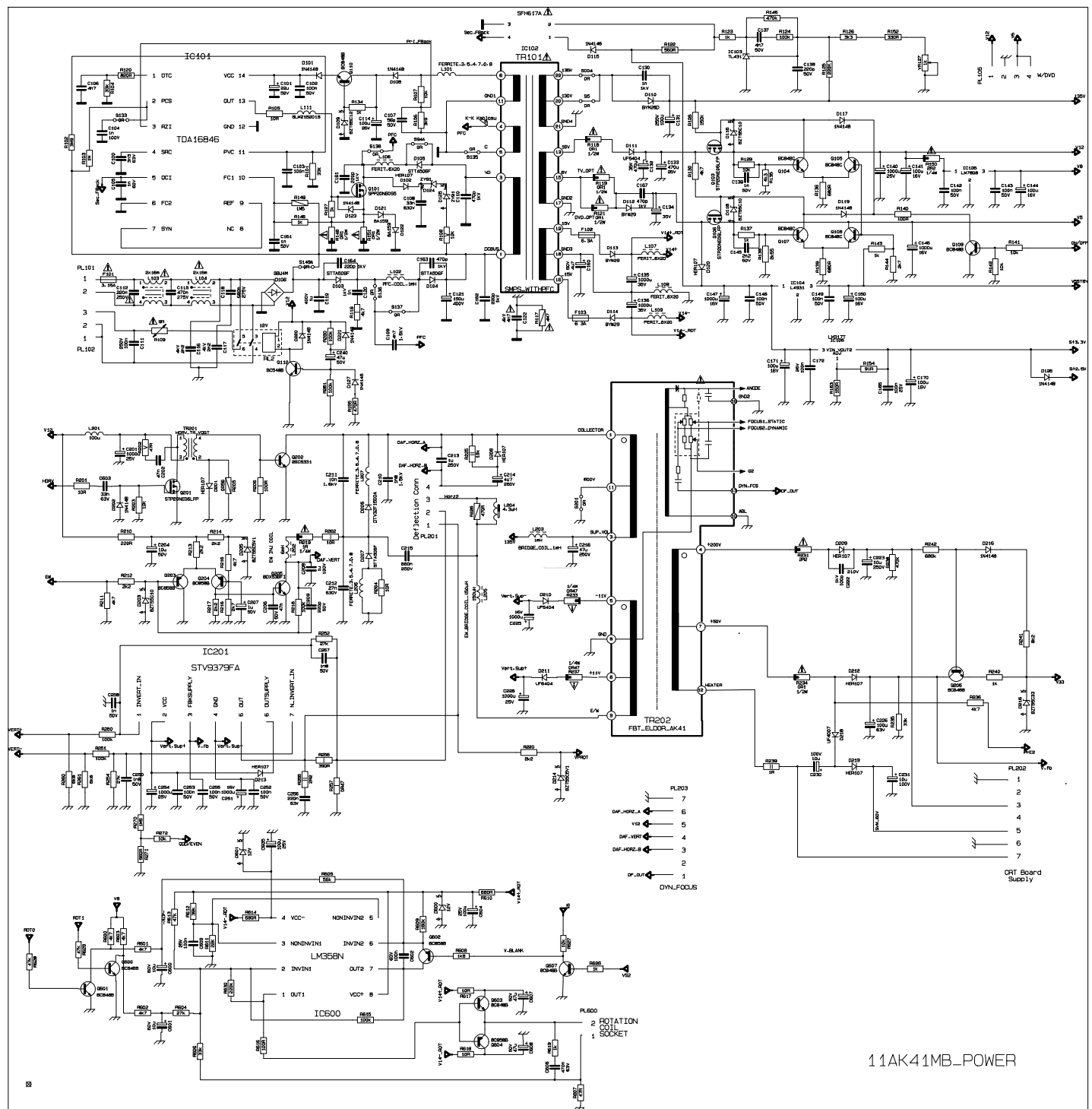

11AK41MB_POWER

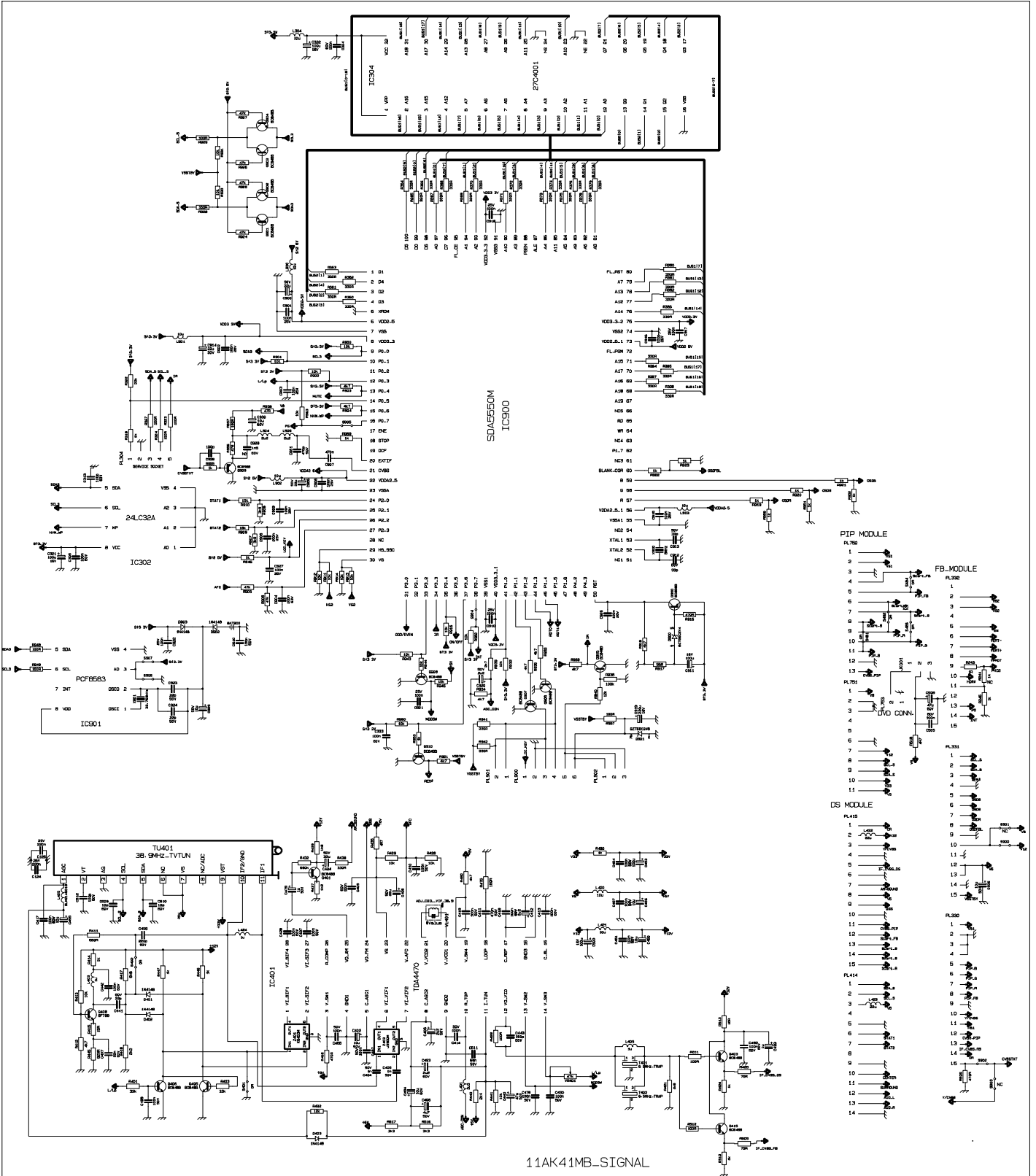

11AK41MB-SIGNAL

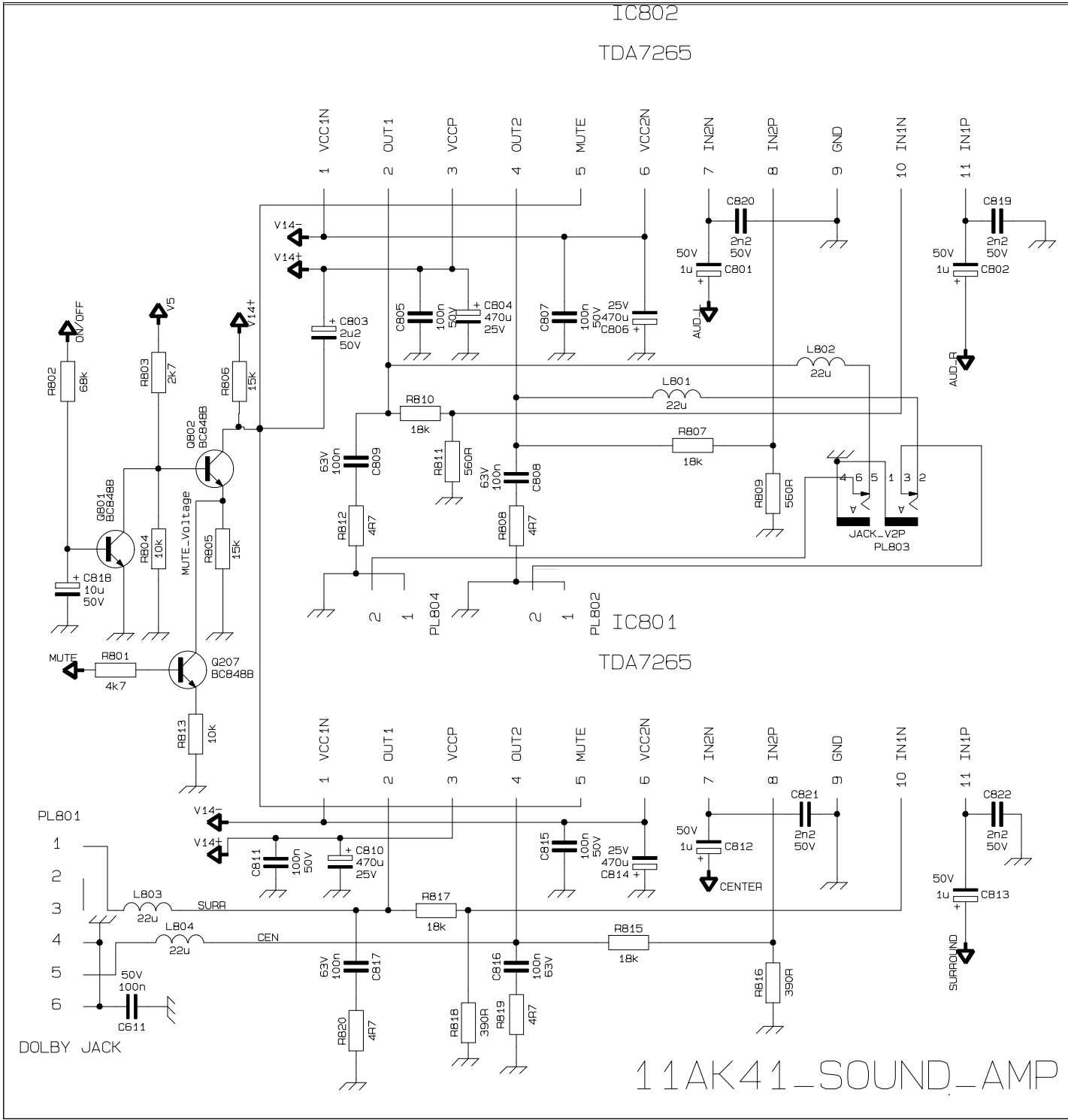

11AK41-3

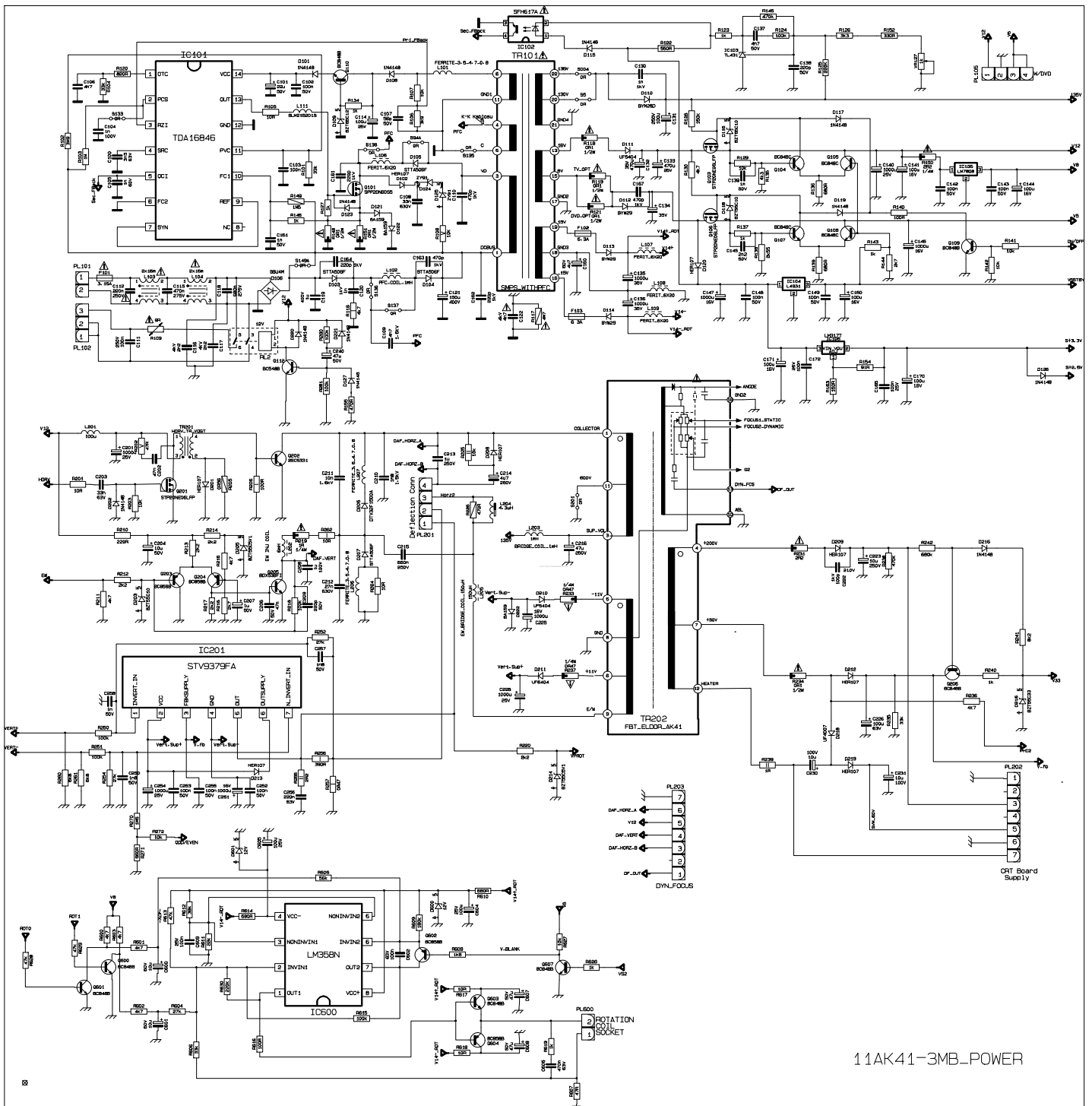

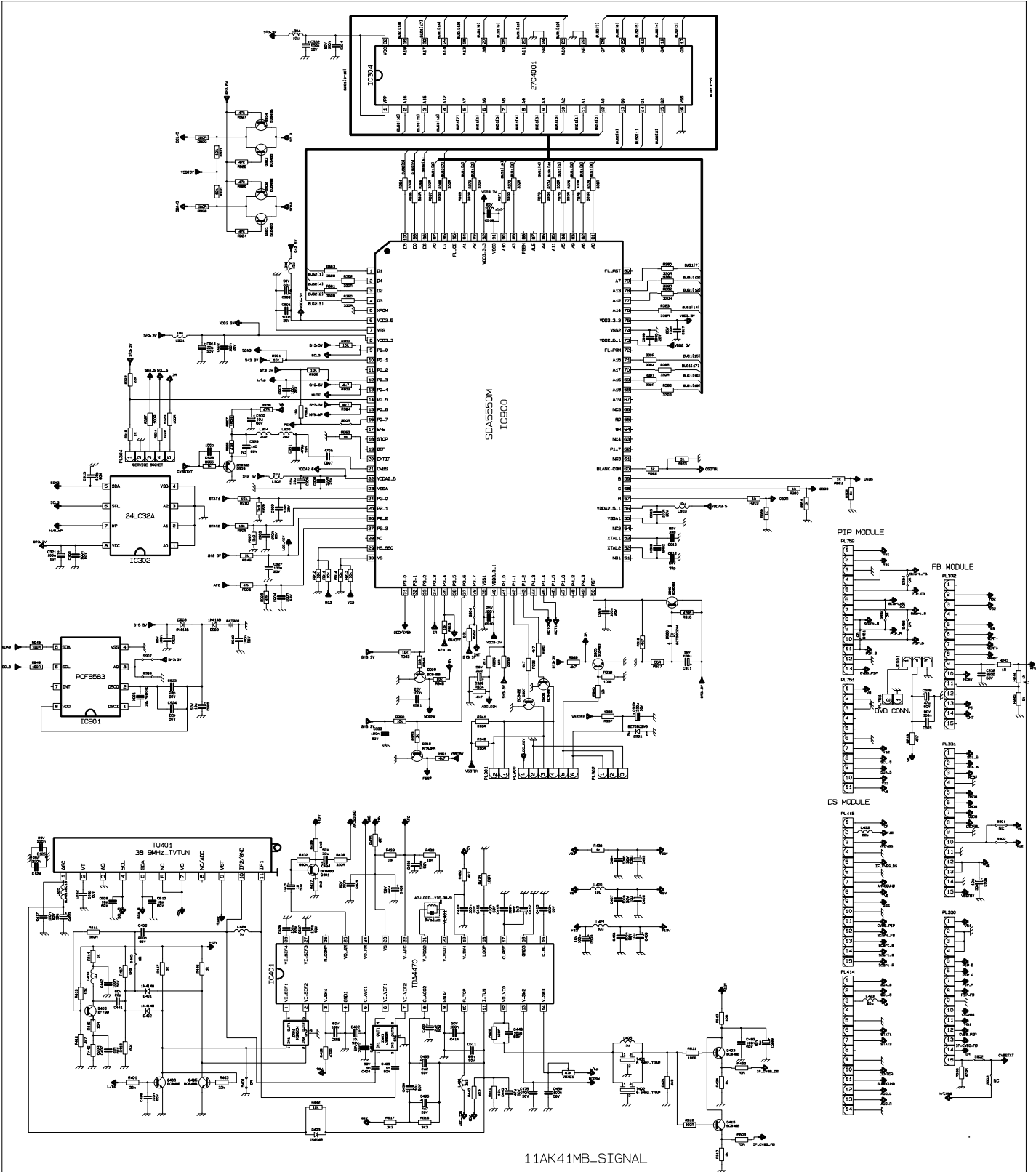

11AK41MB-SIGNAL

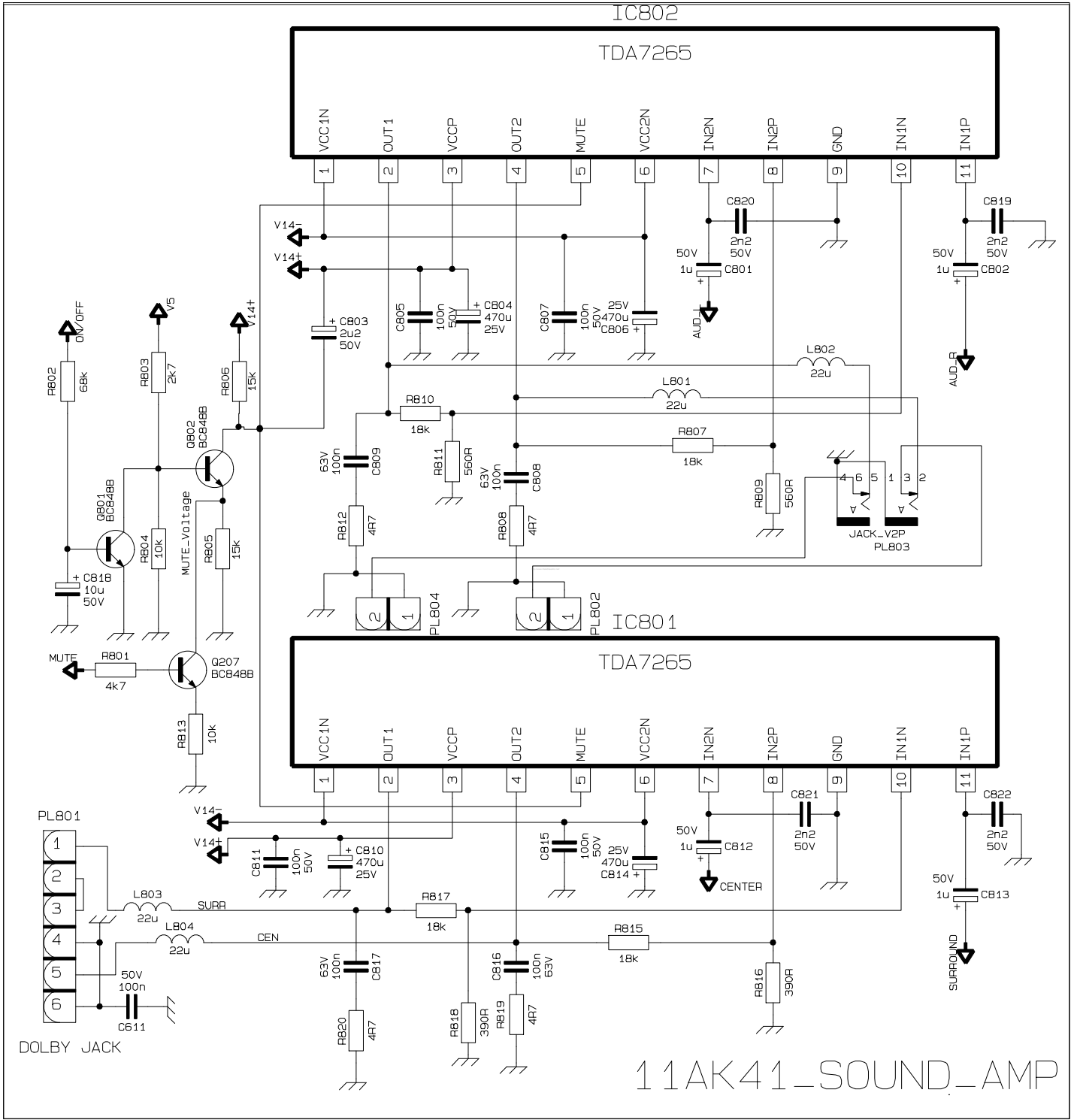

11AK41-J3

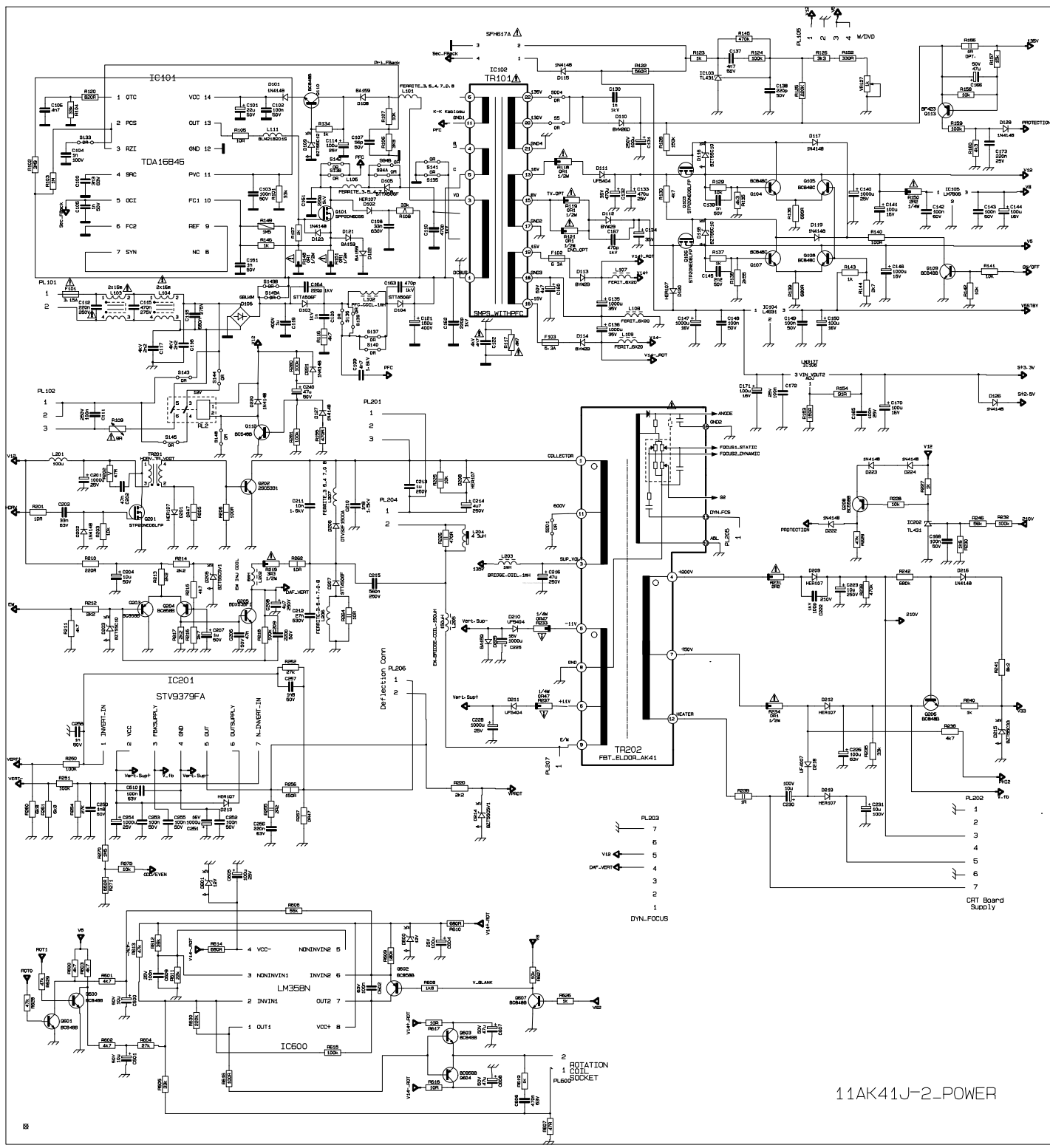

11AK41J-2_POWER

1

2

3

4

5

6

7

8

9

10

11

12

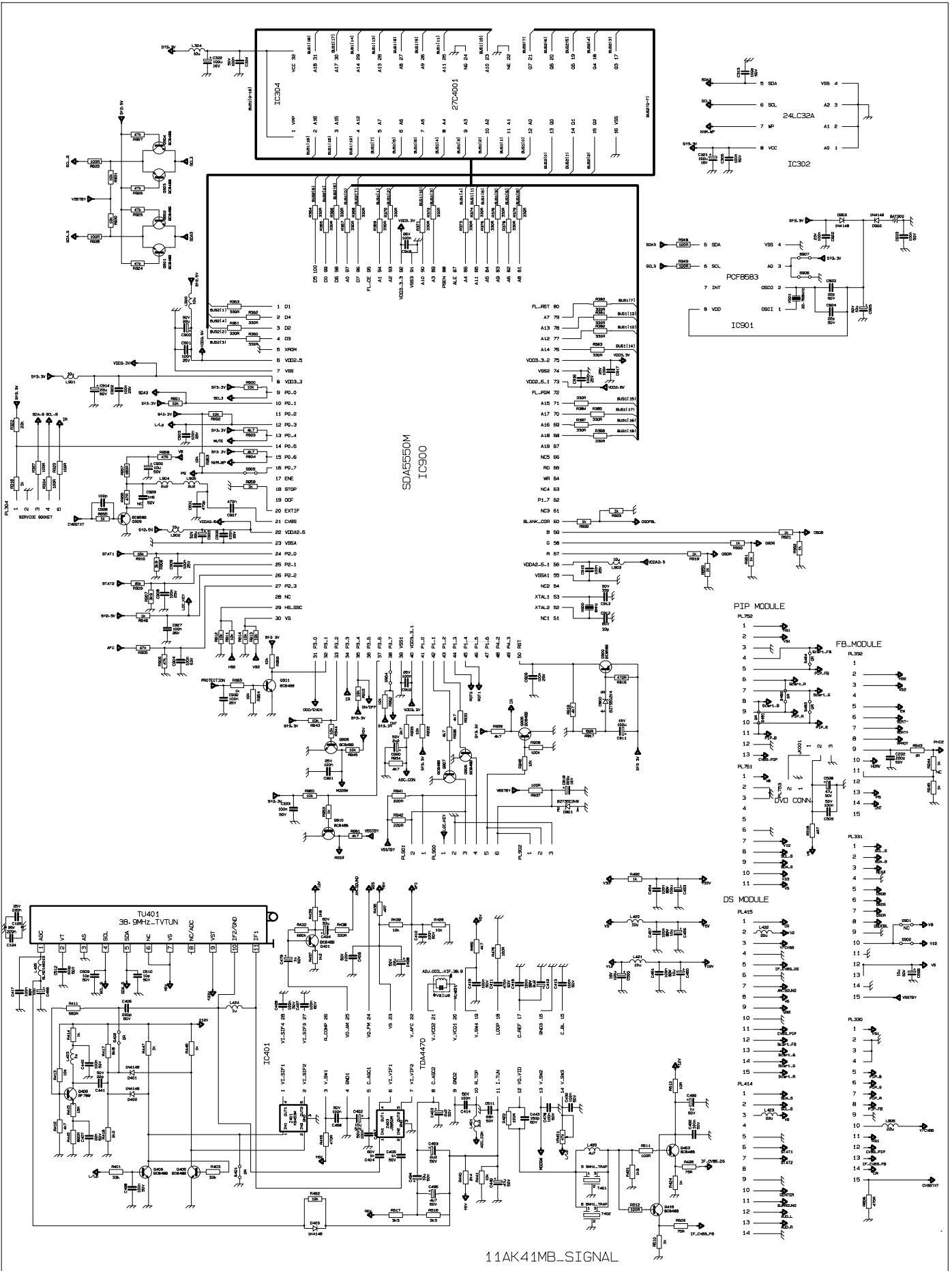

11AK41MB_SIGNAL

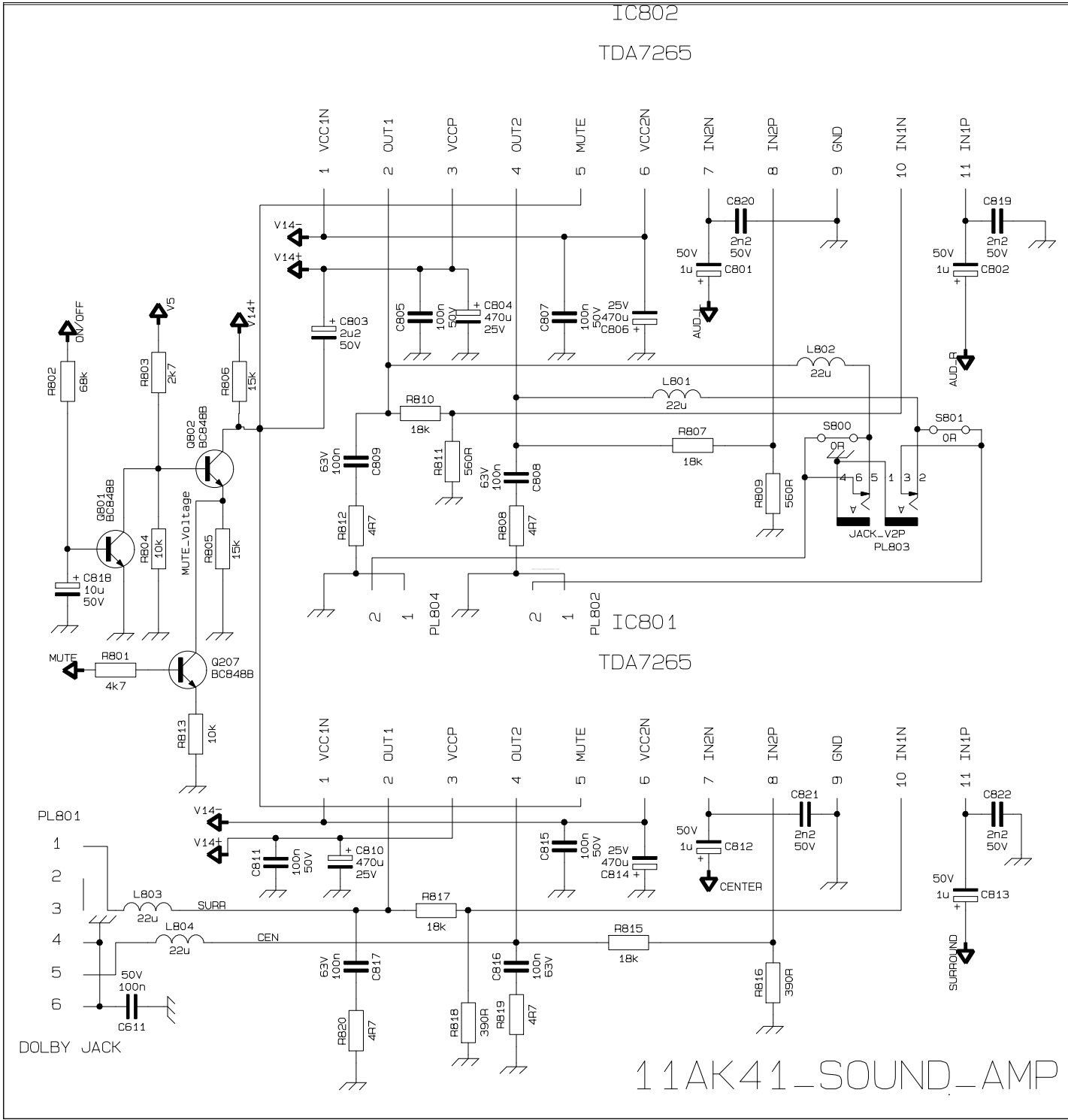

11AK41-J4

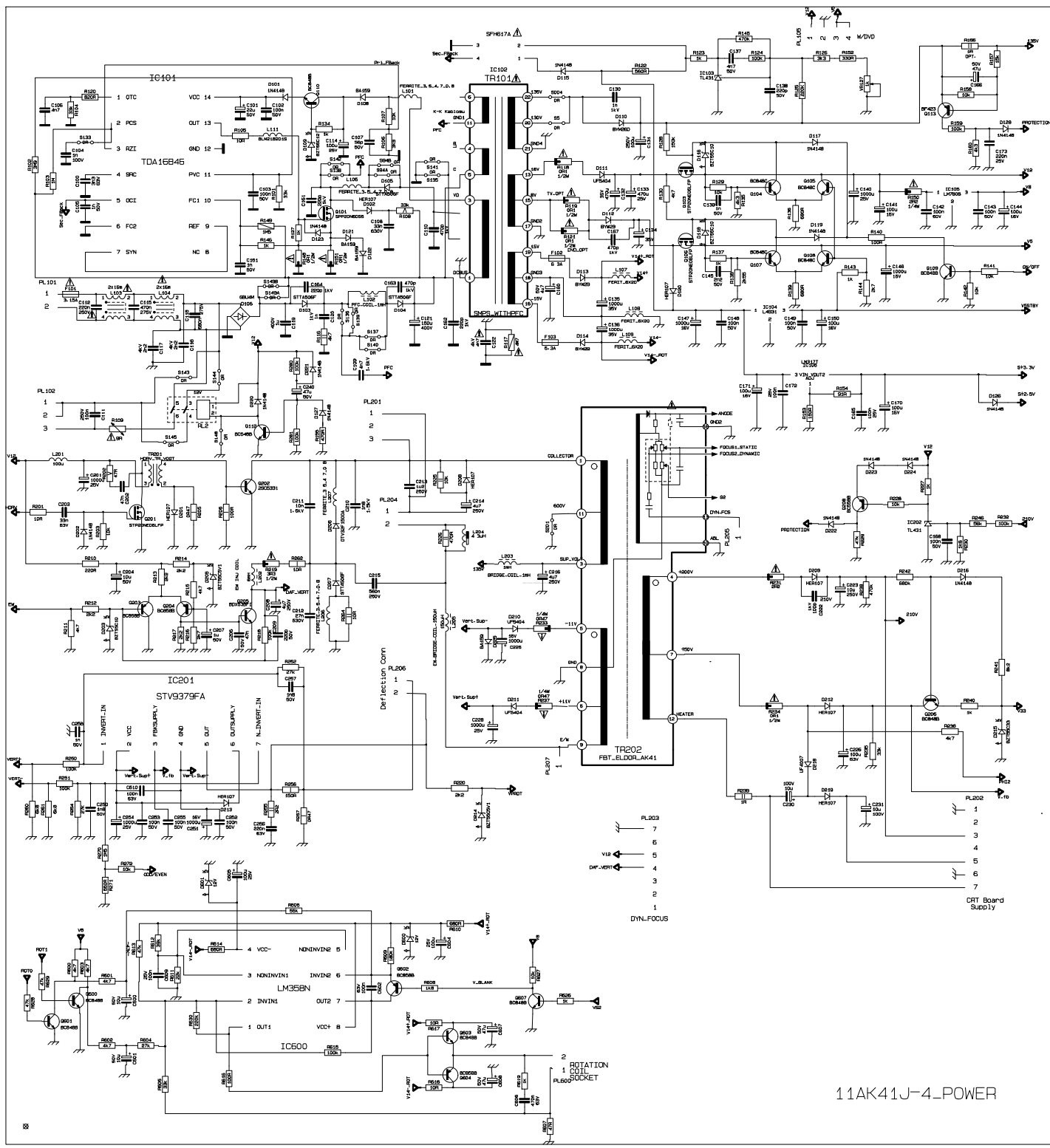

11AK41J-4-POWER

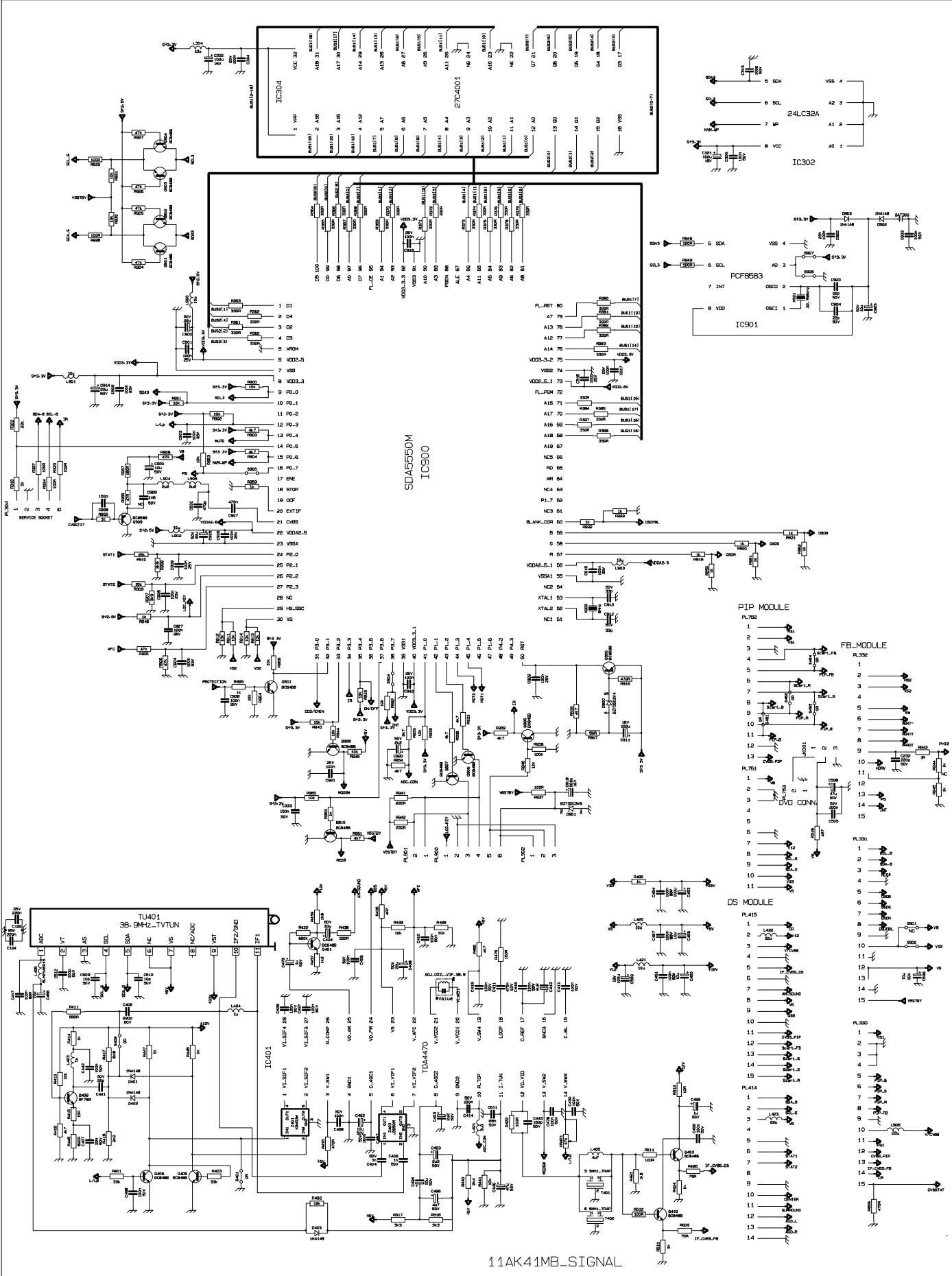

11AK41MB_SIGNAL

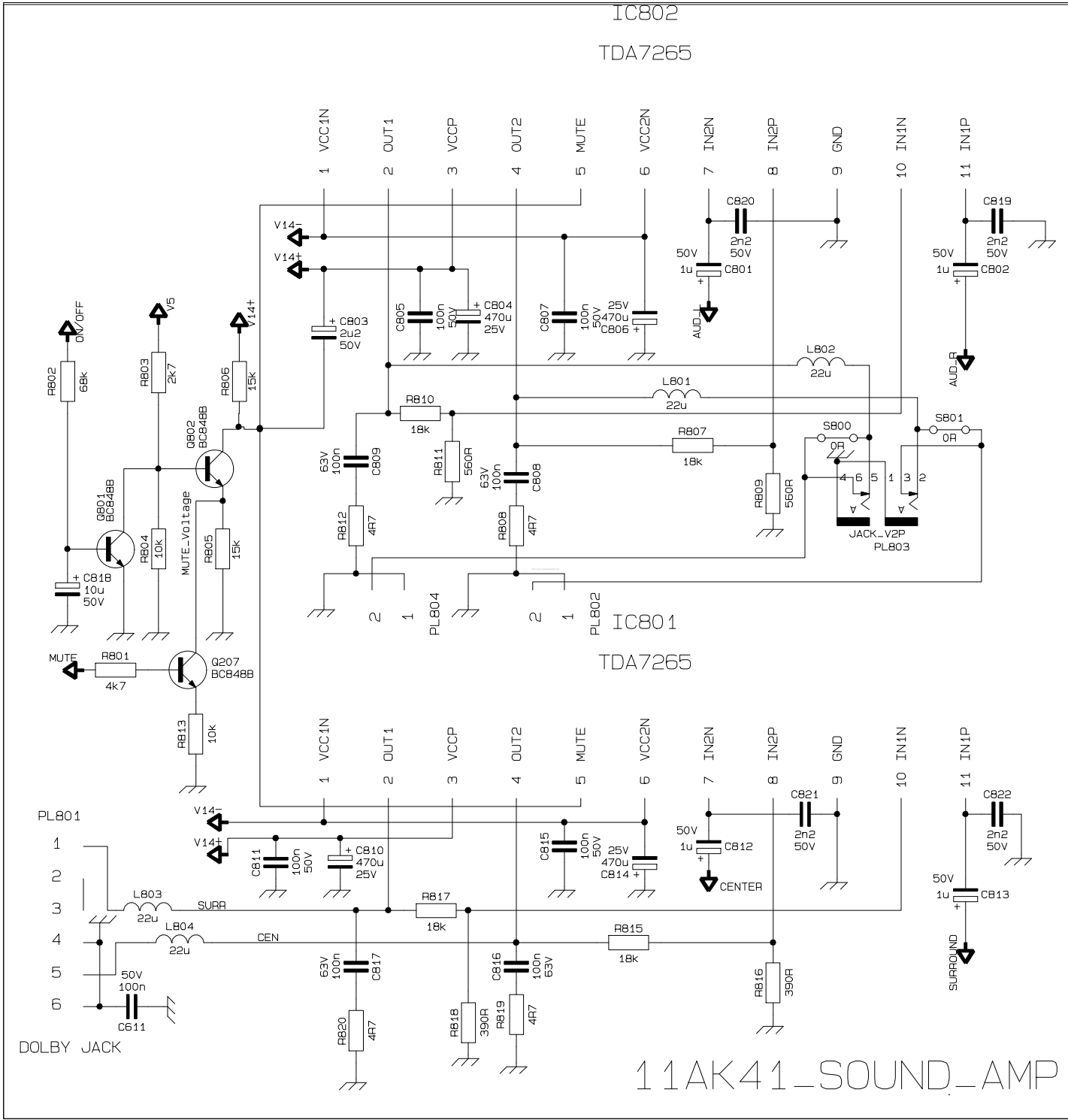

1 1AK41-SOUND-AMP

11AK41-J5

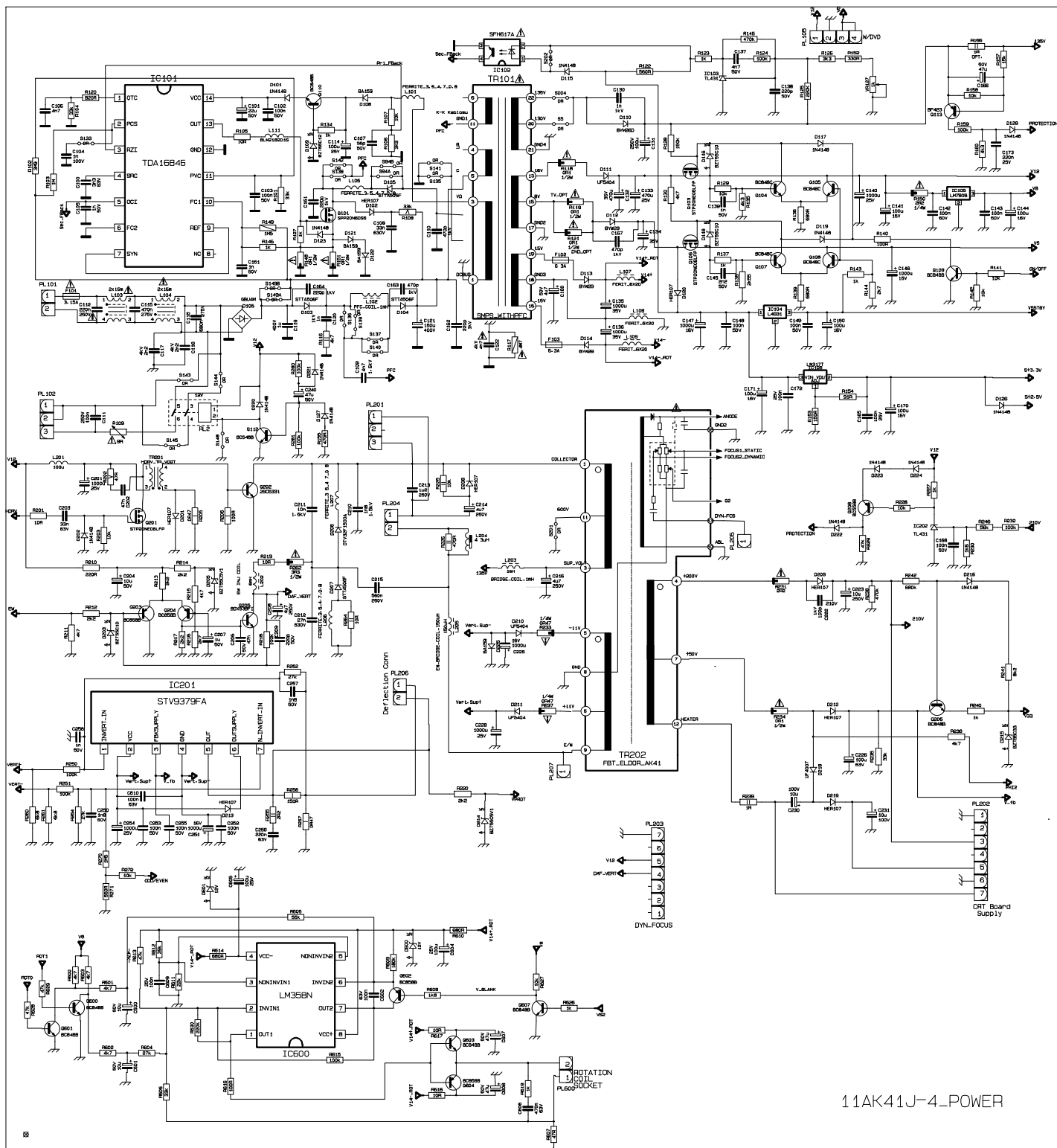

11AK41J-4 POWER

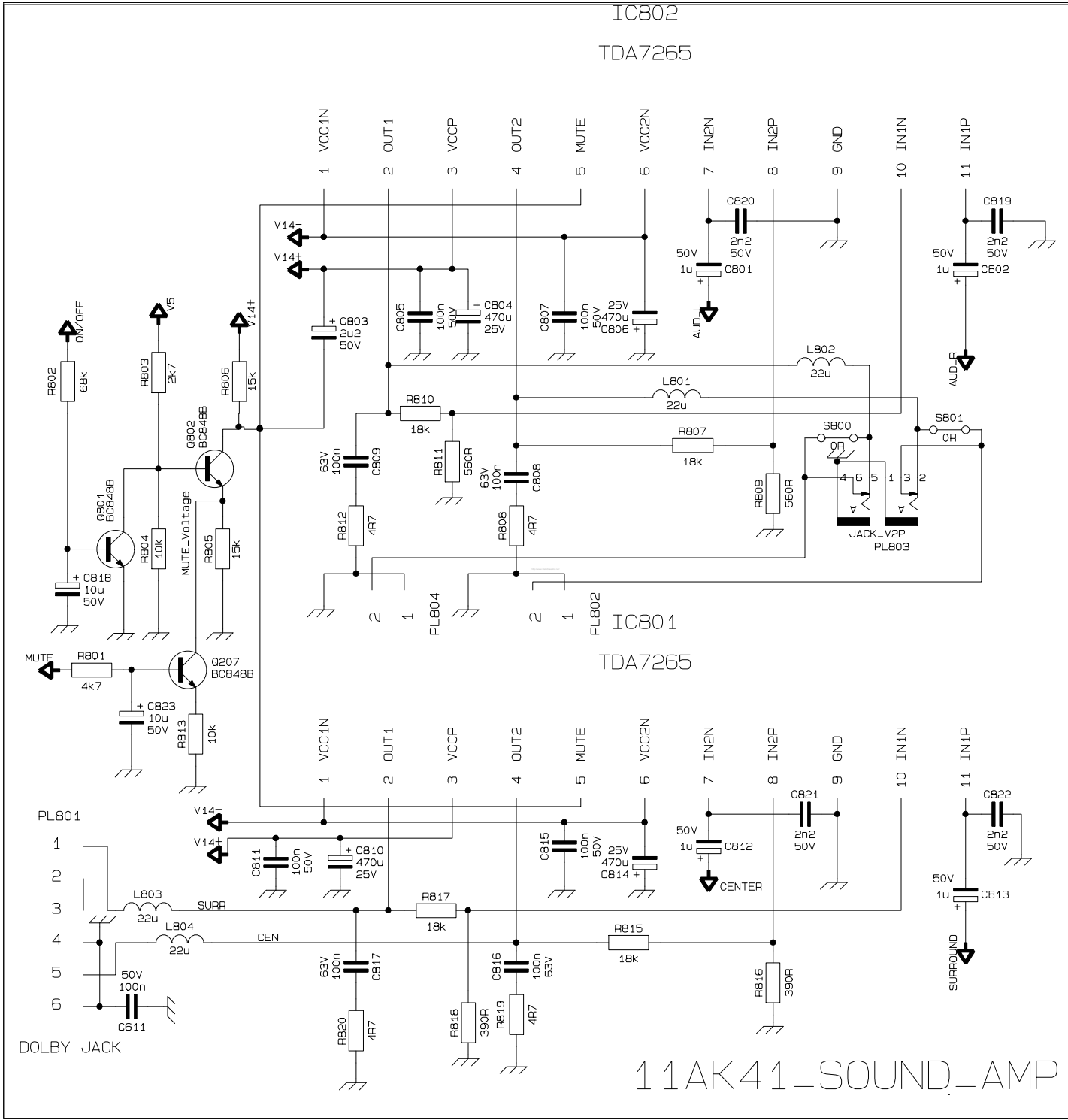

11AK41-SOUND-AMP

11AK41-J7

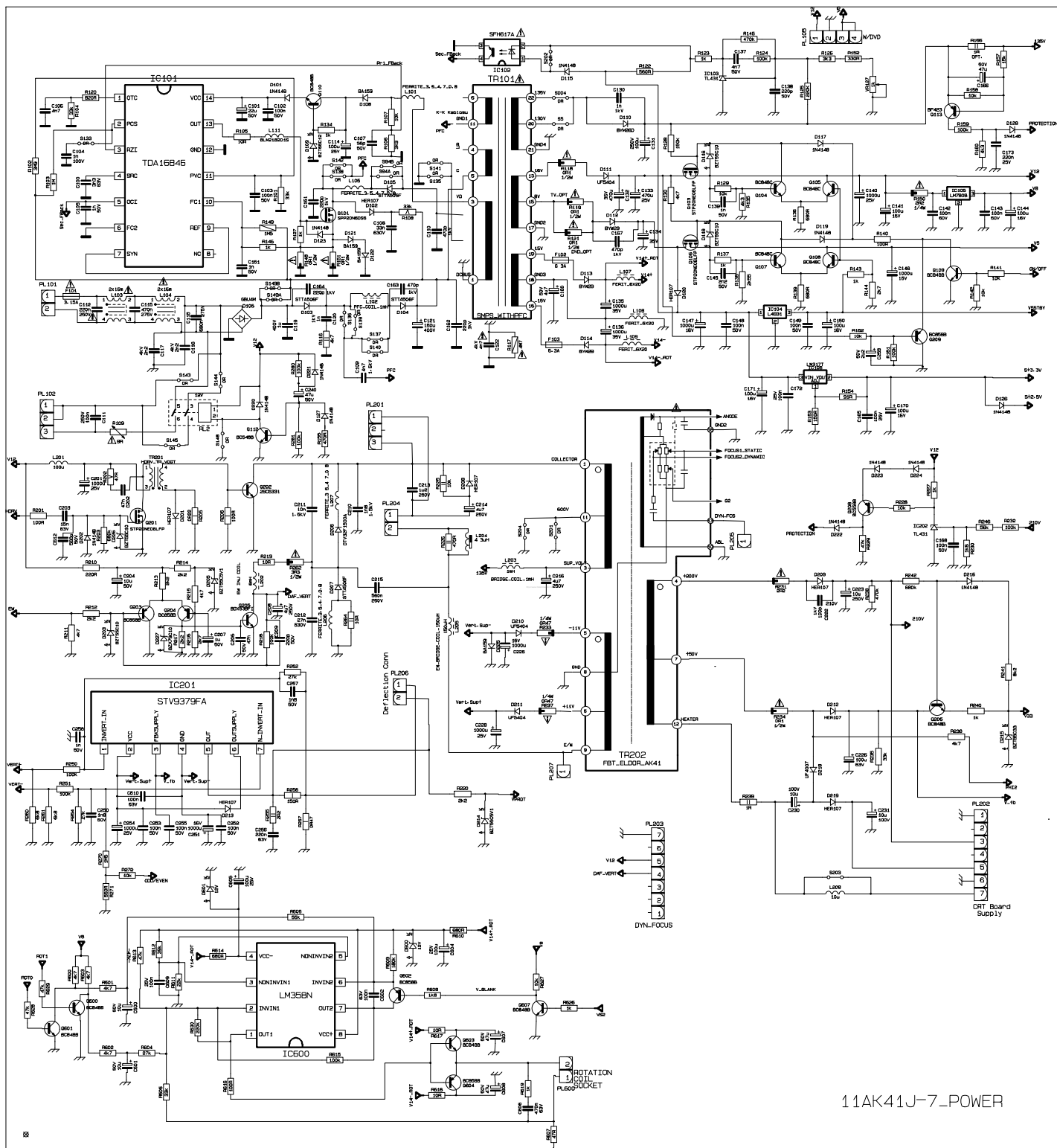

11AK41J-7_POWER

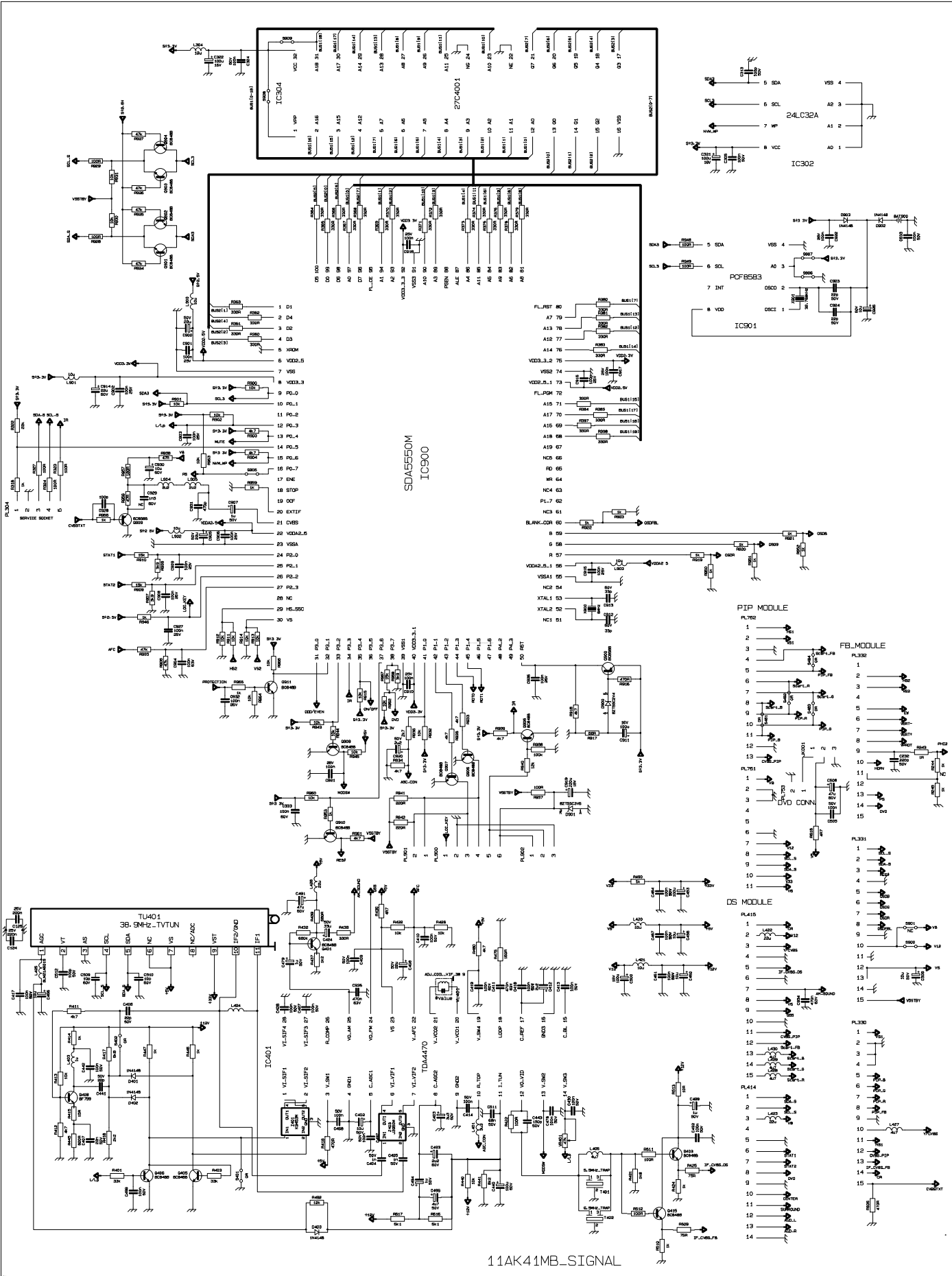

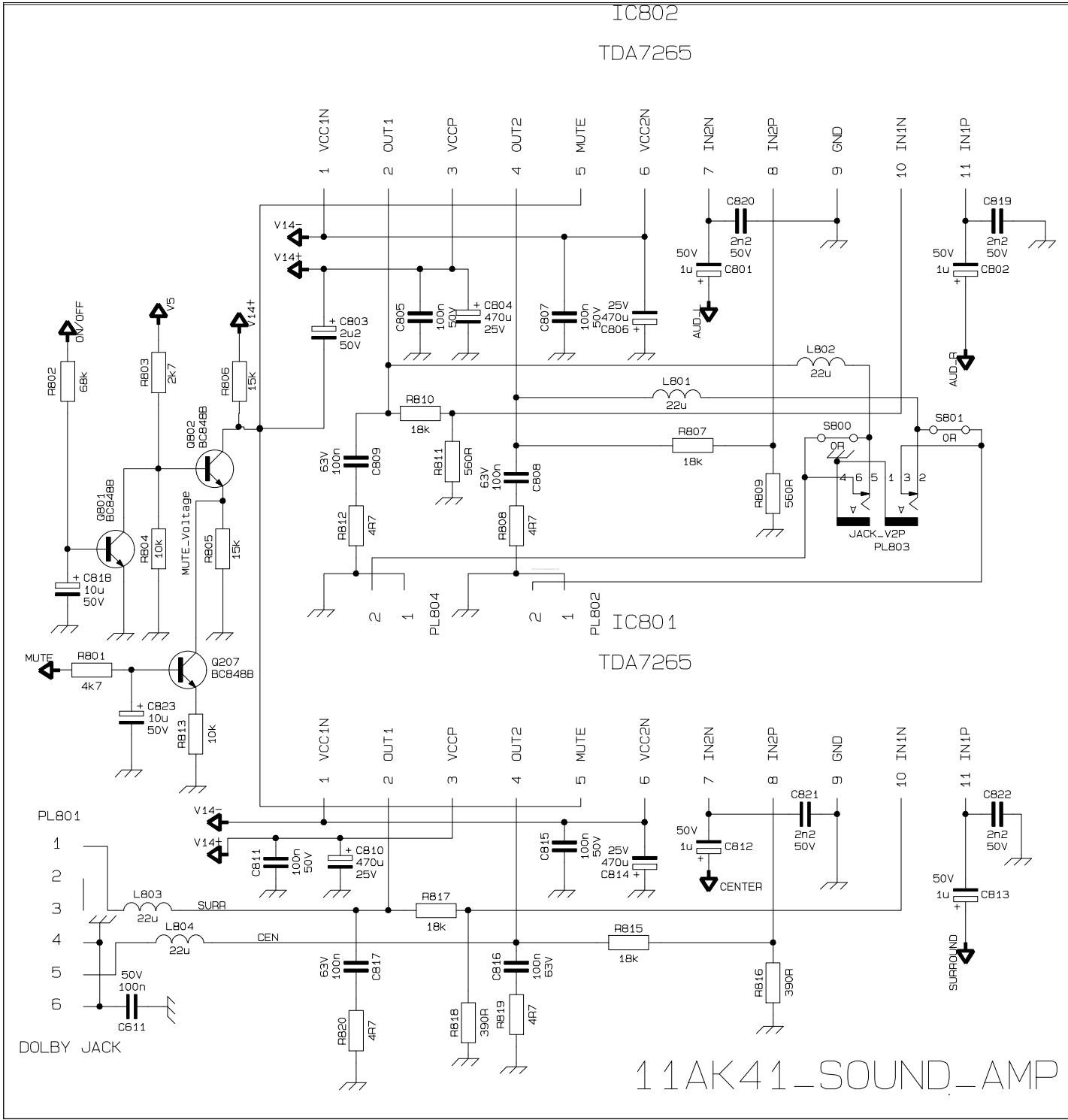

11AK41-SOUND-AMP

Parts List

BILL OF MATERIAL LIST

10016277

3241 TOSHIBA TOSHIBA 32WH37G(AK41)SILVER

| NO | PART NUMBER | DESCRIPTION | UNIT | QTY | POSITION NUMBER | | | | | |
|-----|-------------|--|------|--------|-----------------|------|------|------|------|---|
| 1 | V20062642 | SPK.AS.8270/71-3250/51 (AK28)WO/WYCOM | PC | 1,000 | . | . | . | . | . | . |
| 2 | V20062640 | SPK.AS.8270/71-3250/51 (AK28) L | PC | 1,000 | . | . | . | . | . | . |
| 3 | V30000426 | CAP EL 6.8UF 50V M (BPL) | PC | 1,000 | . | . | . | . | . | . |
| 4 | V30001946 | SPEAKER 8R 15W 57*160 | PC | 1,000 | . | . | . | . | . | . |
| 5 | V30001947 | TWEETER 8R 15W CLOSED | PC | 1,000 | . | . | . | . | . | . |
| 6 | V30002238 | CABL 2P/200 SPK DIS UL1672AWG24 | PC | 1,000 | . | . | . | . | . | . |
| 7 | V30014528 | CNAS 2P/100 SIS W/BLC UL1007 AWG24 | PC | 1,000 | . | . | . | . | . | . |
| 8 | V50011720 | LABEL HIGH END | PC | 1,000 | . | . | . | . | . | . |
| 9 | V20062641 | SPK.AS.8270/71-3250/51 (AK28) R | PC | 1,000 | . | . | . | . | . | . |
| 10 | V30000426 | CAP EL 6.8UF 50V M (BPL) | PC | 1,000 | . | . | . | . | . | . |
| 11 | V30001946 | SPEAKER 8R 15W 57*160 | PC | 1,000 | . | . | . | . | . | . |
| 12 | V30001947 | TWEETER 8R 15W CLOSED | PC | 1,000 | . | . | . | . | . | . |
| 13 | V30002238 | CABL 2P/200 SPK DIS UL1672AWG24 | PC | 1,000 | . | . | . | . | . | . |
| 14 | V30002349 | CNAS 2P/900 SPK DIS W/C UL2547 AWG24 | PC | 1,000 | . | . | . | . | . | . |
| 15 | V50011720 | LABEL HIGH END | PC | 1,000 | . | . | . | . | . | . |
| 16 | V20093219 | CRT KIT (32*16:9 SFLAT) AK41J WO/UL | PC | 1,000 | . | . | . | . | . | . |
| 17 | V30014862 | 32* 16:9 DEG COIL&EARTH CB. WO/UL SLAT | PC | 1,000 | . | . | . | . | . | . |
| 18 | V30016421 | CNAS 2P/600 VRT SIS W/C UL1007AWG24 | PC | 1,000 | . | . | . | . | . | . |
| 19 | V30016483 | CNAS 2P/600 HRZ DIS W/C UL1672AWG24 | PC | 1,000 | . | . | . | . | . | . |
| 20 | V20097687 | ON/OFF SW ASSY.FTZ(TOSHIBA)28*16:9-32-33 | PC | 1,000 | . | . | . | . | . | . |
| 21 | V30002174 | SWITCH ON/OFF 4A/64A | PC | 1,000 | . | . | . | . | . | . |
| 22 | V30002368 | CNAS 2P/650 AC MAINS W/C | PC | 1,000 | . | . | . | . | . | . |
| 23 | V30016513 | POWER CORD 2.2MT JVC (W/FILTER) | PC | 1,000 | . | . | . | . | . | . |
| 24 | V40000127 | SWITCH INSULATION DOOR LK101 | PC | 1,000 | . | . | . | . | . | . |
| 25 | V40001898 | MACARON (12cm.Isy ile daralan) | PC | 1,000 | . | . | . | . | . | . |
| 26 | V20098659 | SNOW BOX ASSY 324XW | PC | 1,000 | . | . | . | . | . | . |
| 27 | V20093536 | SNOW BOX BOTTOM 324XW | PC | 1,000 | . | . | . | . | . | . |
| 28 | V60000011 | EPS | KG | 0,564 | . | . | . | . | . | . |
| 29 | V20093537 | SNOW BOX TOP 324XW | PC | 1,000 | . | . | . | . | . | . |
| 30 | V60000011 | EPS | KG | 0,564 | . | . | . | . | . | . |
| 31 | V20102528 | MD.ASY.TK127-XX41-41W 5SW WO/DVD AK37-41 | PC | 1,000 | . | . | . | . | . | . |
| 33 | V30002181 | SWITCH TACT | PC | 5,000 | SW1 | SW2 | SW3 | SW4 | SW5 | |
| 34 | V30002302 | CNAS 6P/450 TB FLT W/C UL2468AWG24 | PC | 1,000 | PL1 | | | | | |
| 35 | V30019674 | LED RED ORANGE 5MM ULTRA BRIGHT | PC | 2,000 | LD1 | LD2 | | | | |
| 36 | V40000084 | BRACKET & PREAMPLIFIER | PC | 1,000 | IC1 | | | | | |
| 41 | V30000526 | RES CF 1/4W 1.5K J | PC | 1,000 | R2 | | | | | |
| 42 | V30000622 | RES CF 1/4W 270R J | PC | 1,000 | R5 | | | | | |
| 43 | V30000689 | RES CF 1/4W 3.9K J | PC | 1,000 | R1 | | | | | |
| 44 | V30000712 | RES CF 1/4W 470R J | PC | 1,000 | R4 | | | | | |
| 45 | V30000718 | RES CF 1/4W 4.7K J | PC | 1,000 | R6 | | | | | |
| 46 | V30000770 | RES CF 1/4W 680R J | PC | 1,000 | R3 | | | | | |
| 48 | V30022893 | PCB 11TK127-6 | PC | 1,000 | | | | | | |
| 49 | V30000371 | CAP EL 22UF 50V M | PC | 1,000 | C1 | | | | | |
| 50 | V30001455 | TR BC558B | PC | 1,000 | Q1 | | | | | |
| 51 | V20106208 | BUTTON AS.2841-2841W-3241W-2441W(SILVER) | PC | 1,000 | | | | | | |
| 52 | V20094341 | LENS LED XX41 (I) MILKY | PC | 1,000 | | | | | | |
| 53 | V60000008 | HIPS (NATURAL) | G | 0,014 | | | | | | |
| 54 | V60000927 | CRYSTAL PS (NATURAL) | G | 7,000 | | | | | | |
| 55 | V20094352 | LENS PRE-AMP XX41 (I) | PC | 1,000 | | | | | | |
| 56 | V60000927 | CRYSTAL PS (NATURAL) | G | 0,002 | | | | | | |
| 57 | V20106209 | BUTTON ON/OFF XX41 SILVER(P) | PC | 1,000 | | | | | | |
| 58 | V20106210 | BUTTON ON/OFF XX41 EKO.GRAY(I) | PC | 1,000 | | | | | | |
| 59 | V60000001 | ABS (NATURAL) | KG | 0,005 | | | | | | |
| 60 | V60001195 | MASTERBATCH EKO.GRAY GR 3216 SE1 | G | 0,026 | | | | | | |
| 61 | V60000895 | PAINT SILVER 022-6485 (SU BAZLI)L8341413 | KG | 0,002 | | | | | | |
| 62 | V20106211 | BUTTON FUNCTION XX41 SILVER(P) | PC | 1,000 | | | | | | |
| 63 | V20106222 | BUTTON FUNCTION XX41 EKO.GRAY(I) | PC | 1,000 | | | | | | |
| 64 | V60000001 | ABS (NATURAL) | KG | 0,020 | | | | | | |
| 65 | V60001195 | MASTERBATCH EKO.GRAY GR 3216 SE1 | G | 0,101 | | | | | | |
| 66 | V60000895 | PAINT SILVER 022-6485 (SU BAZLI)L8341413 | KG | 0,001 | | | | | | |
| 67 | V20108360 | BUTTON FUNCT.XX42/42W/43W/44W EKO.GR(I)# | PC | 1,000 | | | | | | |
| 68 | V60000001 | ABS (NATURAL) | KG | 0,018 | | | | | | |
| 69 | V60001195 | MASTERBATCH EKO.GRAY GR 3216 SE1 | G | 0,090 | | | | | | |
| 70 | V35000013 | SPRING ON/OFF SWITCH | PC | 1,000 | | | | | | |
| 71 | V20106289 | BACK C.3241/42/43/44W W/SB (UL)SILVER(P) | PC | 1,000 | | | | | | |
| 72 | V20106288 | BACK C.3241/42/43/44W SB(UL)EKO.GRAY(I) | PC | 1,000 | | | | | | |
| 73 | V60000009 | FR-HIPS NATR.V-0 | KG | 4,786 | | | | | | |
| 74 | V60001195 | MASTERBATCH EKO.GRAY GR 3216 SE1 | G | 24,050 | | | | | | |
| 75 | V60000895 | PAINT SILVER 022-6485 (SU BAZLI)L8341413 | KG | 0,125 | | | | | | |
| 76 | V20106290 | SCR.A.3241W W/SB/BAV AK41(V0)(GRAY) | PC | 1,000 | | | | | | |
| 77 | V20098439 | BACK DOOR AK28 EKO.GRAY (I) V.0 | PC | 1,000 | | | | | | |
| 78 | V60000009 | FR-HIPS NATR.V-0 | KG | 0,058 | | | | | | |
| 79 | V60001195 | MASTERBATCH EKO.GRAY GR 3216 SE1 | G | 0,580 | | | | | | |
| 80 | V35000211 | SCREW S C ZNSY YSMB 2.9*9.5 | PC | 4,000 | | | | | | |
| 81 | V35000214 | SCREW S C ZNSY YSMB 3.5*19 | PC | 2,000 | | | | | | |
| 82 | V35000224 | SCREW C SK ZN YFMB 2.9*9.5 | PC | 17,000 | | | | | | |
| 83 | V35000235 | SCREW P C ZN AKBR 7*32 | PC | 4,000 | | | | | | |
| 84 | V35004572 | SCREW P C AgSYF YSB 4x20 | PC | 8,000 | | | | | | |
| 85 | V40000082 | FOOT RUBBER 8410/11 | PC | 4,000 | | | | | | |
| 86 | V20107903 | CHS.ASSY.41J-5351411182126N | PC | 1,000 | | | | | | |
| 88 | V20055386 | MD.ASY.FB28-FEATURE BOX 28 (FB28-1) | PC | 1,000 | | | | | | |
| 90 | V20055388 | MD.SMD.FB28-FEATURE BOX 28 (FB28-1) | PC | 1,000 | | | | | | |
| 94 | V30001986 | FIXED COIL 3.3UH Q65 K | PC | 3,000 | L004 | L005 | L007 | | | |
| 95 | V30001992 | FIXED COIL 10UH Q65 K-A | PC | 3,000 | L001 | L002 | L003 | | | |
| 96 | V30015627 | PCB 11FB28-3 | PC | 1,000 | | | | | | |
| 97 | V30000109 | CAP MKT 470NF 63V J | PC | 4,000 | C035 | C078 | C079 | C25 | | |
| 98 | V30000345 | CAP EL 10UF 50V M | PC | 19,000 | C102 | C021 | C022 | C024 | C026 | |
| . | . | . | . | . | C027 | C028 | C036 | C037 | C074 | |
| . | . | . | . | . | C075 | C076 | C077 | C080 | C081 | |
| . | . | . | . | . | C082 | C098 | C099 | C108 | | |
| 99 | V30000371 | CAP EL 22UF 50V M | PC | 2,000 | C039 | C041 | | | | |
| 100 | V30000392 | CAP EL 0.33UF 50V M | PC | 4,000 | C101 | C040 | C042 | C043 | | |
| 101 | V30000393 | CAP EL 3.3UF 50V M | PC | 1,000 | C100 | | | | | |
| 102 | V30001454 | TR BC548B | PC | 11,000 | Q001 | Q002 | Q004 | Q005 | Q007 | |
| . | . | . | . | . | Q008 | Q010 | Q011 | Q013 | Q014 | |

BILL OF MATERIAL LIST

10016277

3241 TOSHIBA TOSHIBA 32WH37G(AK41)SILVER

| NO | PART NUMBER | DESCRIPTION | UNIT | QTY | POSITION NUMBER | | | | |
|-----|-------------|---|------|--------|-----------------|-------|-------|------|------|
| | | | | | Q015 | | | | |
| 103 | V30001455 | TR BC558B | PC | 4,000 | Q003 | Q006 | Q009 | Q012 | |
| 104 | V30001986 | FIXED COIL 3.3UH Q65 K | PC | 3,000 | L008 | L009 | L010 | | |
| 105 | V30001996 | FIXED COIL 22UH Q40 K | PC | 1,000 | L006 | | | | |
| 106 | V30000186 | CAP SMD 10PF 50V D COG 0805 | PC | 6,000 | C084 | C110 | C111 | C107 | C005 |
| | | | | | C006 | | | | |
| 107 | V30000228 | CAP SMD 27PF 50V J CH (0805) | PC | 2,000 | C054 | C055 | | | |
| 108 | V30000232 | CAP SMD 270PF 50V J (0805) | PC | 12,000 | C007 | C010 | C013 | C016 | C048 |
| | | | | | C051 | C056 | C085 | C088 | C089 |
| | | | | | C094 | C095 | | | |
| 109 | V30000242 | CAP SMD 330PF 50V J 0805 | PC | 4,000 | C029 | C031 | C033 | C113 | |
| 110 | V30000265 | CAP SMD 560PF 50V J (0805) | PC | 12,000 | C008 | C011 | C014 | C017 | C049 |
| | | | | | C052 | C057 | C073 | C087 | C090 |
| | | | | | C093 | C096 | | | |
| 111 | V30000284 | CAP SMD 1NF 50V K R (0805) | PC | 3,000 | C059 | C104 | C112 | | |
| 112 | V30000289 | CAP SMD 10NF 50V K R (0805) | PC | 11,000 | C038 | C060 | C063 | C064 | C065 |
| | | | | | C066 | C067 | C069 | C070 | C071 |
| | | | | | C103 | | | | |
| 113 | V30000294 | CAP SMD 100NF 50V K (0805) | PC | 12,000 | C002 | C020 | C045 | C046 | C047 |
| | | | | | C061 | C062 | C068 | C083 | C105 |
| | | | | | C106 | C109 | | | |
| 114 | V30000309 | CAP SMD 2.2NF 50V K R 0805 | PC | 15,000 | C001 | C004 | C009 | C012 | C015 |
| | | | | | C018 | C019 | C050 | C053 | C058 |
| | | | | | C072 | C086 | C091 | C092 | C097 |
| 115 | V30000334 | CAP SMD 47NF 50V K (0805) | PC | 1,000 | C003 | | | | |
| 116 | V30000464 | RES SMD 1/10W 100R J | PC | 13,000 | R002 | R079 | R085 | R091 | R155 |
| | | | | | R156 | R157 | R158 | R159 | R161 |
| | | | | | R162 | R163 | R164 | | |
| 117 | V30000469 | RES SMD 1/10W 1K J 0805 | PC | 6,000 | R120 | R007 | R034 | R084 | R090 |
| | | | | | R096 | | | | |
| 118 | V30000475 | RES SMD 1/10W 10K J 0805 | PC | 7,000 | R100 | R105 | R107 | R108 | R117 |
| | | | | | R119 | R033 | | | |
| 119 | V30000524 | RES SMD 1/10W 150R J (0805) | PC | 1,000 | R032 | | | | |
| 120 | V30000534 | RES SMD 1/10W 15K J (0805) | PC | 3,000 | R110 | R111 | R149 | | |
| 121 | V30000588 | RES SMD 1/10W 220R J 0805 | PC | 5,000 | R006 | R083 | R089 | R095 | R122 |
| 122 | V30000593 | RES SMD 1/10W 2.2K J (0805) | PC | 2,000 | R101 | R112 | | | |
| 123 | V30000597 | RES SMD 1/10W 22K J | PC | 2,000 | R050 | R098 | | | |
| 124 | V30000626 | RES SMD 1/10W 270R J | PC | 1,000 | R099 | | | | |
| 125 | V30000653 | RES SMD 1/10W 33R J | PC | 1,000 | R005 | | | | |
| 126 | V30000659 | RES SMD 1/10W 330R J (0805) | PC | 32,000 | R125 | R126 | R127 | R128 | R129 |
| | | | | | R130 | R131 | R132 | R133 | R134 |
| | | | | | R135 | R136 | R137 | R138 | R141 |
| | | | | | R142 | R143 | R144 | R145 | R001 |
| | | | | | R008 | R009 | R010 | R011 | R012 |
| | | | | | R013 | R014 | R015 | R016 | R017 |
| | | | | | R018 | R021 | | | |
| 127 | V30000664 | RES SMD 1/10W 3.3K J (0805) | PC | 1,000 | R106 | | | | |
| 128 | V30000688 | RES SMD 1/10W 390R J (0805) | PC | 4,000 | R003 | R080 | R086 | R092 | |
| 129 | V30000721 | RES SMD 1/10W 4.7K J | PC | 4,000 | R074 | R075 | R076 | R165 | |
| 130 | V30000797 | RES SMD 1/10W 75R J (0805) | PC | 21,000 | R024 | R026 | R028 | R030 | R047 |
| | | | | | R053 | R054 | R055 | R056 | R057 |
| | | | | | R058 | R059 | R082 | R088 | R094 |
| | | | | | R150 | R151 | R152 | R153 | R154 |
| | | | | | R140 | | | | |
| 131 | V30000833 | RES SMD 1/10W 91R J | PC | 1,000 | R031 | | | | |
| 132 | V30001284 | DIODE 1N4148 0.15A/100V 0.5A | PC | 3,000 | D001 | D002 | D003 | | |
| 134 | V30006462 | RES SMD 1/10W 22R J 0805 | PC | 6,000 | R121 | R004 | R048 | R081 | R087 |
| | | | | | R093 | | | | |
| 135 | V30007668 | IC SDA9400 | PC | 1,000 | IC003 | | | | |
| 136 | V30007739 | IC LM317T D2PAK | PC | 1,000 | IC004 | | | | |
| 137 | V30010348 | IC CIP3250A | PC | 1,000 | IC002 | | | | |
| 138 | V30010349 | IC DDP3310 | PC | 1,000 | IC005 | | | | |
| 139 | V30010350 | IC VPC3211 | PC | 1,000 | IC001 | | | | |
| 140 | V30010560 | CAP SMD 220NF 25V K R (0805) | PC | 3,000 | C030 | C032 | C034 | | |
| 142 | V30001813 | CONN HOUSING 15P 2.5MM SIDE WHT | PC | 3,000 | PL001 | PL002 | PL003 | | |
| 143 | V30001962 | FERRITE AK18 VIDEO | PC | 9,000 | Z1 | Z10 | Z14 | Z18 | Z24 |
| | | | | | Z25 | Z26 | Z37 | Z38 | |
| 144 | V30007745 | CONN HEADER 10P 2.54MM SIDE WHT DR | PC | 1,000 | PL004 | | | | |
| 145 | V30008778 | XTAL 20.25MHZ | PC | 1,000 | X001 | | | | |
| 146 | V30008782 | XTAL 5MHZ | PC | 1,000 | X002 | | | | |
| 147 | V35001857 | SHIELD SOLDER SIDE (FEATURE BOX-11AK28) | PC | 1,000 | | | | | |
| 148 | V35003011 | SHIELD COVER (FEATURE BOX AK28) | PC | 1,000 | | | | | |
| 149 | V35003321 | SHIELD COMPONENT SIDE-1(F-BOX AK28) | PC | 1,000 | | | | | |
| 150 | V20082412 | MD.ASY.ST41J-FAV+HP+BAV+VD | PC | 1,000 | | | | | |
| 153 | V30001207 | RES FUSE 1/4W 10R J | PC | 1,000 | R535 | | | | |
| 154 | V30001619 | IC VIDEO SWITCH TEA6415C DIP20 | PC | 1,000 | IC502 | | | | |
| 155 | V30001756 | XTAL 18.432MHZ | PC | 1,000 | X501 | | | | |
| 156 | V30001811 | CONN HOUSING 14P 2.5MM SIDE WHT | PC | 1,000 | PL504 | | | | |
| 157 | V30001813 | CONN HOUSING 15P 2.5MM SIDE WHT | PC | 1,000 | PL503 | | | | |
| 158 | V30001866 | SOCKET SCART (R) VER BLACK | PC | 1,000 | PL501 | | | | |
| 159 | V30001867 | SOCKET SCART (R) VER BLUE | PC | 1,000 | PL506 | | | | |
| 161 | V30001518 | IC TDA1308 | PC | 1,000 | IC503 | | | | |
| 162 | V30001842 | CONN HEADER 3P 2.5MM SIDE BLUE SD | PC | 1,000 | PL508 | | | | |
| 164 | V30001833 | CONN HEADER 2P 2.5MM SIDE BLUE SD | PC | 1,000 | PL507 | | | | |
| 165 | V30001844 | CONN HEADER 3P 2.5MM SIDE GREEN SD | PC | 1,000 | PL502 | | | | |
| 167 | V30001880 | JACK RCA 3P (BACK AV) 180° | PC | 1,000 | JK501 | | | | |
| 169 | V30009354 | IC MSP3411 SDIP64 | PC | 1,000 | IC501 | | | | |
| 171 | V20077175 | MD.SMD.ST41-COMMON | PC | 1,000 | | | | | |
| 176 | V30000452 | RES CF 1/4W 10R J | PC | 2,000 | R539 | R552 | | | |
| 177 | V30000459 | RES CF 1/4W 100R J | PC | 4,000 | R503 | R504 | R532 | R533 | |
| 178 | V30000466 | RES CF 1/4W 1K J | PC | 1,000 | R513 | | | | |
| 179 | V30000583 | RES CF 1/4W 220R J | PC | 1,000 | R582 | | | | |
| 180 | V30000712 | RES CF 1/4W 470R J | PC | 1,000 | R546 | | | | |
| 181 | V30000792 | RES CF 1/4W 75R J | PC | 4,000 | R563 | R556 | R557 | R558 | |
| 182 | V30001231 | RES FUSE 1/4W 27R J | PC | 1,000 | R613 | | | | |

BILL OF MATERIAL LIST

10016277

3241 TOSHIBA TOSHIBA 32WH37G(AK41)SILVER

| NO | PART NUMBER | DESCRIPTION | UNIT | QTY | POSITION NUMBER | | | | |
|-----|-------------|-----------------------------------|------|--------|-----------------|------|------|------|------|
| 183 | V30001284 | DIODE 1N4148 0.15A/100V 0.5A | PC | 1,000 | D502 | | | | |
| 184 | V30001349 | DIODE ZENER 11V | PC | 1,000 | IC504 | | | | |
| 185 | V30001369 | DIODE ZENER 3.6V ZPD | PC | 1,000 | D501 | | | | |
| 186 | V30001996 | FIXED COIL 22UH Q40 K | PC | 11,000 | L501 | L502 | L517 | L507 | L508 |
| | | | | | L509 | L510 | L513 | L514 | L515 |
| | | | | | L516 | | | | |
| 187 | V30017302 | PCB 11ST41-4 | PC | 1,000 | | | | | |
| 188 | V30000074 | CAP MKT 100NF 63V J | PC | 5,000 | C560 | C566 | C567 | C569 | C576 |
| 189 | V30000092 | CAP MKT 220NF 63V J | PC | 6,000 | C582 | C585 | C586 | C587 | C592 |
| | | | | | C620 | | | | |
| 190 | V30000109 | CAP MKT 470NF 63V J | PC | 6,000 | C522 | C523 | C524 | C525 | C527 |
| | | | | | C528 | | | | |
| 191 | V30000345 | CAP EL 10UF 50V M | PC | 3,000 | C531 | C532 | C533 | | |
| 192 | V30000352 | CAP EL 100UF 16V M | PC | 2,000 | C504 | C556 | | | |
| 193 | V30000371 | CAP EL 22UF 50V M | PC | 6,000 | C516 | C521 | C623 | C624 | C645 |
| | | | | | C646 | | | | |
| 194 | V30000393 | CAP EL 3.3UF 50V M | PC | 1,000 | C530 | | | | |
| 195 | V30000407 | CAP EL 470UF 16V M | PC | 4,000 | C501 | C505 | C551 | C552 | |
| 196 | V30000204 | CAP SMD 150PF 50V J 0805 | PC | 5,000 | C553 | C554 | C583 | C584 | C612 |
| 197 | V30000216 | CAP SMD 1.8PF 50V J CH (0805) | PC | 2,000 | C536 | C537 | | | |
| 198 | V30000232 | CAP SMD 270PF 50V J (0805) | PC | 1,000 | C635 | | | | |
| 199 | V30000237 | CAP SMD 33PF 50V J (0805) | PC | 5,000 | C631 | C632 | C633 | C634 | C637 |
| 200 | V30000247 | CAP SMD 39PF 50V J (0805) | PC | 2,000 | C561 | C562 | | | |
| 201 | V30000252 | CAP SMD 47PF 50V J (0805) | PC | 2,000 | C509 | C510 | | | |
| 202 | V30000256 | CAP SMD 470PF 50V J (0805) | PC | 1,000 | C636 | | | | |
| 203 | V30000263 | CAP SMD 56PF 50V J CH (0805) | PC | 1,000 | C542 | | | | |
| 204 | V30000265 | CAP SMD 560PF 50V J (0805) | PC | 1,000 | C526 | | | | |
| 205 | V30000284 | CAP SMD 1NF 50V K R (0805) | PC | 1,000 | C615 | | | | |
| 206 | V30000284 | CAP SMD 1NF 50V K R (0805) | PC | 12,000 | C507 | C508 | C534 | C535 | C538 |
| | | | | | C539 | C540 | C541 | C545 | C546 |
| | | | | | C547 | C548 | | | |
| 207 | V30000289 | CAP SMD 10NF 50V K R (0805) | PC | 1,000 | C638 | | | | |
| 208 | V30000294 | CAP SMD 100NF 50V K (0805) | PC | 16,000 | C502 | C517 | C529 | C543 | C544 |
| | | | | | C618 | C616 | C617 | C619 | C614 |
| | | | | | C630 | C563 | C643 | C644 | C549 |
| | | | | | C550 | | | | |
| 209 | V30000332 | CAP SMD 4.7NF 50V K (0805) | PC | 10,000 | C511 | C512 | C513 | C514 | C557 |
| | | | | | C558 | C564 | C565 | C590 | C591 |
| 210 | V30000457 | RES SMD 1/10W 10R J 0805 | PC | 6,000 | R538 | R540 | R559 | R595 | R589 |
| | | | | | R591 | | | | |
| 211 | V30000464 | RES SMD 1/10W 100R J | PC | 12,000 | R505 | R508 | R509 | R510 | R511 |
| | | | | | R592 | R615 | R616 | R617 | R618 |
| | | | | | R619 | R620 | | | |
| 212 | V30000469 | RES SMD 1/10W 1K J 0805 | PC | 10,000 | R512 | R516 | R517 | R519 | R520 |
| | | | | | R590 | R593 | R587 | R594 | R588 |
| 213 | V30000475 | RES SMD 1/10W 10K J 0805 | PC | 9,000 | R501 | R502 | R561 | R542 | R545 |
| | | | | | R547 | R549 | R597 | R600 | |
| 214 | V30000480 | RES SMD 1/10W 100K J (0805) | PC | 2,000 | R577 | R578 | | | |
| 215 | V30000503 | RES SMD 1/10W 12K J (0805) | PC | 2,000 | R583 | R585 | | | |
| 216 | V30000588 | RES SMD 1/10W 220R J 0805 | PC | 2,000 | R580 | R581 | | | |
| 217 | V30000626 | RES SMD 1/10W 270R J | PC | 1,000 | R507 | | | | |
| 218 | V30000636 | RES SMD 1/10W 27K J 0805 | PC | 2,000 | R584 | R586 | | | |
| 219 | V30000717 | RES SMD 1/10W 470R J (0805) | PC | 5,000 | R541 | R544 | R548 | R560 | R596 |
| 220 | V30000721 | RES SMD 1/10W 4.7K J | PC | 7,000 | R506 | R543 | R550 | R551 | R553 |
| | | | | | R562 | R598 | | | |
| 221 | V30000797 | RES SMD 1/10W 75R J (0805) | PC | 8,000 | R524 | R525 | R536 | R555 | R576 |
| | | | | | R579 | R599 | R529 | | |
| 222 | V30001285 | DIODE 1N4148 SMD | PC | 2,000 | D504 | D505 | | | |
| 223 | V30001457 | TR BC848B SMD | PC | 10,000 | Q506 | Q507 | Q508 | Q509 | Q510 |
| | | | | | Q511 | Q513 | Q512 | Q514 | Q515 |
| 224 | V30001458 | TR BC858B SMD | PC | 1,000 | Q501 | | | | |
| 226 | V30010964 | FERRITE BEAD(805) BLM21A601RPT | PC | 2,000 | L536 | L537 | | | |
| 227 | V30013413 | FERRITE BEAD ACB2012H-300 | PC | 13,000 | L535 | L520 | L521 | L522 | L523 |
| | | | | | L524 | L525 | L526 | L527 | L538 |
| | | | | | L539 | L540 | L541 | | |
| 228 | V20077209 | MD.SMD.ST41-HEADPHONE | PC | 1,000 | | | | | |
| 232 | V30000718 | RES CF 1/4W 4.7K J | PC | 2,000 | R527 | R531 | | | |
| 233 | V30001996 | FIXED COIL 22UH Q40 K | PC | 2,000 | L518 | L519 | | | |
| 234 | V30000074 | CAP MKT 100NF 63V J | PC | 1,000 | C571 | | | | |
| 235 | V30000100 | CAP MKT 330NF 63V J | PC | 2,000 | C555 | C559 | | | |
| 236 | V30000352 | CAP EL 100UF 16V M | PC | 2,000 | C574 | C578 | | | |
| 237 | V30000362 | CAP EL 1UF 50V M | PC | 1,000 | C579 | | | | |
| 238 | V30000407 | CAP EL 470UF 16V M | PC | 1,000 | C570 | | | | |
| 239 | V30000284 | CAP SMD 1NF 50V K R (0805) | PC | 4,000 | C503 | C506 | C581 | C575 | |
| 240 | V30000309 | CAP SMD 2.2NF 50V K R 0805 | PC | 2,000 | C573 | C580 | | | |
| 241 | V30000332 | CAP SMD 4.7NF 50V K (0805) | PC | 2,000 | C642 | C639 | | | |
| 242 | V30000475 | RES SMD 1/10W 10K J 0805 | PC | 2,000 | R530 | R554 | | | |
| 243 | V30000727 | RES SMD 1/10W 47K J (0805) | PC | 2,000 | R534 | R537 | | | |
| 244 | V30013413 | FERRITE BEAD ACB2012H-300 | PC | 2,000 | L528 | L529 | | | |
| 245 | V20077224 | MD.SMD.ST41-FAV | PC | 1,000 | | | | | |
| 246 | V30000332 | CAP SMD 4.7NF 50V K (0805) | PC | 2,000 | C640 | C641 | | | |
| 247 | V30013413 | FERRITE BEAD ACB2012H-300 | PC | 2,000 | L533 | L534 | | | |
| 248 | V20077226 | MD.SMD.ST41-BACK AV | PC | 1,000 | | | | | |
| 249 | V30013413 | FERRITE BEAD ACB2012H-300 | PC | 3,000 | L530 | L531 | L532 | | |
| 250 | V20082384 | MD.SMD.ST41-W/JVC | PC | 1,000 | | | | | |
| 255 | V30000797 | RES SMD 1/10W 75R J (0805) | PC | 1,000 | R614 | | | | |
| 257 | V20090584 | CHASSIS FRAME 288X (AK33)(V.0) | PC | 1,000 | | | | | |
| 258 | V60000009 | FR-HIPS NATR.V-0 | KG | 0.350 | | | | | |
| 259 | V35005061 | SCREW RB C SK ZN YFMB 2.9*9.5 | PC | 1,000 | | | | | |
| 262 | V20079177 | HE.ASY.41-SOUND WO/DOLBY | PC | 1,000 | | | | | |
| 263 | V30007794 | IC AAMP TDA7265 2*25W MULTIWATT11 | PC | 1,000 | IC802 | | | | |
| 264 | V35000158 | NUT C ZN BOTTOM M3 | PC | 1,000 | | | | | |
| 265 | V35000165 | KNURL WASHER C ZNSY 3*6*04 (M3) | PC | 1,000 | | | | | |
| 266 | V35000182 | SCREW C ZN YSMB M3*10 | PC | 1,000 | | | | | |
| 267 | V35004441 | HEATSINK AUDIO (AK41) | PC | 1,000 | | | | | |

BILL OF MATERIAL LIST

10016277

3241 TOSHIBA TOSHIBA 32WH37G(AK41)SILVER

| NO | PART NUMBER | DESCRIPTION | UNIT | QTY | POSITION NUMBER |
|-----|-------------|---|------|-------|-------------------------|
| 268 | V70000074 | SILICON (GRES) | KG | 0,001 | . |
| 269 | V40006901 | SPACER SUPPORT (TCBS-29) | PC | 1,000 | . |
| 271 | V20030940 | HE.ASY.28-REG WO/DVD (28-41) | PC | 1,000 | . |
| 272 | V30001302 | DIODE BYW29-200 8A/200V 80A | PC | 3,000 | D112 D114 |
| 273 | V30007802 | TR STP20N06LFP | PC | 2,000 | Q103 Q106 |
| 274 | V35000158 | NUT C ZN BOTTOM M3 | PC | 5,000 | . |
| 275 | V35000165 | KNURL WASHER C ZNSY 3*6*04 (M3) | PC | 5,000 | . |
| 276 | V35000182 | SCREW C ZN YSMB M3*10 | PC | 5,000 | . |
| 277 | V35002240 | HEATSINK REGULATOR (AK28) | PC | 1,000 | . |
| 279 | V30009637 | TUNER WSP (PLL) 38.9 MK2 - BATCH | PC | 1,000 | TU401 |
| 281 | V20000849 | FUSE ASSY.TK79-A (3.15A) | PC | 1,000 | F101 |
| 282 | V30001732 | FUSE 3.15A 250V 5*20 | PC | 1,000 | . |
| 283 | V35000138 | FUSE HOLDER TK79A (BLACK) | PC | 1,000 | . |
| 284 | V20043480 | HE.ASY.28-8V (28-41) | PC | 1,000 | . |
| 285 | V30001500 | IC LM7808 | PC | 1,000 | IC105 |
| 286 | V35000142 | HEATSINK 15AK14/15 15/TP ORTAK | PC | 1,000 | . |
| 287 | V35000158 | NUT C ZN BOTTOM M3 | PC | 1,000 | . |
| 288 | V35000165 | KNURL WASHER C ZNSY 3*6*04 (M3) | PC | 1,000 | . |
| 289 | V35000182 | SCREW C ZN YSMB M3*10 | PC | 1,000 | . |
| 290 | V20075415 | HE.ASSY.41-LM317 (AK41/45) | PC | 1,000 | IC106 |
| 291 | V30001668 | IC LM317T | PC | 1,000 | . |
| 292 | V35000142 | HEATSINK 15AK14/15 15/TP ORTAK | PC | 1,000 | . |
| 293 | V35000158 | NUT C ZN BOTTOM M3 | PC | 1,000 | . |
| 294 | V35000165 | KNURL WASHER C ZNSY 3*6*04 (M3) | PC | 1,000 | . |
| 295 | V35000182 | SCREW C ZN YSMB M3*10 | PC | 1,000 | . |
| 296 | V20082099 | HE.ASY.41J-HOR | PC | 1,000 | . |
| 297 | V30007678 | DIODE GUC DTV32F1500A 6A/1500V 100A | PC | 1,000 | D206 |
| 298 | V30007768 | DIODE STTA506F 5A/600V 55A | PC | 1,000 | D207 |
| 299 | V30007799 | TR BDX53BF1 | PC | 1,000 | Q205 |
| 300 | V30016686 | TR 2SC5302 | PC | 1,000 | Q202 |
| 301 | V35000015 | SPRING TR.HOLDER (BIG) | PC | 1,000 | . |
| 302 | V35000158 | NUT C ZN BOTTOM M3 | PC | 3,000 | . |
| 303 | V35000165 | KNURL WASHER C ZNSY 3*6*04 (M3) | PC | 3,000 | . |
| 304 | V35000181 | SCREW C ZN YSMB M3*8 | PC | 1,000 | . |
| 305 | V35000182 | SCREW C ZN YSMB M3*10 | PC | 2,000 | . |
| 306 | V35004571 | HEATSINK HORIZANTEL AK41 | PC | 1,000 | . |
| 307 | V30000094 | CAP MKT 220NF 275V M AC | PC | 1,000 | C112 |
| 308 | V30000131 | CAP MKP 100NF 250V J | PC | 1,000 | C111 |
| 309 | V30000287 | CAP CER 10NF 50V K B | PC | 1,000 | CXX3 |
| 310 | V30000351 | CAP EL 10UF 350V M | PC | 1,000 | C223 |
| 311 | V30000356 | CAP EL 100UF 63V M | PC | 1,000 | C226 |
| 312 | V30000359 | CAP EL 1000UF 16V M | PC | 4,000 | C146 C225 C251 C147 |
| 313 | V30000360 | CAP EL 1000UF 25V M | PC | 3,000 | C140 C228 C254 |
| 314 | V30000406 | CAP EL 47UF 250V M (HR) 105° | PC | 1,000 | C216 |
| 315 | V30000409 | CAP EL 470UF 25V M | PC | 3,000 | C133 C804 C806 |
| 316 | V30000415 | CAP EL 4.7UF 250V M | PC | 1,000 | C208 |
| 317 | V30001041 | RES ADJ 1/6W 1K M VER | PC | 1,000 | VR127 |
| 318 | V30001077 | RES MO 2W 10R J | PC | 1,000 | R264 |
| 319 | V30001089 | RES MO 2W 1R J | PC | 1,000 | R156 |
| 320 | V30001134 | RES MO 2W 2.2R J | PC | 1,000 | R255 |
| 321 | V30001168 | RES MO 2W 470RJ | PC | 1,000 | R226 |
| 322 | V30001229 | RES FUSE 1W 2.2R J | PC | 1,000 | R231 |
| 323 | V30001265 | NTC MONITOR 10R/3A SCK-103 | PC | 1,000 | J412 |
| 324 | V30001299 | DIODE UF5404 3A/400V 150A | PC | 3,000 | D111 D210 D211 |
| 325 | V30001762 | CONN HEADER 2P 2.5MM(9.7MM) TOP | PC | 1,000 | PL802 |
| 326 | V30001764 | CONN HEADER 2P 2.5MM(9.7MM) TOP BLACK | PC | 1,000 | PL804 |
| 327 | V30001784 | CONN HEADER 6P 2.5MM TOP BD | PC | 1,000 | PL900 |
| 328 | V30001792 | CONN HEADER 2P 7.5MM TOP WHT | PC | 1,000 | PL204 |
| 329 | V30001792 | CONN HEADER 2P 7.5MM TOP WHT | PC | 1,000 | PL101 |
| 330 | V30001795 | CONN HEADER 3P 5/7.5MM TOP WHT | PC | 1,000 | PL102 |
| 331 | V30001810 | CONN HEADER 14P 2.5MM TOP WHT | PC | 1,000 | PL414 |
| 332 | V30001812 | CONN HEADER 15P 2.5MM TOP WHT | PC | 4,000 | PL330 PL331 PL332 PL415 |
| 333 | V30001829 | CONN HEADER 2P 2.5MM TOP WHT SD | PC | 1,000 | PL206 |
| 334 | V30001851 | CONN HEADER 7P 2.5MM TOP WHT | PC | 1,000 | PL202 |
| 335 | V30001853 | SOCKET IC 32P | PC | 1,000 | IC304 |
| 336 | V30001960 | FERIT BAR 6*20MM AK16 | PC | 3,000 | L107 L108 L109 |
| 338 | V30002183 | RELAY MON15 KI-S-212M | PC | 1,000 | RL2 |
| 340 | V30006662 | XTAL 6MHZ | PC | 1,000 | X900 |
| 341 | V30006712 | FERRITE BEAD 3.5X4.7X0.8 | PC | 1,000 | L106 |
| 342 | V30006743 | TRF. HORIZONTAL DRIVER 15AK17-17" | PC | 1,000 | TR201 |
| 343 | V30006744 | LINE FILTER 16MH 15AK17-17" | PC | 1,000 | L103 |
| 344 | V30006909 | CAP EL 100UF M 250V | PC | 1,000 | C131 |
| 345 | V30007442 | IC TDA16846 (4646) | PC | 1,000 | IC101 |
| 346 | V30007444 | IC L4931CV50 | PC | 1,000 | IC104 |
| 347 | V30007748 | CAP EL 1000UF 35V M | PC | 2,000 | C135 C136 |
| 348 | V30007750 | CAP EL 470UF 35V (H/R 1150MA) | PC | 2,000 | C132 C134 |
| 349 | V30007755 | CAP MKT 680NF 275V M AC X2 | PC | 1,000 | C118 |
| 350 | V30007757 | COIL INJECTION EW 6MH AK28 | PC | 1,000 | L202 |
| 351 | V30007758 | DIODE BRIDGE GBU4M 4A/1000V 150A | PC | 1,000 | D106 |
| 352 | V30007770 | FILTER COIL 1MH AK28 | PC | 1,000 | L203 |
| 353 | V30007771 | FIXED COIL 100UH | PC | 1,000 | L201 |
| 354 | V30007802 | TR STP20N06LFP | PC | 1,000 | Q201 |
| 355 | V30007858 | CAP MKT 470NF 275V M AC (P=22.5MM) | PC | 1,000 | C115 |
| 356 | V30009036 | RES FUSE 1/2W 0.1R J | PC | 1,000 | R234 |
| 357 | V30009036 | RES FUSE 1/2W 0.1R J | PC | 2,000 | R118 R119 |
| 358 | V30009037 | FUSE 6.3A 250V 5mm | PC | 2,000 | F102 F103 |
| 359 | V30009832 | CABL 1P/130 SIS | PC | 1,000 | CAB001 |
| 360 | V30012619 | CNAS 10P/500 RGB SHL W/DC UL1533AWG24 | PC | 1,000 | PL004 |
| 361 | V30013690 | CAP EL 220UF 450V M 105° | PC | 1,000 | C121 |
| 362 | V30015087 | IC OPTOCOUPLER TCET1102G | PC | 1,000 | IC102 |
| 363 | V30016591 | CNAS 5P-7/500 AK41 SIS W/DC UL1007AWG24 | PC | 1,000 | PL202 |
| 364 | V35000224 | SCREW C SK ZN YFMB 2.9*9.5 | PC | 1,000 | . |
| 365 | V35001859 | SHIELD CONTROLLER (MAIN BOARD-11AK28) | PC | 1,000 | . |
| 366 | V35002631 | SHIELD IF (MAIN BOARD-11AK28) | PC | 1,000 | . |
| 367 | V35005061 | SCREW RB C SK ZN YFMB 2.9*9.5 | PC | 3,000 | . |

BILL OF MATERIAL LIST

10016277

3241 TOSHIBA TOSHIBA 32WH37G(AK41)SILVER

| NO | PART NUMBER | DESCRIPTION | UNIT | QTY | POSITION NUMBER | | | | |
|-----|-------------|---------------------------------------|------|-------|-----------------|------|------|------|------|
| 368 | V40006431 | SPACER SUPPORT (SCC-10A) | PC | 1,000 | . | . | . | . | . |
| 369 | V40006432 | MOUNTING BUTTON (MB-10) | PC | 2,000 | . | . | . | . | . |
| 370 | V40006903 | HOLD PLUG COVER (BH-10) | PC | 1,000 | . | . | . | . | . |
| 371 | V40008183 | SPACER SUPPORT (SCC-10C) | PC | 1,000 | . | . | . | . | . |
| 372 | V70000029 | SOLDER (INGOT) 63/37 | KG | 0,019 | . | . | . | . | . |
| 373 | V70000030 | SOLDER WIRE CAP 1.00mm 60Sn40Pb | G | 1,200 | . | . | . | . | . |
| 375 | V20063054 | CN.ASY.28-DIODE BYM26D+FERIT+HEATSINK | PC | 1,000 | D110 | . | . | . | . |
| 376 | V30001301 | DIODE BYM26D 2.3A/800V 45-150A | PC | 1,000 | . | . | . | . | . |
| 377 | V30001964 | FERRITE BAR 5*8 | PC | 1,000 | . | . | . | . | . |
| 378 | V35003543 | HEATSINK DIODE (1) | PC | 2,000 | . | . | . | . | . |
| 379 | V20082157 | HE.ASY.41J-SMPS W/PFC | PC | 1,000 | . | . | . | . | . |
| 380 | V30007768 | DIODE STTA506F 5A/600V 55A | PC | 3,000 | D103 | D104 | D105 | . | . |
| 381 | V30007801 | TR SPP20N60S5 | PC | 1,000 | Q101 | . | . | . | . |
| 382 | V35000158 | NUT C ZN BOTTOM M3 | PC | 4,000 | . | . | . | . | . |
| 383 | V35000165 | KNURL WASHER C ZNSY 3*6*04 (M3) | PC | 4,000 | . | . | . | . | . |
| 384 | V35000182 | SCREW C ZN YSMB M3*10 | PC | 3,000 | . | . | . | . | . |
| 385 | V35000183 | SCREW C ZN YSMB M3*12 | PC | 1,000 | . | . | . | . | . |
| 386 | V35004184 | HEATSINK SMPS AK28-7 | PC | 1,000 | Q101 | . | . | . | . |
| 387 | V40000020 | TR HOLDER TR-06A | PC | 1,000 | . | . | . | . | . |
| 388 | V40000146 | INSULATOR SILICON PAD (15*20) | PC | 1,000 | . | . | . | . | . |
| 389 | V30000123 | CAP PP 33NF 630V K | PC | 1,000 | C108 | . | . | . | . |
| 390 | V30001171 | RES MO 2W 4.7K J | PC | 1,000 | R116 | . | . | . | . |
| 391 | V30006744 | LINE FILTER 16MH 15AK17-17" | PC | 1,000 | L104 | . | . | . | . |
| 392 | V30007753 | CAP MKP 1NF 1KV | PC | 1,000 | C120 | . | . | . | . |
| 393 | V30007754 | CAP MKP 1UF 400V | PC | 1,000 | C119 | . | . | . | . |
| 394 | V30007775 | COIL PFC 1MH 1KHZ 2A | PC | 1,000 | L102 | . | . | . | . |
| 396 | V30014023 | RES FUSE 1/2W 0.1R J VISHAY | PC | 2,000 | R148 | R151 | . | . | . |
| 397 | V30016819 | TRF SMPS AK41 W/PFC (J) | PC | 1,000 | TR101 | . | . | . | . |
| 398 | V30023449 | CAP MKP 4.7NF 2KV J | PC | 1,000 | C109 | . | . | . | . |
| 401 | V30001494 | IC TDA4470B | PC | 1,000 | IC401 | . | . | . | . |
| 402 | V30001692 | FILTER SAW OFWK3953M | PC | 1,000 | Z403 | . | . | . | . |
| 403 | V30001706 | FILTER SAW OFWK9453 | PC | 1,000 | Z401 | . | . | . | . |
| 404 | V30001726 | FILTER SER TRAP TPS 6.5MHZ | PC | 1,000 | T402 | . | . | . | . |
| 405 | V30001979 | FIXED COIL 1UH Q45 M-A | PC | 1,000 | LXX1 | . | . | . | . |
| 406 | V30002036 | ADJ COIL VIF 38.9MHZ C=12PF | PC | 1,000 | VL401 | . | . | . | . |
| 407 | V30009195 | CONN HEADER 1P TOP BLACK | PC | 1,000 | CXXX | . | . | . | . |
| 409 | V20043482 | HE.ASY.28-VER 28"-29"-32" (28-41) | PC | 1,000 | . | . | . | . | . |
| 410 | V30007793 | IC STV9379FA | PC | 1,000 | IC201 | . | . | . | . |
| 411 | V35000158 | NUT C ZN BOTTOM M3 | PC | 1,000 | . | . | . | . | . |
| 412 | V35000165 | KNURL WASHER C ZNSY 3*6*04 (M3) | PC | 1,000 | . | . | . | . | . |
| 413 | V35000183 | SCREW C ZN YSMB M3*12 | PC | 1,000 | . | . | . | . | . |
| 414 | V35002239 | HEATSINK VERTICAL (AK28) | PC | 1,000 | . | . | . | . | . |
| 415 | V40000020 | TR HOLDER TR-06A | PC | 1,000 | . | . | . | . | . |
| 416 | V40000146 | INSULATOR SILICON PAD (15*20) | PC | 1,000 | . | . | . | . | . |
| 417 | V30000447 | CAP CER 4.7NF 4KV M E | PC | 1,000 | C122 | . | . | . | . |
| 418 | V30001086 | RES MO 2W 10K J | PC | 1,000 | R225 | . | . | . | . |
| 419 | V30001270 | PTC 9 OHM | PC | 1,000 | R109 | . | . | . | . |
| 420 | V30007728 | CABLE 1P R2.6 50 W/CLIPS | PC | 1,000 | KXX1 | . | . | . | . |
| 421 | V20117602 | PR.IC.41-AK41J A(32*SF) | PC | 1,000 | . | . | . | . | . |
| 422 | V20118227 | PR.IC.41-AK41J A030 | PC | 1,000 | . | . | . | . | . |
| 423 | V30016491 | IC 27W401 | PC | 1,000 | IC304 | . | . | . | . |
| 426 | V30000717 | RES SMD 1/10W 470R J (0805) | PC | 2,000 | R809 | R811 | . | . | . |
| 428 | V30007021 | RES SMD 1/10W 1K F (0805) | PC | 1,000 | R137 | . | . | . | . |
| 429 | V30007786 | RES SMD 1/10W 2.55K F (0805) | PC | 1,000 | R138 | . | . | . | . |
| 436 | V30001291 | DIODE HER107 1A/800V 30A | PC | 1,000 | D102 | . | . | . | . |
| 437 | V30009208 | CAP CER 470PF 1KV K (PULSE) | PC | 3,000 | C110 | C163 | C167 | . | . |
| 438 | V30000469 | RES SMD 1/10W 1K J 0805 | PC | 1,000 | R122 | . | . | . | . |
| 439 | V30000575 | RES SMD 1/10W 2K J | PC | 1,000 | S133 | . | . | . | . |
| 440 | V30000664 | RES SMD 1/10W 3.3K J (0805) | PC | 1,000 | R106 | . | . | . | . |
| 448 | V30000082 | CAP MKT 15NF 63V J | PC | 1,000 | C100 | . | . | . | . |
| 449 | V30000224 | CAP SMD 220PF 50V J (0805) | PC | 1,000 | C209 | . | . | . | . |
| 450 | V30000315 | CAP SMD 220NF 25V Z (0805) | PC | 1,000 | C206 | . | . | . | . |
| 451 | V30000325 | CAP SMD 33NF 50V K (0805) | PC | 1,000 | C137 | . | . | . | . |
| 452 | V30000506 | RES SMD 1/10W 120K J | PC | 1,000 | R218 | . | . | . | . |
| 453 | V30000732 | RES SMD 1/10W 470K J | PC | 1,000 | R145 | . | . | . | . |
| 454 | V30007021 | RES SMD 1/10W 1K F (0805) | PC | 1,000 | R120 | . | . | . | . |
| 461 | V30000503 | RES SMD 1/10W 12K J (0805) | PC | 1,000 | R492 | . | . | . | . |
| 462 | V30000751 | RES SMD 1/10W 5.6K J 0805 | PC | 1,000 | R441 | . | . | . | . |
| 463 | V30012692 | RES SMD 1/16W 4.7K J (0603) | PC | 1,000 | R934 | . | . | . | . |
| 465 | V30000464 | RES SMD 1/10W 100R J | PC | 1,000 | R942 | . | . | . | . |
| 473 | V30000452 | RES CF 1/4W 10R J | PC | 1,000 | R105 | . | . | . | . |
| 474 | V30000459 | RES CF 1/4W 100R J | PC | 3,000 | R140 | R323 | R937 | . | . |
| 475 | V30000466 | RES CF 1/4W 1K J | PC | 4,000 | R490 | R245 | R959 | R953 | . |
| 476 | V30000471 | RES CF 1/4W 10K J | PC | 6,000 | R912 | R915 | R945 | R914 | R943 |
| | | | | | R960 | . | . | . | . |
| 477 | V30000477 | RES CF 1/4W 100K J | PC | 2,000 | R250 | R251 | . | . | . |
| 478 | V30000500 | RES CF 1/4W 12K J | PC | 1,000 | R940 | . | . | . | . |
| 479 | V30000531 | RES CF 1/4W 15K J | PC | 3,000 | R806 | R909 | R910 | . | . |
| 480 | V30000536 | RES CF 1/4W 150K J | PC | 1,000 | R128 | . | . | . | . |
| 481 | V30000541 | RES CF 1/4W 1.5M J | PC | 1,000 | R270 | . | . | . | . |
| 482 | V30000564 | RES CF 1/4W 18K J | PC | 1,000 | R810 | . | . | . | . |
| 483 | V30000583 | RES CF 1/4W 220R J | PC | 1,000 | R210 | . | . | . | . |
| 484 | V30000590 | RES CF 1/4W 2.2K J | PC | 1,000 | R220 | . | . | . | . |
| 485 | V30000594 | RES CF 1/4W 22K J | PC | 1,000 | R322 | . | . | . | . |
| 486 | V30000628 | RES CF 1/4W 2.7K J | PC | 1,000 | R803 | . | . | . | . |
| 487 | V30000712 | RES CF 1/4W 470R J | PC | 1,000 | R155 | . | . | . | . |
| 488 | V30000718 | RES CF 1/4W 4.7K J | PC | 9,000 | R236 | R801 | R480 | R802 | R903 |
| | | | | | R933 | R904 | R936 | R961 | . |
| 489 | V30000729 | RES CF 1/4W 470K J | PC | 1,000 | R238 | . | . | . | . |
| 490 | V30000734 | RES CF 1/4W 4.7R J | PC | 4,000 | R812 | R808 | R819 | R820 | . |
| 491 | V30000744 | RES CF 1/4W 560R J | PC | 1,000 | R271 | . | . | . | . |
| 492 | V30000784 | RES CF 1/4W 680K J | PC | 1,000 | R242 | . | . | . | . |
| 493 | V30000855 | RES MF 1/4W 1M F | PC | 1,000 | R103 | . | . | . | . |
| 494 | V30000902 | RES MF 1/4W 1.8K F | PC | 1,000 | R230 | . | . | . | . |
| 495 | V30000927 | RES MF 1/4W 220K J | PC | 1,000 | R125 | . | . | . | . |

BILL OF MATERIAL LIST

10016277

3241 TOSHIBA TOSHIBA 32WH37G(AK41)SILVER

| NO | PART NUMBER | DESCRIPTION | UNIT | QTY | POSITION NUMBER |
|-----|-------------|--|------|-------|-------------------------------|
| 666 | V30001237 | RES FUSE 1/2W 3.3R J | PC | 1,000 | R262 |
| 667 | V30001244 | RES FUSE 1/2W 0.47R J | PC | 2,000 | R233 R237 |
| 668 | V30001253 | RES FUSE 1W 0.56R J | PC | 1,000 | R239 |
| 670 | V30012271 | LINEARTY COIL 4.3UH VOGT | PC | 1,000 | L204 |
| 671 | V30013003 | CAP MKP 1UF 250V J P=15 | PC | 1,000 | C213 |
| 672 | V30015222 | RES MO 1W 0.75R J | PC | 1,000 | R257 |
| 673 | V30017521 | TRF FBT SINGLE COMMON FOCUS LAYER (AK41) | PC | 1,000 | TR202 |
| 674 | V30018581 | RES MO 2W 150R J | PC | 1,000 | R202 |
| 675 | V30019483 | COIL BRIDGE 300UH 32KHZ AK52 | PC | 1,000 | L205 |
| 676 | V40006432 | MOUNTING BUTTON (MB-10) | PC | 2,000 | |
| 677 | V20107951 | MD.ASY.SB103-FAV+HP XX41/W (AK41) | PC | 1,000 | |
| 680 | V30001830 | CONN HEADER 2P 2.5MM TOP BLUE SD | PC | 1,000 | PL106 |
| 681 | V30001839 | CONN HEADER 3P 2.5MM TOP GREEN SD | PC | 1,000 | PL107 |
| 682 | V30001891 | RCA JACK 1P WHITE 28 FAV | PC | 1,000 | JK102 |
| 683 | V30001892 | RCA JACK 1P RED 28 FAV | PC | 1,000 | JK103 |
| 684 | V30001893 | RCA JACK 1P YELLOW 28 FAV | PC | 1,000 | JK101 |
| 686 | V30001902 | JACK HEADPHONE STEREO WO/SW | PC | 1,000 | JK108 |
| 687 | V30013231 | CNAS 3P/900 FLT W/C UL2468AWG24 | PC | 1,000 | PL108 |
| 689 | V30002362 | CNAS 830 FAV SHL W/4C+FER | PC | 1,000 | PL106, PL107 |
| 696 | V30000594 | RES CF 1/4W 22K J | PC | 2,000 | R102 R104 |
| 697 | V30000712 | RES CF 1/4W 470R J | PC | 2,000 | R103 R106 |
| 698 | V30001979 | FIXED COIL 1UH Q45 M-A | PC | 1,000 | L101 |
| 699 | V30019363 | PCB 11SB103-2 | PC | 1,000 | |
| 700 | V30000190 | CAP CER 100PF 50V J CH | PC | 3,000 | C101 C103 C104 |
| 704 | V30000460 | RES CF 1/4W 100R G | PC | 2,000 | R112 R113 |
| 705 | V30000471 | RES CF 1/4W 10K J | PC | 2,000 | R114 R115 |
| 706 | V30001996 | FIXED COIL 22UH Q40 K | PC | 2,000 | L103 L104 |
| 707 | V30000290 | CAP CER 10NF 50V Z F | PC | 2,000 | C105 C106 |
| 708 | V20110652 | ARTWORK TOSH.TOSHIBA 32WH37G(AK41)SILVER | PC | 1,000 | |
| 709 | V20100980 | R/C 2143 TOSHIBA CT-841(SILVER/P)(GRAY/S | PC | 1,000 | |
| 710 | V20096229 | R/C 2143 NOBRAND SILVER (F) | PC | 1,000 | |
| 711 | V20094768 | R/C KIT 2143 TOSHIBA | PC | 1,000 | |
| 712 | V20094767 | MD.ASY.UK05 | PC | 1,000 | |
| 713 | V20094766 | UKV.B.ASSY.UK05 (SMD) | PC | 1,000 | |
| 714 | V30000489 | RES SMD 1/10W 1R J (0805) | PC | 1,000 | R102 |
| 715 | V30012509 | RES SMD 1/16W 100K J (0603) | PC | 1,000 | R103 |
| 716 | V30012510 | RES SMD 1/16W 100R J (0603) | PC | 1,000 | R100 |
| 717 | V30012578 | CAP SMD 68PF 50V J (0603) | PC | 2,000 | C101 C102 |
| 718 | V30016654 | CAP SMD 100NF 16V K R (0603) | PC | 2,000 | C103 C104 |
| 719 | V30018063 | IC HT48RA0A OTP | PC | 1,000 | IC101 |
| 720 | V30018712 | PCB 11UK05-2 | PC | 1,000 | |
| 721 | V30000352 | CAP EL 100UF 16V M | PC | 1,000 | C100 |
| 722 | V30001453 | TR BC337 | PC | 1,000 | Q100 |
| 723 | V30002733 | LED INFRARED IR333 | PC | 1,000 | D100 |
| 724 | V30002852 | XTAL REZ 455KHZ | PC | 1,000 | X100 |
| 725 | V35002401 | BATTERY CONT.SINGLE (-) RC2040 | PC | 1,000 | |
| 726 | V35005008 | BATTERY CONT.SINGLE (+) RC2040 TOSHIBA | PC | 1,000 | |
| 727 | V35000228 | SCREW SK C ZNSY YSMB 2.9*9.5 | PC | 1,000 | |
| 728 | V35005007 | DOUBLE BATTERY CONTACT UKV-900 TOSHIBA | PC | 1,000 | |
| 729 | V40005467 | LENS RC2040(I) | PC | 1,000 | |
| 730 | V40010082 | RUBBER PAD TRP41 (RC 2143) TOSHIBA | PC | 1,000 | |
| 731 | V40012344 | SPONGE (BATTERY DOOR) (15x31x5mm) | PC | 1,000 | |
| 732 | V40005299 | BATTERY COVER RC2040 SILVER(P) | PC | 1,000 | |
| 733 | V40009346 | BOTTOM CVR R/C 21/2240 SILVER(P) | PC | 1,000 | |
| 734 | V40010357 | TOP CVR R/C 2143 NOBRAND (S) SILVER(P) | PC | 1,000 | |
| 735 | V30002391 | BATTERY AAA UM4 1.5V GREEN | PC | 2,000 | |
| 736 | V50031553 | I/B TOSHIBA 32WH37G P/5550/2143/GESIFP | PC | 1,000 | |
| 737 | V20110654 | LBL.BCK.CVR.TOSHIBA TOSHIBA 32WH37G "41" | PC | 1,000 | |
| 738 | V20013018 | LBL.BCK.CVR.ASSY (TV) (WO/UL) | PC | 1,000 | |
| 739 | V50023173 | LABEL LOT W/BARCODE (77X256) | PC | 1,050 | |
| 740 | V70000621 | RIBBON 80MM*450MM | PC | 1,030 | |
| 741 | V20110655 | LBL.CART.BOX TOSHIBA 32WH37G(ÇYFT KATLI) | PC | 1,000 | |
| 742 | V50023532 | LABEL LOT TOSHIBA ÇYFT KATLI | PC | 1,050 | |
| 743 | V70000621 | RIBBON 80MM*450MM | PC | 1,050 | |
| 744 | V20114691 | EXP.KIT AK37 324XW V.0 | PC | 1,000 | |
| 745 | V20004520 | CABLE HOLDER DX15 (I) | PC | 1,000 | |
| 746 | V60000991 | KIRMA - HDPE | KG | 0,003 | |
| 747 | V20084045 | STRAP TIE (L:118) | PC | 1,000 | |
| 748 | V60000018 | COPOLYMER POLYPROPYLENE | KG | 0,001 | |
| 749 | V20085269 | CABLE HOLDER CRT (I) UL94V-0 | PC | 2,000 | |
| 750 | V60000855 | KIRMA FR-ABS BLUE CRT | KG | 0,002 | |
| 751 | V40006731 | ISOLATION COTTON (9x25000mm) | M | 2,000 | |
| 752 | V50006325 | CARTON SEPERATOR 665x980x6.5 (8270/71) | PC | 2,000 | |
| 753 | V70000331 | ADHESIVE TAPE 75MM/660M (4125) | M | 2,592 | |
| 754 | V20116298 | CRT B.ASSY.TP41J-28"32"33"W/BSVM(DARFON | PC | 1,000 | |
| 756 | V20079543 | CRT B.ASSY.TP41J-COMMON (SMD) | PC | 1,000 | |
| 761 | V20079548 | CRT B.ASSY.TP41J-COMMON (PER) | PC | 1,000 | |
| 762 | V35000176 | EYELET BR 2*3MM | PC | 2,000 | PL905 PL906 |
| 764 | V30000428 | SPARK GAP 300V | PC | 5,000 | SP901 SP903 SP904 SP905 SP906 |
| 765 | V30000466 | RES CF 1/4W 1K J | PC | 1,000 | R929 |
| 766 | V30000471 | RES CF 1/4W 10K J | PC | 1,000 | R932 |
| 767 | V30000477 | RES CF 1/4W 100K J | PC | 3,000 | R922 R923 R924 |
| 768 | V30000535 | RES CF 1/2W 150K J | PC | 1,000 | R920 |
| 769 | V30000788 | RES CF 1/4W 6.8M J | PC | 1,000 | R918 |
| 770 | V30001284 | DIODE 1N4148 0.15A/100V 0.5A | PC | 1,000 | D907 |
| 771 | V30001291 | DIODE HER107 1A/800V 30A | PC | 1,000 | D908 |
| 772 | V30001318 | DIODE BA159 1A/800V 20A | PC | 1,000 | D902 |
| 773 | V30001347 | DIODE ZENER 8.2V | PC | 1,000 | SP902 |
| 774 | V30001353 | DIODE ZENER 18V | PC | 1,000 | D909 |
| 775 | V30001992 | FIXED COIL 10UH Q65 K-A | PC | 2,000 | J909 L906 |
| 777 | V30001997 | FIXED COIL 33UH Q60 J | PC | 1,000 | L904 |
| 778 | V30006712 | FERRITE BEAD 3.5X4.7X0.8 | PC | 1,000 | J907 |
| 779 | V30020924 | PCB 11TP41J-3 | PC | 1,000 | |
| 780 | V30000202 | CAP CER 15PF 50V J CH | PC | 1,000 | C901 |
| 781 | V30000295 | CAP CER 100NF 50V Z F | PC | 1,000 | C941 |

BILL OF MATERIAL LIST

10016277

3241 TOSHIBA TOSHIBA 32WH37G(AK41)SILVER

| NO | PART NUMBER | DESCRIPTION | UNIT | QTY | POSITION NUMBER | | | | | |
|-----|-------------|---|------|-------|-----------------|-------|-------|------|------|---|
| 782 | V30000330 | CAP CER 4.7NF 50V K B | PC | 1,000 | C916 | . | . | . | . | . |
| 783 | V30000352 | CAP EL 100UF 16V M | PC | 1,000 | C919 | . | . | . | . | . |
| 784 | V30000433 | CAP CER 1NF 1KV M B | PC | 1,000 | C938 | . | . | . | . | . |
| 785 | V30000436 | CAP CER 10NF 1KV ZE | PC | 1,000 | C942 | . | . | . | . | . |
| 786 | V30001427 | TR BF422 | PC | 1,000 | Q901 | . | . | . | . | . |
| 787 | V30001455 | TR BC558B | PC | 1,000 | Q902 | . | . | . | . | . |
| 788 | V30000209 | CAP SMD 18PF 50V J (0805) | PC | 1,000 | C905 | . | . | . | . | . |
| 789 | V30000220 | CAP SMD 22PF 50V J (0805) | PC | 1,000 | C909 | . | . | . | . | . |
| 790 | V30000265 | CAP SMD 560PF 50V J (0805) | PC | 4,000 | C904 | C908 | C912 | C931 | . | . |
| 791 | V30000294 | CAP SMD 100NF 50V K (0805) | PC | 7,000 | C902 | C906 | C910 | C920 | C934 | . |
| | | | | | C935 | C949 | . | . | . | . |
| 792 | V30000469 | RES SMD 1/10W 1K J 0805 | PC | 1,000 | R926 | . | . | . | . | . |
| 793 | V30000499 | RES SMD 1/10W 1.2K J (0805) | PC | 6,000 | R901 | R903 | R906 | R908 | R911 | . |
| | | | | | R913 | . | . | . | . | . |
| 794 | V30000524 | RES SMD 1/10W 150R J (0805) | PC | 3,000 | R904 | R909 | R914 | . | . | . |
| 795 | V30000593 | RES SMD 1/10W 2.2K J (0805) | PC | 1,000 | R931 | . | . | . | . | . |
| 796 | V30007788 | RES SMD 1/10W 2.7K F (0805) | PC | 1,000 | R925 | . | . | . | . | . |
| 798 | V20000989 | HE.ASY.TP18-RGB | PC | 3,000 | IC901 | IC903 | IC902 | . | . | . |
| 799 | V30001551 | IC TDA6111Q | PC | 1,000 | . | . | . | . | . | . |
| 800 | V35000131 | HEATSINK 11TP18 RGB | PC | 1,000 | . | . | . | . | . | . |
| 801 | V35000158 | NUT C ZN BOTTOM M3 | PC | 1,000 | . | . | . | . | . | . |
| 802 | V35000165 | KNURL WASHER C ZNSY 3*6*04 (M3) | PC | 1,000 | . | . | . | . | . | . |
| 803 | V35000189 | SCREW C NI YSMB M3*6 | PC | 1,000 | . | . | . | . | . | . |
| 804 | V30000072 | CAP MKT 10NF 1250V J | PC | 1,000 | C914 | . | . | . | . | . |
| 805 | V30000075 | CAP MKT 100NF 250V K (DC) | PC | 5,000 | C903 | C907 | C911 | C922 | C936 | . |
| 806 | V30000406 | CAP EL 47UF 250V M (HR) 105° | PC | 1,000 | C923 | . | . | . | . | . |
| 807 | V30000415 | CAP EL 4.7UF 250V M | PC | 1,000 | C915 | . | . | . | . | . |
| 808 | V30001084 | RES MO 1W 1K J | PC | 3,000 | R905 | R910 | R915 | . | . | . |
| 809 | V30001125 | RES MO 2W 2.2K J | PC | 1,000 | R916 | . | . | . | . | . |
| 810 | V30001170 | RES MO 1W 4.7K J | PC | 1,000 | R917 | . | . | . | . | . |
| 811 | V30001211 | RES FUSE 1W 1K J | PC | 1,000 | R944 | . | . | . | . | . |
| 812 | V30001249 | RES FUSE 1W 4.7R J | PC | 1,000 | R927 | . | . | . | . | . |
| 813 | V30001851 | CONN HEADER 7P 2.5MM TOP WHT | PC | 1,000 | PL902 | . | . | . | . | . |
| 814 | V30001855 | SOCKET CRT NARROWNECK W/GND | PC | 1,000 | PL904 | . | . | . | . | . |
| 816 | V30002876 | CNAS 1P/250 EMC DIS W/TER | PC | 1,000 | . | . | . | . | . | . |
| 817 | V30012894 | CONN HEADER 10P 2.54MM TOP WHT | PC | 1,000 | PL901 | . | . | . | . | . |
| 818 | V30017132 | RES MF 1W 51K F | PC | 3,000 | R902 | R907 | R912 | . | . | . |
| 819 | V35000135 | TEST PIN 1.1MM | PC | 1,000 | PL905 | . | . | . | . | . |
| 820 | V35000512 | NUT C ZN M4 | PC | 1,000 | . | . | . | . | . | . |
| 821 | V30011622 | 32*SF 100HZ CPT TUBE | PC | 1,000 | . | . | . | . | . | . |
| 822 | V40012621 | LOGO TOSHIBA (W/P-SILVER BR/H.ST)(GRAY) | PC | 1,000 | . | . | . | . | . | . |
| 823 | V50000007 | PLASTIZOTE (1400*1000) | PC | 2,000 | . | . | . | . | . | . |
| 824 | V50000040 | LABEL SCREEN 100HZ (GÖZ) | PC | 1,000 | . | . | . | . | . | . |
| 825 | V50027594 | LABEL EHT/29.8KV BEAM/1700UA (GER) | PC | 1,000 | . | . | . | . | . | . |
| 826 | V50029320 | LABEL SCR.100HZ FASTEXT(AK41-AK52)(2SC) | PC | 1,000 | . | . | . | . | . | . |

Cabinet Exploded View

N/A

TOSHIBA Information Systems (UK) Ltd
Consumer Products Division, European Service Centre, Admiralty Way, Camberley, Surrey. GU15 3DT