

### DESCRIPTION

The 3858 group is the 8-bit microcomputer based on the 740 family core technology.

The 3858 group is designed for the household products and office automation equipment and includes serial interface functions, 8-bit timer, 16-bit timer, and A/D converter.

### FEATURES

- Basic machine-language instructions ..... 71
- Minimum instruction execution time ..... 0.32 μs  
(at 12.5 MHz oscillation frequency)
- Memory size
  - ROM ..... 48 K bytes
  - RAM ..... 1.5 K bytes
- Programmable input/output ports ..... 34
- On-chip software pull-up resistor ..... Built-in
- Interrupts ..... 19 sources, 16 vectors  
(external 8, internal 10, software 1)
- Timers ..... 8-bit X 4  
..... 16-bit X 2
- Serial interface
  - Serial I/O1 ..... 8-bit X 1 (UART or Clock-synchronized)
  - Serial I/O2 ..... 8-bit X 1 (Clock-synchronized)
- PWM ..... 8-bit X 1
- A/D converter ..... 8-bit X 9 channels

- Clock generating circuit ..... Built-in 2 circuits  
(connect to external ceramic resonator or quartz-crystal oscillator)
- Watchdog timer ..... 16-bit X 1
- Power source voltage
  - In high-speed mode ..... 4.0 to 5.5 V  
(at 12.5 MHz oscillation frequency)
  - In high-speed mode ..... 2.7 to 5.5 V  
(at 6 MHz oscillation frequency)
  - In middle-speed mode ..... 2.7 to 5.5 V  
(at 12.5 MHz oscillation frequency, at middle-speed mode)
  - In low-speed mode ..... 2.7 to 5.5 V  
(at 32 kHz oscillation frequency)
- Operating temperature range ..... -20 to 85°C

### APPLICATION

Office automation equipment, Factory automation equipment, Household products, Consumer electronics, etc.

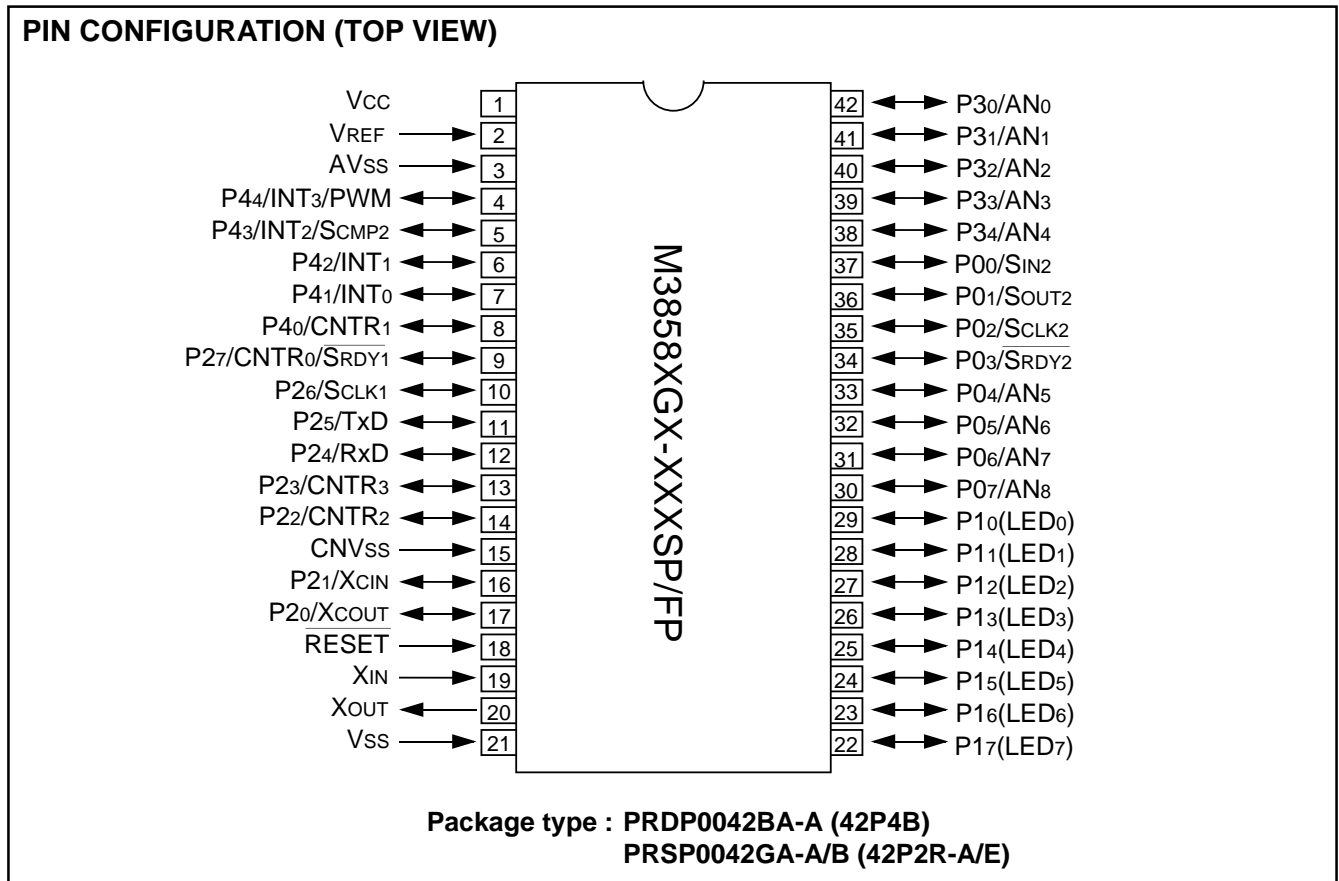

Fig. 1 Pin configuration of M3858XGX-XXXSP/FP

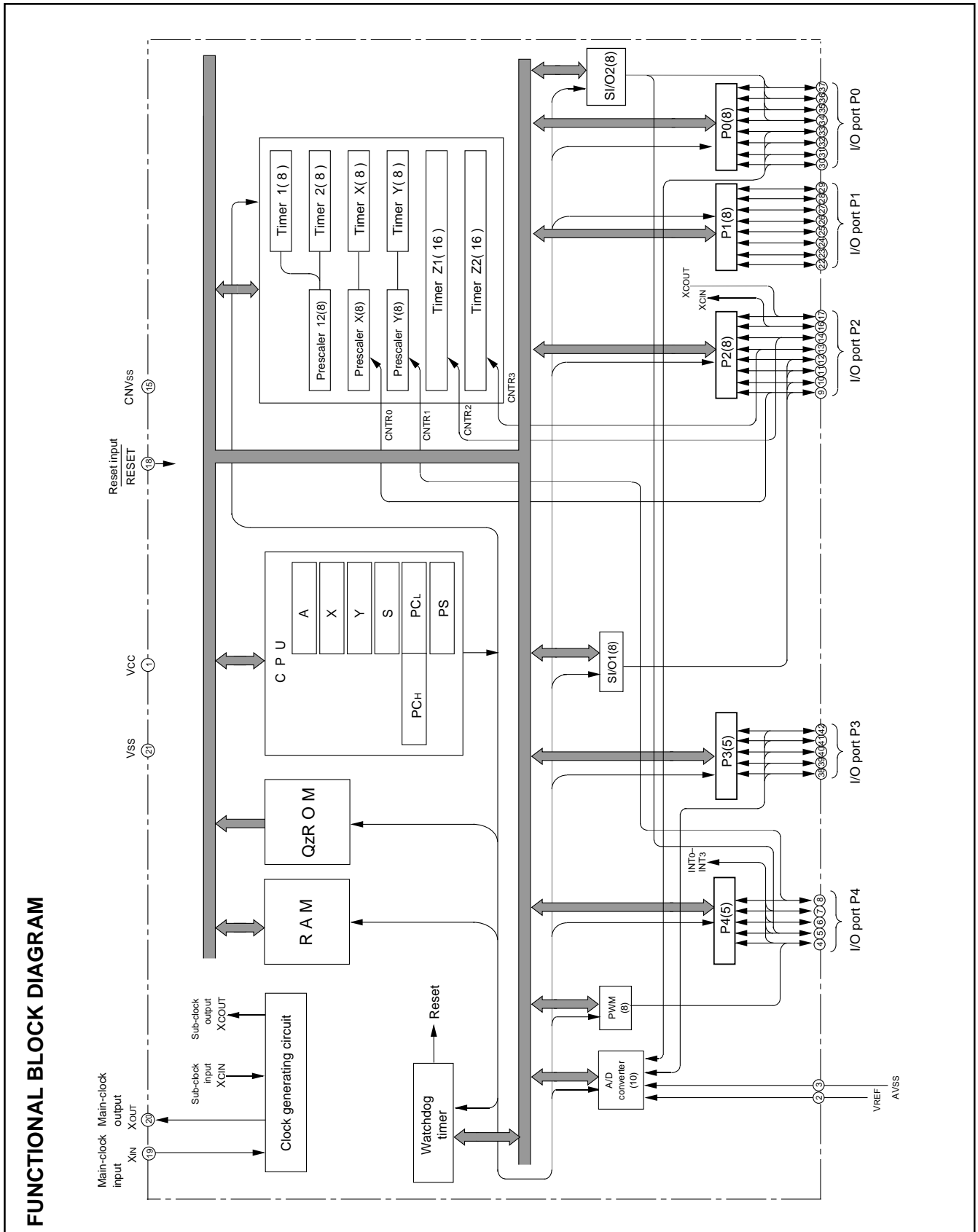

Fig. 2 Functional block diagram

## PIN DESCRIPTION

Table 1 Pin description

Pin	Name	Functions	
			Function except a port function
Vcc, Vss	Power source	•Apply voltage of 2.7 V – 5.5 V to Vcc, and 0 V to Vss.	
CNVss	CNVss input	<ul style="list-style-type: none"> <li>•This pin controls the operation mode of the chip and is shared with the VPP pin which is the power source input pin for programming the built-in QzROM.</li> <li>•Normally connected to Vss.</li> </ul>	
VREF	Reference voltage	•Reference voltage input pin for A/D converter.	
AVss	Analog power source	<ul style="list-style-type: none"> <li>•Analog power source input pin for A/D converter.</li> <li>•Connect to Vss.</li> </ul>	
RESET	Reset input	•Reset input pin for active "L".	
XIN	Clock input	<ul style="list-style-type: none"> <li>•Input and output pins for the clock generating circuit.</li> <li>•Connect a ceramic resonator or quartz-crystal oscillator between the XIN and XOUT pins to set the oscillation frequency.</li> </ul>	
XOUT	Clock output	<ul style="list-style-type: none"> <li>•When an external clock is used, connect the clock source to the XIN pin and leave the XOUT pin open.</li> </ul>	
P00/SIN2 P01/SOUT2 P02/SCLK2 P03/SRDY2 P04/AN5–P07/AN8	I/O port P0	<ul style="list-style-type: none"> <li>•8-bit I/O port.</li> <li>•I/O direction register allows each pin to be individually programmed as either input or output.</li> <li>•CMOS compatible input level.</li> <li>•CMOS 3-state output structure.</li> <li>•Pull-up control is enabled in a bit unit.</li> </ul>	<ul style="list-style-type: none"> <li>• Serial I/O2 function pin</li> <li>• A/D converter input pin</li> </ul>
P10–P17	I/O port P1	<ul style="list-style-type: none"> <li>•P10 to P17 (8 bits) are enabled to output large current for LED drive.</li> </ul>	
P20/XCOUT P21/XCIN P22/CNTR2 P23/CNTR3 P24/RxD P25/TxD P26/SCLK1 P27/CNTR0/ SRDY1	I/O port P2	<ul style="list-style-type: none"> <li>•8-bit I/O port.</li> <li>•I/O direction register allows each pin to be individually programmed as either input or output.</li> <li>•CMOS compatible input level.</li> <li>•CMOS3-state output structure.</li> <li>•Pull-up control is enabled in a bit unit.</li> </ul>	<ul style="list-style-type: none"> <li>• Sub-clock generating circuit I/O pins (connect a resonator)</li> <li>• Timer Z1 function pin</li> <li>• Timer Z2 function pin</li> <li>• Serial I/O1 function pin</li> <li>• Timer X function pin/ Serial I/O1 function pin</li> </ul>
P30/AN0– P34/AN4	I/O port P3	<ul style="list-style-type: none"> <li>•5-bit I/O port with the same function as port P0.</li> <li>•CMOS compatible input level.</li> <li>•CMOS 3-state output structure.</li> <li>•Pull-up control is enabled in a bit unit.</li> </ul>	•A/D converter input pin
P40/CNTR1 P41/INT0 P42/INT1 P43/INT2/SCMP2 P44/INT3/PWM	I/O port P4	<ul style="list-style-type: none"> <li>•5-bit I/O port with the same function as port P0.</li> <li>•CMOS compatible input level.</li> <li>•CMOS 3-state output structure.</li> <li>•Pull-up control is enabled in a bit unit.</li> </ul>	<ul style="list-style-type: none"> <li>• Timer Y function pin</li> <li>• Interrupt input pins</li> <li>• Interrupt input pin</li> <li>• SCMP2 output pin</li> <li>• Interrupt input pin</li> <li>• PWM output pin</li> </ul>

### PART NUMBERING

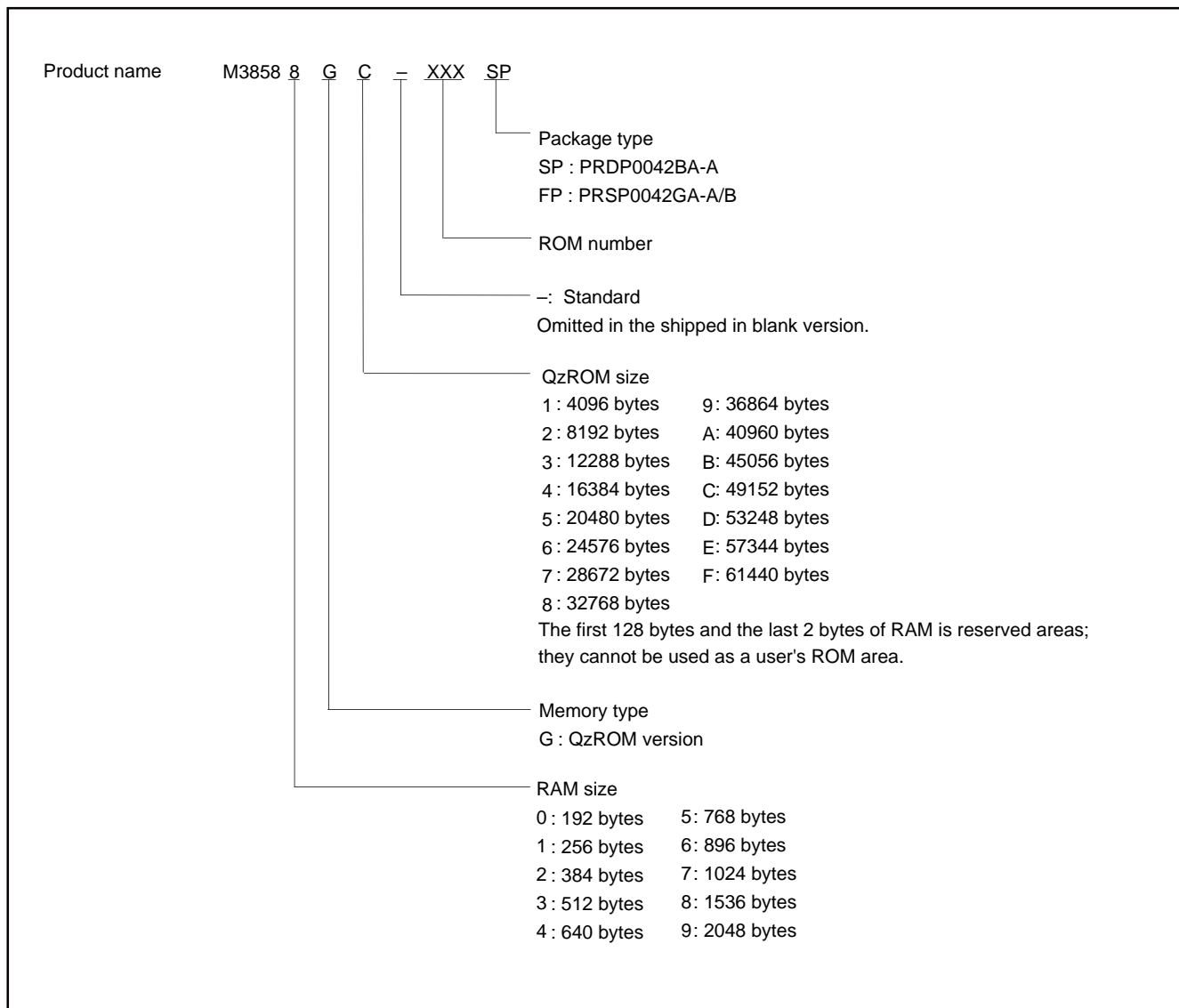

Fig. 3 Part numbering

**GROUP EXPANSION**

Renesas Technology plans to expand the 3858 group as follows.

**Memory Type**

Support for QzROM version.

**Memory Size**

QzROM size ..... 48 K bytes  
 RAM size ..... 1.5 K bytes

**Packages**

PRDP0042BA-A ..... 42-pin shrink plastic-molded SDIP  
 PRSP0042GA-A/B ..... 42-pin plastic-molded SSOP

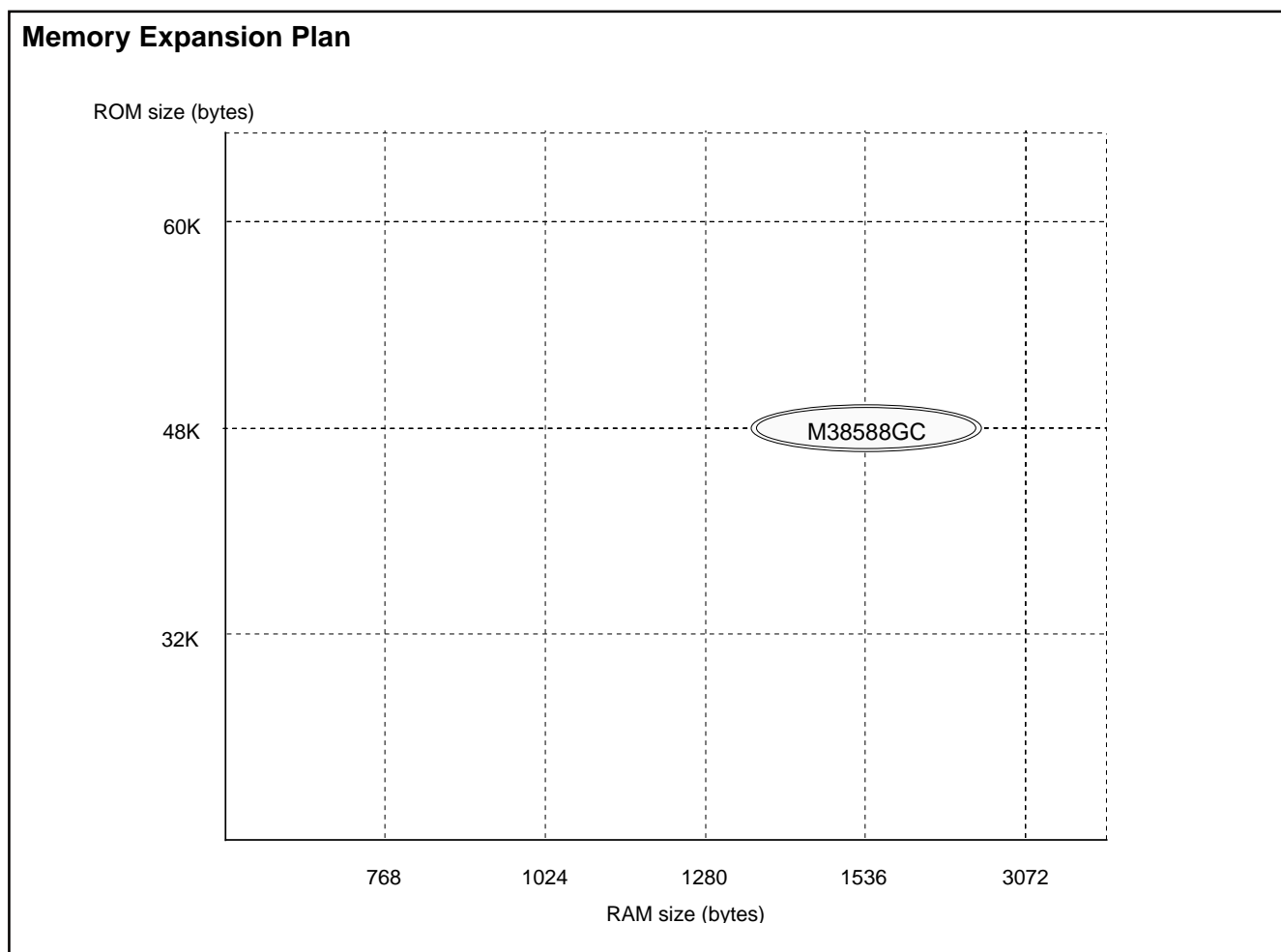

Fig. 4 Memory expansion plan

Table 2 List of products

Part number	ROM size (bytes) ROM size for User in ( )	RAM size (bytes)	Package	Remarks
M38588GC-XXXSP	49152 (49021)	1536	PRDP0042BA-A	
M38588GC-XXXFP			PRSP0042GA-A/B	
M38588GCSP	49152 (49021)	1536	PRDP0042BA-A	Blank
M38588GCFP			PRSP0042GA-A/B	

**FUNCTIONAL DESCRIPTION  
CENTRAL PROCESSING UNIT (CPU)**

The 3858 group uses the standard 740 Family instruction set. Refer to the table of 740 Family addressing modes and machine instructions or the 740 Family Software Manual for details on the instruction set.

Machine-resident 740 Family instructions are as follows:

- The FST and SLW instructions cannot be used.
- The STP, WIT, MUL, and DIV instructions can be used.

**[Accumulator (A)]**

The accumulator is an 8-bit register. Data operations such as data transfer, etc., are executed mainly through the accumulator.

**[Index Register X (X)]**

The index register X is an 8-bit register. In the index addressing modes, the value of the OPERAND is added to the contents of register X and specifies the real address.

**[Index Register Y (Y)]**

The index register Y is an 8-bit register. In partial instruction, the value of the OPERAND is added to the contents of register Y and specifies the real address.

**[Stack Pointer (S)]**

The stack pointer is an 8-bit register used during subroutine calls and interrupts. This register indicates start address of stored area (stack) for storing registers during subroutine calls and interrupts. The low-order 8 bits of the stack address are determined by the contents of the stack pointer. The high-order 8 bits of the stack address are determined by the stack page selection bit. If the stack page selection bit is "0", the high-order 8 bits becomes "0016". If the stack page selection bit is "1", the high-order 8 bits becomes "0116".

The operations of pushing register contents onto the stack and popping them from the stack are shown in Figure 6.

Store registers other than those described in Figure 6 with program when the user needs them during interrupts or subroutine calls (see Table 3).

**[Program Counter (PC)]**

The program counter is a 16-bit counter consisting of two 8-bit registers PCH and PCL. It is used to indicate the address of the next instruction to be executed.

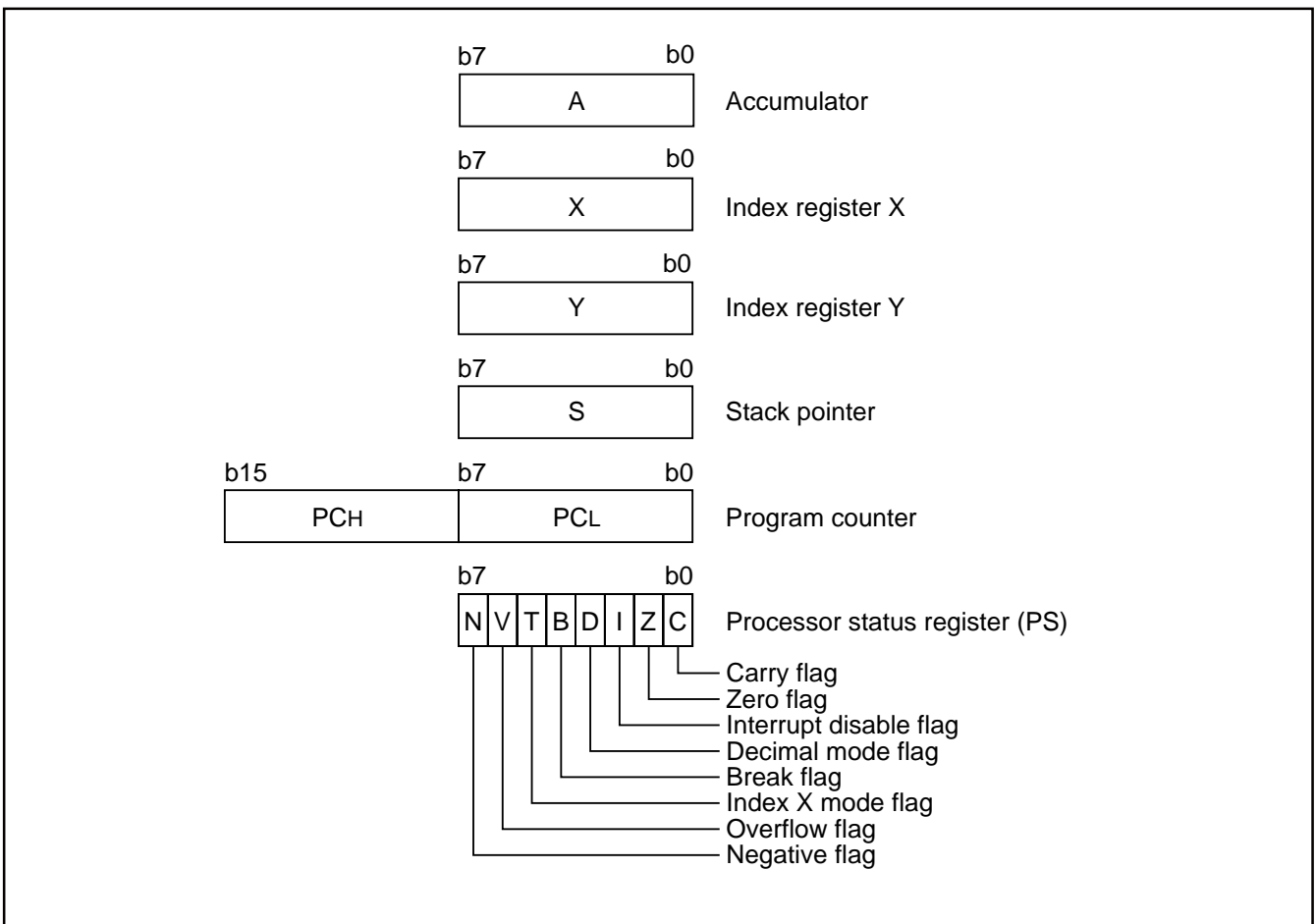

Fig. 5 740 Family CPU register structure

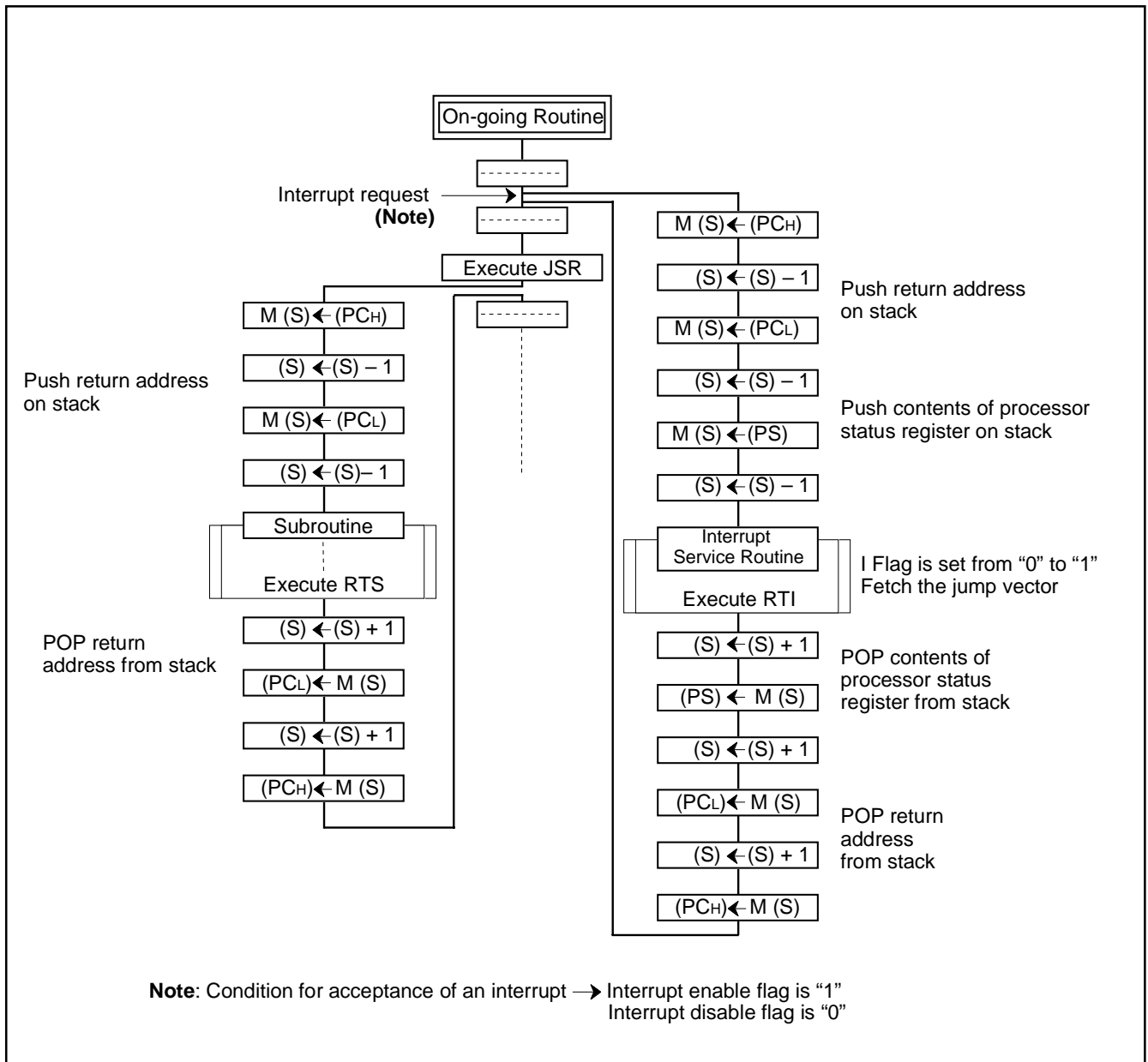

Fig. 6 Register push and pop at interrupt generation and subroutine call

Table 3 Push and pop instructions of accumulator or processor status register

	Push instruction to stack	Pop instruction from stack
Accumulator	PHA	PLA
Processor status register	PHP	PLP

## [Processor status register (PS)]

The processor status register is an 8-bit register consisting of 5 flags which indicate the status of the processor after an arithmetic operation and 3 flags which decide MCU operation. Branch operations can be performed by testing the Carry (C) flag, Zero (Z) flag, Overflow (V) flag, or the Negative (N) flag. In decimal mode, the Z, V, N flags are not valid.

•Bit 0: Carry flag (C)

The C flag contains a carry or borrow generated by the arithmetic logic unit (ALU) immediately after an arithmetic operation. It can also be changed by a shift or rotate instruction.

•Bit 1: Zero flag (Z)

The Z flag is set if the result of an immediate arithmetic operation or a data transfer is "0", and cleared if the result is anything other than "0".

•Bit 2: Interrupt disable flag (I)

The I flag disables all interrupts except for the interrupt generated by the BRK instruction.

Interrupts are disabled when the I flag is "1".

•Bit 3: Decimal mode flag (D)

The D flag determines whether additions and subtractions are executed in binary or decimal. Binary arithmetic is executed when this flag is "0"; decimal arithmetic is executed when it is "1".

Decimal correction is automatic in decimal mode. Only the ADC and SBC instructions can be used for decimal arithmetic.

•Bit 4: Break flag (B)

The B flag is used to indicate that the current interrupt was generated by the BRK instruction. The BRK flag in the processor status register is always "0". When the BRK instruction is used to generate an interrupt, the processor status register is pushed onto the stack with the break flag set to "1".

•Bit 5: Index X mode flag (T)

When the T flag is "0", arithmetic operations are performed between accumulator and memory. When the T flag is "1", direct arithmetic operations and direct data transfers are enabled between memory locations.

•Bit 6: Overflow flag (V)

The V flag is used during the addition or subtraction of one byte of signed data. It is set if the result exceeds +127 to -128. When the BIT instruction is executed, bit 6 of the memory location operated on by the BIT instruction is stored in the overflow flag.

•Bit 7: Negative flag (N)

The N flag is set if the result of an arithmetic operation or data transfer is negative. When the BIT instruction is executed, bit 7 of the memory location operated on by the BIT instruction is stored in the negative flag.

**Table 4 Set and clear instructions of each bit of processor status register**

	C flag	Z flag	I flag	D flag	B flag	T flag	V flag	N flag
Set instruction	SEC	–	SEI	SED	–	SET	–	–
Clear instruction	CLC	–	CLI	CLD	–	CLT	CLV	–



**[CPU Mode Register (CPUM)] 003B16**

The CPU mode register contains the stack page selection bit, etc.

The CPU mode register is allocated at address 003B16.

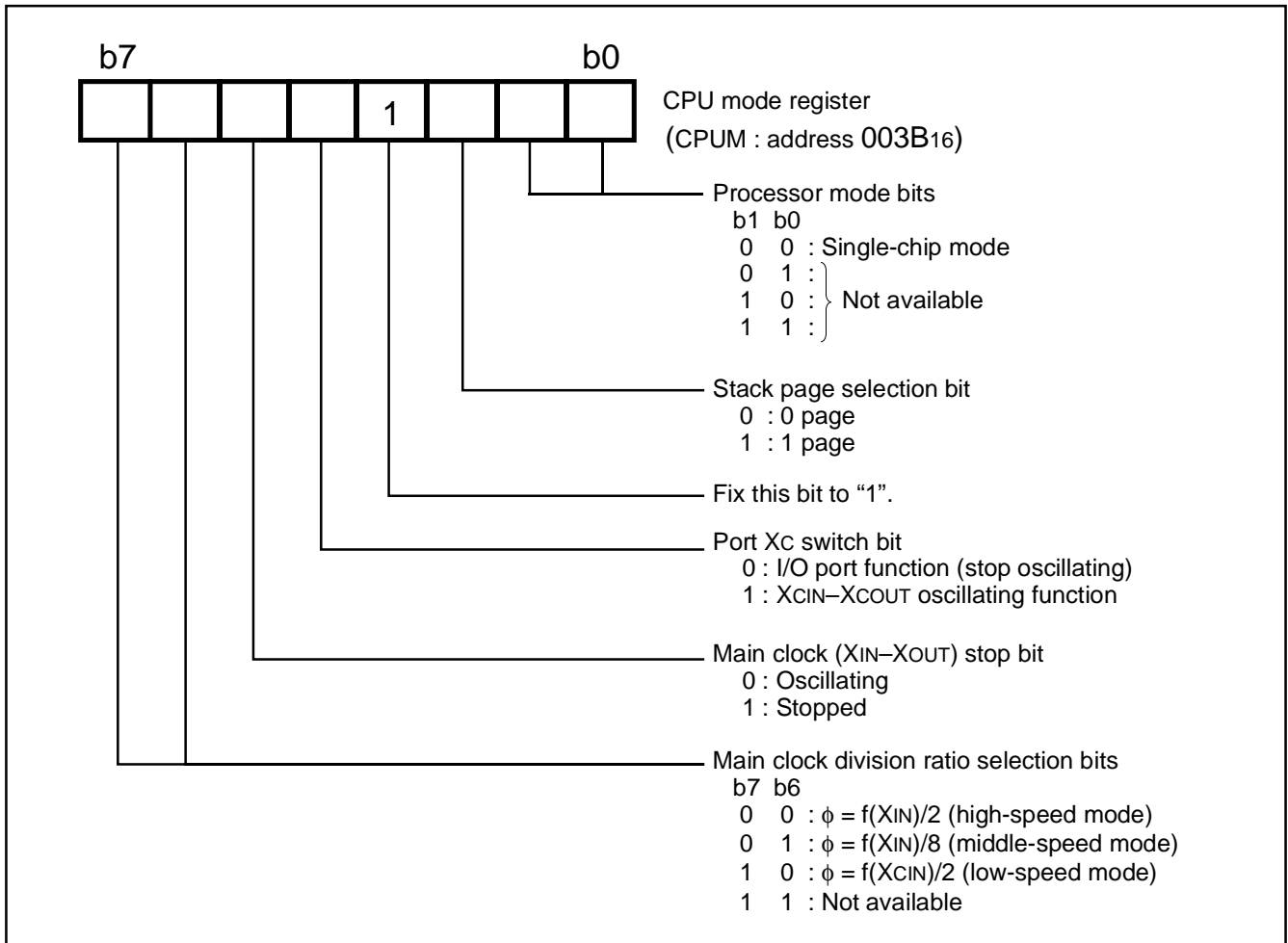

Fig. 7 Structure of CPU mode register

## MEMORY

### Special Function Register (SFR) Area

The Special Function Register area in the zero page contains control registers such as I/O ports and timers.

### RAM

RAM is used for data storage and for stack area of subroutine calls and interrupts.

### ROM

The first 128 bytes and the last 2 bytes of ROM are reserved for device testing and the rest is user area for storing programs.

### Interrupt Vector Area

The interrupt vector area contains reset and interrupt vectors.

### Zero Page

Access to this area with only 2 bytes is possible in the zero page addressing mode.

### Special Page

Access to this area with only 2 bytes is possible in the special page addressing mode.

### ROM Code Protect Address (address FFDB<sub>16</sub>)

Address FFDB<sub>16</sub>, which is the reserved ROM area of QzROM, is the ROM code protect address. "00<sub>16</sub>" is written into this address when selecting the protect bit write by using a serial programmer or selecting protect enabled for writing shipment by Renesas Technology corp.. When "00<sub>16</sub>" is set to the ROM code protect address, the protect function is enabled, so that reading or writing from/to QzROM is disabled by a serial programmer.

As for the QzROM product in blank, the ROM code is protected by selecting the protect bit write at ROM writing with a serial programmer.

As for the QzROM product shipped after writing, "00<sub>16</sub>" (protect enabled) or "FF<sub>16</sub>" (protect disabled) is written into the ROM code protect address when Renesas Technology corp. performs writing. The writing of "00<sub>16</sub>" or "FF<sub>16</sub>" can be selected as ROM option setup ("MASK option" written in the mask file converter) when ordering.

### ■ Notes

Because the contents of RAM are indefinite at reset, set initial values before using.

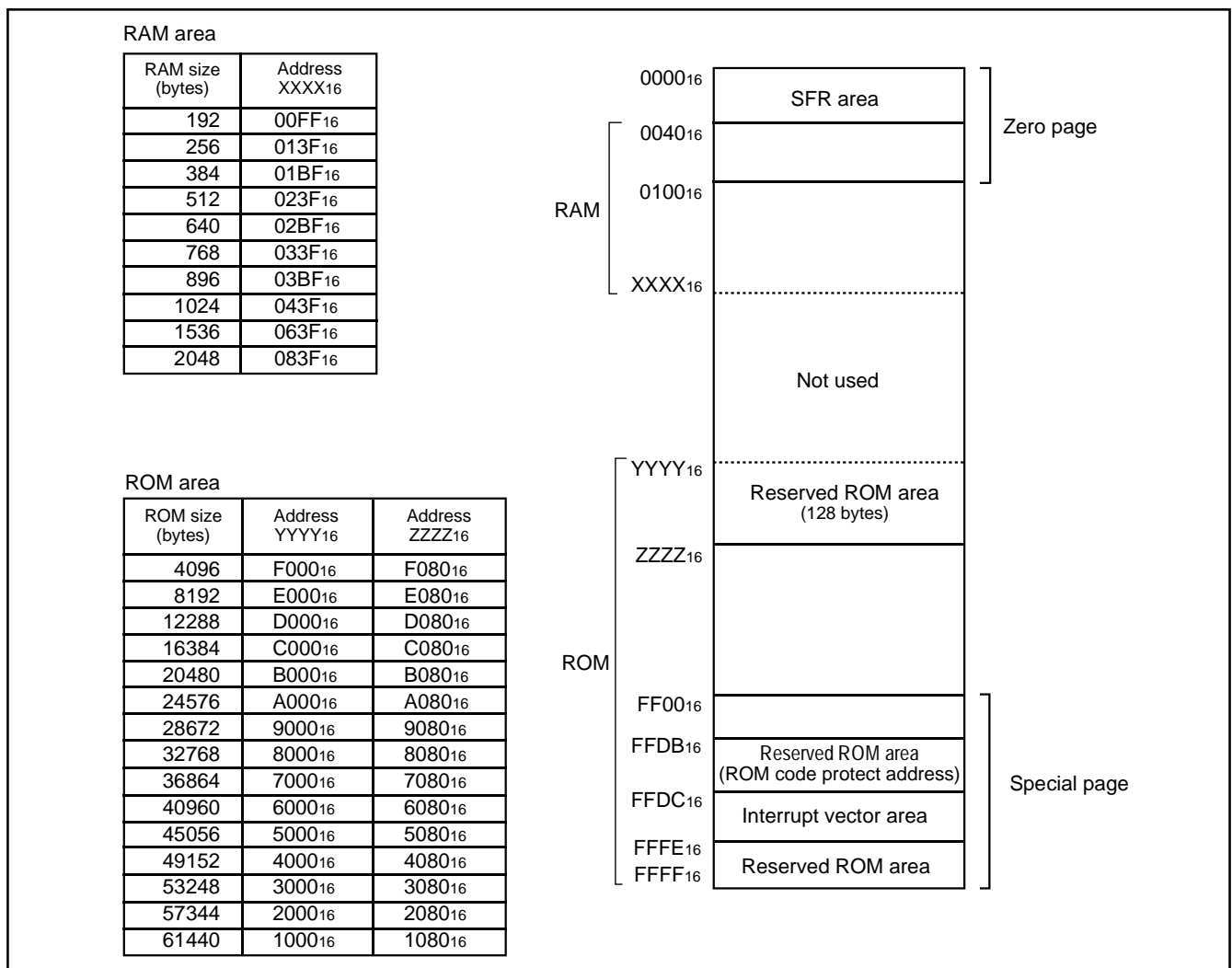

Fig. 8 Memory map diagram

0000 <sub>16</sub>	Port P0 (P0)	0020 <sub>16</sub>	Prescaler 12 (PRE12)
0001 <sub>16</sub>	Port P0 direction register (P0D)	0021 <sub>16</sub>	Timer 1 (T1)
0002 <sub>16</sub>	Port P1 (P1)	0022 <sub>16</sub>	Timer 2 (T2)
0003 <sub>16</sub>	Port P1 direction register (P1D)	0023 <sub>16</sub>	Timer XY mode register (TM)
0004 <sub>16</sub>	Port P2 (P2)	0024 <sub>16</sub>	Prescaler X (PREX)
0005 <sub>16</sub>	Port P2 direction register (P2D)	0025 <sub>16</sub>	Timer X (TX)
0006 <sub>16</sub>	Port P3 (P3)	0026 <sub>16</sub>	Prescaler Y (PREY)
0007 <sub>16</sub>	Port P3 direction register (P3D)	0027 <sub>16</sub>	Timer Y (TY)
0008 <sub>16</sub>	Port P4 (P4)	0028 <sub>16</sub>	Timer Z1 mode register (TZ1M)
0009 <sub>16</sub>	Port P4 direction register (P4D)	0029 <sub>16</sub>	Timer Z1 low-order (TZ1L)
000A <sub>16</sub>		002A <sub>16</sub>	Timer Z1 high-order (TZ1H)
000B <sub>16</sub>		002B <sub>16</sub>	Timer Z2 mode register (TZ2M)
000C <sub>16</sub>		002C <sub>16</sub>	Timer Z2 low-order (TZ2L)
000D <sub>16</sub>		002D <sub>16</sub>	Timer Z2 high-order (TZ2H)
000E <sub>16</sub>		002E <sub>16</sub>	Timer 12, X count source selection register (T12XCSS)
000F <sub>16</sub>		002F <sub>16</sub>	Timer Y, Z1 count source selection register (TYZ1CSS)
0010 <sub>16</sub>	Port P0 pull-up control register (PULL0)	0030 <sub>16</sub>	Timer Z2 count source selection register (TZ2CSS)
0011 <sub>16</sub>	Port P1 pull-up control register (PULL1)	0031 <sub>16</sub>	
0012 <sub>16</sub>	Port P2 pull-up control register (PULL2)	0032 <sub>16</sub>	
0013 <sub>16</sub>	Port P3 pull-up control register (PULL3)	0033 <sub>16</sub>	
0014 <sub>16</sub>	Port P4 pull-up control register (PULL4)	0034 <sub>16</sub>	AD control register (ADCON)
0015 <sub>16</sub>	Serial I/O2 control register 1 (SIO2CON1)	0035 <sub>16</sub>	AD conversion register (AD)
0016 <sub>16</sub>	Serial I/O2 control register 2 (SIO2CON2)	0036 <sub>16</sub>	Interrupt source selection register (INTSEL)
0017 <sub>16</sub>	Serial I/O2 register (SIO2)	0037 <sub>16</sub>	Reserved *
0018 <sub>16</sub>	Transmit/Receive buffer register (TB/RB)	0038 <sub>16</sub>	MISRG
0019 <sub>16</sub>	Serial I/O1 status register (SIO1STS)	0039 <sub>16</sub>	Watchdog timer control register (WDTCON)
001A <sub>16</sub>	Serial I/O1 control register (SIO1CON)	003A <sub>16</sub>	Interrupt edge selection register (INTEDGE)
001B <sub>16</sub>	UART control register (UARTCON)	003B <sub>16</sub>	CPU mode register (CPUM)
001C <sub>16</sub>	Baud rate generator (BRG)	003C <sub>16</sub>	Interrupt request register 1 (IREQ1)
001D <sub>16</sub>	PWM control register (PWMCON)	003D <sub>16</sub>	Interrupt request register 2 (IREQ2)
001E <sub>16</sub>	PWM prescaler (PREPWM)	003E <sub>16</sub>	Interrupt control register 1 (ICON1)
001F <sub>16</sub>	PWM register (PWM)	003F <sub>16</sub>	Interrupt control register 2 (ICON2)

\* Reserved : Do not write any data to this addresses, because these areas are reserved.

Fig. 9 Memory map of special function register (SFR)

## I/O PORTS

The I/O ports have direction registers which determine the input/output direction of each individual pin. Each bit in a direction register corresponds to one pin, and each pin can be set to be input port or output port.

When "0" is written to the bit corresponding to a pin, that pin becomes an input pin. When "1" is written to that bit, that pin becomes an output pin.

If data is read from a pin which is set to output, the value of the port output latch is read, not the value of the pin itself. Pins set to input are floating. If a pin set to input is written to, only the port output latch is written to and the pin remains floating.

By setting the port P0 pull-up control register (address 0010<sub>16</sub>), the port P1 pull-up control register (address 0011<sub>16</sub>), the port P2 pull-up control register (address 0012<sub>16</sub>), the port P3 pull-up control register (address 0013<sub>16</sub>), or the port P4 pull-up control register (address 0014<sub>16</sub>), ports can control pull-up with a program. However, the contents of these registers do not affect ports programmed as the output ports.

**Table 5 I/O port function**

Pin	Name	Input/Output	I/O Structure	Non-Port Function	Related SFRs	Ref.No.
P00/SIN2 P01/SOUT2 P02/SCLK2 P03/SRDY2	Port P0	Input/output, individual bits	CMOS compatible input level CMOS 3-state output	Serial I/O2 function I/O	Serial I/O2 control register	(1) (2) (3) (4)
P04/AN5–P07/AN8				A/D converter input	AD control register AD input selection register	(13)
P10–P17	Port P1					(5)
P20/XCOUT P21/XCIN	Port P2			Sub-clock generating circuit	CPU mode register	(6) (7)
P22/CNTR2				Timer Z1 function I/O	Timer Z1 mode register	(8)
P23/CNTR3				Timer Z2 function I/O	Timer Z2 mode register	(8)
P24/RxD P25/TxD P26/SCLK1				Serial I/O1 function I/O	Serial I/O1 control register	(9) (10) (11)
P27/CNTR0/SRDY1				Timer X function I/O Serial I/O1 function I/O	Timer XY mode register Serial I/O1 control register	(12)
P30/AN0– P34/AN4				Port P3 <b>(Note)</b>		
P40/CNTR1	Port P4 <b>(Note)</b>			Timer Y function I/O	Timer XY mode register	(14)
P41/INT0 P42/INT1				External interrupt input	Interrupt edge selection register	(15)
P43/INT2/SCMP2				External interrupt input SCMP2 output	Interrupt edge selection register Serial I/O2 control register	(16)
P44/INT3/PWM				External interrupt input PWM output	Interrupt edge selection register PWM control register	(17)

**Note:** When bits 5 to 7 of Ports P3 and P4 are read out, the contents are undefined.

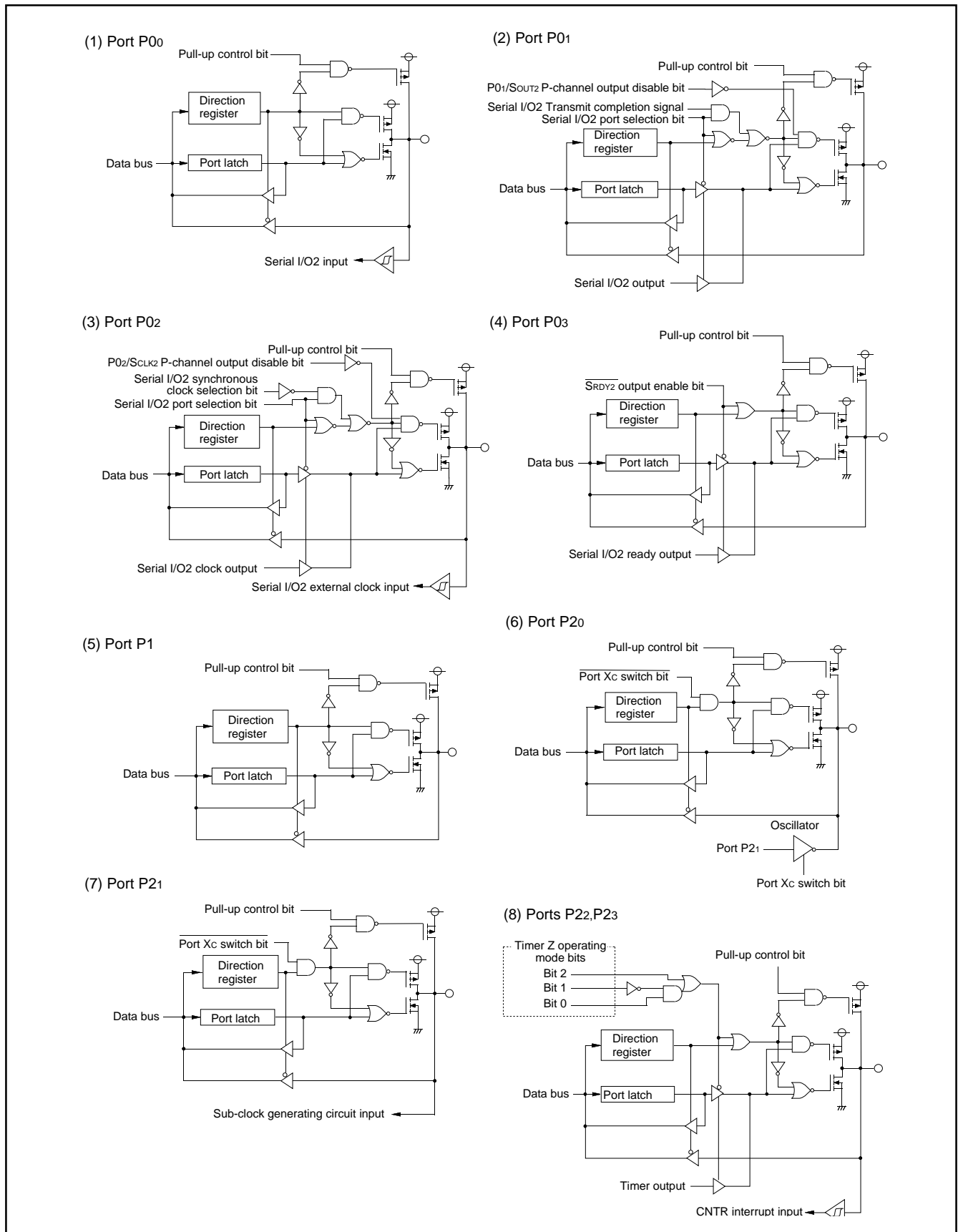

Fig. 10 Port block diagram (1)

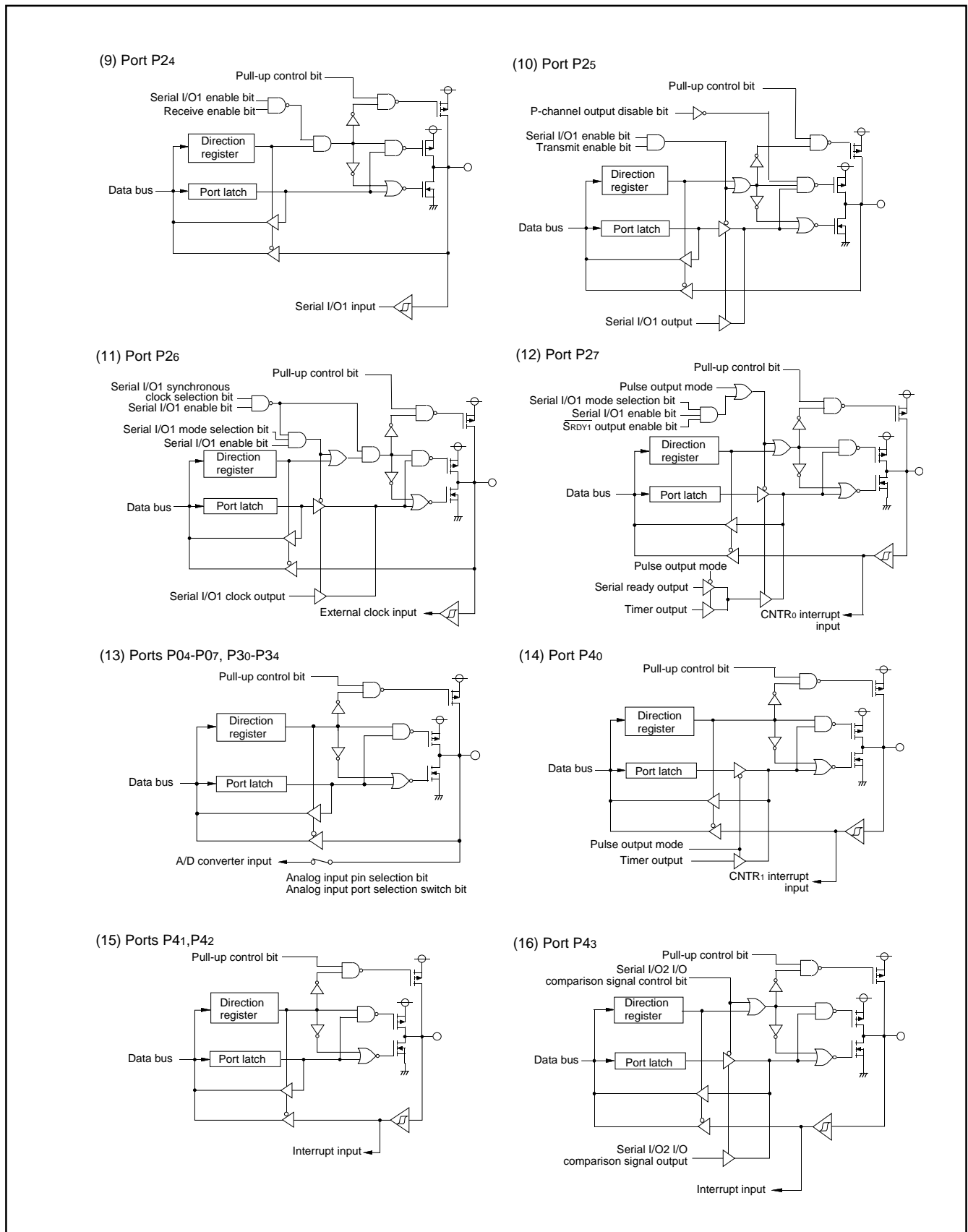

Fig. 11 Port block diagram (2)

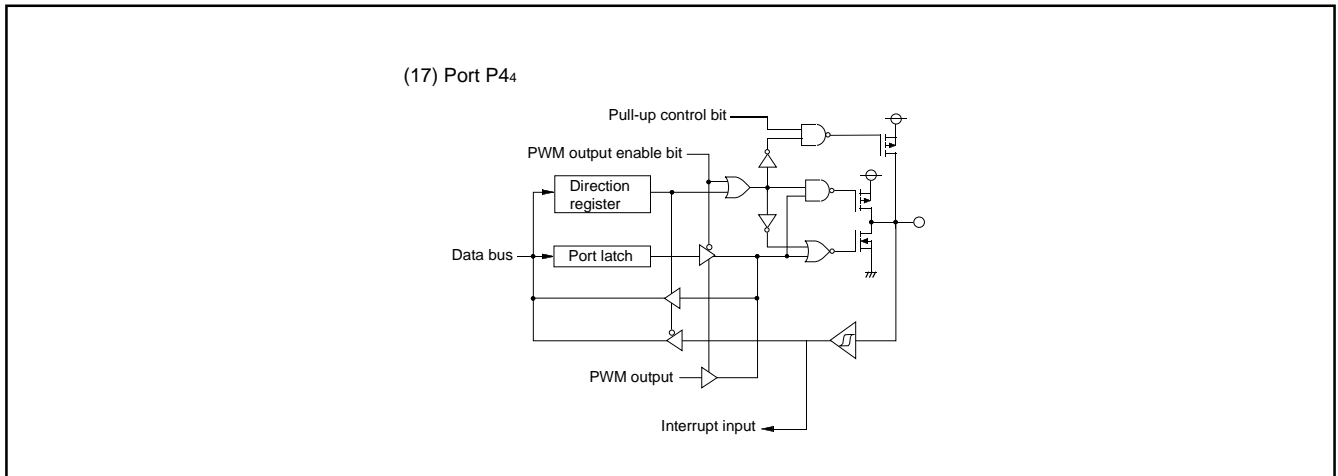

Fig. 12 Port block diagram (3)

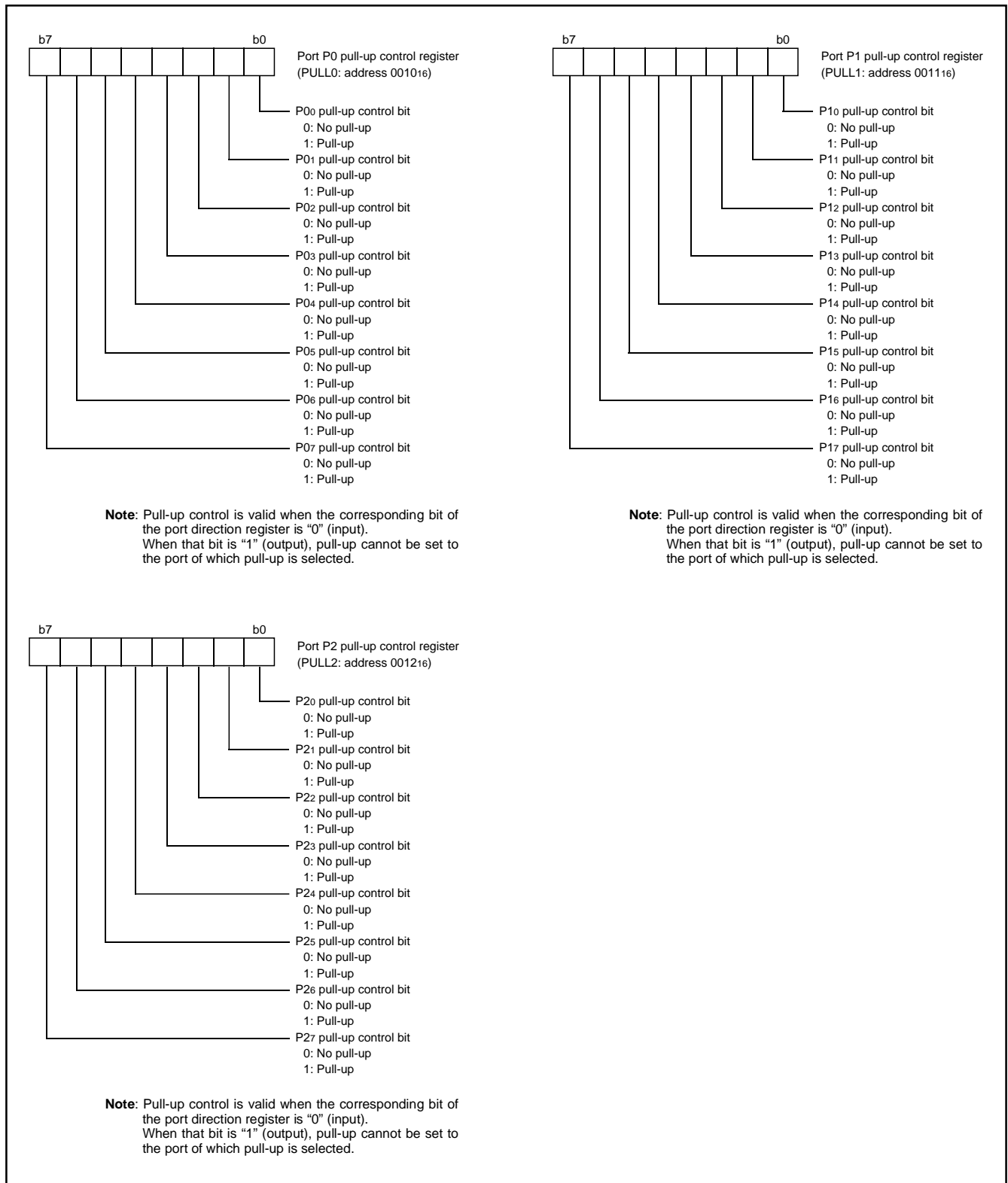

Fig. 13 Structure of port registers (1)



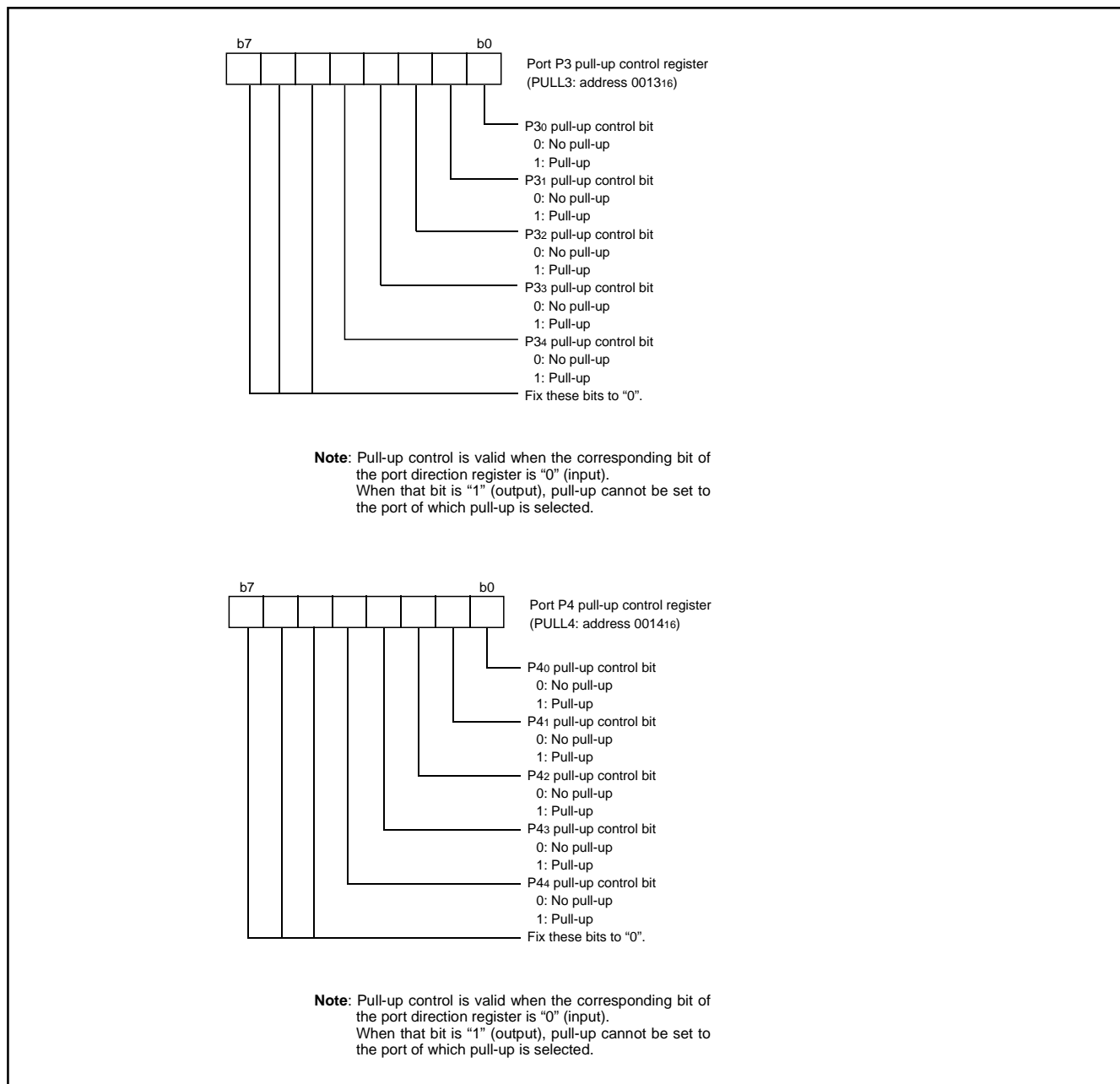

Fig. 14 Structure of port registers (2)

## INTERRUPTS

The 3858 group's interrupts are a type of vector and occur by 16 sources among 19 sources: eight external, ten internal, and one software.

### Interrupt Control

Each interrupt is controlled by an interrupt request bit, an interrupt enable bit, and the interrupt disable flag except for the software interrupt set by the BRK instruction. An interrupt occurs if the corresponding interrupt request and enable bits are "1" and the interrupt disable flag is "0".

Interrupt enable bits can be set or cleared by software.

Interrupt request bits can be cleared by software, but cannot be set by software.

The reset and the BRK instruction cannot be disabled with any flag or bit. The I (interrupt disable) flag disables all interrupts except the reset and the BRK instruction interrupt.

When several interrupt requests occur at the same time, the interrupts are received according to priority.

### Interrupt Operation

By acceptance of an interrupt, the following operations are automatically performed:

1. The contents of the program counter and the processor status register are automatically pushed onto the stack.
2. The interrupt disable flag is set and the corresponding interrupt request bit is cleared.
3. The interrupt jump destination address is read from the vector table into the program counter.

### Interrupt Source Selection

Which of each combination of the following interrupt sources can be selected by the interrupt source selection register (address 003916).

1. INT3 or Serial I/O2
2. Timer Z1 or CNTR2
3. Timer Z2 or CNTR3
4. CNTR0 or CNTR2
5. CNTR1 or CNTR3

**Table 6 Interrupt vector addresses and priority**

Interrupt Source	Priority	Vector Addresses (Note 1)		Interrupt Request Generating Conditions	Remarks
		High	Low		
Reset (Note 2)	1	FFFD <sub>16</sub>	FFFC <sub>16</sub>	At reset	Non-maskable
INT <sub>0</sub>	2	FFFB <sub>16</sub>	FFFA <sub>16</sub>	At detection of either rising or falling edge of INT <sub>0</sub> input	External interrupt (active edge selectable)
Timer Z1	3	FFF9 <sub>16</sub>	FFF8 <sub>16</sub>	At timer Z1 underflow	
CNTR <sub>2</sub>				At detection of either rising or falling edge of CNTR <sub>2</sub> input	External interrupt (active edge selectable)
INT <sub>1</sub>	4	FFF7 <sub>16</sub>	FFF6 <sub>16</sub>	At detection of either rising or falling edge of INT <sub>1</sub> input	External interrupt (active edge selectable)
INT <sub>2</sub>	5	FFF5 <sub>16</sub>	FFF4 <sub>16</sub>	At detection of either rising or falling edge of INT <sub>2</sub> input	External interrupt (active edge selectable)
INT <sub>3</sub>	6	FFF3 <sub>16</sub>	FFF2 <sub>16</sub>	At detection of either rising or falling edge of INT <sub>3</sub> input	External interrupt (active edge selectable)
Serial I/O <sub>2</sub>				At completion of serial I/O <sub>2</sub> data transmission or reception	Valid when serial I/O <sub>2</sub> is selected
Timer Z2	7	FFF1 <sub>16</sub>	FFF0 <sub>16</sub>	At timer Z2 underflow	
CNTR <sub>3</sub>				At detection of either rising or falling edge of CNTR <sub>3</sub> input	External interrupt (active edge selectable)
Timer X	8	FFEF <sub>16</sub>	FFEE <sub>16</sub>	At timer X underflow	
Timer Y	9	FFED <sub>16</sub>	FFEC <sub>16</sub>	At timer Y underflow	
Timer 1	10	FFEB <sub>16</sub>	FFEA <sub>16</sub>	At timer 1 underflow	STP release timer underflow
Timer 2	11	FFE9 <sub>16</sub>	FFE8 <sub>16</sub>	At timer 2 underflow	
Serial I/O <sub>1</sub> reception	12	FFE7 <sub>16</sub>	FFE6 <sub>16</sub>	At completion of serial I/O <sub>1</sub> data reception	Valid when serial I/O <sub>1</sub> is selected
Serial I/O <sub>1</sub> transmission	13	FFE5 <sub>16</sub>	FFE4 <sub>16</sub>	At completion of serial I/O <sub>1</sub> transmission shift or when transmission buffer is empty	Valid when serial I/O <sub>1</sub> is selected
CNTR <sub>0</sub>	14	FFE3 <sub>16</sub>	FFE2 <sub>16</sub>	At detection of either rising or falling edge of CNTR <sub>0</sub> input	External interrupt (active edge selectable)
CNTR <sub>2</sub>				At detection of either rising or falling edge of CNTR <sub>2</sub> input	
CNTR <sub>1</sub>	15	FFE1 <sub>16</sub>	FFE0 <sub>16</sub>	At detection of either rising or falling edge of CNTR <sub>1</sub> input	External interrupt (active edge selectable)
CNTR <sub>3</sub>				At detection of either rising or falling edge of CNTR <sub>3</sub> input	
A/D converter	16	FFDF <sub>16</sub>	FFDE <sub>16</sub>	At completion of A/D conversion	
BRK instruction	17	FFDD <sub>16</sub>	FFDC <sub>16</sub>	At BRK instruction execution	Non-maskable software interrupt

**Notes 1:** Vector addresses contain interrupt jump destination addresses.

**2:** Reset function in the same way as an interrupt with the highest priority.

## ■ Notes

When setting the followings, the interrupt request bit may be set to "1".

- When setting external interrupt active edge

Related register: Interrupt edge selection register (address 003A16)  
 Timer XY mode register (address 002316)  
 Timer Z1 mode register (address 002816)  
 Timer Z2 mode register (address 002B16)

- When switching interrupt sources of an interrupt vector address where two or more interrupt sources are allocated

Related register: Interrupt source selection register  
 (address 003616)

When not requiring for the interrupt occurrence synchronized with these setting, take the following sequence.

- ①Set the corresponding interrupt enable bit to "0" (disabled).
- ②Set the interrupt edge select bit or the interrupt source select bit to "1".
- ③Set the corresponding interrupt request bit to "0" after 1 or more instructions have been executed.
- ④Set the corresponding interrupt enable bit to "1" (enabled).

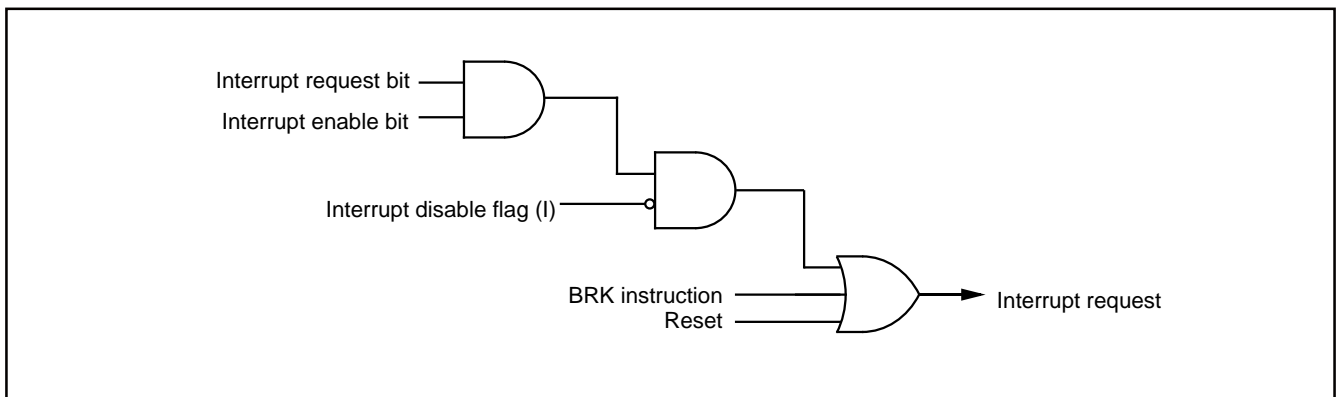

Fig. 15 Interrupt control

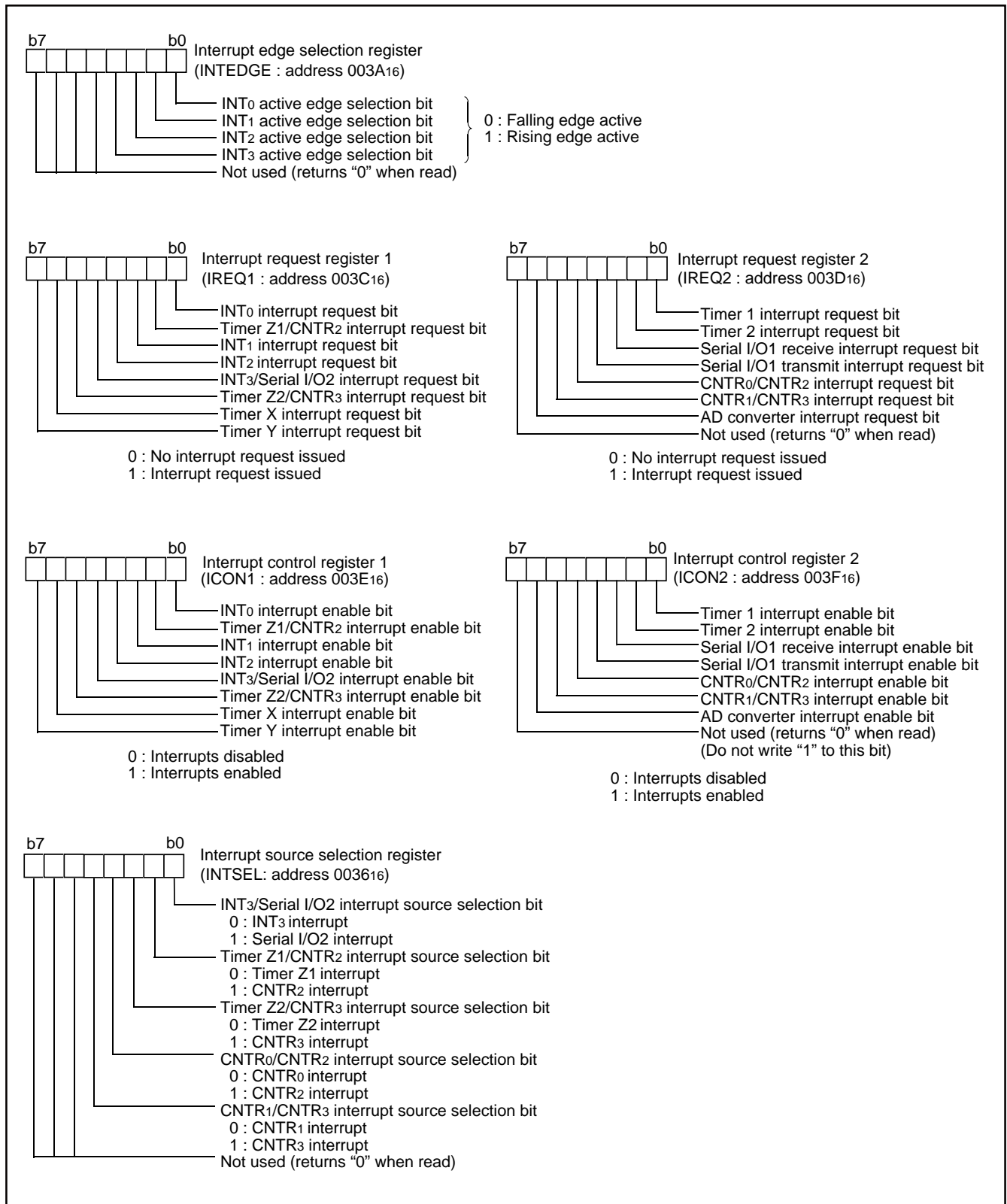

Fig. 16 Structure of interrupt-related registers

## TIMERS

### ●8-bit Timers

The 3858 group has four 8-bit timers: timer 1, timer 2, timer X, and timer Y.

The timer 1 and timer 2 use one prescaler in common, and the timer X and timer Y use each prescaler. Those are 8-bit prescalers. Each of the timers and prescalers has a timer latch or a prescaler latch.

The division ratio of each timer or prescaler is given by  $1/(n + 1)$ , where  $n$  is the value in the corresponding timer or prescaler latch. All timers are down-counters. When the timer reaches "00<sub>16</sub>", an underflow occurs at the next count pulse and the contents of the corresponding timer latch are reloaded into the timer and the count is continued. When the timer underflows, the interrupt request bit corresponding to that timer is set to "1".

#### ●Timer divider

The divider count source is switched by the main clock division ratio selection bits of CPU mode register (bits 7 and 6 at address 003B<sub>16</sub>). When these bits are "00" (high-speed mode) or "01" (middle-speed mode), X<sub>IN</sub> is selected. When these bits are "10" (low-speed mode), X<sub>CIN</sub> is selected.

#### ●Prescaler 12

The prescaler 12 counts the output of the timer divider. The count source is selected by the timer 12, X count source selection register (address 002E<sub>16</sub>) among 1/2, 1/4, 1/8, 1/16, 1/32, 1/64, 1/128, 1/256, 1/512, 1/1024 of  $f(X_{IN})$  or  $f(X_{CIN})$ .

### Timer 1 and Timer 2

The timer 1 and timer 2 counts the output of prescaler 12 and periodically set the interrupt request bit.

#### ●Prescaler X and prescaler Y

The prescaler X and prescaler Y count the output of the timer divider or  $f(X_{CIN})$ . The count source is selected by the timer 12, X count source selection register (address 002E<sub>16</sub>) and the timer Y, Z1 count source selection register (address 002F<sub>16</sub>) among 1/2, 1/4, 1/8, 1/16, 1/32, 1/64, 1/128, 1/256, 1/512, and 1/1024 of  $f(X_{IN})$  or  $f(X_{CIN})$ ; and  $f(X_{CIN})$ .

### Timer X and Timer Y

The timer X and timer Y can each select one of four operating modes by setting the timer XY mode register (address 0023<sub>16</sub>).

#### (1) Timer mode

##### ●Mode selection

This mode can be selected by setting "00" to the timer X operating mode bits (bits 1 and 0) and the timer Y operating mode bits (bits 5 and 4) of the timer XY mode register (address 0023<sub>16</sub>).

##### ●Explanation of operation

The timer count operation is started by setting "0" to the timer X count stop bit (bit 3) and the timer Y count stop bit (bit 7) of the timer XY mode register (address 0023<sub>16</sub>).

When the timer reaches "00<sub>16</sub>", an underflow occurs at the next count pulse and the contents of timer latch are reloaded into the timer and the count is continued.

#### (2) Pulse output mode

##### ●Mode selection

This mode can be selected by setting "01" to the timer X operating mode bits (bits 1 and 0) and the timer Y operating mode bits (bits 5 and 4) of the timer XY mode register (address 0023<sub>16</sub>).

##### ●Explanation of operation

The operation is the same as the timer mode's. Moreover the pulse which is inverted each time the timer underflows is output from CNTR0/CNTR1 pin. Regardless of the timer counting or not the output of CNTR0/CNTR1 pin is initialized to the level of specified by their active edge switch bits when writing to the timer. When the CNTR0 active edge switch bit (bit 2) and the CNTR1 active edge switch bit (bit 6) of the timer XY mode register (address 0023<sub>16</sub>) is "0", the output starts with "H" level. When it is "1", the output starts with "L" level.

Switching the CNTR0 or CNTR1 active edge switch bit will reverse the output level of the corresponding CNTR0 or CNTR1 pin.

##### ■Precautions

Set the double-function port of CNTR0/CNTR1 pin and port P27/P40 to output in this mode.

### (3) Event counter mode

#### ●Mode selection

This mode can be selected by setting "10" to the timer X operating mode bits (bits 1 and 0) and the timer Y operating mode bits (bits 5 and 4) of the timer XY mode register (address 002316).

#### ●Explanation of operation

The operation is the same as the timer mode's except that the timer counts signals input from the CNTR0 or CNTR1 pin. The valid edge for the count operation depends on the CNTR0 active edge switch bit (bit 2) or the CNTR1 active edge switch bit (bit 6) of the timer XY mode register (address 002316). When it is "0", the rising edge is valid. When it is "1", the falling edge is valid.

#### ■Precautions

Set the double-function port of CNTR0/CNTR1 pin and port P27/P40 to input in this mode.

### (4) Pulse width measurement mode

#### ●Mode selection

This mode can be selected by setting "11" to the timer X operating mode bits (bits 1 and 0) and the timer Y operating mode bits (bits 5 and 4) of the timer XY mode register (address 002316).

#### ●Explanation of operation

When the CNTR0 active edge switch bit (bit 2) or the CNTR1 active edge switch bit (bit 6) of the timer XY mode register (address 002316) is "1", the timer counts during the term of one falling edge of CNTR0/CNTR1 pin input until the next rising edge of input ("L" term). When it is "0", the timer counts during the term of one rising edge input until the next falling edge input ("H" term).

#### ■Precautions

Set the double-function port of CNTR0/CNTR1 pin and port P27/P40 to input in this mode.

The count operation can be stopped by setting "1" to the timer X count stop bit (bit 3) and the timer Y count stop bit (bit 7) of the timer XY mode register (address 002316). The interrupt request bit is set to "1" each time the timer underflows.

#### ●Precautions when switching count source

When switching the count source by the timer 12, X and Y count source selection bits, the value of timer count is altered in considerable amount owing to generating of thin pulses on the count input signals.

Therefore, select the timer count source before setting the value to the prescaler and the timer.

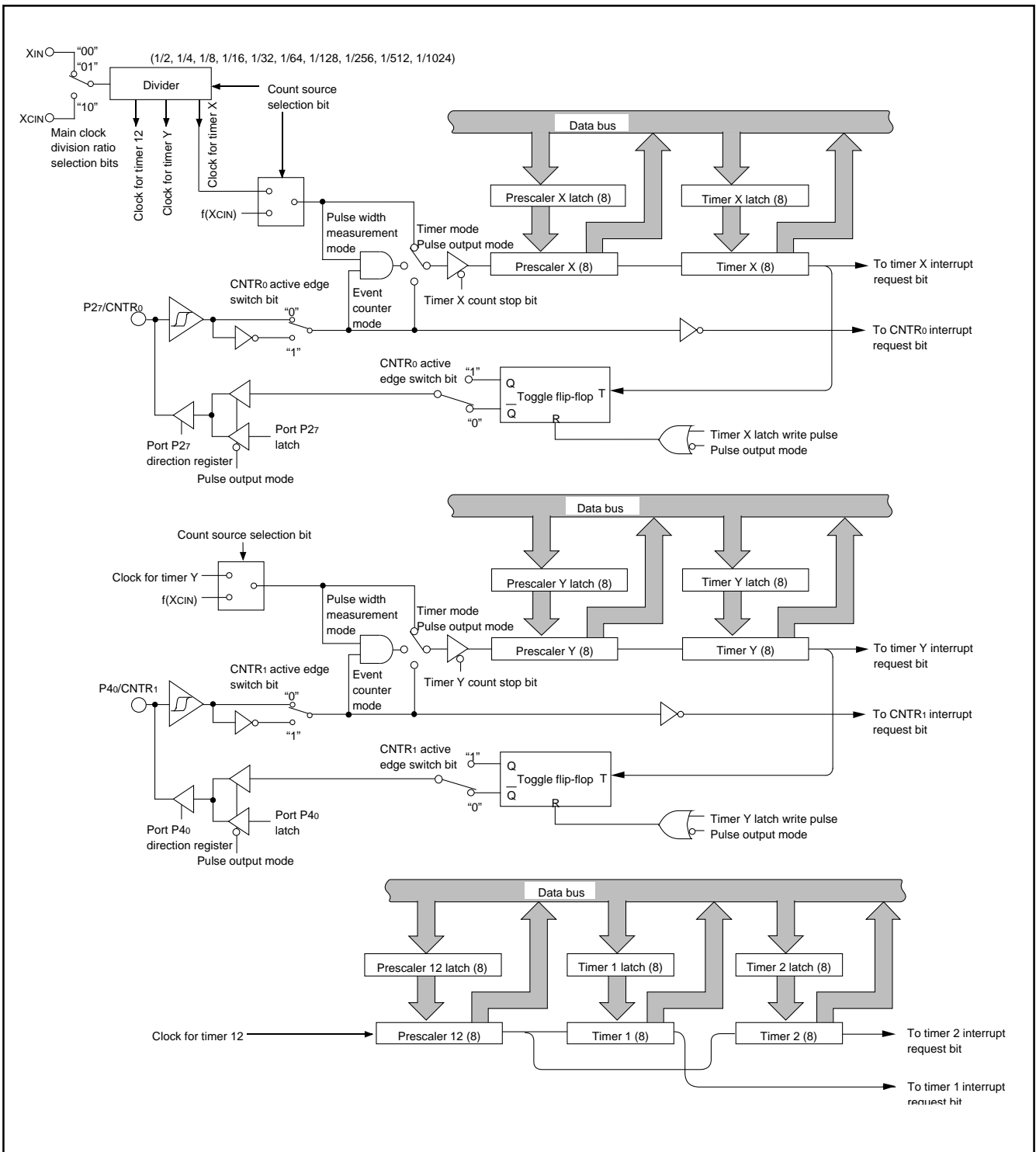

Fig. 17 Block diagram of timer X, timer Y, timer 1, and timer 2



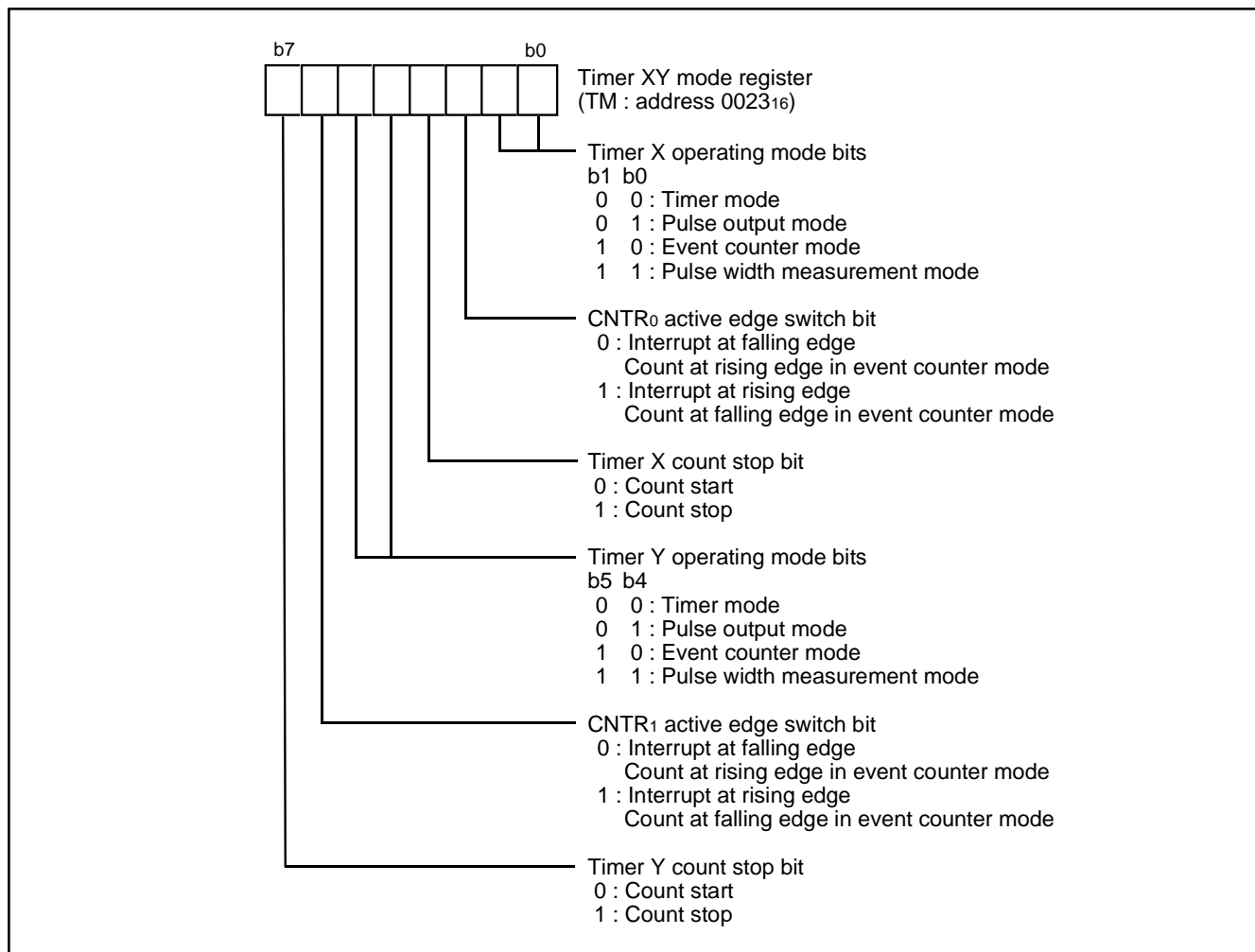

Fig. 18 Structure of timer XY mode register

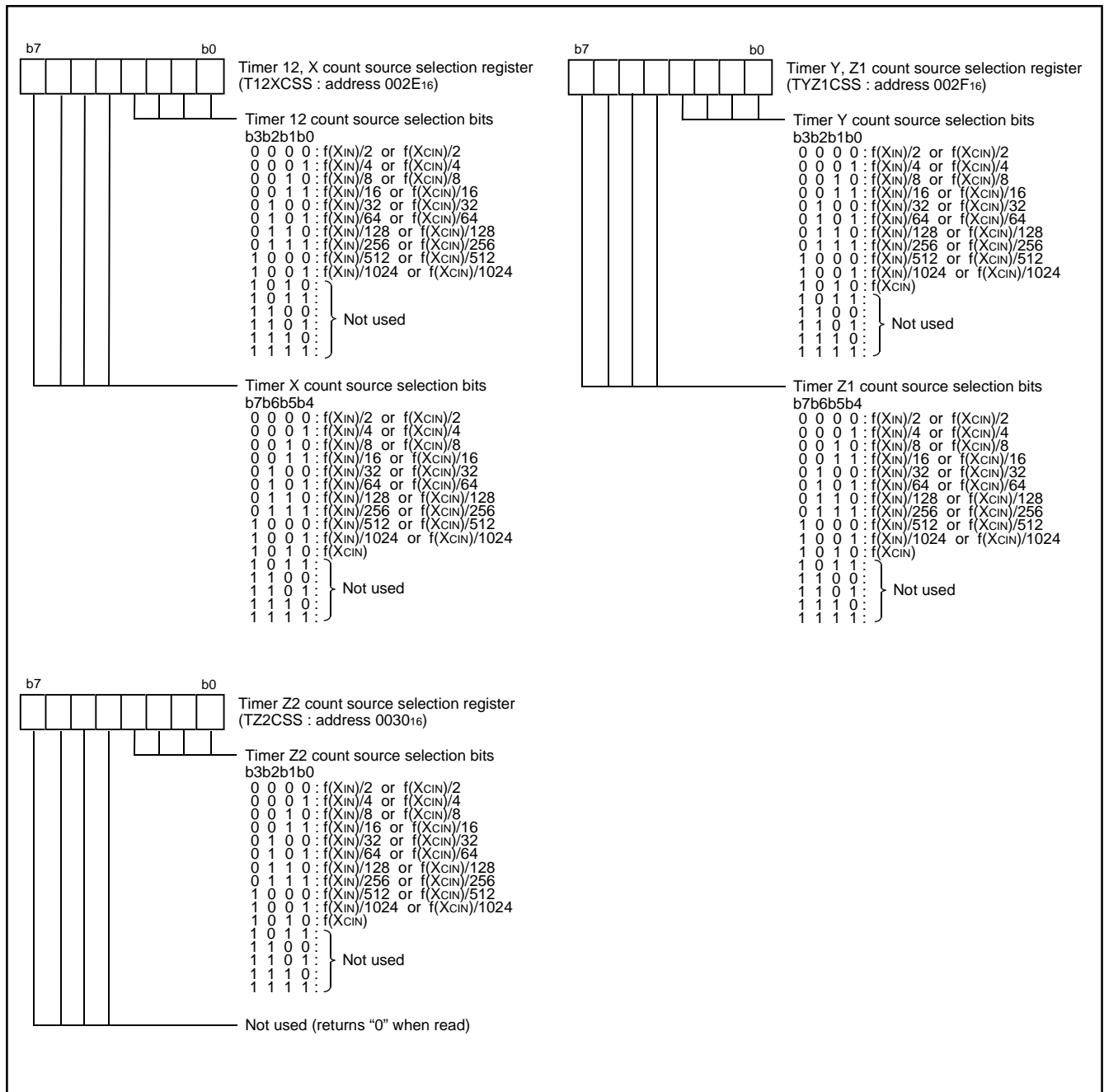

Fig. 19 Structure of timer 12, X, timer Y, Z1 and timer Z2 count source selection registers

## Timer Z1

### ●16-bit Timer

The timer Z1 is a 16-bit timer. When the timer reaches "0000<sub>16</sub>", an underflow occurs at the next count pulse and the corresponding timer latch is reloaded into the timer and the count is continued. When the timer underflows, the interrupt request bit corresponding to the timer Z1 is set to "1".

When reading/writing to the timer Z1, perform reading/writing to both the high-order byte and the low-order byte. When reading the timer Z1, read from the high-order byte first, followed by the low-order byte. Do not perform the writing to the timer Z1 between read operation of the high-order byte and read operation of the low-order byte. When writing to the timer Z1, write to the low-order byte first, followed by the high-order byte. Do not perform the reading to the timer Z1 between write operation of the low-order byte and write operation of the high-order byte.

The timer Z1 can select the count source by the timer Z1 count source selection bits of timer Y, Z count source selection register (bits 7 to 4 at address 000F<sub>16</sub>).

Timer Z1 can select one of seven operating modes by setting the timer Z1 mode register (address 0028<sub>16</sub>).

### (1) Timer mode

#### ●Mode selection

This mode can be selected by setting "000" to the timer Z1 operating mode bits (bits 2 to 0) and setting "0" to the timer/event counter mode switch bit (b7) of the timer Z1 mode register (address 0028<sub>16</sub>).

#### ●Count source selection

In high-, or middle-speed mode, 1/2, 1/4, 1/8, 1/16, 1/32, 1/64, 1/128, 1/256, 1/512 or 1/1024 of f(XIN); or f(XCIN) can be selected as the count source.

In low-speed mode, 1/2, 1/4, 1/8, 1/16, 1/32, 1/64, 1/128, 1/256, 1/512 or 1/1024 of f(XCIN); or f(XCIN) can be selected as the count source.

#### ●Interrupt

When an underflow occurs, the timer Z1/CNTR2 interrupt request bit (bit 0) of the interrupt request register 1 (address 003C<sub>16</sub>) is set to "1".

#### ●Explanation of operation

During timer stop, usually write data to a latch and a timer at the same time to set the timer value.

The timer count operation is started by setting "0" to the timer Z1 count stop bit (bit 6) of the timer Z1 mode register (address 0028<sub>16</sub>).

When the timer reaches "0000<sub>16</sub>", an underflow occurs at the next count pulse and the contents of timer latch are reloaded into the timer and the count is continued.

When writing data to the timer during operation, the data is written only into the latch. Then the new latch value is reloaded into the timer at the next underflow.

### (2) Event counter mode

#### ●Mode selection

This mode can be selected by setting "000" to the timer Z1 operating mode bits (bits 2 to 0) and setting "1" to the timer/event counter mode switch bit (bit 7) of the timer Z1 mode register (address 0028<sub>16</sub>).

The valid edge for the count operation depends on the CNTR2 active edge switch bit (bit 5) of the timer Z1 mode register (address 0028<sub>16</sub>). When it is "0", the rising edge is valid. When it is "1", the falling edge is valid.

#### ●Interrupt

The interrupt at an underflow is the same as the timer mode's.

#### ●Explanation of operation

The operation is the same as the timer mode's.

Set the double-function port of CNTR2 pin and port P22 to input in this mode.

Figure 22 shows the timing chart of the timer/event counter mode.

### (3) Pulse output mode

#### ●Mode selection

This mode can be selected by setting "001" to the timer Z1 operating mode bits (bits 2 to 0) and setting "0" to the timer/event counter mode switch bit (b7) of the timer Z1 mode register (address 0028<sub>16</sub>).

#### ●Count source selection

In high-, or middle-speed mode, 1/2, 1/4, 1/8, 1/16, 1/32, 1/64, 1/128, 1/256, 1/512 or 1/1024 of f(XIN); or f(XCIN) can be selected as the count source.

In low-speed mode, 1/2, 1/4, 1/8, 1/16, 1/32, 1/64, 1/128, 1/256, 1/512 or 1/1024 of f(XCIN); or f(XCIN) can be selected as the count source.

#### ●Interrupt

The interrupt at an underflow is the same as the timer mode's.

#### ●Explanation of operation

The operation is the same as the timer mode's. Moreover the pulse which is inverted each time the timer underflows is output from CNTR2 pin. When the CNTR2 active edge switch bit (bit 5) of the timer Z1 mode register (address 0028<sub>16</sub>) is "0", the output starts with "H" level. When it is "1", the output starts with "L" level.

#### ■Precautions

The double-function port of CNTR2 pin and port P22 is automatically set to the timer pulse output port in this mode.

The output from CNTR2 pin is initialized to the level depending on CNTR2 active edge switch bit by writing to the timer.

When the value of the CNTR2 active edge switch bit is changed, the output level of CNTR2 pin is inverted.

Figure 23 shows the timing chart of the pulse output mode.

#### (4) Pulse period measurement mode

##### ●Mode selection

This mode can be selected by setting "010" to the timer Z1 operating mode bits (bits 2 to 0) and setting "0" to the timer/event counter mode switch bit (b7) of the timer Z1 mode register (address 002816).

##### ●Count source selection

In high-, or middle-speed mode, 1/2, 1/4, 1/8, 1/16, 1/32, 1/64, 1/128, 1/256, 1/512 or 1/1024 of  $f(XIN)$ ; or  $f(XCIN)$  can be selected as the count source.

In low-speed mode, 1/2, 1/4, 1/8, 1/16, 1/32, 1/64, 1/128, 1/256, 1/512 or 1/1024 of  $f(XCIN)$ ; or  $f(XCIN)$  can be selected as the count source.

##### ●Interrupt

The interrupt at an underflow is the same as the timer mode's. When the pulse period measurement is completed, the timer Z1/CNTR2 interrupt request bit (bit 1) of the interrupt request register 1 (address 003C16) is set to "1".

##### ●Explanation of operation

The cycle of the pulse which is input from the CNTR2 pin is measured. When the CNTR2 active edge switch bit (bit 5) of the timer Z1 mode register (address 002816) is "0", the timer counts during the term from one falling edge of CNTR2 pin input to the next falling edge. When it is "1", the timer counts during the term from one rising edge input to the next rising edge input.

When the valid edge of measurement completion/start is detected, the 1's complement of the timer value is written to the timer latch and "FFFF16" is set to the timer.

Furthermore when the timer underflows, the timer Z1 interrupt request occurs and "FFFF16" is set to the timer. When reading the timer Z1, the value of the timer latch (measured value) is read. The measured value is retained until the next measurement completion.

##### ■Precautions

Set the double-function port of CNTR2 pin and port P22 to input in this mode.

A read-out of timer value is impossible in this mode. The timer can be written to only during timer stop (no measurement of pulse period).

Since the timer latch in this mode is specialized for the read-out of measured values, do not perform any write operation during measurement.

"FFFF16" is set to the timer when the timer underflows or when the valid edge of measurement start/completion is detected. Consequently, the timer value at start of pulse period measurement depends on the timer value just before measurement start.

Figure 24 shows the timing chart of the pulse period measurement mode.

#### (5) Pulse width measurement mode

##### ●Mode selection

This mode can be selected by setting "011" to the timer Z1 operating mode bits (bits 2 to 0) and setting "0" to the timer/event counter mode switch bit (b7) of the timer Z1 mode register (address 002816).

##### ●Count source selection

In high-, or middle-speed mode, 1/2, 1/4, 1/8, 1/16, 1/32, 1/64, 1/128, 1/256, 1/512 or 1/1024 of  $f(XIN)$ ; or  $f(XCIN)$  can be selected as the count source.

In low-speed mode, 1/2, 1/4, 1/8, 1/16, 1/32, 1/64, 1/128, 1/256, 1/512 or 1/1024 of  $f(XCIN)$ ; or  $f(XCIN)$  can be selected as the count source.

##### ●Interrupt

The interrupt at an underflow is the same as the timer mode's. When the pulse widths measurement is completed, the timer Z1/CNTR2 interrupt request bit (bit 1) of the interrupt request register 2 (address 003C16) is set to "1".

##### ●Explanation of operation

The pulse width which is input from the CNTR2 pin is measured. When the CNTR2 active edge switch bit (bit 5) of the timer Z1 mode register (address 002816) is "0", the timer counts during the term from one rising edge input to the next falling edge input ("H" term). When it is "1", the timer counts during the term from one falling edge of CNTR2 pin input to the next rising edge of input ("L" term).

When the valid edge of measurement completion is detected, the 1's complement of the timer value is written to the timer latch.

When the valid edge of measurement completion/start is detected, "FFFF16" is set to the timer.

When the timer Z1 underflows, the timer Z1 interrupt occurs and "FFFF16" is set to the timer Z1. When reading the timer Z1, the value of the timer latch (measured value) is read. The measured value is retained until the next measurement completion.

##### ■Precautions

Set the double-function port of CNTR2 pin and port P22 to input in this mode.

A read-out of timer value is impossible in this mode. The timer can be written to only during timer stop (no measurement of pulse widths).

Since the timer latch in this mode is specialized for the read-out of measured values, do not perform any write operation during measurement.

"FFFF16" is set to the timer when the timer underflows or when the valid edge of measurement start/completion is detected. Consequently, the timer value at start of pulse width measurement depends on the timer value just before measurement start.

Figure 25 shows the timing chart of the pulse width measurement mode.

## (6) Programmable waveform generating mode

### ●Mode selection

This mode can be selected by setting "100" to the timer Z1 operating mode bits (bits 2 to 0) and setting "0" to the timer/event counter mode switch bit (b7) of the timer Z1 mode register (address 002816).

### ●Count source selection

In high-, or middle-speed mode, 1/2, 1/4, 1/8, 1/16, 1/32, 1/64, 1/128, 1/256, 1/512 or 1/1024 of  $f(XIN)$ ; or  $f(XCIN)$  can be selected as the count source.

In low-speed mode, 1/2, 1/4, 1/8, 1/16, 1/32, 1/64, 1/128, 1/256, 1/512 or 1/1024 of  $f(XCIN)$ ; or  $f(XCIN)$  can be selected as the count source.

### ●Interrupt

The interrupt at an underflow is the same as the timer mode's.

### ●Explanation of operation

The operation is the same as the timer mode's. Moreover the timer outputs the data set in the output level latch (bit 4) of the timer Z1 mode register (address 002816) from the CNTR2 pin each time the timer underflows.

Changing the value of the output level latch and the timer latch after an underflow makes it possible to output an optional waveform from the CNTR2 pin.

### ■Precautions

The double-function port of CNTR2 pin and port P22 is automatically set to the programmable waveform generating port in this mode.

Figure 26 shows the timing chart of the programmable waveform generating mode.

## (7) Programmable one-shot generating mode

### ●Mode selection

This mode can be selected by setting "101" to the timer Z1 operating mode bits (bits 2 to 0) and setting "0" to the timer/event counter mode switch bit (b7) of the timer Z1 mode register (address 002816).

### ●Count source selection

In high-, or middle-speed mode, 1/2, 1/4, 1/8, 1/16, 1/32, 1/64, 1/128, 1/256, 1/512 or 1/1024 of  $f(XIN)$ ; or  $f(XCIN)$  can be selected as the count source.

### ●Interrupt

The interrupt at an underflow is the same as the timer mode's.

The trigger to generate one-shot pulse can be selected by the INT1 active edge selection bit (bit 1) of the interrupt edge selection register (address 003A16). When it is "0", the falling edge active is selected; when it is "1", the rising edge active is selected.

When the valid edge of the INT1 pin is detected, the INT1 interrupt request bit (bit 1) of the interrupt request register 1 (address 003C16) is set to "1".

### ●Explanation of operation

•"H" one-shot pulse; Bit 5 of timer Z1 mode register = "0"

The output level of the CNTR2 pin is initialized to "L" at mode selection. When trigger generation (input signal to INT1 pin) is detected, "H" is output from the CNTR2 pin. When an underflow occurs, "L" is output. The "H" one-shot pulse width is set by the setting value to the timer Z1 register low-order and high-order. When trigger generating is detected during timer count stop, al-

though "H" is output from the CNTR2 pin, "H" output state continues because an underflow does not occur.

•"L" one-shot pulse; Bit 5 of timer Z1 mode register = "1"

The output level of the CNTR2 pin is initialized to "H" at mode selection. When trigger generation (input signal to INT1 pin) is detected, "L" is output from the CNTR2 pin. When an underflow occurs, "H" is output. The "L" one-shot pulse width is set by the setting value to the timer Z1 low-order and high-order. When trigger generating is detected during timer count stop, although "L" is output from the CNTR2 pin, "L" output state continues because an underflow does not occur.

### ■Precautions

Set the double-function port of INT1 pin and port P42 to input in this mode.

Set the double function port of CNTR2 pin and port P22 is automatically set to the programmable one-shot generating port in this mode.

This mode cannot be used in low-speed mode.

If the value of the CNTR2 active edge switch bit is changed during one-shot generating enabled or generating one-shot pulse, then the output level from CNTR2 pin changes.

Figure 27 shows the timing chart of the programmable one-shot generating mode.

## ■Notes regarding all modes

### ●Timer Z1 write control

Which write control can be selected by the timer Z1 write control bit (bit 3) of the timer Z1 mode register (address 002816), writing data to both the latch and the timer at the same time or writing data only to the latch.

When the operation "writing data only to the latch" is selected, the value is set to the timer latch by writing data to the address of timer Z1 and the timer is updated at next underflow. After reset release, the operation "writing data to both the latch and the timer at the same time" is selected, and the value is set to both the latch and the timer at the same time by writing data to the address of timer Z1.

In the case of writing data only to the latch, if writing data to the latch and an underflow are performed almost at the same time, the timer value may become undefined.

### ●Timer Z1 read control

A read-out of timer value is impossible in pulse period measurement mode and pulse width measurement mode. In the other modes, a read-out of timer value is possible regardless of count operating or stopped.

However, a read-out of timer latch value is impossible.

### ●Switch of interrupt active edge of CNTR2 and INT1

Each interrupt active edge depends on setting of the CNTR2 active edge switch bit and the INT1 active edge selection bit.

### ●Switch of count source

When switching the count source by the timer Z1 count source selection bits, the value of timer count is altered in inconsiderable amount owing to generating of thin pulses on the count input signals.

Therefore, select the timer count source before setting the value to the prescaler and the timer.

### ●Usage of CNTR2 pin as normal I/O port P22

To use the CNTR2 pin as normal I/O port P22, set timer Z1 operating mode bits (b2, b1, b0) of timer Z1 mode register (address 002816) to "000".

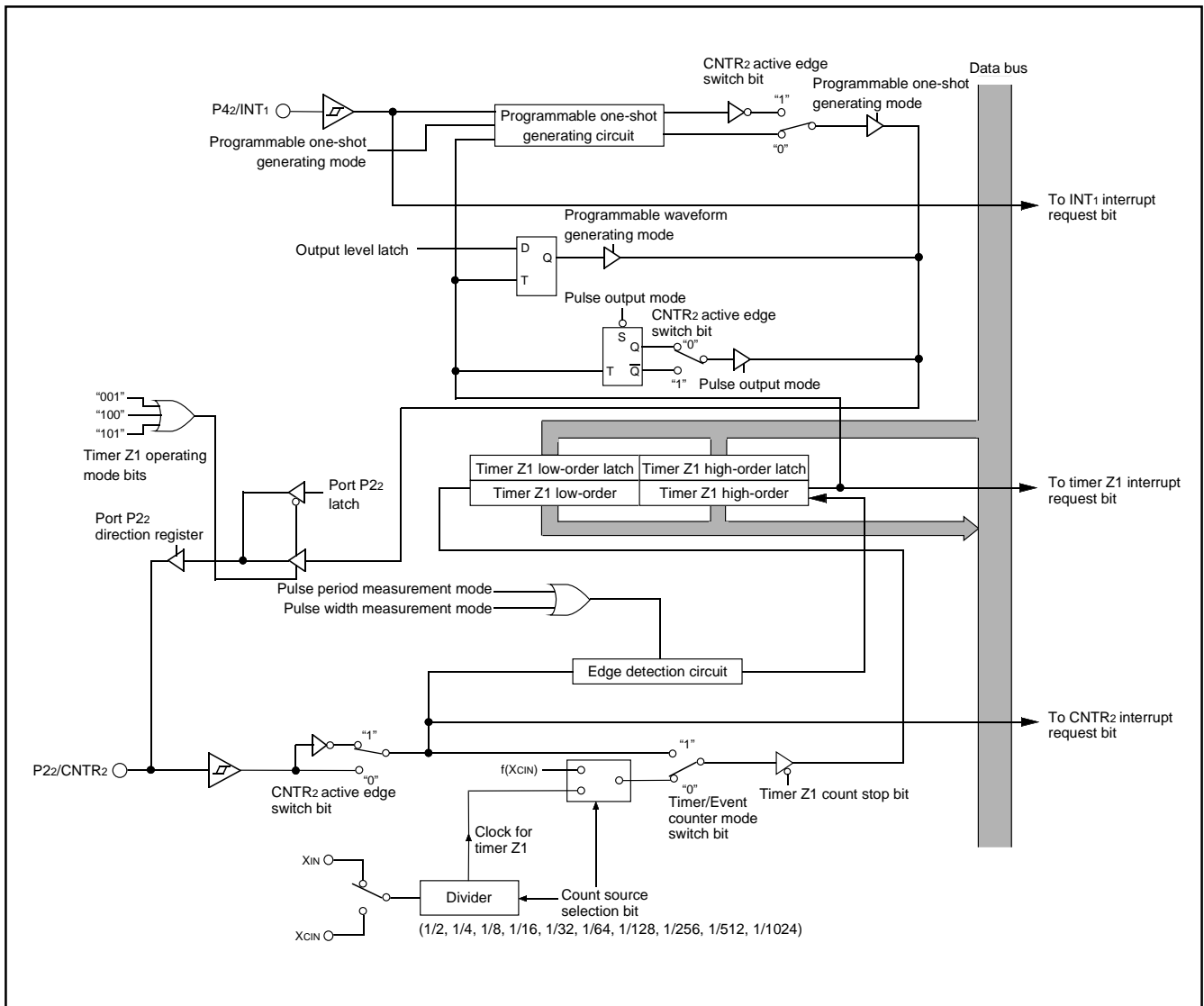

Fig. 20 Block diagram of timer Z1

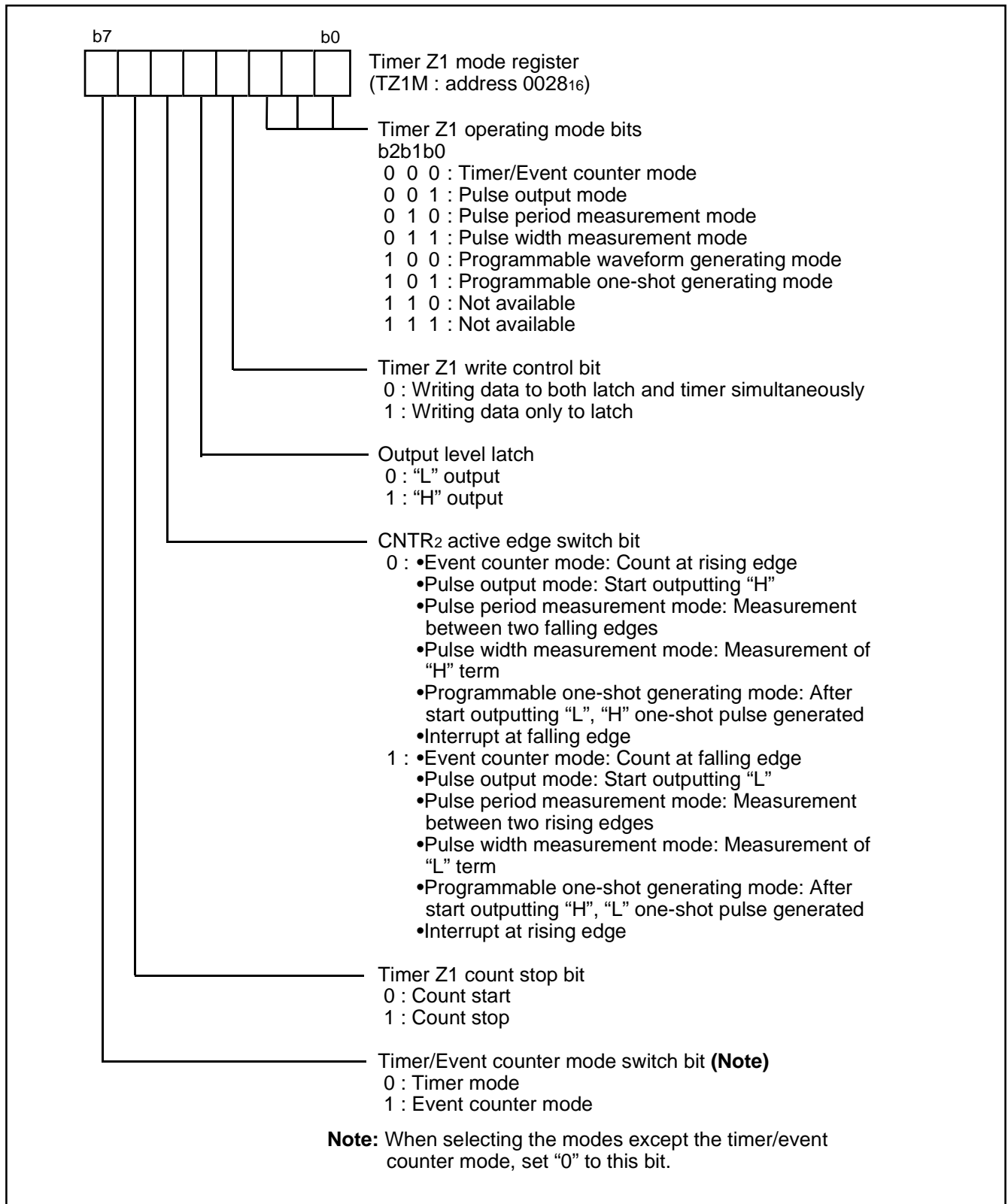

Fig. 21 Structure of timer Z1 mode register

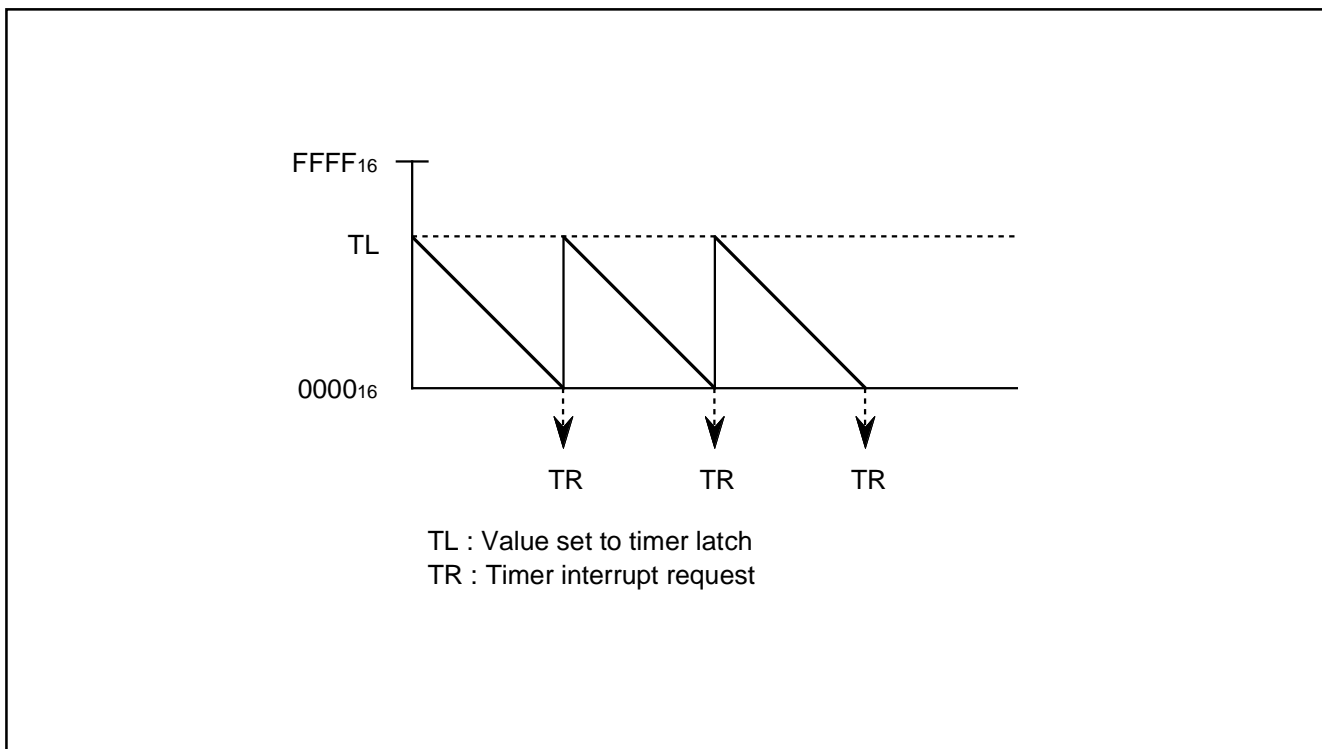

Fig. 22 Timing chart of timer/event counter mode

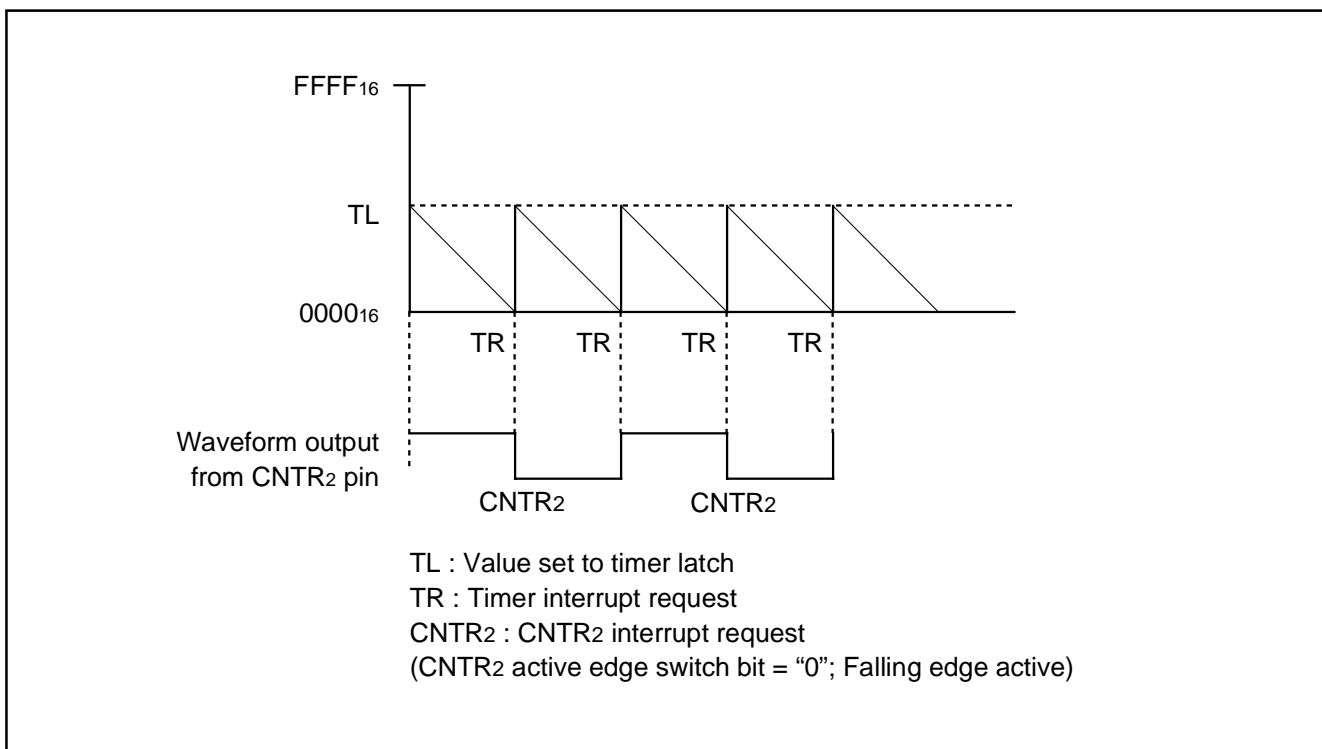

Fig. 23 Timing chart of pulse output mode



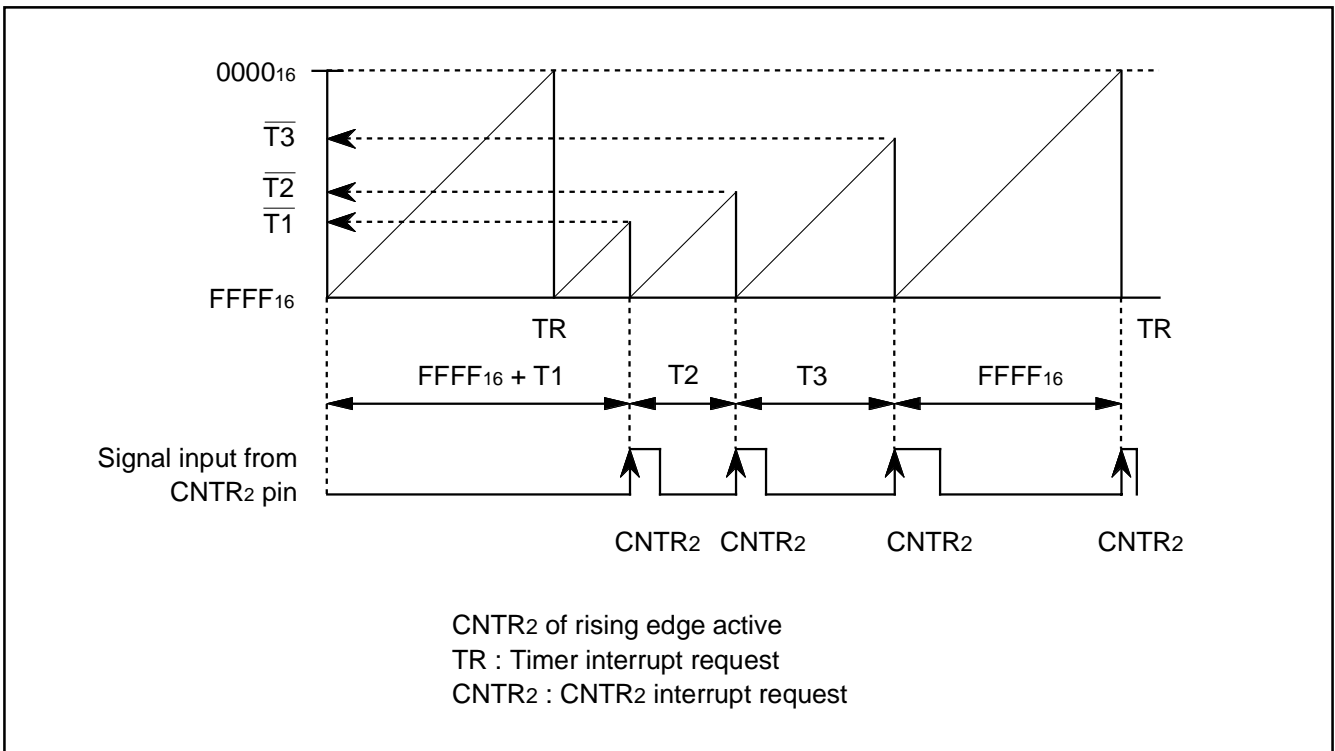

Fig. 24 Timing chart of pulse period measurement mode (Measuring term between two rising edges)

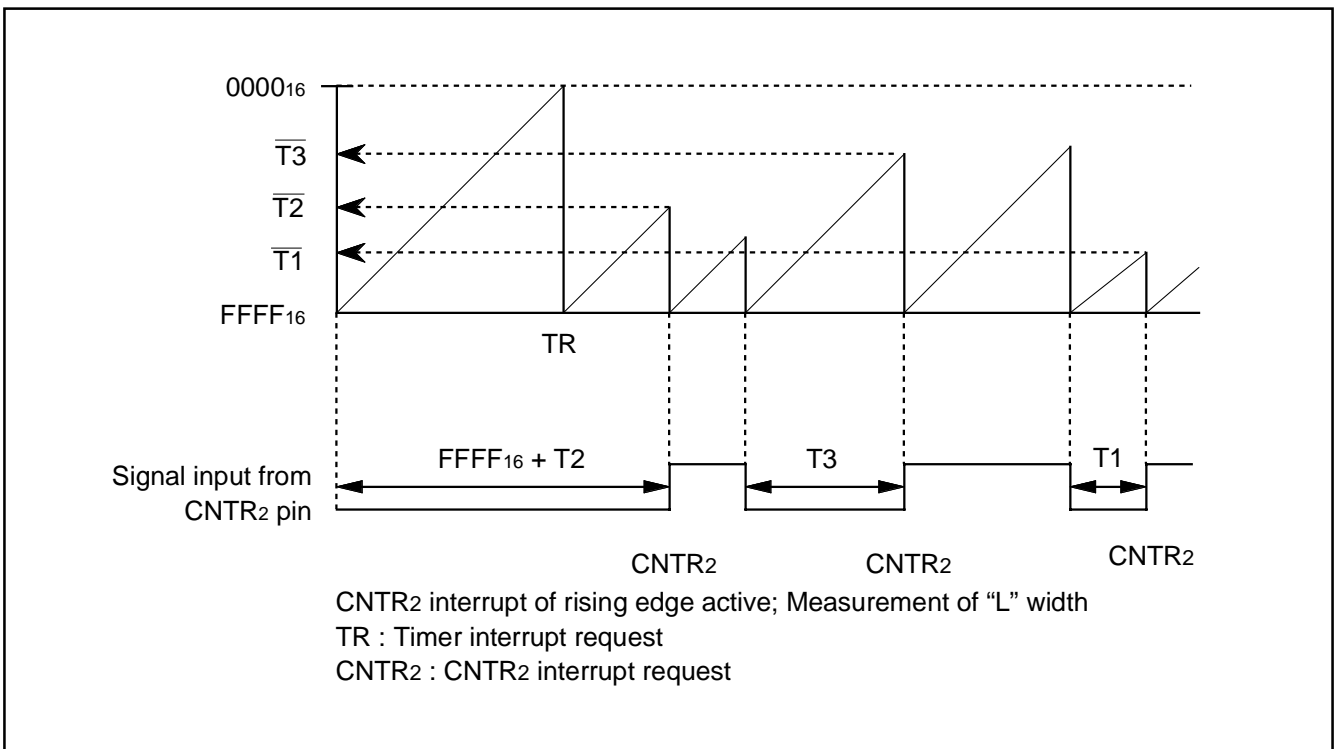

Fig. 25 Timing chart of pulse width measurement mode (Measuring "L" term)

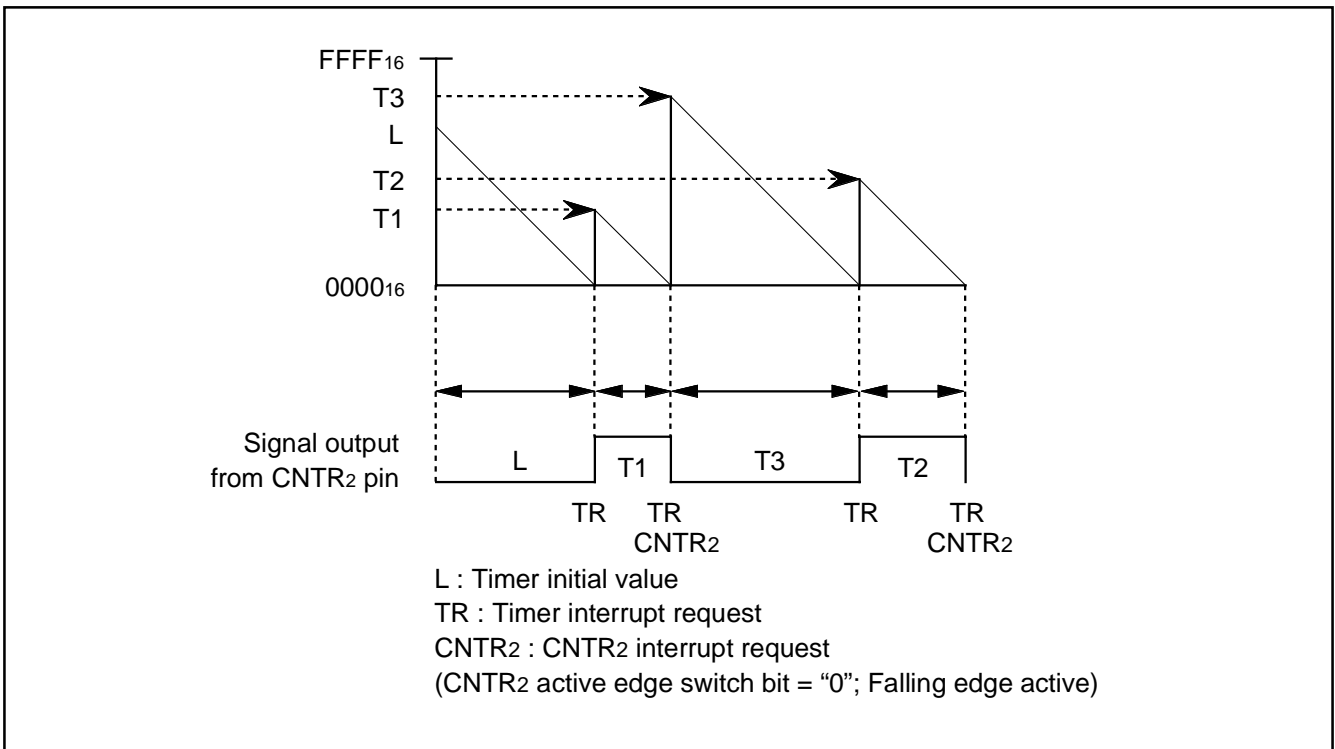

Fig. 26 Timing chart of programmable waveform generating mode

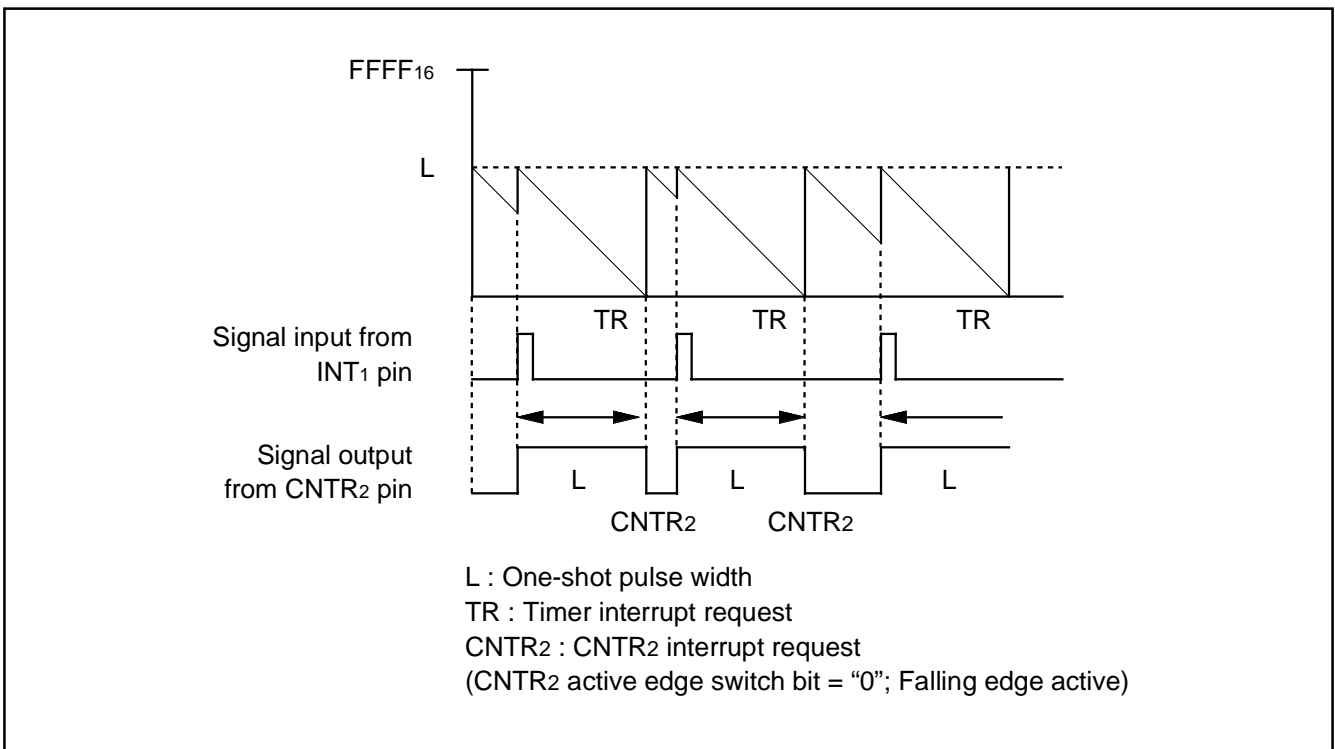

Fig. 27 Timing chart of programmable one-shot generating mode ("H" one-shot pulse generating)

## Timer Z2

### ●16-bit Timer

The timer Z2 is a 16-bit timer. When the timer reaches "0000<sub>16</sub>", an underflow occurs at the next count pulse and the corresponding timer latch is reloaded into the timer and the count is continued. When the timer underflows, the interrupt request bit corresponding to the timer Z2 is set to "1".

When reading/writing to the timer Z2, perform reading/writing to both the high-order byte and the low-order byte. When reading the timer Z2, read from the high-order byte first, followed by the low-order byte. Do not perform the writing to the timer Z2 between read operation of the high-order byte and read operation of the low-order byte. When writing to the timer Z2, write to the low-order byte first, followed by the high-order byte. Do not perform the reading to the timer Z2 between write operation of the low-order byte and write operation of the high-order byte.

The timer Z2 can select the count source by the timer Z2 count source selection bits of timer Z2 count source selection register (bits 7 to 4 at address 0030<sub>16</sub>).

Timer Z2 can select one of seven operating modes by setting the timer Z2 mode register (address 002B<sub>16</sub>).

### (1) Timer mode

#### ●Mode selection

This mode can be selected by setting "000" to the timer Z2 operating mode bits (bits 2 to 0) and setting "0" to the timer/event counter mode switch bit (b7) of the timer Z2 mode register (address 002B<sub>16</sub>).

#### ●Count source selection

In high-, or middle-speed mode, 1/2, 1/4, 1/8, 1/16, 1/32, 1/64, 1/128, 1/256, 1/512 or 1/1024 of f(XIN); or f(XCIN) can be selected as the count source.

In low-speed mode, 1/2, 1/4, 1/8, 1/16, 1/32, 1/64, 1/128, 1/256, 1/512 or 1/1024 of f(XCIN); or f(XCIN) can be selected as the count source.

#### ●Interrupt

When an underflow occurs, the timer Z2/CNTR3 interrupt request bit (bit 5) of the interrupt request register 1 (address 003C<sub>16</sub>) is set to "1".

#### ●Explanation of operation

During timer stop, usually write data to a latch and a timer at the same time to set the timer value.

The timer count operation is started by setting "0" to the timer Z2 count stop bit (bit 6) of the timer Z2 mode register (address 002B<sub>16</sub>).

When the timer reaches "0000<sub>16</sub>", an underflow occurs at the next count pulse and the contents of timer latch are reloaded into the timer and the count is continued.

When writing data to the timer during operation, the data is written only into the latch. Then the new latch value is reloaded into the timer at the next underflow.

### (2) Event counter mode

#### ●Mode selection

This mode can be selected by setting "000" to the timer Z2 operating mode bits (bits 2 to 0) and setting "1" to the timer/event counter mode switch bit (bit 7) of the timer Z2 mode register (address 002B<sub>16</sub>).

The valid edge for the count operation depends on the CNTR3 active edge switch bit (bit 5) of the timer Z2 mode register (address 002B<sub>16</sub>). When it is "0", the rising edge is valid. When it is "1", the falling edge is valid.

#### ●Interrupt

The interrupt at an underflow is the same as the timer mode's.

#### ●Explanation of operation

The operation is the same as the timer mode's.

Set the double-function port of CNTR3 pin and port P23 to input in this mode.

Figure 30 shows the timing chart of the timer/event counter mode.

### (3) Pulse output mode

#### ●Mode selection

This mode can be selected by setting "001" to the timer Z2 operating mode bits (bits 2 to 0) and setting "0" to the timer/event counter mode switch bit (b7) of the timer Z2 mode register (address 002B<sub>16</sub>).

#### ●Count source selection

In high-, or middle-speed mode, 1/2, 1/4, 1/8, 1/16, 1/32, 1/64, 1/128, 1/256, 1/512 or 1/1024 of f(XIN); or f(XCIN) can be selected as the count source.

In low-speed mode, 1/2, 1/4, 1/8, 1/16, 1/32, 1/64, 1/128, 1/256, 1/512 or 1/1024 of f(XCIN); or f(XCIN) can be selected as the count source.

#### ●Interrupt

The interrupt at an underflow is the same as the timer mode's.

#### ●Explanation of operation

The operation is the same as the timer mode's. Moreover the pulse which is inverted each time the timer underflows is output from CNTR3 pin. When the CNTR3 active edge switch bit (bit 5) of the timer Z2 mode register (address 002B<sub>16</sub>) is "0", the output starts with "H" level. When it is "1", the output starts with "L" level.

#### ■Precautions

The double-function port of CNTR3 pin and port P23 is automatically set to the timer pulse output port in this mode.

The output from CNTR3 pin is initialized to the level depending on CNTR3 active edge switch bit by writing to the timer.

When the value of the CNTR3 active edge switch bit is changed, the output level of CNTR3 pin is inverted.

Figure 31 shows the timing chart of the pulse output mode.

#### (4) Pulse period measurement mode

##### ●Mode selection

This mode can be selected by setting "010" to the timer Z2 operating mode bits (bits 2 to 0) and setting "0" to the timer/event counter mode switch bit (b7) of the timer Z2 mode register (address 002B16).

##### ●Count source selection

In high-, or middle-speed mode, 1/2, 1/4, 1/8, 1/16, 1/32, 1/64, 1/128, 1/256, 1/512 or 1/1024 of  $f(XIN)$ ; or  $f(XCIN)$  can be selected as the count source.

In low-speed mode, 1/2, 1/4, 1/8, 1/16, 1/32, 1/64, 1/128, 1/256, 1/512 or 1/1024 of  $f(XCIN)$ ; or  $f(XCIN)$  can be selected as the count source.

##### ●Interrupt

The interrupt at an underflow is the same as the timer mode's. When the pulse period measurement is completed, the timer Z2/CNTR3 interrupt request bit (bit 1) of the interrupt request register 1 (address 003C16) is set to "1".

##### ●Explanation of operation

The cycle of the pulse which is input from the CNTR3 pin is measured. When the CNTR3 active edge switch bit (bit 5) of the timer Z2 mode register (address 002B16) is "0", the timer counts during the term from one falling edge of CNTR3 pin input to the next falling edge. When it is "1", the timer counts during the term from one rising edge input to the next rising edge input.

When the valid edge of measurement completion/start is detected, the 1's complement of the timer value is written to the timer latch and "FFFF16" is set to the timer.

Furthermore when the timer underflows, the timer Z2 interrupt request occurs and "FFFF16" is set to the timer. When reading the timer Z2, the value of the timer latch (measured value) is read. The measured value is retained until the next measurement completion.

##### ■Precautions

Set the double-function port of CNTR3 pin and port P23 to input in this mode.

A read-out of timer value is impossible in this mode. The timer can be written to only during timer stop (no measurement of pulse period).

Since the timer latch in this mode is specialized for the read-out of measured values, do not perform any write operation during measurement.

"FFFF16" is set to the timer when the timer underflows or when the valid edge of measurement start/completion is detected. Consequently, the timer value at start of pulse period measurement depends on the timer value just before measurement start.

Figure 32 shows the timing chart of the pulse period measurement mode.

#### (5) Pulse width measurement mode

##### ●Mode selection

This mode can be selected by setting "011" to the timer Z2 operating mode bits (bits 2 to 0) and setting "0" to the timer/event counter mode switch bit (b7) of the timer Z2 mode register (address 002B16).

##### ●Count source selection

In high-, or middle-speed mode, 1/2, 1/4, 1/8, 1/16, 1/32, 1/64, 1/128, 1/256, 1/512 or 1/1024 of  $f(XIN)$ ; or  $f(XCIN)$  can be selected as the count source.

In low-speed mode, 1/2, 1/4, 1/8, 1/16, 1/32, 1/64, 1/128, 1/256, 1/512 or 1/1024 of  $f(XCIN)$ ; or  $f(XCIN)$  can be selected as the count source.

##### ●Interrupt

The interrupt at an underflow is the same as the timer mode's. When the pulse widths measurement is completed, the timer Z2/CNTR3 interrupt request bit (bit 1) of the interrupt request register 1 (address 003C16) is set to "1".

##### ●Explanation of operation

The pulse width which is input from the CNTR3 pin is measured. When the CNTR3 active edge switch bit (bit 5) of the timer Z2 mode register (address 002B16) is "0", the timer counts during the term from one rising edge input to the next falling edge input ("H" term). When it is "1", the timer counts during the term from one falling edge of CNTR3 pin input to the next rising edge of input ("L" term).

When the valid edge of measurement completion is detected, the 1's complement of the timer value is written to the timer latch.

When the valid edge of measurement completion/start is detected, "FFFF16" is set to the timer.

When the timer Z2 underflows, the timer Z2 interrupt occurs and "FFFF16" is set to the timer Z2. When reading the timer Z2, the value of the timer latch (measured value) is read. The measured value is retained until the next measurement completion.

##### ■Precautions

Set the double-function port of CNTR3 pin and port P23 to input in this mode.

A read-out of timer value is impossible in this mode. The timer can be written to only during timer stop (no measurement of pulse widths).

Since the timer latch in this mode is specialized for the read-out of measured values, do not perform any write operation during measurement.

"FFFF16" is set to the timer when the timer underflows or when the valid edge of measurement start/completion is detected. Consequently, the timer value at start of pulse width measurement depends on the timer value just before measurement start.

Figure 33 shows the timing chart of the pulse width measurement mode.

## (6) Programmable waveform generating mode

### ●Mode selection

This mode can be selected by setting "100" to the timer Z2 operating mode bits (bits 2 to 0) and setting "0" to the timer/event counter mode switch bit (b7) of the timer Z2 mode register (address 002B16).

### ●Count source selection

In high-, or middle-speed mode, 1/2, 1/4, 1/8, 1/16, 1/32, 1/64, 1/128, 1/256, 1/512 or 1/1024 of  $f(XIN)$ ; or  $f(XCIN)$  can be selected as the count source.

In low-speed mode, 1/2, 1/4, 1/8, 1/16, 1/32, 1/64, 1/128, 1/256, 1/512 or 1/1024 of  $f(XCIN)$ ; or  $f(XCIN)$  can be selected as the count source.

### ●Interrupt

The interrupt at an underflow is the same as the timer mode's.

### ●Explanation of operation

The operation is the same as the timer mode's. Moreover the timer outputs the data set in the output level latch (bit 4) of the timer Z2 mode register (address 002B16) from the CNTR3 pin each time the timer underflows.

Changing the value of the output level latch and the timer latch after an underflow makes it possible to output an optional waveform from the CNTR3 pin.

### ■Precautions

The double-function port of CNTR3 pin and port P23 is automatically set to the programmable waveform generating port in this mode.

Figure 34 shows the timing chart of the programmable waveform generating mode.

## (7) Programmable one-shot generating mode

### ●Mode selection

This mode can be selected by setting "101" to the timer Z2 operating mode bits (bits 2 to 0) and setting "0" to the timer/event counter mode switch bit (b7) of the timer Z2 mode register (address 002B16).

### ●Count source selection

In high-, or middle-speed mode, 1/2, 1/4, 1/8, 1/16, 1/32, 1/64, 1/128, 1/256, 1/512 or 1/1024 of  $f(XIN)$ ; or  $f(XCIN)$  can be selected as the count source.

### ●Interrupt

The interrupt at an underflow is the same as the timer mode's.

The trigger to generate one-shot pulse can be selected by the INT2 active edge selection bit (bit 2) of the interrupt edge selection register (address 003A16). When it is "0", the falling edge active is selected; when it is "1", the rising edge active is selected.

When the valid edge of the INT2 pin is detected, the INT2 interrupt request bit (bit 2) of the interrupt request register 1 (address 003C16) is set to "1".

### ●Explanation of operation

•"H" one-shot pulse; Bit 5 of timer Z2 mode register = "0"

The output level of the CNTR3 pin is initialized to "L" at mode selection. When trigger generation (input signal to INT2 pin) is detected, "H" is output from the CNTR3 pin. When an underflow occurs, "L" is output. The "H" one-shot pulse width is set by the setting value to the timer Z2 register low-order and high-order. When trigger generating is detected during timer count stop, al-

though "H" is output from the CNTR3 pin, "H" output state continues because an underflow does not occur.

•"L" one-shot pulse; Bit 5 of timer Z2 mode register = "1"

The output level of the CNTR3 pin is initialized to "H" at mode selection. When trigger generation (input signal to INT2 pin) is detected, "L" is output from the CNTR3 pin. When an underflow occurs, "H" is output. The "L" one-shot pulse width is set by the setting value to the timer Z2 low-order and high-order. When trigger generating is detected during timer count stop, although "L" is output from the CNTR3 pin, "L" output state continues because an underflow does not occur.

### ■Precautions

Set the double-function port of INT2 pin and port P43 to input in this mode.

Set the double function port of CNTR3 pin and port P23 is automatically set to the programmable one-shot generating port in this mode.

This mode cannot be used in low-speed mode.

If the value of the CNTR3 active edge switch bit is changed during one-shot generating enabled or generating one-shot pulse, then the output level from CNTR3 pin changes.

Figure 35 shows the timing chart of the programmable one-shot generating mode.

## ■Notes regarding all modes

### ●Timer Z2 write control

Which write control can be selected by the timer Z2 write control bit (bit 3) of the timer Z2 mode register (address 002B16), writing data to both the latch and the timer at the same time or writing data only to the latch.

When the operation "writing data only to the latch" is selected, the value is set to the timer latch by writing data to the address of timer Z2 and the timer is updated at next underflow. After reset release, the operation "writing data to both the latch and the timer at the same time" is selected, and the value is set to both the latch and the timer at the same time by writing data to the address of timer Z2.

In the case of writing data only to the latch, if writing data to the latch and an underflow are performed almost at the same time, the timer value may become undefined.

### ●Timer Z2 read control

A read-out of timer value is impossible in pulse period measurement mode and pulse width measurement mode. In the other modes, a read-out of timer value is possible regardless of count operating or stopped.

However, a read-out of timer latch value is impossible.

### ●Switch of interrupt active edge of CNTR3 and INT2

Each interrupt active edge depends on setting of the CNTR3 active edge switch bit and the INT2 active edge selection bit.

### ●Switch of count source

When switching the count source by the timer Z2 count source selection bits, the value of timer count is altered in inconsiderable amount owing to generating of thin pulses on the count input signals.

Therefore, select the timer count source before setting the value to the prescaler and the timer.

### ●Usage of CNTR3 pin as normal I/O port P23

To use the CNTR3 pin as normal I/O port P23, set timer Z2 operating mode bits (b2, b1, b0) of timer Z2 mode register (address 002B16) to "000".

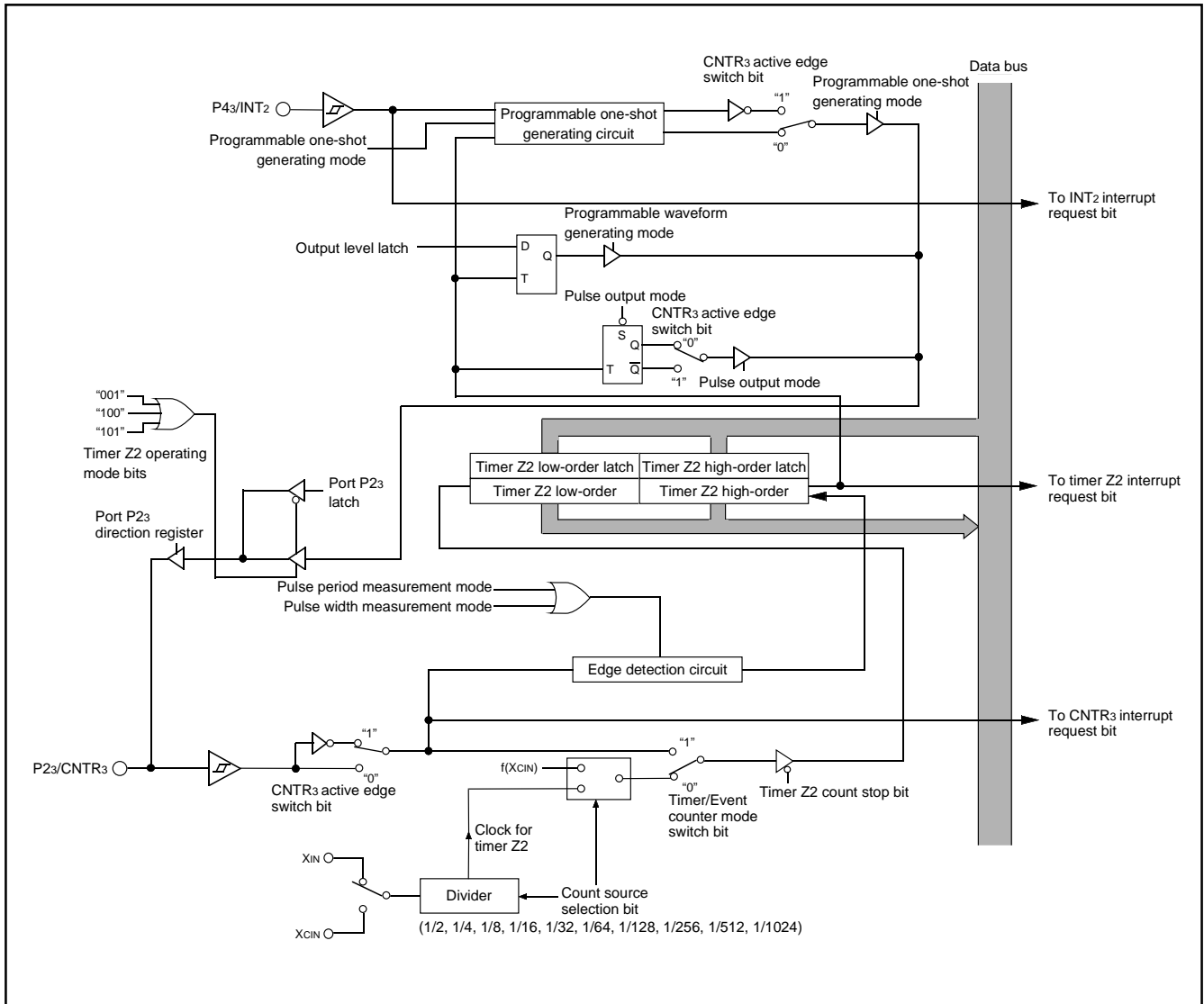

Fig. 28 Block diagram of timer Z2

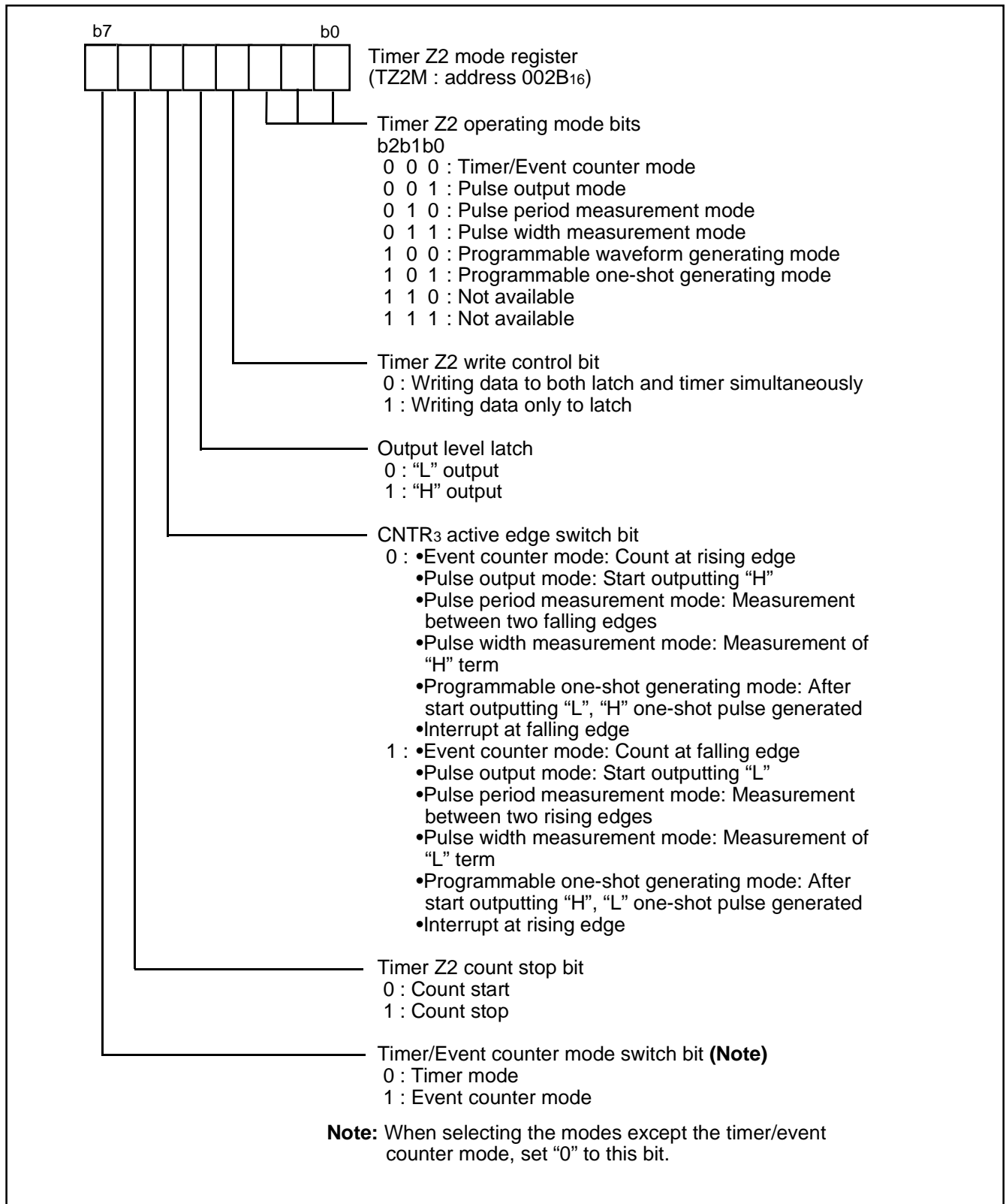

Fig. 29 Structure of timer Z2 mode register

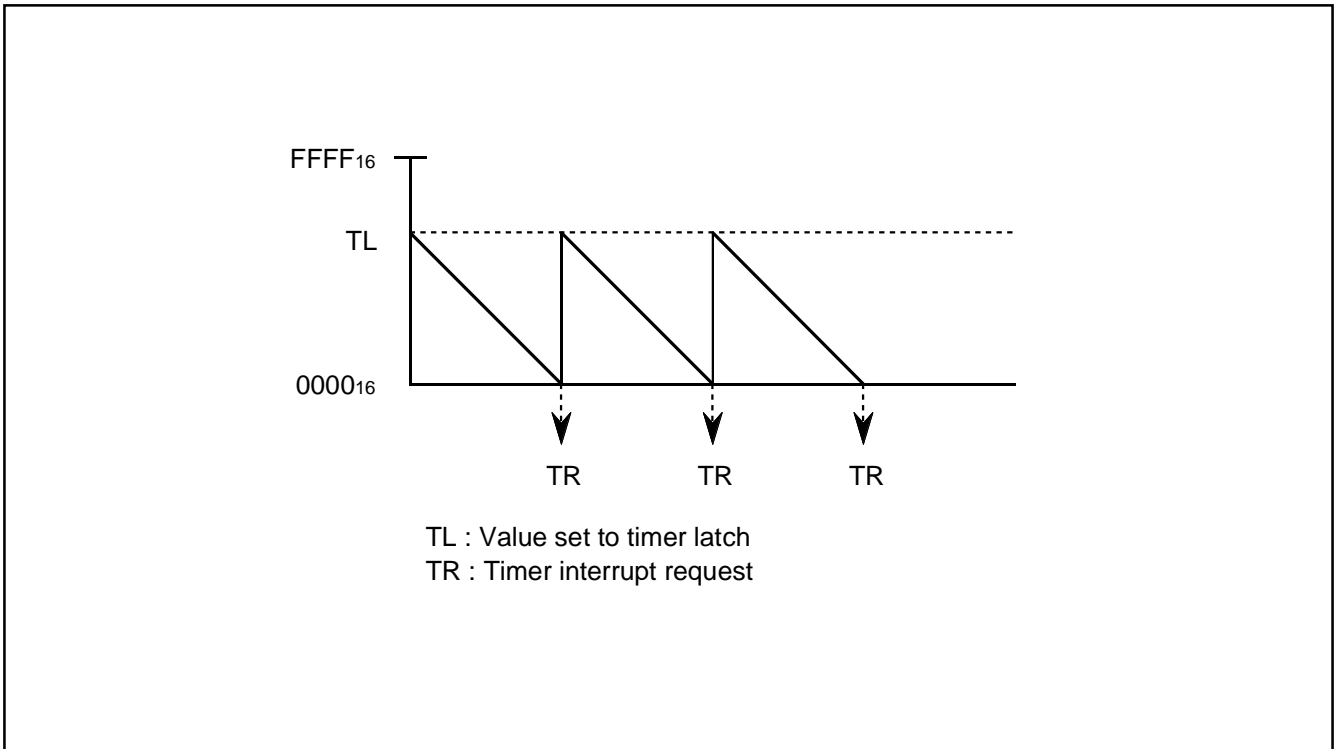

Fig. 30 Timing chart of timer/event counter mode

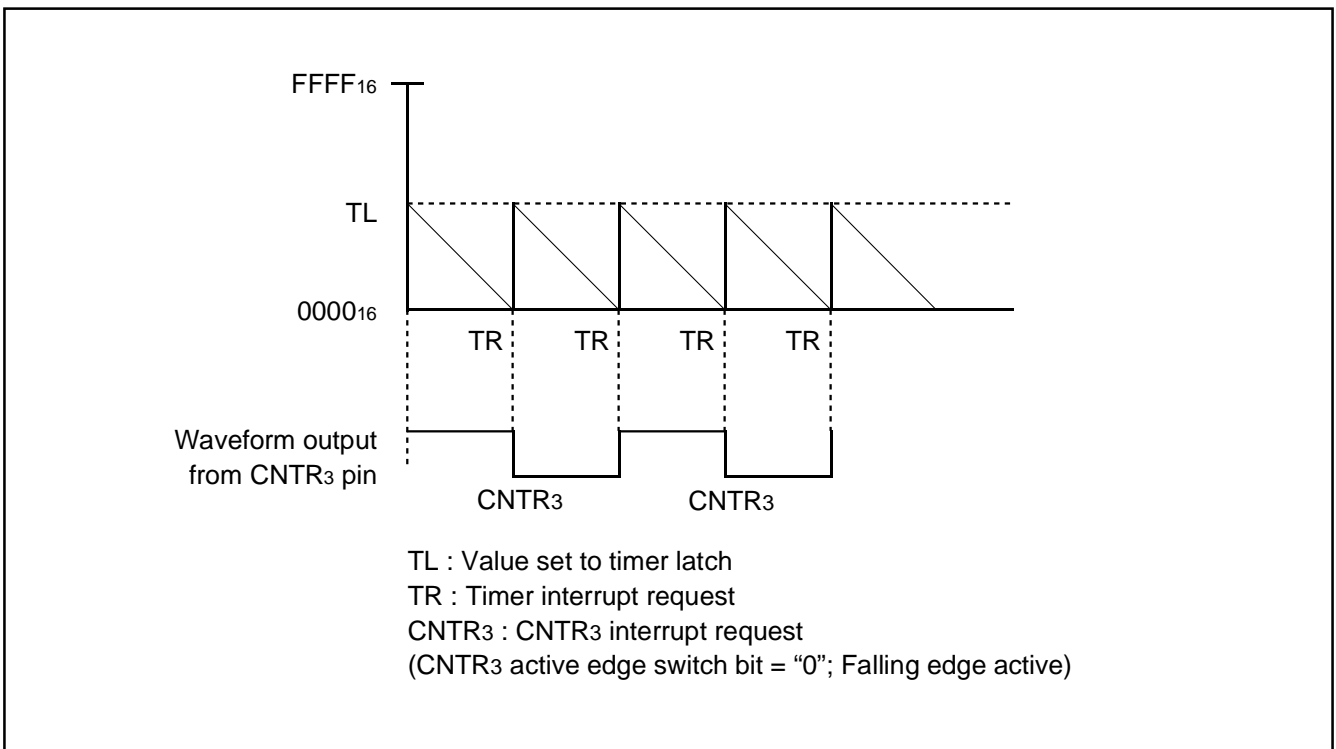

Fig. 31 Timing chart of pulse output mode



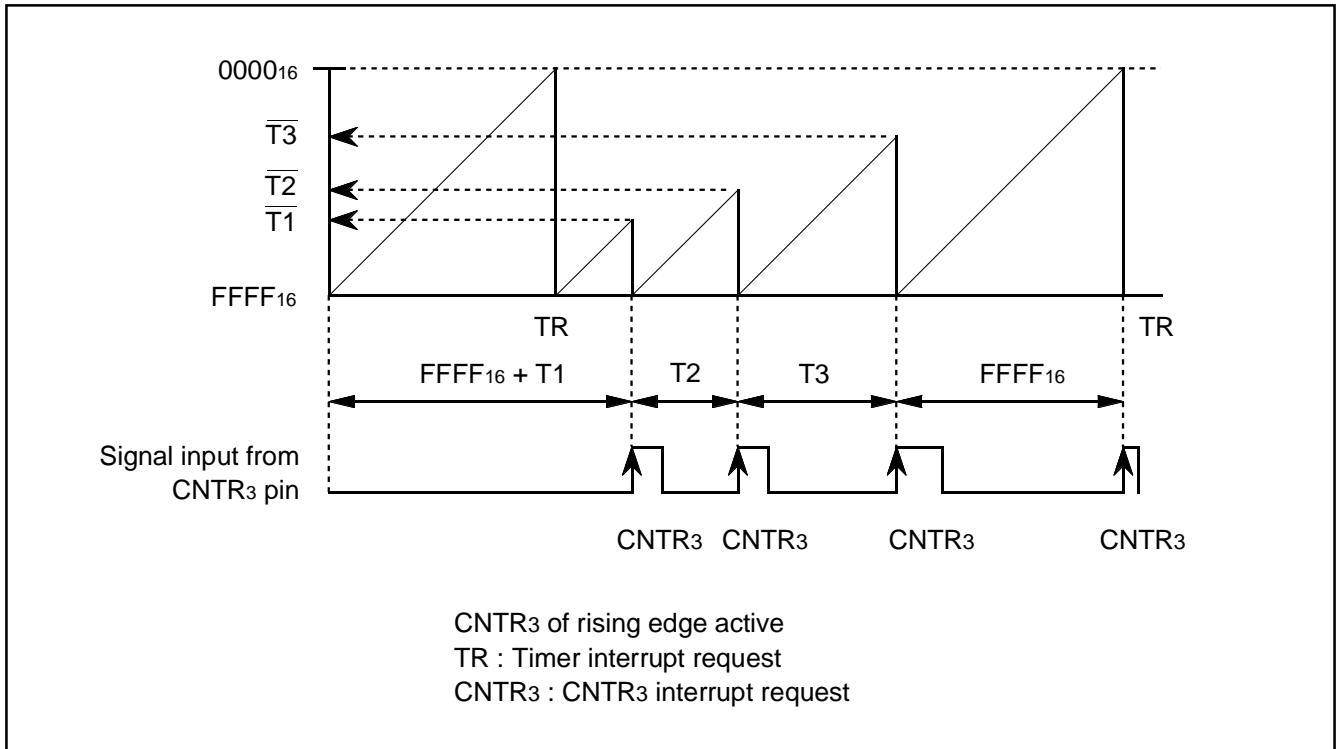

Fig. 32 Timing chart of pulse period measurement mode (Measuring term between two rising edges)

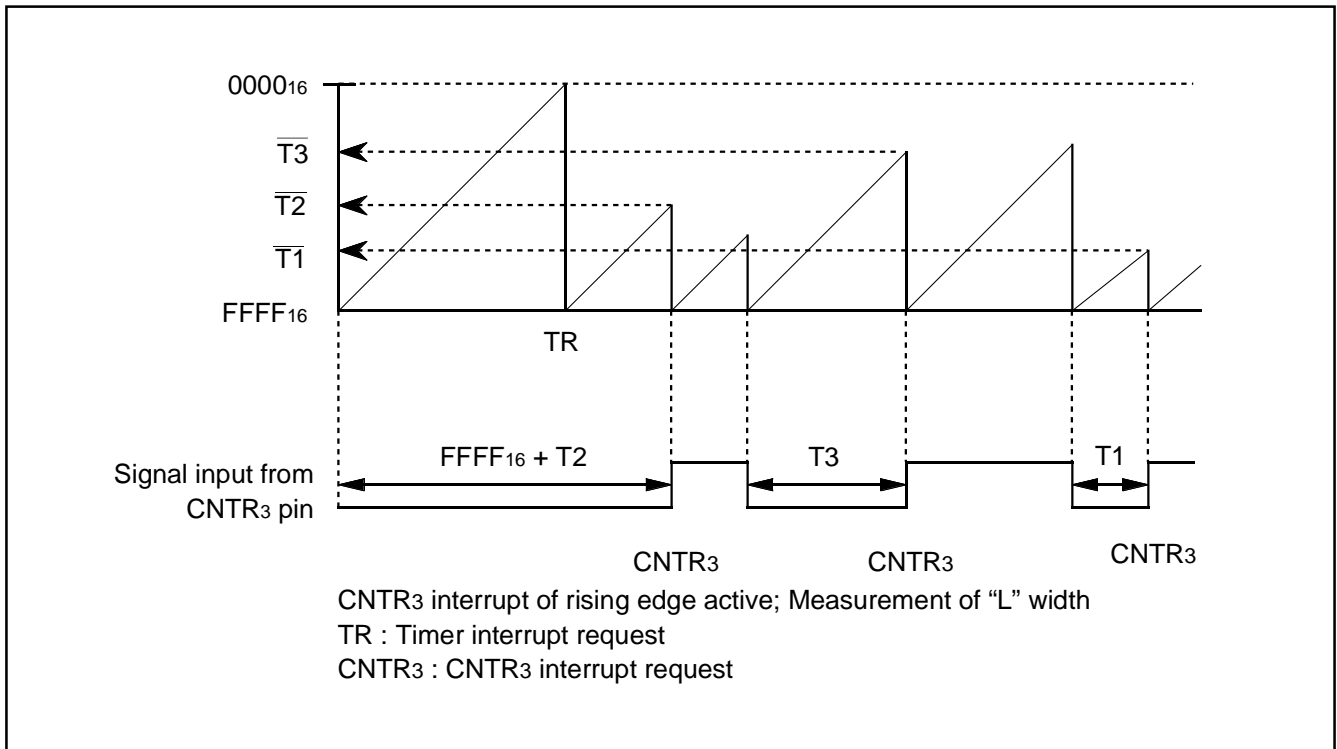

Fig. 33 Timing chart of pulse width measurement mode (Measuring "L" term)

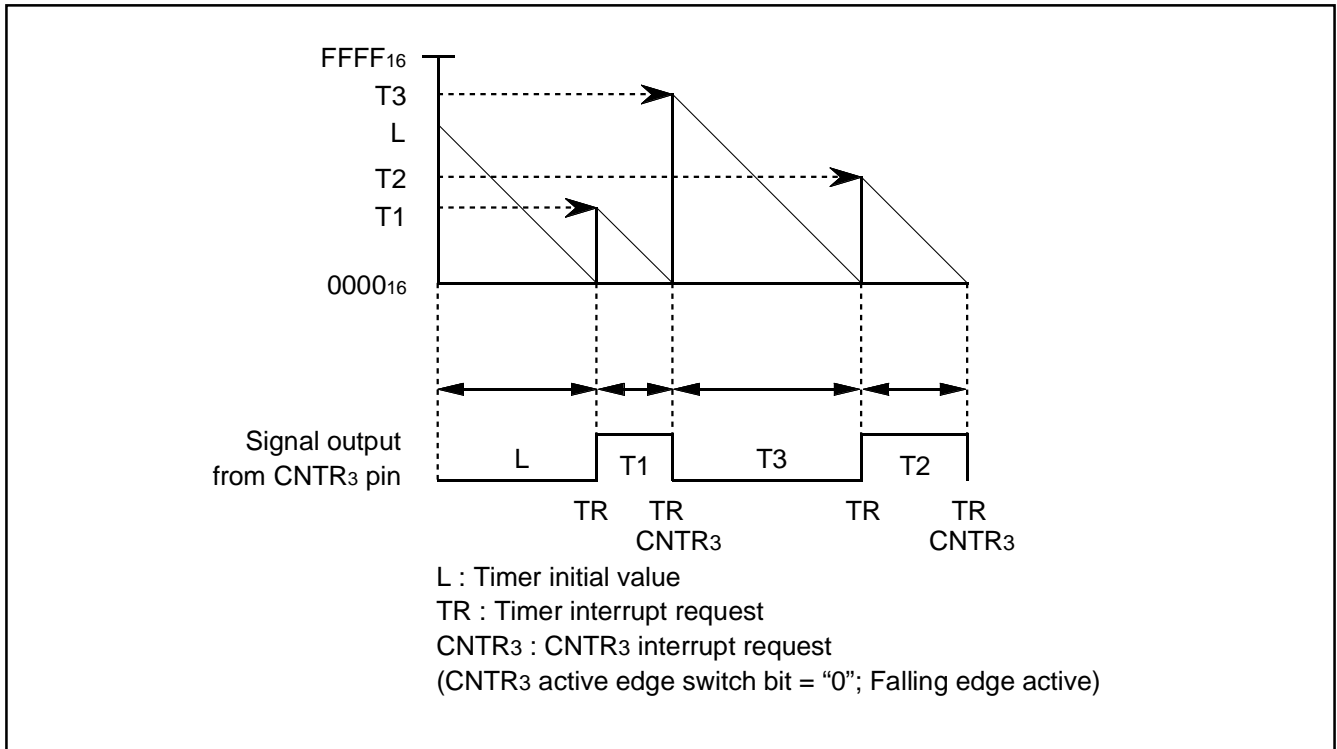

Fig. 34 Timing chart of programmable waveform generating mode

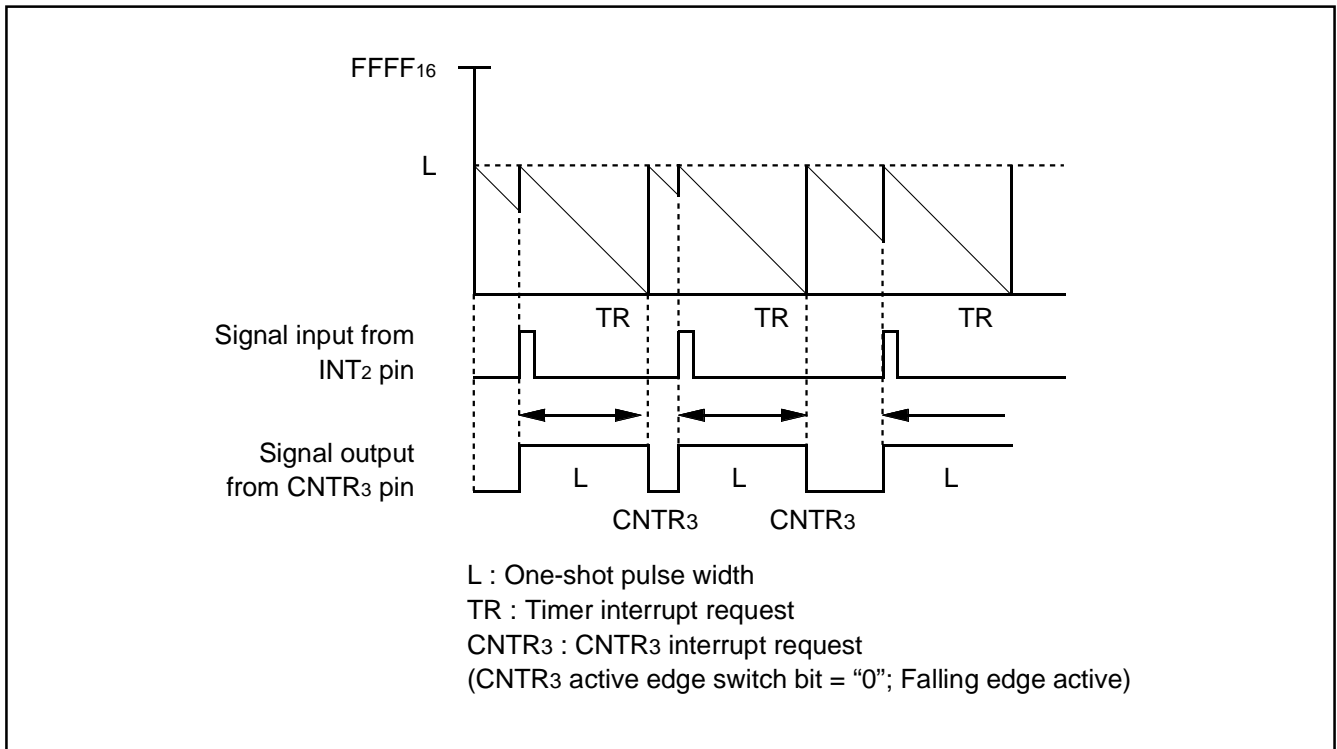

Fig. 35 Timing chart of programmable one-shot generating mode ("H" one-shot pulse generating)

**SERIAL INTERFACE**  
**●SERIAL I/O1**

Serial I/O1 can be used as either clock synchronous or asynchronous (UART) serial I/O1. A dedicated timer is also provided for baud rate generation.

**(1) Clock Synchronous Serial I/O Mode**

Clock synchronous serial I/O mode can be selected by setting the serial I/O1 mode selection bit of the serial I/O1 control register (bit 6 of address 001A16) to "1".

For clock synchronous serial I/O, the transmitter and the receiver must use the same clock. If an internal clock is used, transfer is started by a write signal to the TB/RB.

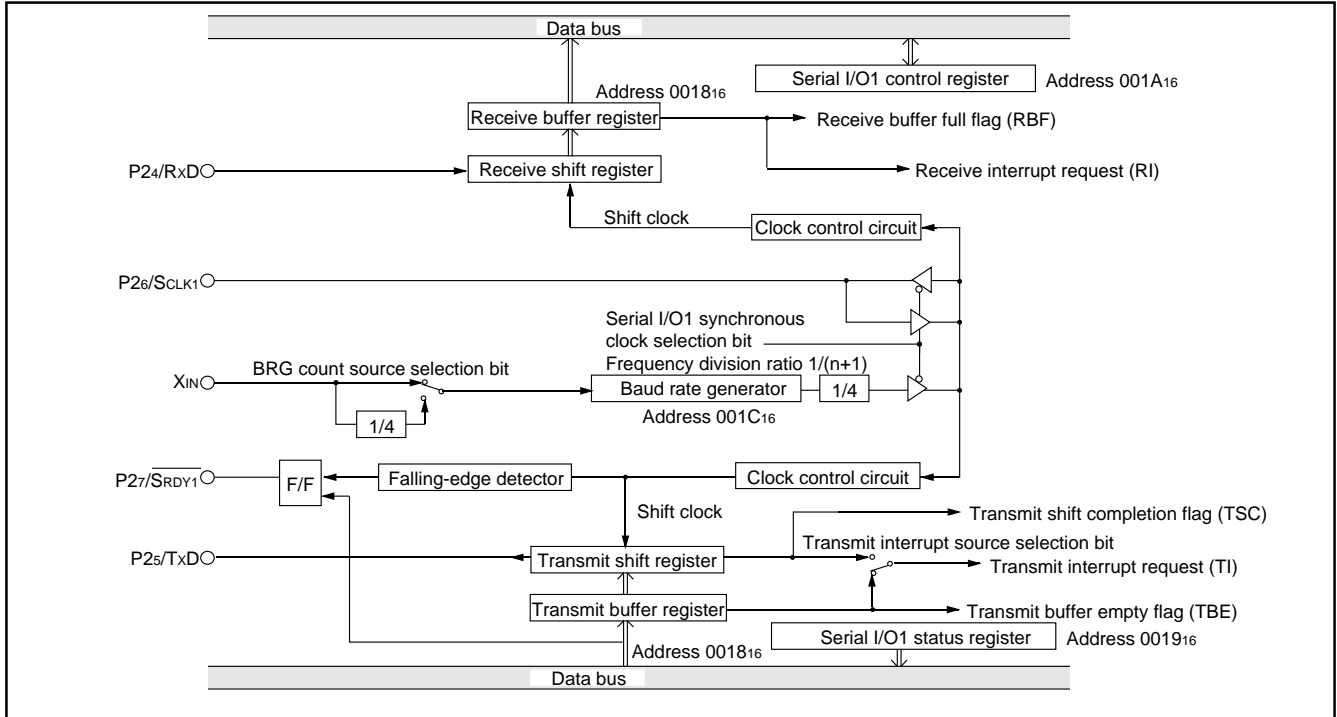

Fig. 36 Block diagram of clock synchronous serial I/O1

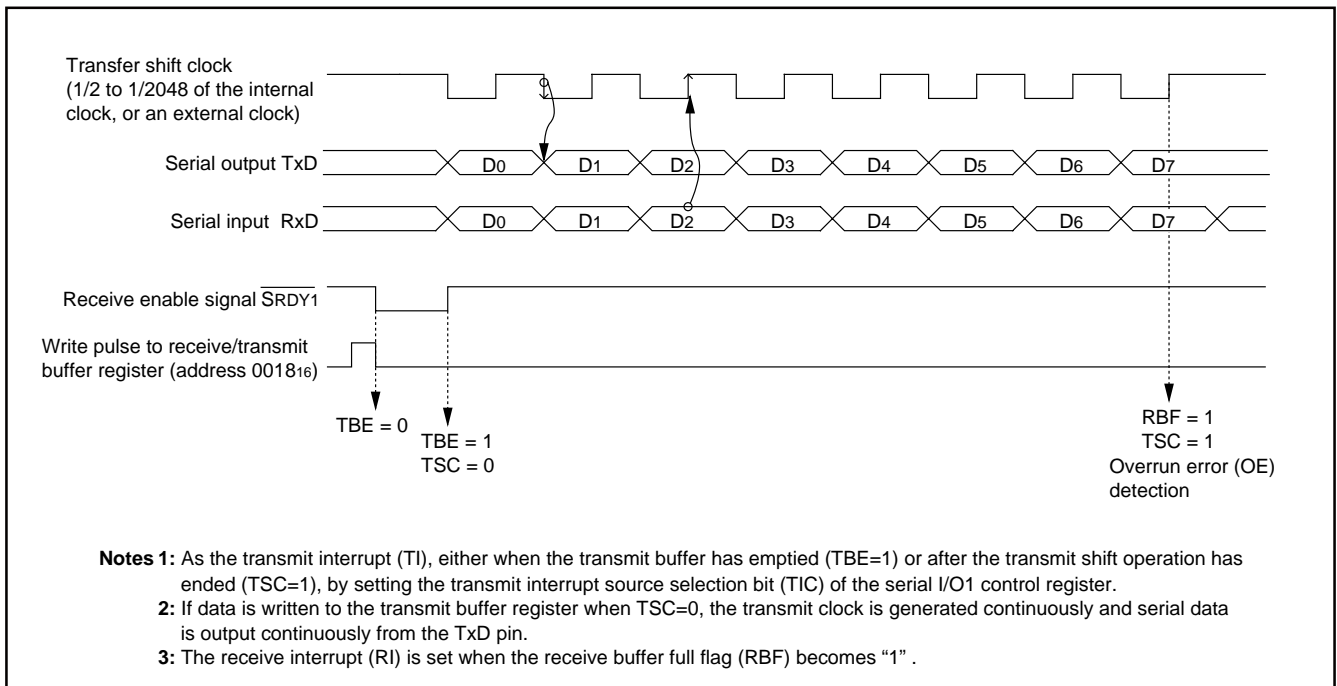

Fig. 37 Operation of clock synchronous serial I/O1 function

## (2) Asynchronous Serial I/O (UART) Mode

Clock asynchronous serial I/O mode (UART) can be selected by clearing the serial I/O1 mode selection bit (b6) of the serial I/O1 control register to "0".

Eight serial data transfer formats can be selected, and the transfer formats used by a transmitter and receiver must be identical.

The transmit and receive shift registers each have a buffer, but the

two buffers have the same address in memory. Since the shift register cannot be written to or read from directly, transmit data is written to the transmit buffer register, and receive data is read from the receive buffer register.

The transmit buffer register can also hold the next data to be transmitted, and the receive buffer register can hold a character while the next character is being received.

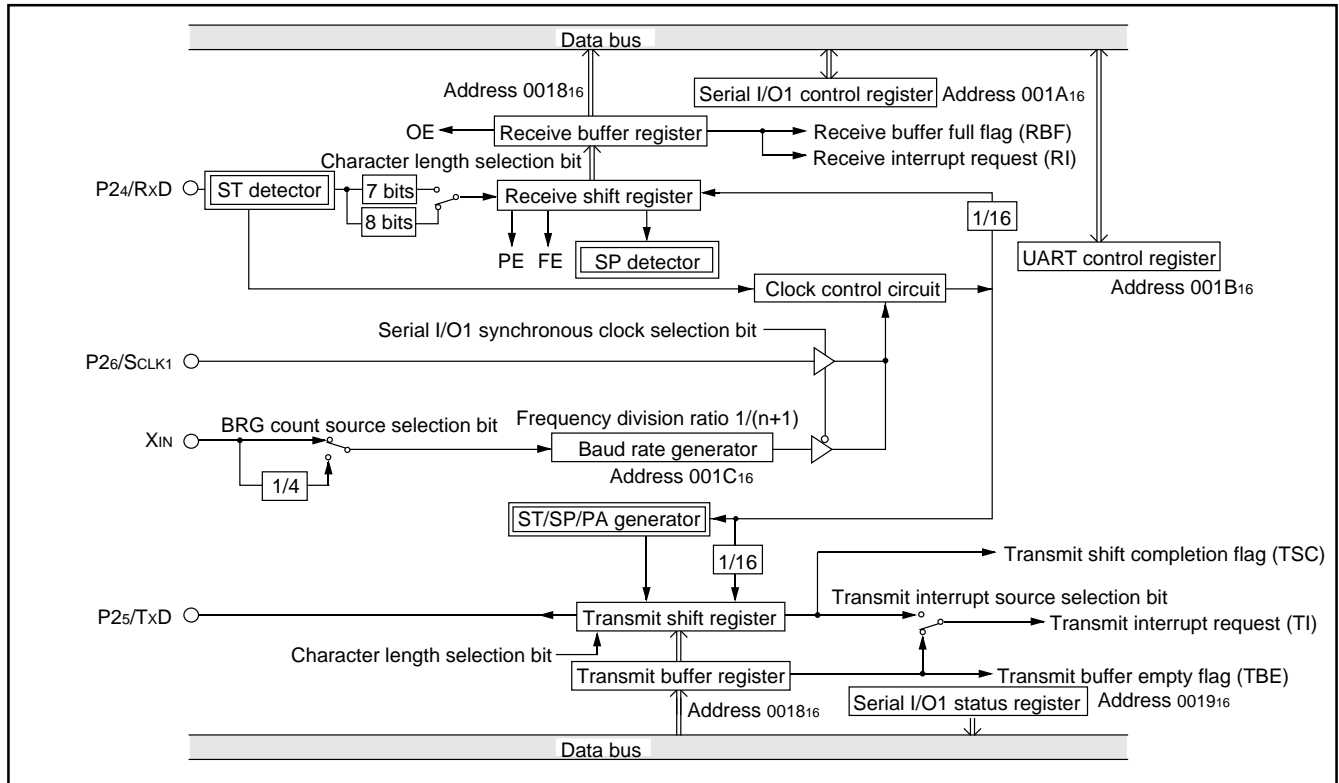

Fig. 38 Block diagram of UART serial I/O1

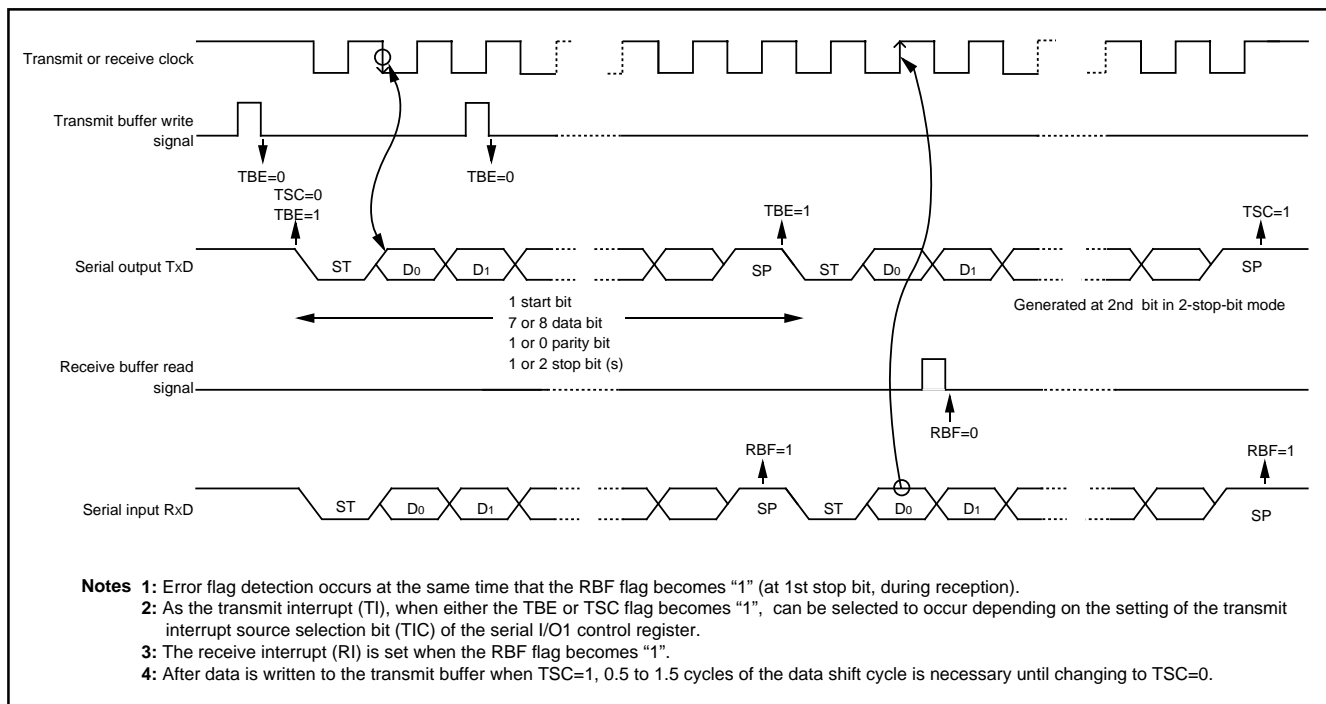

Fig. 39 Operation of UART serial I/O1 function

### [Transmit Buffer Register/Receive Buffer Register (TB/RB)] 001816

The transmit buffer register and the receive buffer register are located at the same address. The transmit buffer is write-only and the receive buffer is read-only. If a character bit length is 7 bits, the MSB of data stored in the receive buffer is "0".

### [Serial I/O1 Status Register (SIOSTS)] 001916

The read-only serial I/O1 status register consists of seven flags (bits 0 to 6) which indicate the operating status of the serial I/O1 function and various errors.

Three of the flags (bits 4 to 6) are valid only in UART mode.

The receive buffer full flag (bit 1) is cleared to "0" when the receive buffer register is read.

If there is an error, it is detected at the same time that data is transferred from the receive shift register to the receive buffer register, and the receive buffer full flag is set. A write to the serial I/O1 status register clears all the error flags OE, PE, FE, and SE (bit 3 to bit 6, respectively). Writing "0" to the serial I/O1 enable bit SIOE (bit 7 of the serial I/O1 control register) also clears all the status flags, including the error flags.

Bits 0 to 6 of the serial I/O1 status register are initialized to "0" at reset, but if the transmit enable bit (bit 4) of the serial I/O1 control register has been set to "1", the transmit shift completion flag (bit 2) and the transmit buffer empty flag (bit 0) become "1".

### [Serial I/O1 Control Register (SIOCON)] 001A16

The serial I/O1 control register consists of eight control bits for the serial I/O1 function.

### [UART Control Register (UARTCON)] 001B16

The UART control register consists of four control bits (bits 0 to 3) which are valid when asynchronous serial I/O is selected and set the data format of an data transfer and one bit (bit 4) which is always valid and sets the output structure of the P25/TxD pin.

### [Baud Rate Generator (BRG)] 001C16

The baud rate generator determines the baud rate for serial transfer.

The baud rate generator divides the frequency of the count source by  $1/(n + 1)$ , where n is the value written to the baud rate generator.

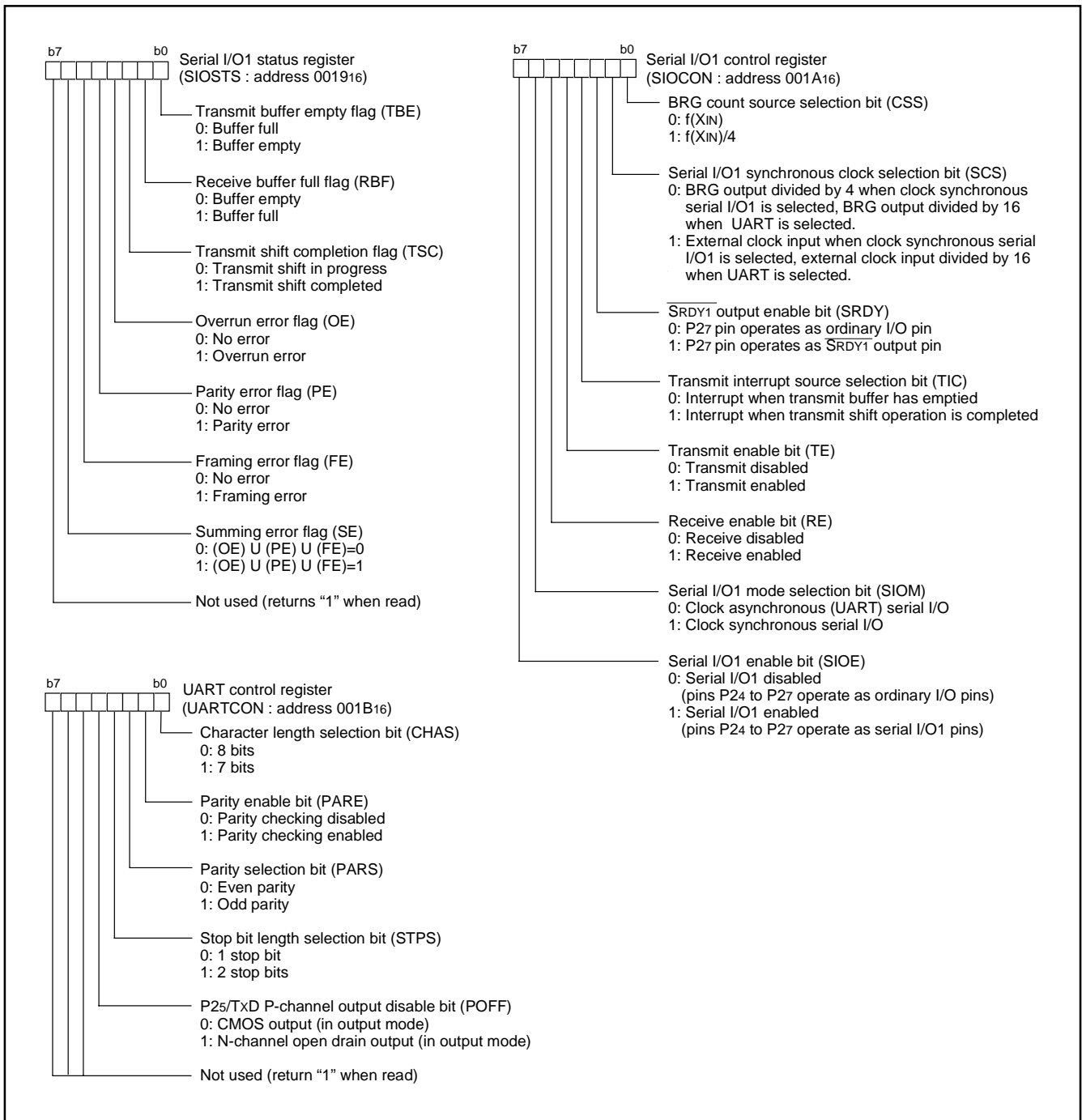

Fig. 40 Structure of serial I/O1 control registers

### ■Notes on serial interface

When setting the transmit enable bit of serial I/O1 to "1", the serial I/O1 transmit interrupt request bit is automatically set to "1". When not requiring the interrupt occurrence synchronized with the transmission enabled, take the following sequence.

- (1) Set the serial I/O1 transmit interrupt enable bit to "0" (disabled).
- (2) Set the transmit enable bit to "1".
- (3) Set the serial I/O1 transmit interrupt request bit to "0" after 1 or more instructions have been executed.
- (4) Set the serial I/O1 transmit interrupt enable bit to "1" (enabled).

## ●SERIAL I/O2

The serial I/O2 can be operated only as the clock synchronous type. As a synchronous clock for serial transfer, either internal clock or external clock can be selected by the serial I/O2 synchronous clock selection bit (b6) of serial I/O2 control register 1.

The internal clock incorporates a dedicated divider and permits selecting 6 types of clock by the internal synchronous clock selection bits (b2, b1, b0) of serial I/O2 control register 1.

Regarding SOUT2 and SCLK2 being output pins, either CMOS output format or N-channel open-drain output format can be selected by the P01/SOUT2, P02/SCLK2 P-channel output disable bit (b7) of serial I/O2 control register 1.

When the internal clock has been selected, a transfer starts by a write signal to the serial I/O2 register (address 001716). After completion of data transfer, the level of the SOUT2 pin goes to high impedance automatically but bit 7 of the serial I/O2 control register 2 is not set to "1" automatically.

When the external clock has been selected, the contents of the serial I/O2 register is continuously sifted while transfer clocks are input. Accordingly, control the clock externally. Note that the SOUT2 pin does not go to high impedance after completion of data transfer.

To cause the SOUT2 pin to go to high impedance in the case where the external clock is selected, set bit 7 of the serial I/O2 control register 2 to "1" when SCLK2 is "H" after completion of data transfer. After the next data transfer is started (the transfer clock falls), bit 7 of the serial I/O2 control register 2 is set to "0" and the SOUT2 pin is put into the active state.

Regardless of the internal clock to external clock, the interrupt request bit is set after the number of bits (1 to 8 bits) selected by the optional transfer bit is transferred. In case of a fractional number of bits less than 8 bits as the last data, the received data to be stored in the serial I/O2 register becomes a fractional number of bits close to MSB if the transfer direction selection bit of serial I/O2 control register 1 is LSB first, or a fractional number of bits close to LSB if the transfer direction selection bit is MSB first. For the remaining bits, the previously received data is shifted.

At transmit operation using the clock synchronous serial I/O, the SCMP2 signal can be output by comparing the state of the transmit pin SOUT2 with the state of the receive pin SIN2 in synchronization with a rise of the transfer clock. If the output level of the SOUT2 pin is equal to the input level to the SIN2 pin, "L" is output from the SCMP2 pin. If not, "H" is output. At this time, an INT2 interrupt request can also be generated. Select a valid edge by bit 2 of the interrupt edge selection register (address 003A16).

### [Serial I/O2 Control Registers 1, 2 (SIO2CON1 / SIO2CON2)] 001516, 001616

The serial I/O2 control registers 1 and 2 are containing various selection bits for serial I/O2 control as shown in Figure 41.

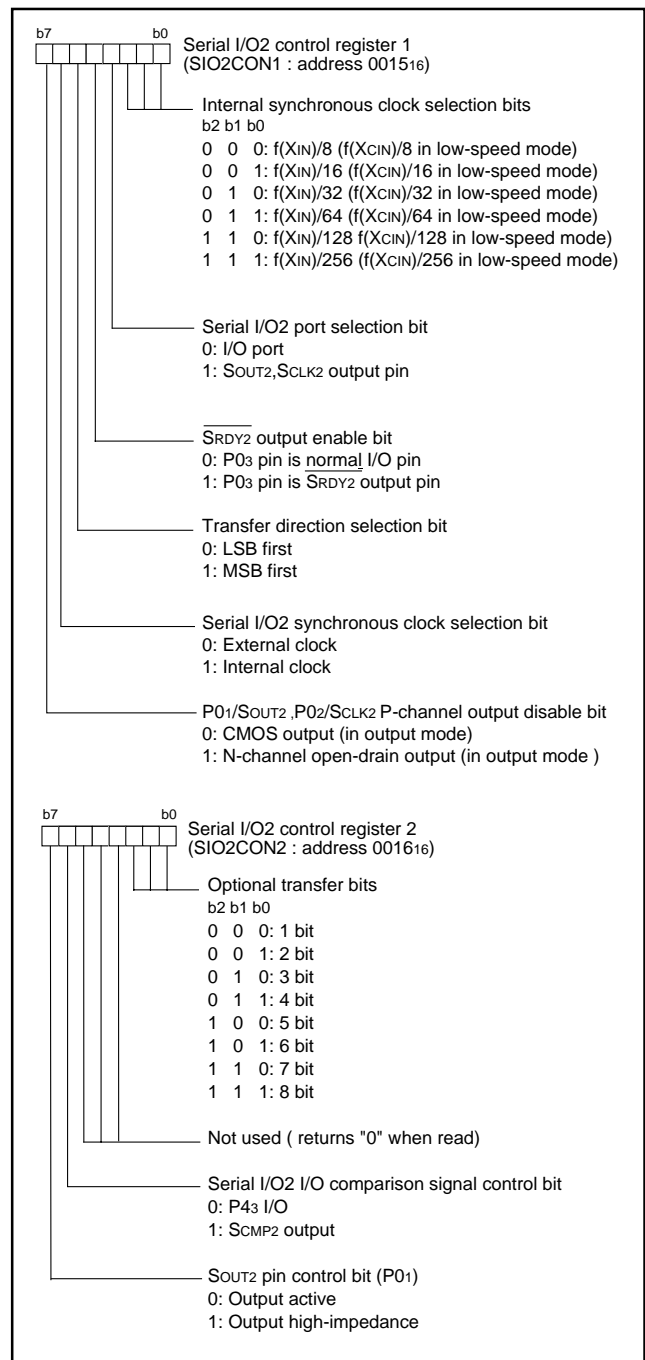

Fig. 41 Structure of Serial I/O2 control registers 1, 2

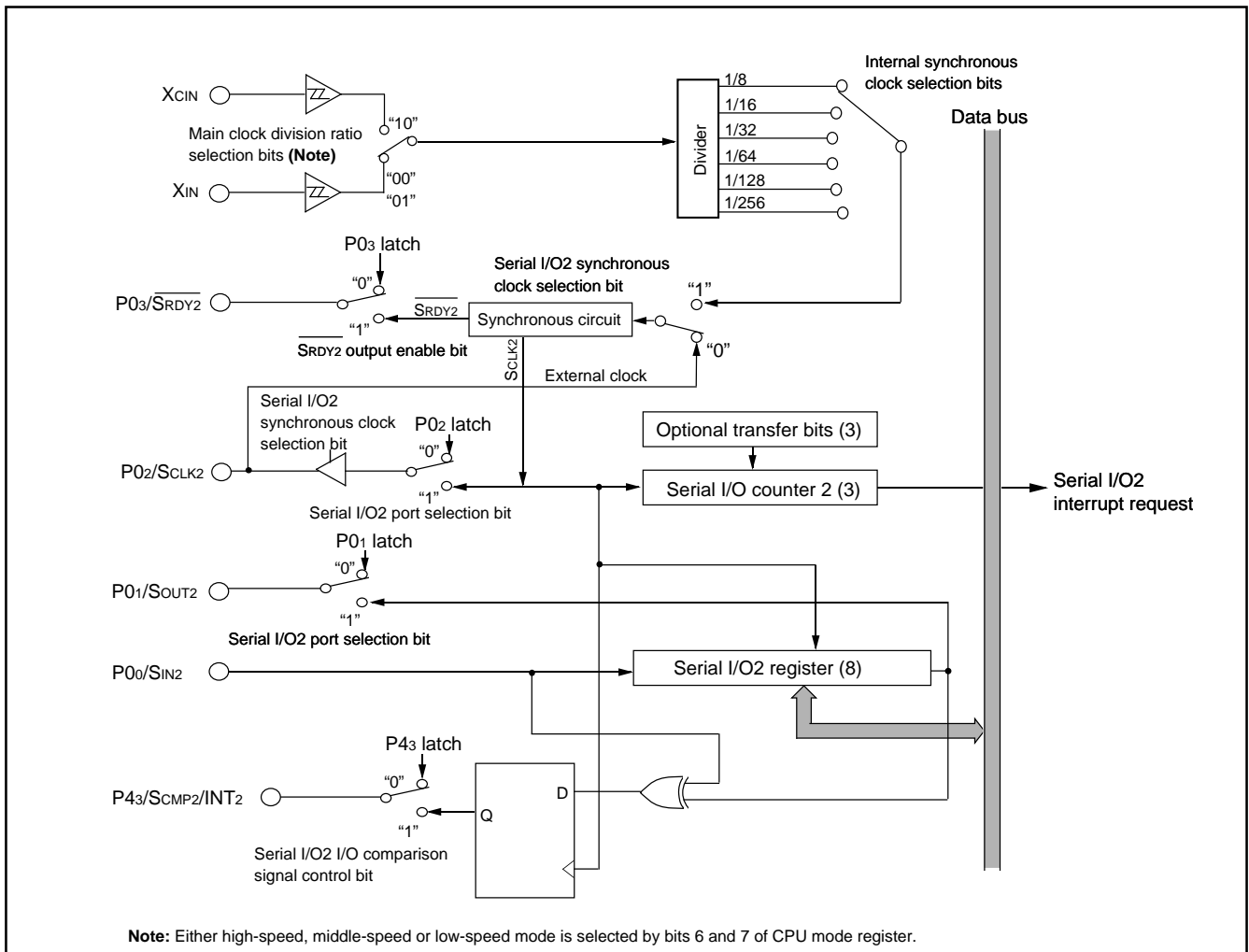

Fig. 42 Block diagram of Serial I/O2

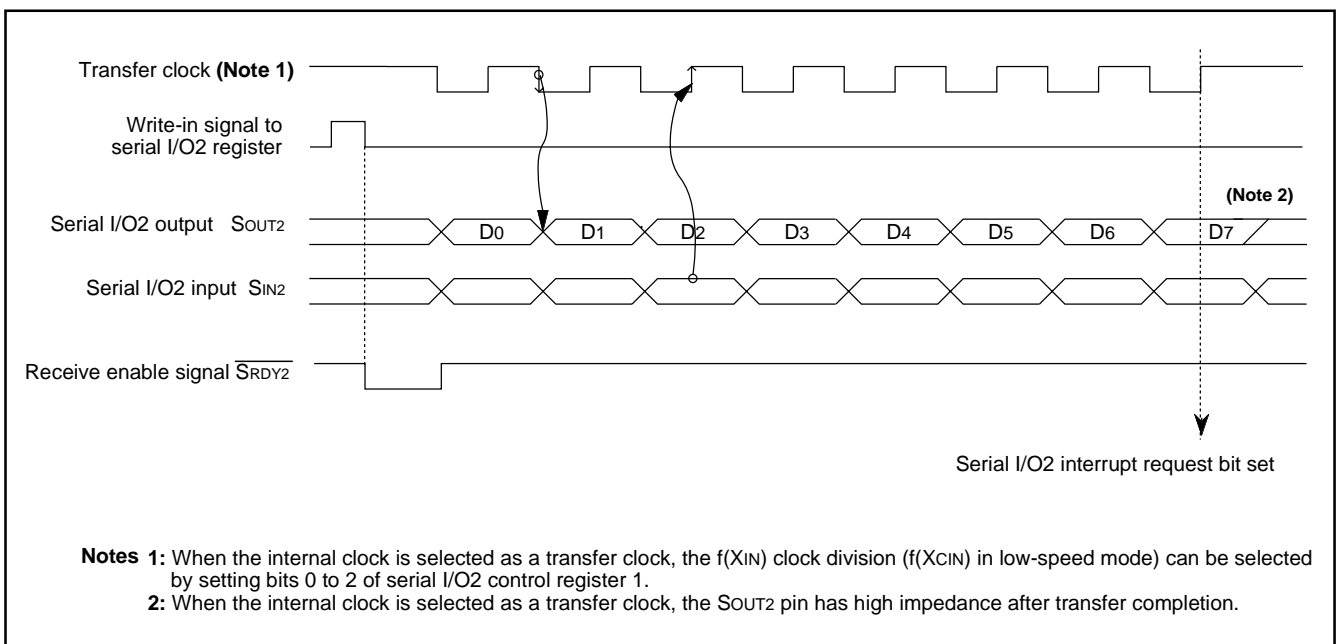

Fig. 43 Timing chart of Serial I/O2



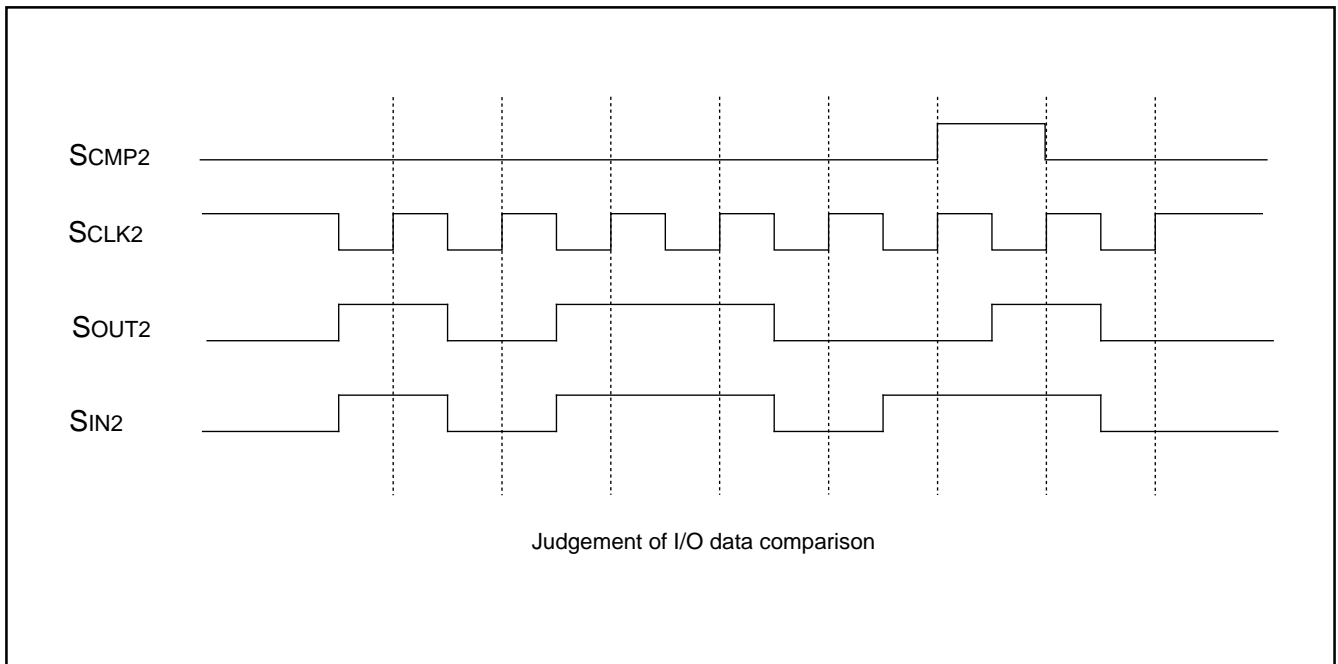

Fig. 44 SCMP2 output operation

### PWM (PWM: Pulse Width Modulation)

The 3858 group has a PWM function with an 8-bit resolution, based on a signal that is the clock input X<sub>IN</sub> or that clock input divided by 2.

### Data Setting

The PWM output pin also functions as port P44. Set the PWM period by the PWM prescaler, and set the "H" term of output pulse by the PWM register.

If the value in the PWM prescaler is n and the value in the PWM register is m (where n = 0 to 255 and m = 0 to 255):

$$\text{PWM period} = 255 \times (n+1) / f(\text{X}_{\text{IN}})$$

$$= 31.875 \times (n+1) \mu\text{s}$$

(when f(X<sub>IN</sub>) = 8 MHz, count source selection bit = "0")

Output pulse "H" term = PWM period × m / 255

$$= 0.125 \times (n+1) \times m \mu\text{s}$$

(when f(X<sub>IN</sub>) = 8 MHz, count source selection bit = "0")

### PWM Operation

When bit 0 (PWM enable bit) of the PWM control register is set to "1", operation starts by initializing the PWM output circuit, and pulses are output starting at an "H".

If the PWM register or PWM prescaler is updated during PWM output, the pulses will change in the cycle after the one in which the change was made.

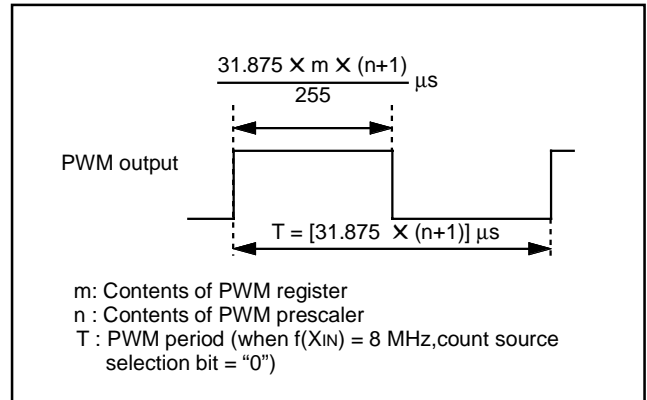

Fig. 45 Timing of PWM period

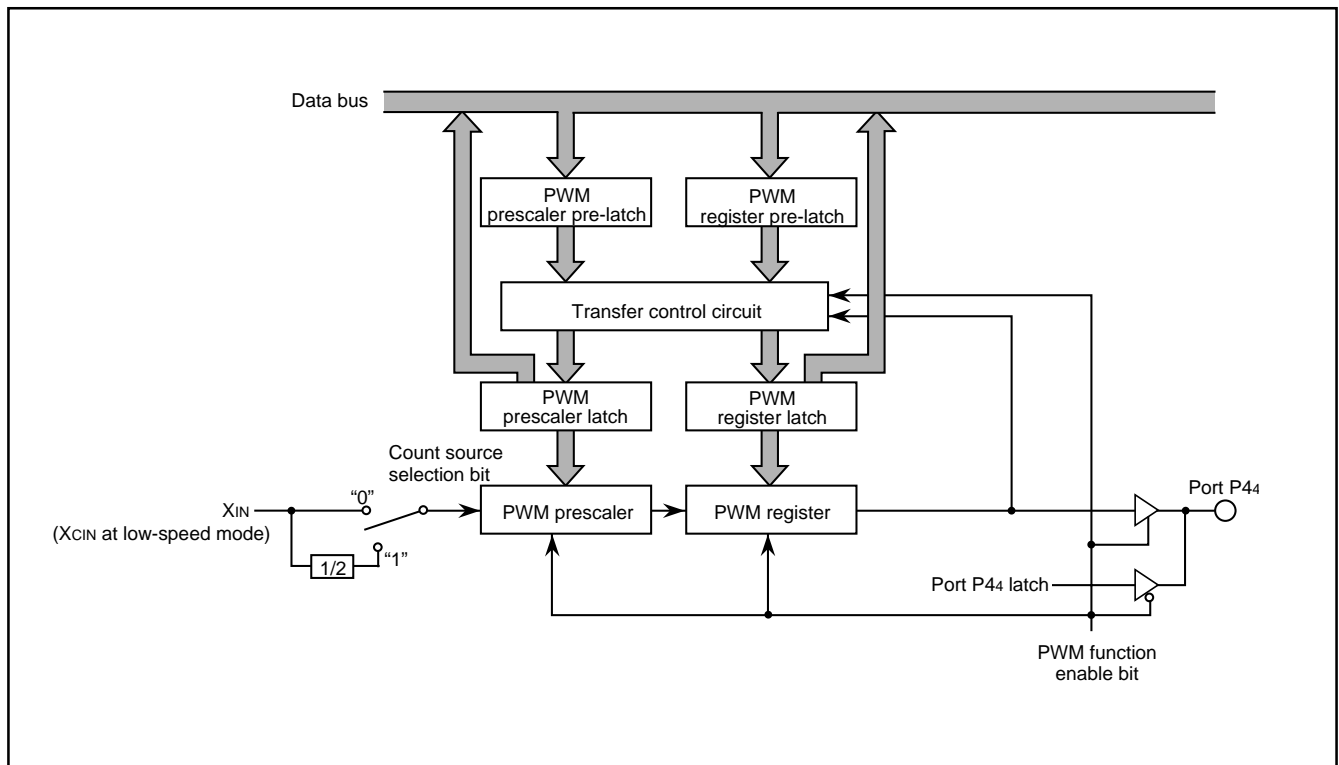

Fig. 46 Block diagram of PWM function

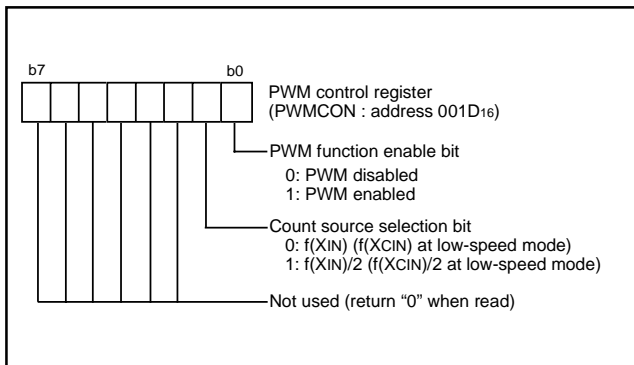

Fig. 47 Structure of PWM control register

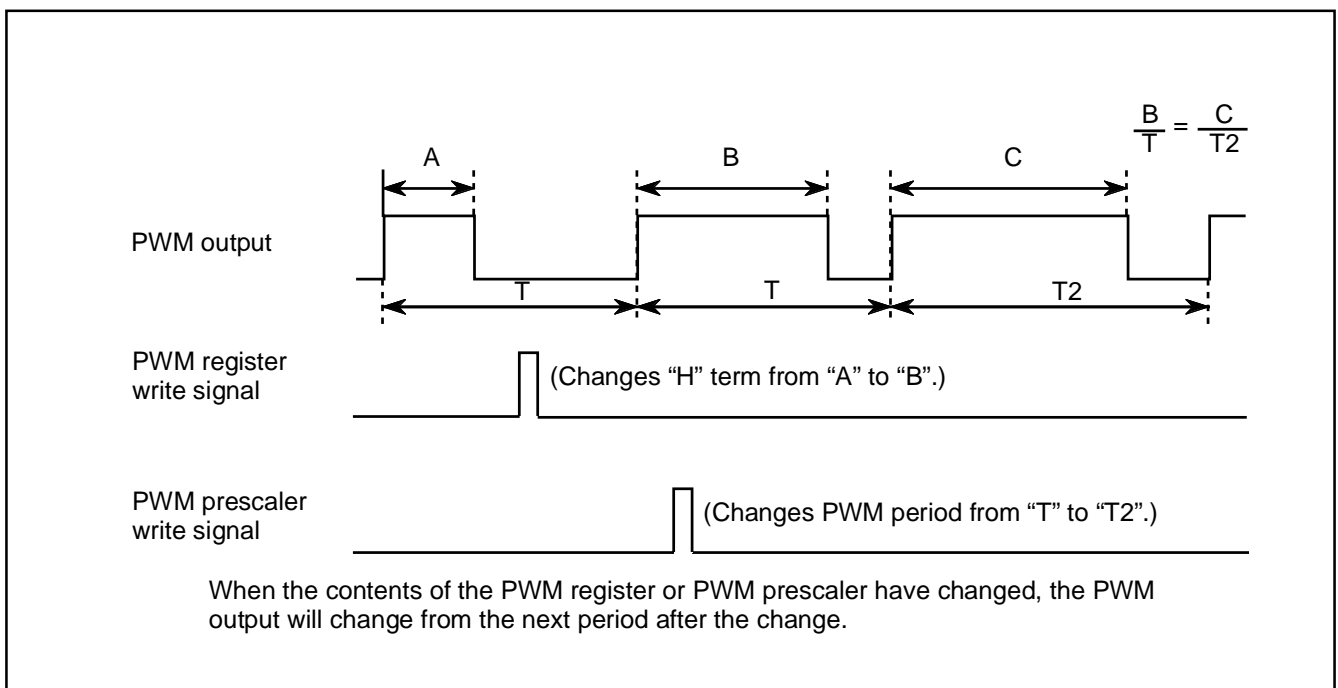

Fig. 48 PWM output timing when PWM register or PWM prescaler is changed

### ■Note

The PWM starts after the PWM function enable bit is set to enable and "L" level is output from the PWM pin. The length of this "L" level output is as follows:

$$\frac{n+1}{2 \times f(X_{IN})} \text{ sec} \quad (\text{Count source selection bit} = 0, \text{ where } n \text{ is the value set in the prescaler})$$

$$\frac{n+1}{f(X_{IN})} \text{ sec} \quad (\text{Count source selection bit} = 1, \text{ where } n \text{ is the value set in the prescaler})$$

### A/D CONVERTER

#### [AD Conversion Register (ADL)] 003516

The A/D conversion register is a read-only register that stores the result of A/D conversion. Do not read out this register during an A/D conversion.

#### [AD Control Register (ADCON)] 003416

The A/D control register controls the A/D converter. Bit 3 to 0 are analog input pin selection bits. Bit 4 is the AD conversion completion bit. The value of this bit remains at "0" during A/D conversion, and changes to "1" at completion of A/D conversion. A/D conversion is started by setting this bit to "0".

#### Comparison Voltage Generator

The comparison voltage generator divides the voltage between AVSS and VREF by 256, and outputs the divided voltages.

#### Channel Selector

The channel selector selects one of ports P30/AN0 to P34/AN4, P04/AN5 to P07/AN8 and inputs the voltage to the comparator.

#### Comparator and Control Circuit

The comparator and control circuit compare an analog input voltage with the comparison voltage, and the result is stored in the AD conversion registers. When an A/D conversion is completed, the control circuit sets the AD conversion completion bit and the AD interrupt request bit to "1".

Note that because the comparator consists of a capacitor coupling, set f(XIN) to 500 kHz or more during an A/D conversion.

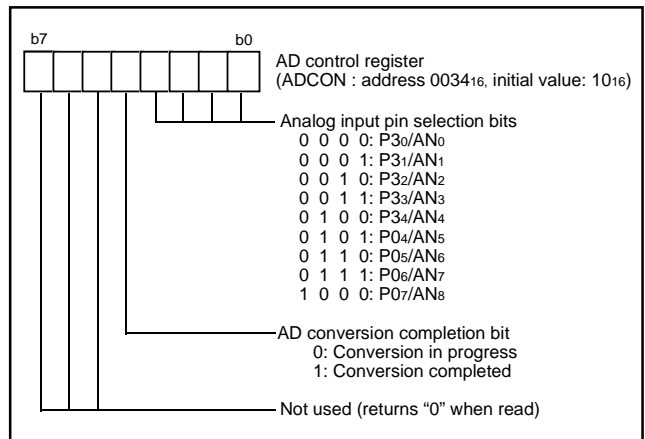

Fig. 49 Structure of AD control register

#### ■Note on A/D converter

The comparator uses internal capacitors whose charge will be lost if the clock frequency is too low.

Make sure that f(XIN) is 500 kHz or more during A/D conversion. As for AD translation accuracy, on the following operating conditions, accuracy may become low.

- (1) Since the analog circuit inside a microcomputer becomes sensitive to noise when VREF voltage is set up lower than Vcc voltage, accuracy may become low rather than the case where VREF voltage and Vcc voltage are set up to the same value..
- (2) When VREF voltage is lower than [ 3.0 V ], the accuracy at the low temperature may become extremely low compared with that at room temperature. When the system would be used at low temperature, the use at VREF=3.0 V or more is recommended.

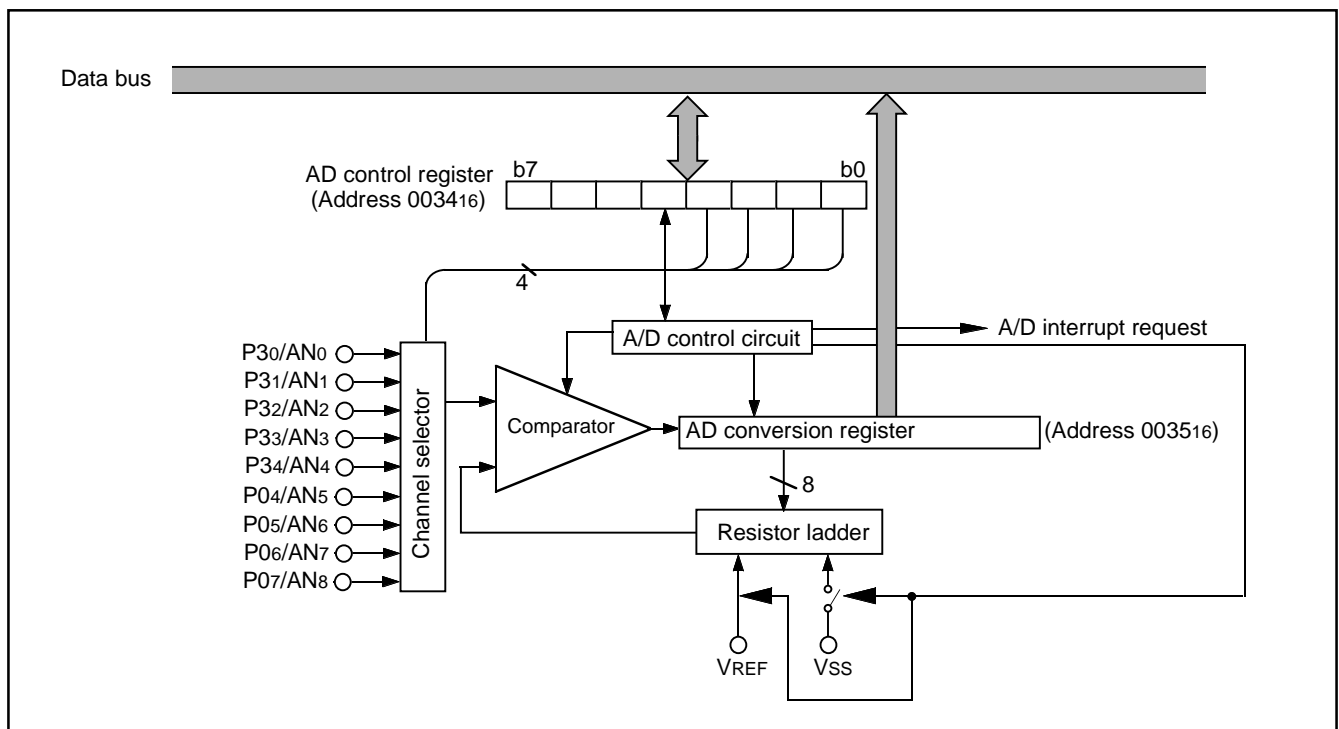

Fig. 50 Block diagram of A/D converter

### WATCHDOG TIMER

The watchdog timer gives a mean of returning to the reset status when a program cannot run on a normal loop (for example, because of a software run-away). The watchdog timer consists of an 8-bit watchdog timer L and an 8-bit watchdog timer H.

#### Initial Value of Watchdog Timer

At reset or writing to the watchdog timer control register (address 0039<sub>16</sub>), each of watchdog timer H and L is set to "FF<sub>16</sub>". Any instruction which generates a write signal such as the instructions of STA, LDM, CLB and others can be used to write. The data of bits 6 and 7 are only valid when writing to the watchdog timer control register. Each of watchdog timer is set to "FF<sub>16</sub>" regardless of the written data of bits 0 to 5.

Bit 6 can be written to only once after reset release. After this bit is written, it cannot be rewritten because it is locked.

#### Operation of Watchdog Timer

The watchdog timer stops at reset and starts to count down by writing to the watchdog timer control register. An internal reset occurs at an underflow of the watchdog timer H. The reset is released after waiting for a reset release time and the program is processed from the reset vector address. Accordingly, programming is usually performed so that writing to the watchdog timer control register may be started before an underflow of the watch-

dog timer H. If writing to the watchdog timer control register is not performed once, the watchdog timer does not function.

#### Bit 6 of Watchdog Timer Control Register

When bit 6 of the watchdog timer control register is "0", the MCU enters the stop mode by execution of STP instruction. Just after releasing the stop mode, the watchdog timer restarts counting (Note). When executing the WIT instruction, the watchdog timer does not stop.

When bit 6 is "1", execution of STP instruction causes an internal reset. When this bit is set to "1" once, it cannot be rewritten to "0" by program. Bit 6 is "0" at reset.

The necessary time after writing to the watchdog timer control register to an underflow of the watchdog timer H is shown as follows.

When bit 7 of the watchdog timer control register is "0":

32 s at X<sub>CIN</sub> = 32.768 kHz frequency and

131.072 ms at X<sub>IN</sub> = 8 MHz frequency.

When bit 7 of the watchdog timer control register is "1":

125 ms at X<sub>CIN</sub> = 32.768 kHz frequency and

512 μs at X<sub>IN</sub> = 8 MHz frequency.

Note: The watchdog timer continues to count for waiting for a stop mode release time. Do not generate an underflow of the watchdog timer H during that time.

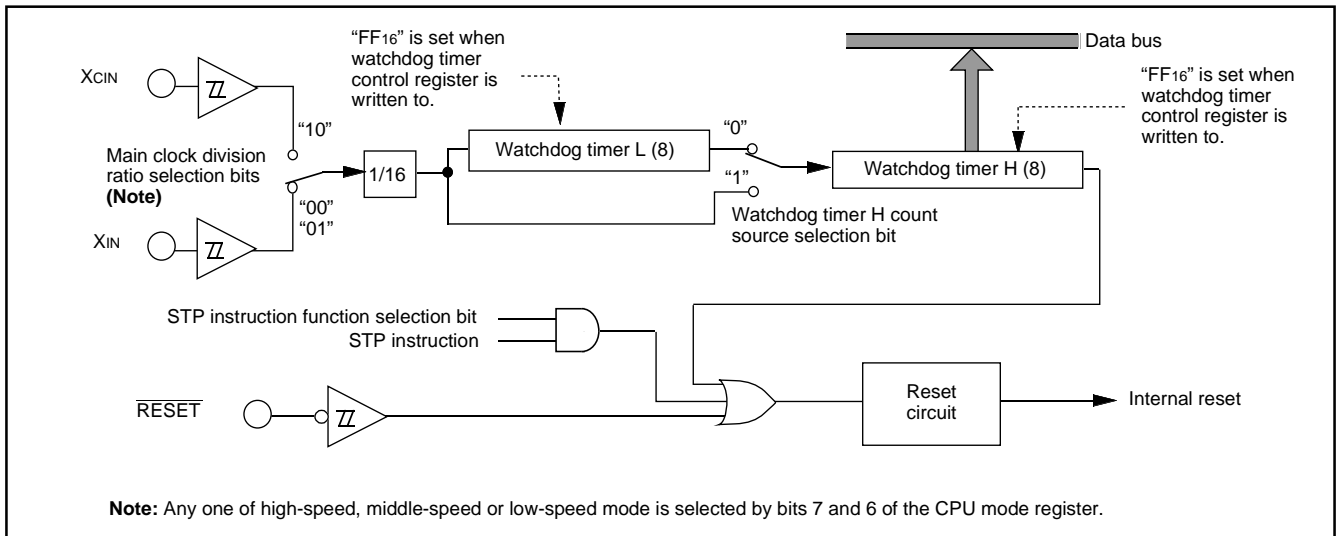

Fig. 51 Block diagram of Watchdog timer

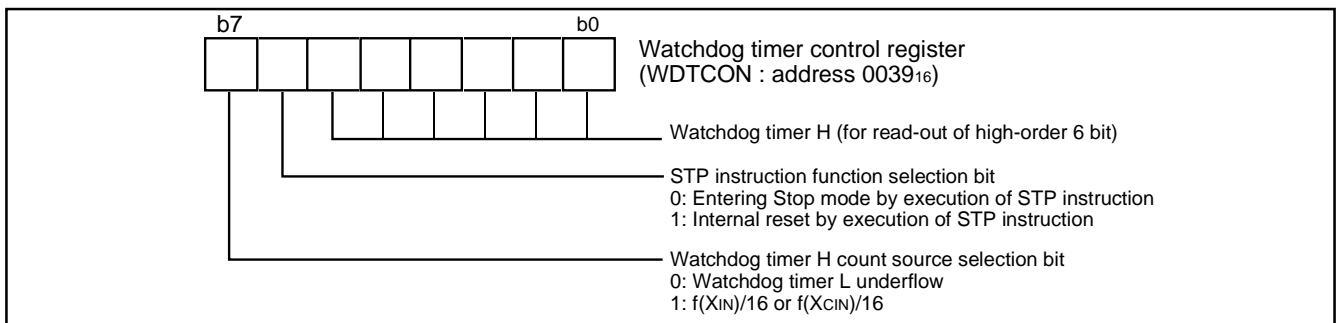

Fig. 52 Structure of Watchdog timer control register

### RESET CIRCUIT

To reset the microcomputer,  $\overline{\text{RESET}}$  pin must be held at an "L" level for 20 cycles or more of  $X_{\text{IN}}$ . Then the  $\overline{\text{RESET}}$  pin is returned to an "H" level (the power source must be between 2.7 V and 5.5 V, and the oscillation must be stable), reset is released. After the reset is completed, the program starts from the address  $\text{FFFD}_{16}$  (high-order byte) and address  $\text{FFFC}_{16}$  (low-order byte). Make sure that the reset input voltage is less than 0.54 V for  $V_{\text{CC}}$  of 2.7 V.

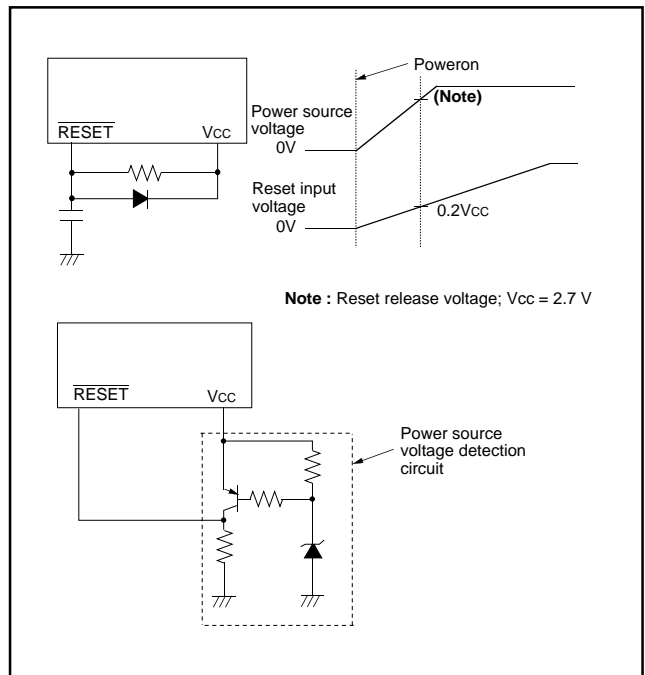

Fig. 53 Reset circuit example

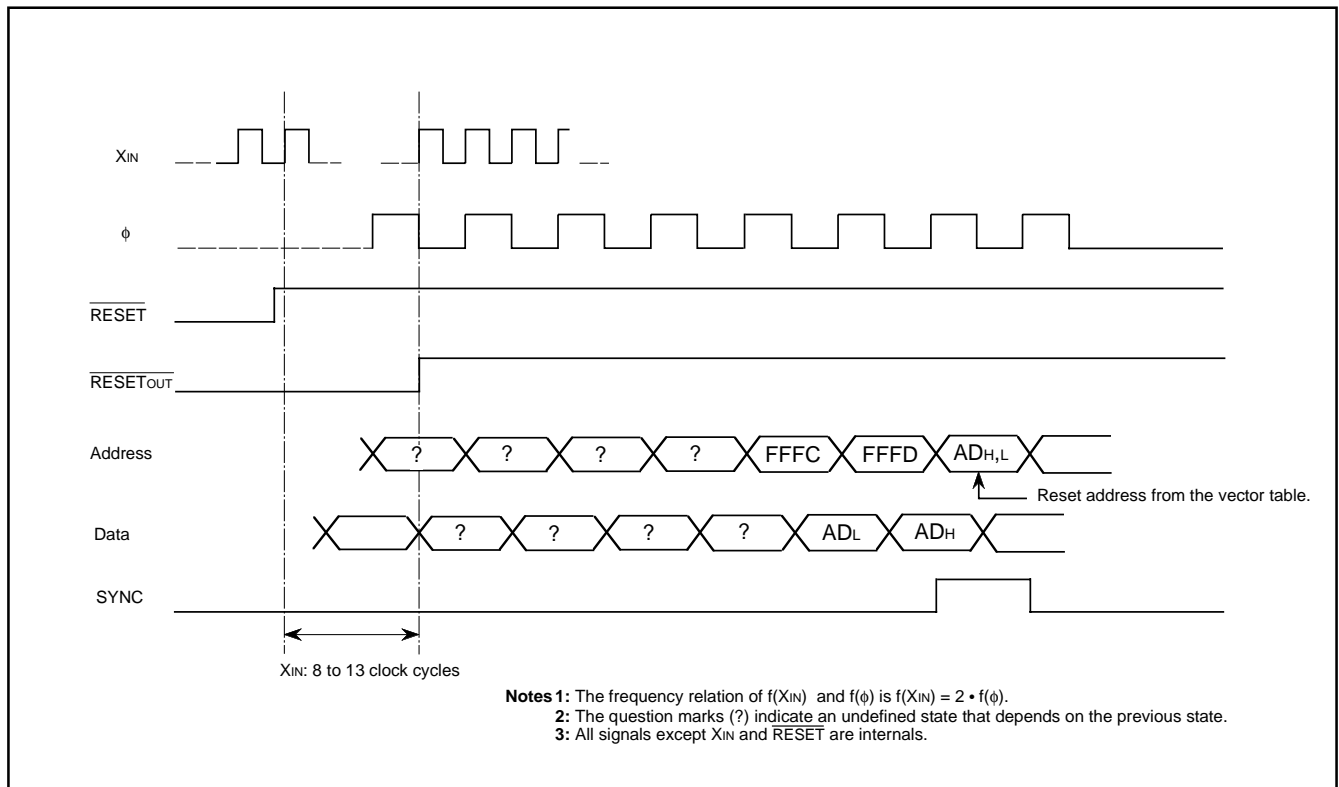

Fig. 54 Reset sequence

	Address	Register contents		Address	Register contents
(1) Port P0 (P0)	0000 <sub>16</sub>	00 <sub>16</sub>	(35) Timer Z1 mode register (TZ1M)	0028 <sub>16</sub>	00 <sub>16</sub>
(2) Port P0 direction register (P0D)	0001 <sub>16</sub>	00 <sub>16</sub>	(36) Timer Z1 low-order (TZ1L)	0029 <sub>16</sub>	FF <sub>16</sub>
(3) Port P1 (P1)	0002 <sub>16</sub>	00 <sub>16</sub>	(37) Timer Z1 high-order (TZ1H)	002A <sub>16</sub>	FF <sub>16</sub>
(4) Port P1 direction register (P1D)	0003 <sub>16</sub>	00 <sub>16</sub>	(38) Timer Z2 mode register (TZ2M)	002B <sub>16</sub>	00 <sub>16</sub>
(5) Port P2 (P2)	0004 <sub>16</sub>	00 <sub>16</sub>	(39) Timer Z2 low-order (TZ2L)	002C <sub>16</sub>	FF <sub>16</sub>
(6) Port P2 direction register (P2D)	0005 <sub>16</sub>	00 <sub>16</sub>	(40) Timer Z2 high-order (TZ2H)	002D <sub>16</sub>	FF <sub>16</sub>
(7) Port P3 (P3)	0006 <sub>16</sub>	00 <sub>16</sub>	(41) Timer 12, X count source selection register (T12XCSS)	002E <sub>16</sub>	00110011
(8) Port P3 direction register (P3D)	0007 <sub>16</sub>	00 <sub>16</sub>	(42) Timer Y, Z1 count source selection register (TYZ1CSS)	002F <sub>16</sub>	00110011
(9) Port P4 (P4)	0008 <sub>16</sub>	00 <sub>16</sub>	(43) Timer Z2 count source selection register (TZ2CSS)	0030 <sub>16</sub>	00000011
(10) Port P4 direction register (P4D)	0009 <sub>16</sub>	00 <sub>16</sub>	(44) AD control register (ADCON)	0034 <sub>16</sub>	00010000
(11) Port P0 pull-up control register (PULL0)	0010 <sub>16</sub>	00 <sub>16</sub>	(45) AD conversion register (AD)	0035 <sub>16</sub>	XXXXXXXX
(12) Port P1 pull-up control register (PULL1)	0011 <sub>16</sub>	00 <sub>16</sub>	(46) Interrupt source selection register (INTSEL)	0036 <sub>16</sub>	00 <sub>16</sub>
(13) Port P2 pull-up control register (PULL2)	0012 <sub>16</sub>	00 <sub>16</sub>	(47) MISRG	0038 <sub>16</sub>	00 <sub>16</sub>
(14) Port P3 pull-up control register (PULL3)	0013 <sub>16</sub>	00 <sub>16</sub>	(48) Watchdog timer control register (WDTCON)	0039 <sub>16</sub>	00111111
(15) Port P4 pull-up control register (PULL4)	0014 <sub>16</sub>	00 <sub>16</sub>	(49) Interrupt edge selection register (INTEDGE)	003A <sub>16</sub>	00 <sub>16</sub>
(16) Serial I/O2 control register 1 (SIO2CON1)	0015 <sub>16</sub>	00 <sub>16</sub>	(50) CPU mode register (CPUM)	003B <sub>16</sub>	01001000
(17) Serial I/O2 control register 2 (SIO2CON2)	0016 <sub>16</sub>	00000111	(51) Interrupt request register 1 (IREQ1)	003C <sub>16</sub>	00 <sub>16</sub>
(18) Serial I/O2 register (SIO2)	0017 <sub>16</sub>	XXXXXXXX	(52) Interrupt request register 2 (IREQ2)	003D <sub>16</sub>	00 <sub>16</sub>
(19) Transmit/Receive buffer register (TB/RB)	0018 <sub>16</sub>	XXXXXXXX	(53) Interrupt control register 1 (ICON1)	003E <sub>16</sub>	00 <sub>16</sub>
(20) Serial I/O1 status register (SIOSTS)	0019 <sub>16</sub>	10000000	(54) Interrupt control register 2 (ICON2)	003F <sub>16</sub>	00 <sub>16</sub>
(21) Serial I/O1 control register (SIOCON)	001A <sub>16</sub>	00 <sub>16</sub>	Processor status register (PS)		XXXXXXXX1X
(22) UART control register (UARTCON)	001B <sub>16</sub>	11100000	Program counter (PC <sub>H</sub> )		FFF <sub>16</sub> contents
(23) Baud rate generator (BRG)	001C <sub>16</sub>	XXXXXXXX	(PC <sub>L</sub> )		FFF <sub>16</sub> contents
(24) PWM control register (PWMCON)	001D <sub>16</sub>	00 <sub>16</sub>			
(25) PWM prescaler (PREPWM)	001E <sub>16</sub>	XXXXXXXX			
(26) PWM register (PWM)	001F <sub>16</sub>	XXXXXXXX			
(27) Prescaler 12 (PRE12)	0020 <sub>16</sub>	FF <sub>16</sub>			
(28) Timer 1 (T1)	0021 <sub>16</sub>	01 <sub>16</sub>			
(29) Timer 2 (T2)	0022 <sub>16</sub>	FF <sub>16</sub>			
(30) Timer XY mode register (TM)	0023 <sub>16</sub>	00 <sub>16</sub>			
(31) Prescaler X (PREX)	0024 <sub>16</sub>	FF <sub>16</sub>			
(32) Timer X (TX)	0025 <sub>16</sub>	FF <sub>16</sub>			
(33) Prescaler Y (PREY)	0026 <sub>16</sub>	FF <sub>16</sub>			
(34) Timer Y (TY)	0027 <sub>16</sub>	FF <sub>16</sub>			

**Note :** X : Not fixed  
 Since the initial values for other than above mentioned registers and RAM contents are indefinite at reset, they must be set.

Fig. 55 Internal status at reset

## CLOCK GENERATING CIRCUIT

The 3858 group has two built-in oscillation circuits. An oscillation circuit can be formed by connecting a resonator between X<sub>IN</sub> and X<sub>OUT</sub> (X<sub>CIN</sub> and X<sub>COU</sub>T). Use the circuit constants in accordance with the resonator manufacturer's recommended values. No external resistor is needed between X<sub>IN</sub> and X<sub>OUT</sub> since a feed-back resistor exists on-chip. (An external feed-back resistor may be needed depending on conditions.) However, an external feed-back resistor is needed between X<sub>CIN</sub> and X<sub>COU</sub>T.

Immediately after power on, only the X<sub>IN</sub> oscillation circuit starts oscillating, and X<sub>CIN</sub> and X<sub>COU</sub>T pins function as I/O ports.

### ●Frequency Control

#### (1) Middle-speed mode

The internal clock  $\phi$  is the frequency of X<sub>IN</sub> divided by 8. After reset is released, this mode is selected.

#### (2) High-speed mode

The internal clock  $\phi$  is half the frequency of X<sub>IN</sub>.

#### (3) Low-speed mode

The internal clock  $\phi$  is half the frequency of X<sub>CIN</sub>.

#### (4) Low power dissipation mode

The low power consumption operation can be realized by stopping the main clock X<sub>IN</sub> in low-speed mode. To stop the main clock, set bit 5 of the CPU mode register to "1". When the main clock X<sub>IN</sub> is restarted (by setting the main clock stop bit to "0"), set sufficient time for oscillation to stabilize.

The sub-clock X<sub>CIN</sub>-X<sub>COU</sub>T oscillating circuit can not directly input clocks that are generated externally. Accordingly, make sure to cause an external resonator to oscillate.

### ●Oscillation Control

#### (1) Stop mode

If the STP instruction is executed, the internal clock  $\phi$  stops at an "H" level, and X<sub>IN</sub> and X<sub>CIN</sub> oscillation stops. When the oscillation stabilizing time set after STP instruction released bit (bit 0 of address 003816) is "0", the prescaler 12 is set to "FF16" and timer 1 is set to "0116". When the oscillation stabilizing time set after STP instruction released bit is "1", set the sufficient time for oscillation of used oscillator to stabilize since nothing is set to the prescaler 12 and timer 1.

After STP instruction is released, the input of the prescaler 12 is connected to count source which had set at executing the STP instruction, and the output of the prescaler 12 is connected to timer 1. Oscillator restarts when an external interrupt is received, but the internal clock  $\phi$  is not supplied to the CPU (remains at "H") until timer 1 underflows. The internal clock  $\phi$  is supplied for the first time, when timer 1 underflows. This ensures time for the clock oscillation using the ceramic resonators to be stabilized. When the oscillator is restarted by reset, apply "L" level to the RESET pin until the oscillation is stable since a wait time will not be generated.

## (2) Wait mode

If the WIT instruction is executed, the internal clock  $\phi$  stops at an "H" level, but the oscillator does not stop. The internal clock  $\phi$  restarts at reset or when an interrupt is received. Since the oscillator does not stop, normal operation can be started immediately after the clock is restarted.

To ensure that the interrupts will be received to release the STP or WIT state, their interrupt enable bits must be set to "1" before executing of the STP or WIT instruction.

When releasing the STP state, the input of the prescaler 12 and timer 1 is connected to the count source which had set at executing the STP instruction and the prescaler 12 and timer 1 will start counting. Set the timer 1 interrupt enable bit to "0" before executing the STP instruction.

### ■Notes

- If you switch the mode between middle/high-speed and low-speed, stabilize both X<sub>IN</sub> and X<sub>CIN</sub> oscillations. The sufficient time is required for the sub-clock to stabilize, especially immediately after power on and at returning from the stop mode. When switching the mode between middle/high-speed and low-speed, set the frequency on condition that  $f(X_{IN}) > 3 \times f(X_{CIN})$ .
- When using the oscillation stabilizing time set after STP instruction released bit set to "1", evaluate time to stabilize oscillation of the used oscillator and set the value to the timer 1 and prescaler 12.

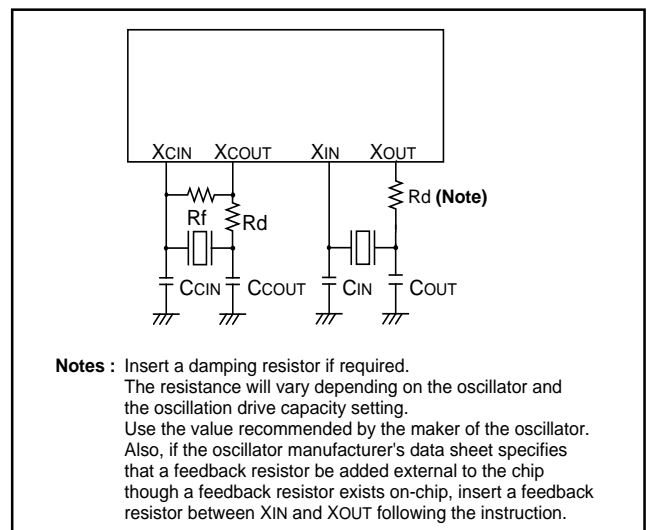

Fig. 56 Ceramic resonator circuit

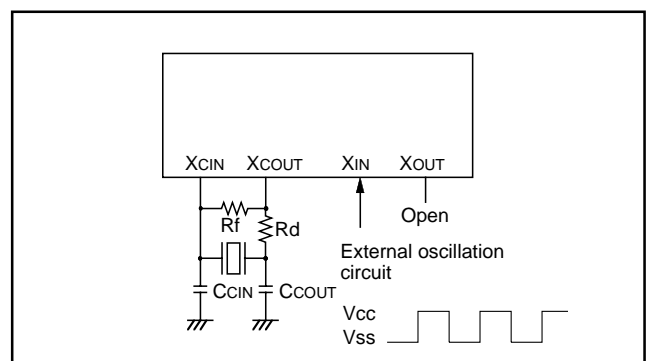

Fig. 57 External clock input circuit



**[MISRG (MISRG)] 003816**

MISRG consists of three control bits (bits 1 to 3) for middle-speed mode automatic switch and one control bit (bit 0) for oscillation stabilizing time set after STP instruction released.

By setting the middle-speed mode automatic switch start bit to "1" while operating in the low-speed mode and setting the middle-speed mode automatic switch set bit to "1", XIN oscillation automatically starts and the mode is automatically switched to the middle-speed mode.

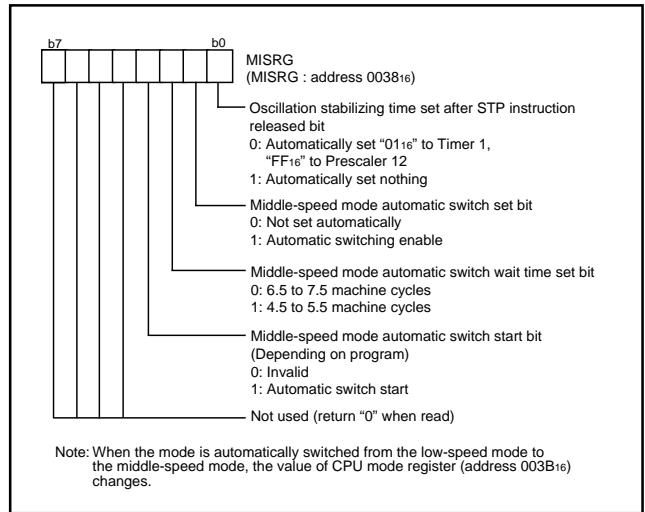

Fig. 58 Structure of MISRG

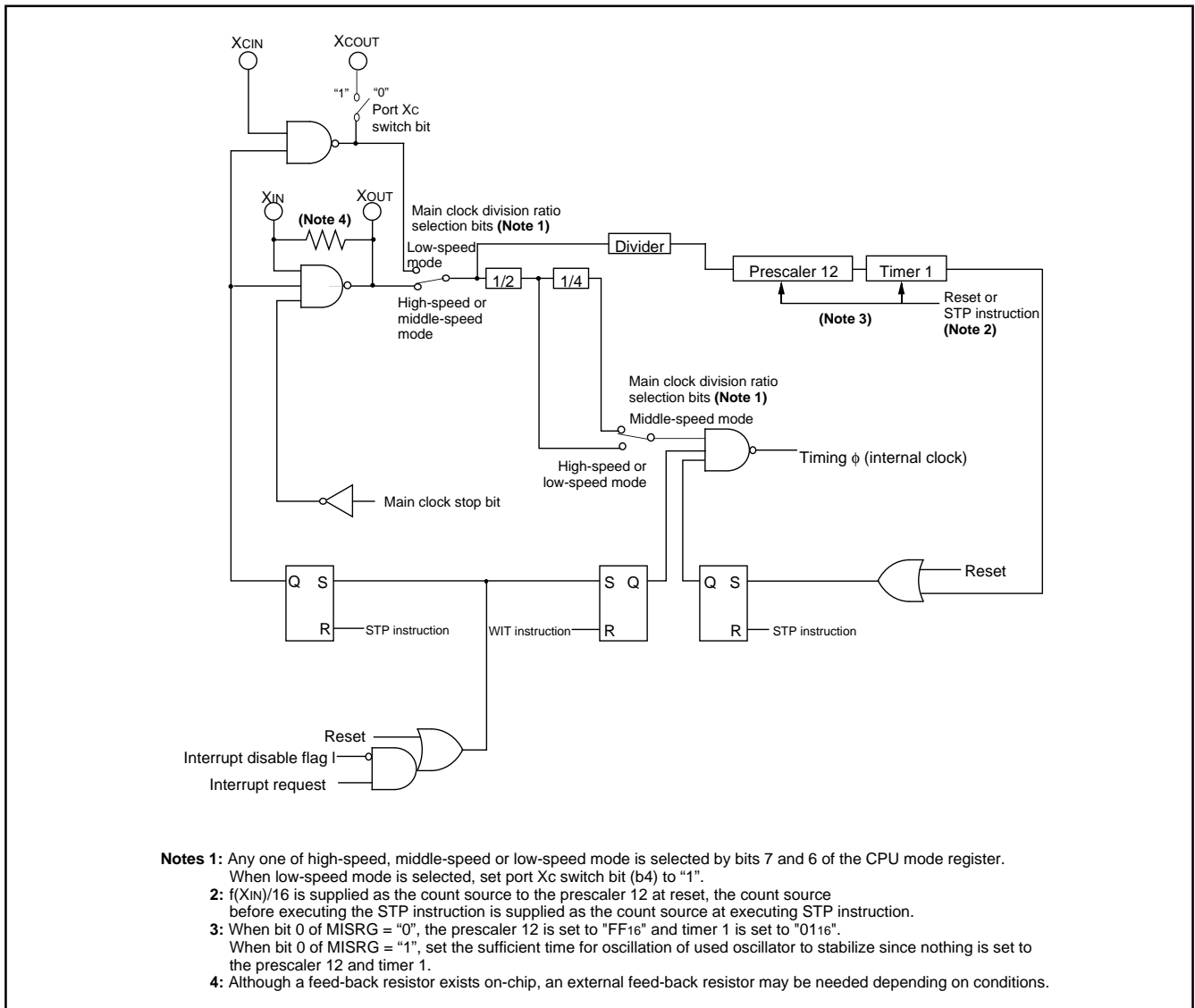
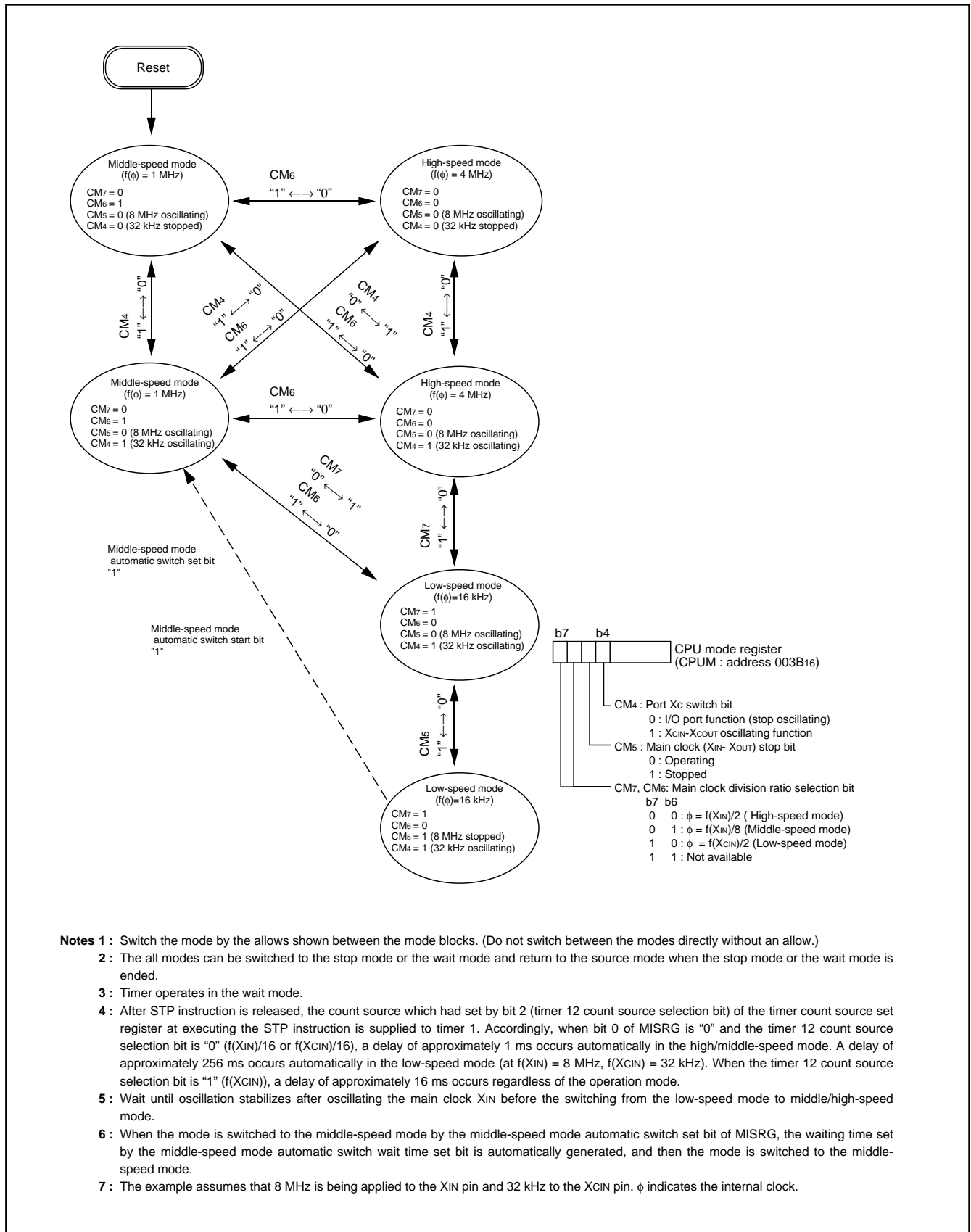

Fig. 59 System clock generating circuit block diagram (Single-chip mode)



- Notes**
- 1 : Switch the mode by the allows shown between the mode blocks. (Do not switch between the modes directly without an allow.)
  - 2 : The all modes can be switched to the stop mode or the wait mode and return to the source mode when the stop mode or the wait mode is ended.
  - 3 : Timer operates in the wait mode.
  - 4 : After STP instruction is released, the count source which had set by bit 2 (timer 12 count source selection bit) of the timer count source set register at executing the STP instruction is supplied to timer 1. Accordingly, when bit 0 of MISRG is "0" and the timer 12 count source selection bit is "0" (f(XIN)/16 or f(XCIN)/16), a delay of approximately 1 ms occurs automatically in the high/middle-speed mode. A delay of approximately 256 ms occurs automatically in the low-speed mode (at f(XIN) = 8 MHz, f(XCIN) = 32 kHz). When the timer 12 count source selection bit is "1" (f(XCIN)), a delay of approximately 16 ms occurs regardless of the operation mode.
  - 5 : Wait until oscillation stabilizes after oscillating the main clock XIN before the switching from the low-speed mode to middle/high-speed mode.
  - 6 : When the mode is switched to the middle-speed mode by the middle-speed mode automatic switch set bit of MISRG, the waiting time set by the middle-speed mode automatic switch wait time set bit is automatically generated, and then the mode is switched to the middle-speed mode.
  - 7 : The example assumes that 8 MHz is being applied to the XIN pin and 32 kHz to the XCIN pin. φ indicates the internal clock.

Fig. 60 State transitions of system clock

## Electrical characteristics

### Absolute maximum ratings

**Table 7 Absolute maximum ratings**

Symbol	Parameter	Conditions	Ratings	Unit
V <sub>CC</sub>	Power source voltage	All voltages are based on V <sub>SS</sub> .	-0.3 to 6.5	V
V <sub>I</sub>	Input voltage P00–P07, P10–P17, P20, P21, P24–P27, P30–P34, P40–P44, V <sub>REF</sub>	When an input voltage is measured, output transistors are cut off.	-0.3 to V <sub>CC</sub> +0.3	V
V <sub>I</sub>	Input voltage P22, P23		-0.3 to V <sub>CC</sub> +0.3	V
V <sub>I</sub>	Input voltage RESET, X <sub>IN</sub>		-0.3 to V <sub>CC</sub> +0.3	V
V <sub>I</sub>	Input voltage CNV <sub>SS</sub>		-0.3 to 8.0	V
V <sub>O</sub>	Output voltage P00–P07, P10–P17, P20, P21, P24–P27, P30–P34, P40–P44, X <sub>OUT</sub>		-0.3 to V <sub>CC</sub> +0.3	V
V <sub>O</sub>	Output voltage P22, P23		-0.3 to 5.8	V
P <sub>d</sub>	Power dissipation	T <sub>a</sub> = 25 °C	1000 <b>(Note)</b>	mW
T <sub>opr</sub>	Operating temperature	–	-20 to 85	°C
T <sub>stg</sub>	Storage temperature	–	-40 to 125	°C

**Note :** The rating becomes 300mW at the PRSP0042GA-A/B (42P2R-A/E) package.

## Recommended operating conditions

**Table 8 Recommended operating conditions**

(V<sub>CC</sub> = 2.7 to 5.5 V, T<sub>a</sub> = -20 to 85 °C, unless otherwise noted)

Symbol	Parameter		Limits			Unit
			Min.	Typ.	Max.	
V <sub>CC</sub>	Power source voltage	At 12.5 MHz (High-speed mode)	4.0	5.0	5.5	V
		At 12.5 MHz (Middle-speed mode), 6 MHz (High-speed mode) 32 kHz (Low-speed mode)	2.7	5.0	5.5	V
V <sub>SS</sub>	Power source voltage			0		V
V <sub>REF</sub>	A/D convert reference voltage		2.0		V <sub>CC</sub>	V
AV <sub>SS</sub>	Analog power source voltage			0		V
V <sub>IA</sub>	Analog input voltage	AN <sub>0</sub> –AN <sub>8</sub>	AV <sub>SS</sub>		V <sub>CC</sub>	V
V <sub>IH</sub>	“H” input voltage	P0 <sub>0</sub> –P0 <sub>7</sub> , P1 <sub>0</sub> –P1 <sub>7</sub> , P2 <sub>0</sub> –P2 <sub>7</sub> , P3 <sub>0</sub> –P3 <sub>4</sub> , P4 <sub>0</sub> –P4 <sub>4</sub>	0.8V <sub>CC</sub>		V <sub>CC</sub>	V
V <sub>IH</sub>	“H” input voltage	RESET, XIN, CNV <sub>SS</sub>	0.8V <sub>CC</sub>		V <sub>CC</sub>	V
V <sub>IL</sub>	“L” input voltage	P0 <sub>0</sub> –P0 <sub>7</sub> , P1 <sub>0</sub> –P1 <sub>7</sub> , P2 <sub>0</sub> –P2 <sub>7</sub> , P3 <sub>0</sub> –P3 <sub>4</sub> , P4 <sub>0</sub> –P4 <sub>4</sub>	0		0.2V <sub>CC</sub>	V
V <sub>IL</sub>	“L” input voltage	RESET, CNV <sub>SS</sub>	0		0.2V <sub>CC</sub>	V
V <sub>IL</sub>	“L” input voltage	XIN	0		0.16V <sub>CC</sub>	V
ΣIOH(peak)	“H” total peak output current (Note 1)	P0 <sub>0</sub> –P0 <sub>7</sub> , P1 <sub>0</sub> –P1 <sub>7</sub> , P3 <sub>0</sub> –P3 <sub>4</sub>			-80	mA
ΣIOH(peak)	“H” total peak output current (Note 1)	P2 <sub>0</sub> , P2 <sub>1</sub> , P2 <sub>4</sub> –P2 <sub>7</sub> , P4 <sub>0</sub> –P4 <sub>4</sub>			-80	mA
ΣIOL(peak)	“L” total peak output current (Note 1)	P0 <sub>0</sub> –P0 <sub>7</sub> , P3 <sub>0</sub> –P3 <sub>4</sub>			80	mA
ΣIOL(peak)	“L” total peak output current (Note 1)	P1 <sub>0</sub> –P1 <sub>7</sub>			120	mA
ΣIOL(peak)	“L” total peak output current (Note 1)	P2 <sub>0</sub> –P2 <sub>7</sub> , P4 <sub>0</sub> –P4 <sub>4</sub>			80	mA
ΣIOH(avg)	“H” total average output current (Note 1)	P0 <sub>0</sub> –P0 <sub>7</sub> , P1 <sub>0</sub> –P1 <sub>7</sub> , P3 <sub>0</sub> –P3 <sub>4</sub>			-40	mA
ΣIOH(avg)	“H” total average output current (Note 1)	P2 <sub>0</sub> , P2 <sub>1</sub> , P2 <sub>4</sub> –P2 <sub>7</sub> , P4 <sub>0</sub> –P4 <sub>4</sub>			-40	mA
ΣIOL(avg)	“L” total average output current (Note 1)	P0 <sub>0</sub> –P0 <sub>7</sub> , P3 <sub>0</sub> –P3 <sub>4</sub>			40	mA
ΣIOL(avg)	“L” total average output current (Note 1)	P1 <sub>0</sub> –P1 <sub>7</sub>			60	mA
ΣIOL(avg)	“L” total average output current (Note 1)	P2 <sub>0</sub> –P2 <sub>7</sub> , P4 <sub>0</sub> –P4 <sub>4</sub>			40	mA
IOH(peak)	“H” output voltage (Note 2)	P0 <sub>0</sub> –P0 <sub>7</sub> , P1 <sub>0</sub> –P1 <sub>7</sub> , P2 <sub>0</sub> , P2 <sub>1</sub> , P2 <sub>4</sub> –P2 <sub>7</sub> , P3 <sub>0</sub> –P3 <sub>4</sub> , P4 <sub>0</sub> –P4 <sub>4</sub>			-10	mA
IOL(peak)	“L” output voltage (Note 2)	P0 <sub>0</sub> –P0 <sub>7</sub> , P2 <sub>0</sub> –P2 <sub>7</sub> , P3 <sub>0</sub> –P3 <sub>4</sub> , P4 <sub>0</sub> –P4 <sub>4</sub>			10	mA
IOL(peak)	“L” output voltage (Note 2)	P1 <sub>0</sub> –P1 <sub>7</sub>			20	mA
IOH(avg)	“H” average output current (Note 3)	P0 <sub>0</sub> –P0 <sub>7</sub> , P1 <sub>0</sub> –P1 <sub>7</sub> , P2 <sub>0</sub> , P2 <sub>1</sub> , P2 <sub>4</sub> –P2 <sub>7</sub> , P3 <sub>0</sub> –P3 <sub>4</sub> , P4 <sub>0</sub> –P4 <sub>4</sub>			-5	mA
IOL(avg)	“L” average output current (Note 3)	P0 <sub>0</sub> –P0 <sub>7</sub> , P2 <sub>0</sub> –P2 <sub>7</sub> , P3 <sub>0</sub> –P3 <sub>4</sub> , P4 <sub>0</sub> –P4 <sub>4</sub>			5	mA
IOL(avg)	“L” average output current (Note 3)	P1 <sub>0</sub> –P1 <sub>7</sub>			15	mA
f(XIN)	Internal clock oscillation frequency (V <sub>CC</sub> = 4.0 to 5.5V) (Note 4)				12.5	MHz
f(XIN)	Internal clock oscillation frequency (V <sub>CC</sub> = 2.7 to 4.0V) (Note 4)				5V <sub>CC</sub> -7.5	MHz
f(XCIN)	Sub-clock input oscillation frequency (Note 4, 5)			32.768	50	kHz

**Note 1:** The total output current is the sum of all the currents flowing through all the applicable ports. The total average current is an average value measured over 100 ms. The total peak current is the peak value of all the currents.

**2:** The peak output current is the peak current flowing in each port.

**3:** The average output current IOL (avg), IOH (avg) in an average value measured over 100 ms.

**4:** When the oscillation frequency has a duty cycle of 50 %.

**5:** When using the microcomputer in low-speed mode, set the sub-clock input oscillation frequency on condition that f(XCIN) < f(XIN)/3.

## Electrical characteristics

**Table 9 Electrical characteristics (1)**
**(V<sub>CC</sub> = 2.7 to 5.5 V, V<sub>SS</sub> = 0 V, T<sub>a</sub> = -20 to 85 °C, unless otherwise noted)**

Symbol	Parameter	Test conditions	Limits			Unit
			Min.	Typ.	Max.	
VOH	"H" output voltage <b>(Note)</b> P00–P07, P10–P17, P20, P21 P24–P27, P30–P34, P40–P44	IOH = -10mA VCC=4.0–5.5V	VCC - 2.0			V
		IOH = -1.0mA VCC=2.7–5.5V	VCC - 1.0			V
VOL	"L" output voltage P00–P07, P20–P27, P30–P34 P40–P44	IOL = 10mA VCC=4.0–5.5V			2.0	V
		IOL = 1.0mA VCC=2.7–5.5V			1.0	V
VOL	"L" output voltage P10–P17	IOL = 20mA VCC=4.0–5.5V			2.0	V
		IOL = 10mA VCC=2.7–5.5V			1.0	V
VT+ – VT-	Hysteresis CNTR0, CNTR1, INT0–INT3			0.4		V
VT+ – VT-	Hysteresis RxD, SCLK1, SCLK2, SIN2			0.5		V
VT+ – VT-	Hysteresis RESET			0.5		V
I <sub>IH</sub>	"H" input current P00–P07, P10–P17, P20, P21, P24–P27, P30–P34, P40–P44	V <sub>I</sub> =V <sub>CC</sub> Pin floating, Pull-up Transistor "off"			5.0	μA
I <sub>IH</sub>	"H" input current RESET, CNV <sub>SS</sub>	V <sub>I</sub> =V <sub>CC</sub>			5.0	μA
I <sub>IH</sub>	"H" input current X <sub>IN</sub>	V <sub>I</sub> =V <sub>CC</sub>		4		μA
I <sub>IL</sub>	"L" input current P00–P07, P10–P17, P20–P27, P30–P34, P40–P44	V <sub>I</sub> =V <sub>SS</sub> Pin floating, Pull-up Transistor "off"			-5.0	μA
I <sub>IL</sub>	"L" input current RESET, CNV <sub>SS</sub>	V <sub>I</sub> =V <sub>SS</sub>			-5.0	μA
I <sub>IL</sub>	"L" input current X <sub>IN</sub>	V <sub>I</sub> =V <sub>SS</sub>		-4		μA
I <sub>IL</sub>	"L" input current (at Pull-up) P00–P07, P10–P17, P20–P27, P30–P34, P40–P44	V <sub>I</sub> =V <sub>SS</sub> V <sub>CC</sub> =5.0V	-25	-65	-120	μA
		V <sub>I</sub> =V <sub>SS</sub> V <sub>CC</sub> =3.0V	-8	-22	-40	μA
VRAM	RAM hold voltage	When clock stopped	2.0		5.5	V

**Note:** P25 is measured when the P25/TxD P-channel output disable bit of the UART control register (bit 4 of address 001B16) is "0".

**Table 10 Electrical characteristics (2)****(V<sub>CC</sub> = 2.7 to 5.5 V, V<sub>SS</sub> = 0 V, T<sub>a</sub> = -20 to 85 °C, unless otherwise noted)**

Symbol	Parameter	Test conditions	Limits			Unit	
			Min.	Typ.	Max.		
I <sub>CC</sub>	Power source current	High-speed mode f(X <sub>IN</sub> ) = 12.5 MHz f(X <sub>CIN</sub> ) = 32.768 kHz Output transistors "off"		6.0	12.0	mA	
		High-speed mode f(X <sub>IN</sub> ) = 8 MHz f(X <sub>CIN</sub> ) = 32.768 kHz Output transistors "off"		4.0	8.0	mA	
		High-speed mode f(X <sub>IN</sub> ) = 12.5 MHz (in WIT state) f(X <sub>CIN</sub> ) = 32.768 kHz Output transistors "off"		1.75	4.5	mA	
		High-speed mode f(X <sub>IN</sub> ) = 8 MHz (in WIT state) f(X <sub>CIN</sub> ) = 32.768 kHz Output transistors "off"		1.35	4.2	mA	
		Middle-speed mode f(X <sub>IN</sub> ) = 12.5 MHz f(X <sub>CIN</sub> ) = stopped Output transistors "off"		2.7	6.0	mA	
		Middle-speed mode f(X <sub>IN</sub> ) = 8 MHz f(X <sub>CIN</sub> ) = stopped Output transistors "off"		2.0	4.5	mA	
		Middle-speed mode f(X <sub>IN</sub> ) = 12.5 MHz (in WIT state) f(X <sub>CIN</sub> ) = stopped Output transistors "off"		1.65	4.2	mA	
		Middle-speed mode f(X <sub>IN</sub> ) = 8 MHz (in WIT state) f(X <sub>CIN</sub> ) = stopped Output transistors "off"		1.3	4.0	mA	
		Low-speed mode f(X <sub>IN</sub> ) = stopped f(X <sub>CIN</sub> ) = 32.768 kHz Output transistors "off"		40	150	μA	
		Low-speed mode f(X <sub>IN</sub> ) = stopped f(X <sub>CIN</sub> ) = 32.768 kHz (in WIT state) Output transistors "off"		30	100	μA	
		Low-speed mode (V <sub>CC</sub> =3V) f(X <sub>IN</sub> ) = stopped f(X <sub>CIN</sub> ) = 32.768 kHz Output transistors "off"		10	40	μA	
		Low-speed mode (V <sub>CC</sub> =3V) f(X <sub>IN</sub> ) = stopped f(X <sub>CIN</sub> ) = 32.768 kHz (in WIT state) Output transistors "off"		5.5	11	μA	
		Increment when A/D conversion is executed f(X <sub>IN</sub> ) = 8 MHz			600		μA
		All oscillation stopped (in STP state)	T <sub>a</sub> =25°C		0.1	1.0	μA
		Output transistors "off"	T <sub>a</sub> =85°C			10	μA

## A/D converter characteristics

**Table 11 A/D converter characteristics**

(V<sub>CC</sub> = 2.7 to 5.5 V, V<sub>SS</sub> = 0 V, T<sub>a</sub> = -20 to 85 °C, unless otherwise noted)

Symbol	Parameter	Test conditions	Limits			Unit
			Min.	Typ.	Max.	
–	Resolution				8	bit
ABS	Absolute accuracy	V <sub>CC</sub> =V <sub>REF</sub>			±3	LSB
t <sub>CONV</sub>	Conversion time				109	tc(XIN)
RLADDER	Ladder resistor			37		kΩ
I <sub>VREF</sub>	Reference power source input current	V <sub>REF</sub> =5.0V	50	135	200	μA
		V <sub>REF</sub> =3.0V	30	80	120	
I <sub>I(AD)</sub>	A/D port input current				5.0	μA

**Note :** As for AD translation accuracy, on the following operating conditions, accuracy may become low.

- (1) Since the analog circuit inside a microcomputer becomes sensitive to noise when V<sub>REF</sub> voltage is set up lower than V<sub>CC</sub> voltage, accuracy may become low rather than the case where V<sub>REF</sub> voltage and V<sub>CC</sub> voltage are set up to the same value.
- (2) When V<sub>REF</sub> voltage is less than [ 3.0V ], the accuracy at the time of low temperature may become extremely low compared with the time of room temperature. The use beyond V<sub>REF</sub>=3.0V is recommended in the system the use by the side of low temperature is assumed to be.

## Timing requirements

**Table 12 Timing requirements (1)**

(V<sub>CC</sub> = 4.0 to 5.5 V, V<sub>SS</sub> = 0 V, T<sub>a</sub> = -20 to 85 °C, unless otherwise noted)

Symbol	Parameter	Limits			Unit
		Min.	Typ.	Max.	
t <sub>w</sub> (RESET)	Reset input "L" pulse width	20			XIN cycle
t <sub>c</sub> (XIN)	External clock input cycle time	80			ns
t <sub>WH</sub> (XIN)	External clock input "H" pulse width	32			ns
t <sub>WL</sub> (XIN)	External clock input "L" pulse width	32			ns
t <sub>c</sub> (CNTR)	CNTR0, CNTR1 input cycle time	200			ns
t <sub>WH</sub> (CNTR)	CNTR0, CNTR1 input "H" pulse width	80			ns
t <sub>WL</sub> (CNTR)	CNTR0, CNTR1 input "L" pulse width	80			ns
t <sub>WH</sub> (INT)	INT0 to INT3 input "H" pulse width	80			ns
t <sub>WL</sub> (INT)	INT0 to INT3 input "L" pulse width	80			ns
t <sub>c</sub> (SCLK1)	Serial I/O1 clock input cycle time <b>(Note)</b>	800			ns
t <sub>WH</sub> (SCLK1)	Serial I/O1 clock input "H" pulse width <b>(Note)</b>	370			ns
t <sub>WL</sub> (SCLK1)	Serial I/O1 clock input "L" pulse width <b>(Note)</b>	370			ns
t <sub>su</sub> (RxD-SCLK1)	Serial I/O1 input setup time	220			ns
t <sub>h</sub> (SCLK1-RxD)	Serial I/O1 input hold time	100			ns
t <sub>c</sub> (SCLK2)	Serial I/O2 clock input cycle time	1000			ns
t <sub>WH</sub> (SCLK2)	Serial I/O2 clock input "H" pulse width	400			ns
t <sub>WL</sub> (SCLK2)	Serial I/O2 clock input "L" pulse width	400			ns
t <sub>su</sub> (SIN2-SCLK2)	Serial I/O2 clock input setup time	200			ns
t <sub>h</sub> (SCLK2-SIN2)	Serial I/O2 clock input hold time	200			ns

**Note** : When f(XIN) = 8 MHz and bit 6 of address 001A16 is "1" (clock synchronous).  
Divide this value by four when f(XIN) = 8 MHz and bit 6 of address 001A16 is "0" (UART).

**Table13 Timing requirements (2)**

(V<sub>CC</sub> = 2.7 to 5.5 V, V<sub>SS</sub> = 0 V, T<sub>a</sub> = -20 to 85 °C, unless otherwise noted)

Symbol	Parameter	Limits			Unit
		Min.	Typ.	Max.	
t <sub>w</sub> (RESET)	Reset input "L" pulse width	20			XIN cycle
t <sub>c</sub> (XIN)	External clock input cycle time	166			ns
t <sub>WH</sub> (XIN)	External clock input "H" pulse width	66			ns
t <sub>WL</sub> (XIN)	External clock input "L" pulse width	66			ns
t <sub>c</sub> (CNTR)	CNTR0, CNTR1 input cycle time	500			ns
t <sub>WH</sub> (CNTR)	CNTR0, CNTR1 input "H" pulse width	230			ns
t <sub>WL</sub> (CNTR)	CNTR0, CNTR1 input "L" pulse width	230			ns
t <sub>WH</sub> (INT)	INT0 to INT3 input "H" pulse width	230			ns
t <sub>WL</sub> (INT)	INT0 to INT3 input "L" pulse width	230			ns
t <sub>c</sub> (SCLK1)	Serial I/O1 clock input cycle time <b>(Note)</b>	2000			ns
t <sub>WH</sub> (SCLK1)	Serial I/O1 clock input "H" pulse width <b>(Note)</b>	950			ns
t <sub>WL</sub> (SCLK1)	Serial I/O1 clock input "L" pulse width <b>(Note)</b>	950			ns
t <sub>su</sub> (RxD-SCLK1)	Serial I/O1 input setup time	400			ns
t <sub>h</sub> (SCLK1-RxD)	Serial I/O1 input hold time	200			ns
t <sub>c</sub> (SCLK2)	Serial I/O2 clock input cycle time	2000			ns
t <sub>WH</sub> (SCLK2)	Serial I/O2 clock input "H" pulse width	950			ns
t <sub>WL</sub> (SCLK2)	Serial I/O2 clock input "L" pulse width	950			ns
t <sub>su</sub> (SIN2-SCLK2)	Serial I/O2 clock input setup time	400			ns
t <sub>h</sub> (SCLK2-SIN2)	Serial I/O2 clock input hold time	300			ns

**Note** : When f(XIN) = 4 MHz and bit 6 of address 001A16 is "1" (clock synchronous).  
Divide this value by four when f(XIN) = 4 MHz and bit 6 of address 001A16 is "0" (UART).



## Switching characteristics

**Table 14 Switching characteristics (1)**

(V<sub>CC</sub> = 4.0 to 5.5 V, V<sub>SS</sub> = 0 V, T<sub>a</sub> = -20 to 85 °C, unless otherwise noted)

Symbol	Parameter	Test conditions	Limits			Unit
			Min.	Typ.	Max.	
t <sub>WH</sub> (SCLK1)	Serial I/O1 clock output "H" pulse width	Fig. 61	tc(SCLK1)/2-30			ns
t <sub>WL</sub> (SCLK1)	Serial I/O1 clock output "L" pulse width		tc(SCLK1)/2-30			ns
t <sub>d</sub> (SCLK1-TxD)	Serial I/O1 output delay time ( <b>Note 1</b> )				140	ns
t <sub>v</sub> (SCLK1-TxD)	Serial I/O1 output valid time ( <b>Note 1</b> )		-30			ns
t <sub>r</sub> (SCLK1)	Serial I/O1 clock output rising time				30	ns
t <sub>f</sub> (SCLK1)	Serial I/O1 clock output falling time				30	ns
t <sub>WH</sub> (SCLK2)	Serial I/O2 clock output "H" pulse width		tc(SCLK2)/2-160			ns
t <sub>WL</sub> (SCLK2)	Serial I/O2 clock output "L" pulse width		tc(SCLK2)/2-160			ns
t <sub>d</sub> (SCLK2-SOUT2)	Serial I/O2 output delay time ( <b>Note 2</b> )				200	ns
t <sub>v</sub> (SCLK2-SOUT2)	Serial I/O2 output valid time ( <b>Note 2</b> )		0			ns
t <sub>f</sub> (SCLK2)	Serial I/O2 clock output falling time				30	ns
t <sub>r</sub> (CMOS)	CMOS output rising time ( <b>Note 3</b> )			10	30	ns
t <sub>f</sub> (CMOS)	CMOS output falling time ( <b>Note 3</b> )			10	30	ns

**Notes 1:** When the P25/TxD P-channel output disable bit of the UART control register (bit 4 of address 001B16) is "0".

**2:** When the P01/SOUT2 and P02/SCLK2 P-channel output disable bit of the Serial I/O2 control register 1 (bit 7 of address 001516) is "0".

**3:** The XOUT pin is excluded.

**Table 15 Switching characteristics (2)**

(V<sub>CC</sub> = 2.7 to 5.5 V, V<sub>SS</sub> = 0 V, T<sub>a</sub> = -20 to 85 °C, unless otherwise noted)

Symbol	Parameter	Test conditions	Limits			Unit
			Min.	Typ.	Max.	
t <sub>WH</sub> (SCLK1)	Serial I/O1 clock output "H" pulse width	Fig. 61	tc(SCLK1)/2-50			ns
t <sub>WL</sub> (SCLK1)	Serial I/O1 clock output "L" pulse width		tc(SCLK1)/2-50			ns
t <sub>d</sub> (SCLK1-TxD)	Serial I/O1 output delay time ( <b>Note 1</b> )				350	ns
t <sub>v</sub> (SCLK1-TxD)	Serial I/O1 output valid time ( <b>Note 1</b> )		-30			ns
t <sub>r</sub> (SCLK1)	Serial I/O1 clock output rising time				50	ns
t <sub>f</sub> (SCLK1)	Serial I/O1 clock output falling time				50	ns
t <sub>WH</sub> (SCLK2)	Serial I/O2 clock output "H" pulse width		tc(SCLK2)/2-240			ns
t <sub>WL</sub> (SCLK2)	Serial I/O2 clock output "L" pulse width		tc(SCLK2)/2-240			ns
t <sub>d</sub> (SCLK2-SOUT2)	Serial I/O2 output delay time ( <b>Note 2</b> )				400	ns
t <sub>v</sub> (SCLK2-SOUT2)	Serial I/O2 output valid time ( <b>Note 2</b> )		0			ns
t <sub>f</sub> (SCLK2)	Serial I/O2 clock output falling time				50	ns
t <sub>r</sub> (CMOS)	CMOS output rising time ( <b>Note 3</b> )			20	50	ns
t <sub>f</sub> (CMOS)	CMOS output falling time ( <b>Note 3</b> )			20	50	ns

**Notes 1:** When the P25/TxD P-channel output disable bit of the UART control register (bit 4 of address 001B16) is "0".

**2:** When the P01/SOUT2 and P02/SCLK2 P-channel output disable bit of the Serial I/O2 control register 1 (bit 7 of address 001516) is "0".

**3:** The XOUT pin is excluded.

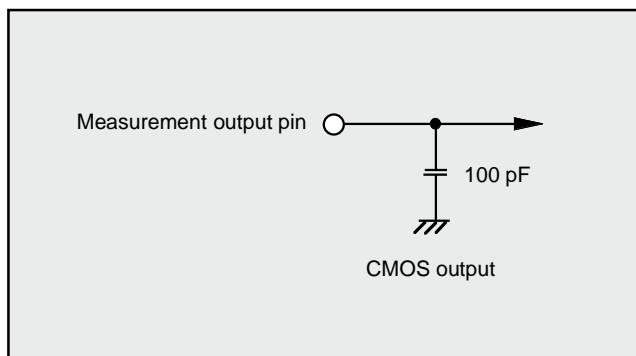

**Fig. 61 Circuit for measuring output switching characteristics**

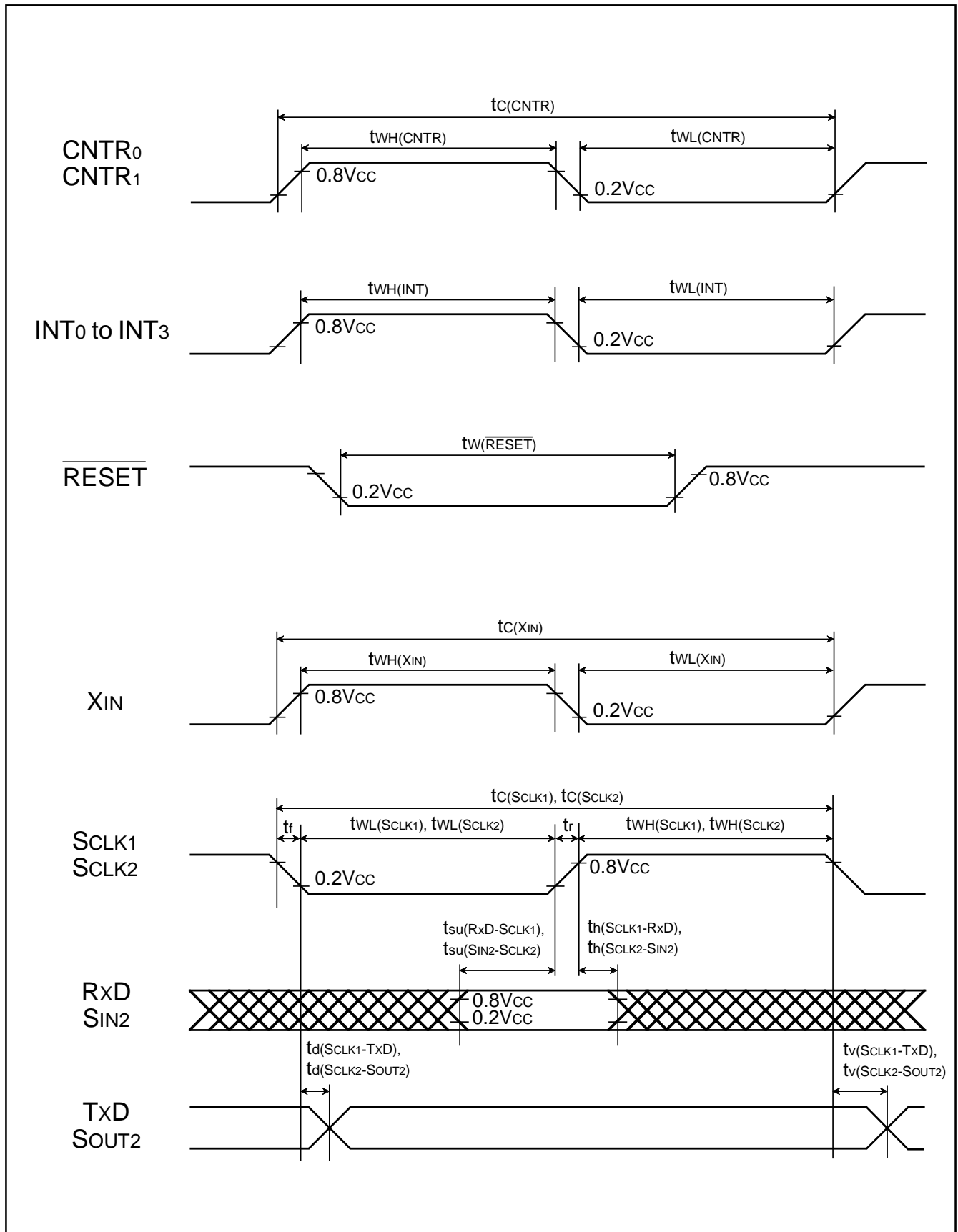

Fig. 62 Timing diagram

### PACKAGE OUTLINE

Diagrams showing the latest package dimensions and mounting information are available in the "Packages" section of the Renesas Technology website.

JEITA Package Code	RENEAS Code	Previous Code	MASS[Typ.]
P-SDIP42-13x36.72-1.78	PRDP0042BA-A	42P4B	4.1g

NOTE)  
 1. DIMENSIONS \*1 AND \*2 DO NOT INCLUDE MOLD FLASH.  
 2. DIMENSION \*3 DOES NOT INCLUDE TRIM OFFSET.

Reference Symbol	Dimension in Millimeters		
	Min	Nom	Max
[E]	14.94	15.24	15.54
D	36.5	36.7	36.9
E	12.85	13.0	13.15
A	—	—	5.5
A <sub>1</sub>	0.51	—	—
A <sub>2</sub>	—	3.8	—
b <sub>p</sub>	0.35	0.45	0.55
b <sub>2</sub>	0.63	0.73	1.03
b <sub>3</sub>	0.9	1.0	1.3
c	0.22	0.27	0.34
θ	0°	—	15°
e	1.528	1.778	2.028
L	3.0	—	—

JEITA Package Code	RENEAS Code	Previous Code	MASS[Typ.]
P-SSOP42-8.4x17.5-0.80	PRSP0042GA-B	42P2R-E	0.6g

NOTE)  
 1. DIMENSIONS \*1 AND \*2 DO NOT INCLUDE MOLD FLASH.  
 2. DIMENSION \*3 DOES NOT INCLUDE TRIM OFFSET.

Reference Symbol	Dimension in Millimeters		
	Min	Nom	Max
D	17.3	17.5	17.7
E	8.2	8.4	8.6
A <sub>2</sub>	—	2.0	—
A	—	—	2.4
A <sub>1</sub>	0.05	—	—
b <sub>p</sub>	0.25	0.3	0.4
c	0.13	0.15	0.2
θ	0°	—	10°
H <sub>E</sub>	11.63	11.93	12.23
e	0.65	0.8	0.95
y	—	—	0.15
L	0.3	0.5	0.7

## NOTES

### NOTES ON PROGRAMMING

#### 1. Processor Status Register

(1) Initializing of processor status register

Flags which affect program execution must be initialized after a reset. In particular, it is essential to initialize the T and D flags because they have an important effect on calculations.

<Reason>

After a reset, the contents of the processor status register (PS) are undefined except for the I flag which is "1".

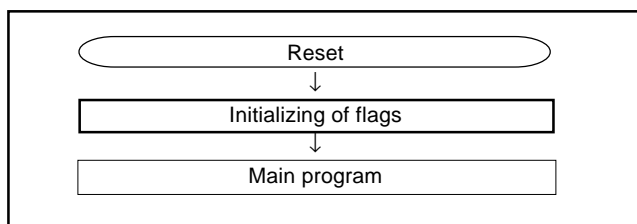

Fig 63. Initialization of processor status register

(2) How to reference the processor status register

To reference the contents of the processor status register (PS), execute the PHP instruction once then read the contents of (S+1). If necessary, execute the PLP instruction to return the PS to its original status.

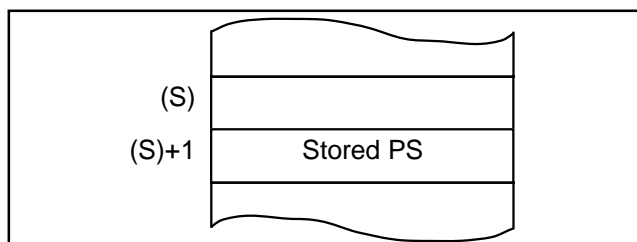

Fig 64. Stack memory contents after PHP instruction execution

#### 2. BRK instruction

(1) Interrupt priority level

When the BRK instruction is executed with the following conditions satisfied, the interrupt execution is started from the address of interrupt vector which has the highest priority.

- Interrupt request bit and interrupt enable bit are set to "1".
- Interrupt disable flag (I) is set to "1" to disable interrupt.

#### 3. Decimal calculations

(1) Execution of decimal calculations

The ADC and SBC are the only instructions which will yield proper decimal notation, set the decimal mode flag (D) to "1" with the SED instruction. After executing the ADC or SBC instruction, execute another instruction before executing the SEC, CLC, or CLD instruction.

(2) Notes on status flag in decimal mode

When decimal mode is selected, the values of three of the flags in the status register (the N, V, and Z flags) are invalid after a ADC or SBC instruction is executed.

The carry flag (C) is set to "1" if a carry is generated as a result of the calculation, or is cleared to "0" if a borrow is generated. To determine whether a calculation has generated a carry, the C flag must be initialized to "0" before each calculation. To check for a borrow, the C flag must be initialized to "1" before each calculation.

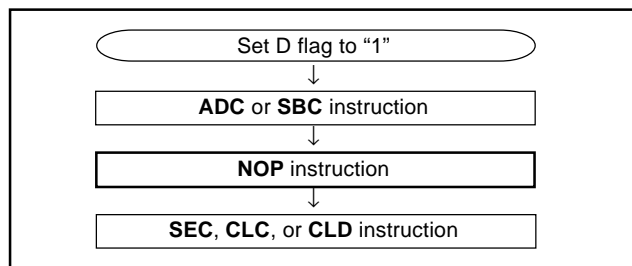

Fig 65. Execution of decimal calculations

#### 4. JMP instruction

When using the JMP instruction in indirect addressing mode, do not specify the last address on a page as an indirect address.

#### 5. Multiplication and Division Instructions

- The index X mode (T) and the decimal mode (D) flags do not affect the MUL and DIV instruction.
- The execution of these instructions does not change the contents of the processor status register.

#### 6. Ports

The contents of the port direction registers cannot be read. The following cannot be used:

- The data transfer instruction (LDA, etc.)
- The operation instruction when the index X mode flag (T) is "1"
- The addressing mode which uses the value of a direction register as an index
- The bit-test instruction (BBC or BBS, etc.) to a direction register
- The read-modify-write instructions (ROR, CLB, or SEB, etc.) to a direction register.

Use instructions such as LDM and STA, etc., to set the port direction registers.

#### 7. Instruction Execution Time

The instruction execution time can be obtained by multiplying the frequency of the internal clock  $\phi$  by the number of cycles mentioned in the 740 Family Software Manual.

The frequency of the internal clock  $\phi$  is the twice the XIN cycle in high-speed mode, 8 times the XIN cycle in middle-speed mode, and the twice the XCIN in low-speed mode.

#### 8. Reserved Area, Reserved Bit

Do not write any data to the reserved area in the SFR area and the special page. (Do not change the contents after reset.)

#### 9. CPU Mode Register

Be sure to fix bit 3 of the CPU mode register (address 003B16) to "1".

## NOTES ON PERIPHERAL FUNCTIONS

### Notes on Input and Output Ports

#### 1. Notes in standby state

In standby state<sup>\*1</sup>, do not make input levels of an I/O port “undefined”, especially for I/O ports of the N-channel open-drain. When setting the N-channel open-drain port as an output, do not make input levels of an I/O port “undefined”, too.

Pull-up (connect the port to VCC) or pull-down (connect the port to VSS) these ports through a resistor.

When determining a resistance value, note the following points:

- External circuit
- Variation of output levels during the ordinary operation

<Reason>

When setting as an input port with its direction register, the transistor becomes the OFF state, which causes the ports to be the high-impedance state.

Accordingly, the potential which is input to the input buffer in a microcomputer is unstable in the state that input levels of an I/O port are “undefined”. This may cause power source current.

In I/O ports of N-channel open-drain, when the contents of the port latch are “1”, even if it is set as an output port with its direction register, it becomes the same phenomenon as the case of an input port.

\*1 Standby state : stop mode by executing STP instruction  
wait mode by executing WIT instruction

#### 2. Modifying output data with bit managing instruction

When the port latch of an I/O port is modified with the bit managing instruction<sup>\*2</sup>, the value of the unspecified bit may be changed.

<Reason>

The bit managing instructions are read-modify-write form instructions for reading and writing data by a byte unit.

Accordingly, when these instructions are executed on a bit of the port latch of an I/O port, the following is executed to all bits of the port latch.

- As for bit which is set for input port:  
The pin state is read in the CPU, and is written to this bit after bit managing.
- As for bit which is set for output port:  
The bit value is read in the CPU, and is written to this bit after bit managing.

Note the following:

- Even when a port which is set as an output port is changed for an input port, its port latch holds the output data.
- As for a bit of which is set for an input port, its value may be changed even when not specified with a bit managing instruction in case where the pin state differs from its port latch contents.

\*2 Bit managing instructions : SEB and CLB instructions

## Termination of Unused Pins

### 1. Terminate unused pins

(1) I/O ports :

- Set the I/O ports for the input mode and connect them to VCC or VSS through each resistor of 1 kΩ to 10 kΩ. In the port which can select a internal pull-up resistor, the internal pull-up resistor can be used.

Set the I/O ports for the output mode and open them at “L” or “H”.

- When opening them in the output mode, the input mode of the initial status remains until the mode of the ports is switched over to the output mode by the program after reset. Thus, the potential at these pins is undefined and the power source current may increase in the input mode. With regard to an effects on the system, thoroughly perform system evaluation on the user side.
- Since the direction register setup may be changed because of a program runaway or noise, set direction registers by program periodically to increase the reliability of program.

(2) The AVSS pin when not using the A/D converter :

- When not using the A/D converter, handle a power source pin for the A/D converter, AVSS pin as follows:

AVSS: Connect to the VSS pin.

### 2. Termination remarks

(1) Input ports and I/O ports :

Do not open in the input mode.

<Reason>

- The power source current may increase depending on the firststage circuit.
- An effect due to noise may be easily produced as compared with proper termination (1) in 1 shown on the above.

(2) I/O ports :

When setting for the input mode, do not connect to VCC or VSS directly.

<Reason>

If the direction register setup changes for the output mode because of a program runaway or noise, a short circuit may occur between a port and VCC (or VSS).

(3) I/O ports :

When setting for the input mode, do not connect multiple ports in a lump to VCC or VSS through a resistor.

<Reason>

If the direction register setup changes for the output mode because of a program runaway or noise, a short circuit may occur between ports.

- At the termination of unused pins, perform wiring at the shortest possible distance (20 mm or less) from microcomputer pins.

## Notes on Interrupts

### 1. Change of relevant register settings

When the setting of the following registers or bits is changed, the interrupt request bit may be set to "1". When not requiring the interrupt occurrence synchronized with these setting, take the following sequence.

- Interrupt edge selection register (address 003A16)
- Timer XY mode register (address 002316)

Set the above listed registers or bits as the following sequence.

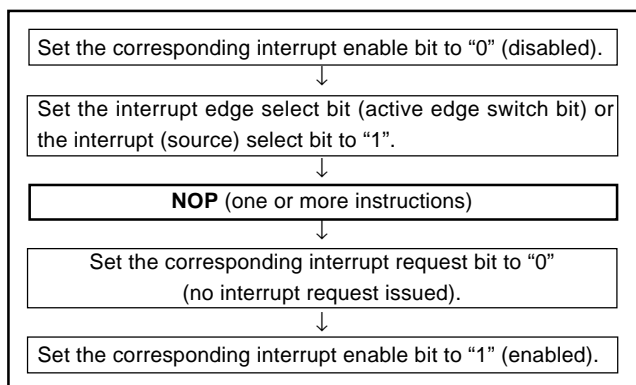

Fig 66. Sequence of changing relevant register

<Reason>

When setting the followings, the interrupt request bit may be set to "1".

- When setting external interrupt active edge  
Concerned register: Interrupt edge selection register (address 003A16)  
Timer XY mode register (address 002316)
- When switching interrupt sources of an interrupt vector address where two or more interrupt sources are allocated.  
Concerned register: Interrupt edge selection register (address 003A16)

### 2. Check of interrupt request bit

When executing the BBC or BBS instruction to an interrupt request bit of an interrupt request register immediately after this bit is set to "0" by using a data transfer instruction, execute one or more instructions before executing the BBC or BBS instruction.

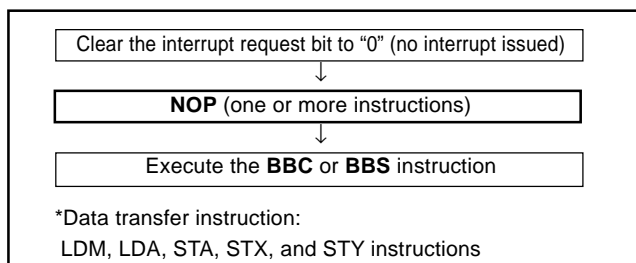

Fig 67. Sequence of check of interrupt request bit

<Reason>

If the BBC or BBS instruction is executed immediately after an interrupt request bit of an interrupt request register is cleared to "0", the value of the interrupt request bit before being cleared to "0" is read.

## Notes on Timer

- If a value n (between 0 and 255) is written to a timer latch, the frequency division ratio is  $1/(n+1)$ .
- When switching the count source by the timer 12, X and Y count source selection bits, the value of timer count is altered in unconsiderable amount owing to generating of thin pulses in the count input signals.  
Therefore, select the timer count source before set the value to the prescaler and the timer.

## Notes on Serial Interface

### 1. Notes when selecting clock synchronous serial I/O (Serial I/O1)

(1) Stop of transmission operation

Clear the serial I/O1 enable bit and the transmit enable bit to "0" (Serial I/O1 and transmit disabled).

<Reason>

Since transmission is not stopped and the transmission circuit is not initialized even if only the serial I/O1 enable bit is cleared to "0" (Serial I/O1 disabled), the internal transmission is running (in this case, since pins TxD, RxD, SCLK1, and  $\overline{\text{SRDY1}}$  function as I/O ports, the transmission data is not output). When data is written to the transmit buffer register in this state, data starts to be shifted to the transmit shift register. When the serial I/O1 enable bit is set to "1" at this time, the data during internally shifting is output to the TxD pin and an operation failure occurs.

(2) Stop of receive operation

Clear the receive enable bit to "0" (receive disabled), or clear the serial I/O1 enable bit to "0" (Serial I/O1 disabled).

(3) Stop of transmit/receive operation

Clear the transmit enable bit and receive enable bit to "0" simultaneously (transmit and receive disabled).

(when data is transmitted and received in the clock synchronous serial I/O mode, any one of data transmission and reception cannot be stopped.)

<Reason>

In the clock synchronous serial I/O mode, the same clock is used for transmission and reception. If any one of transmission and reception is disabled, a bit error occurs because transmission and reception cannot be synchronized.

In this mode, the clock circuit of the transmission circuit also operates for data reception. Accordingly, the transmission circuit does not stop by clearing only the transmit enable bit to "0" (transmit disabled). Also, the transmission circuit is not initialized by clearing the serial I/O1 enable bit to "0" (Serial I/O1 disabled) (refer to (1) in 1).

(4)  $\overline{\text{SRDY1}}$  output of reception side (Serial I/O1)

When signals are output from the  $\overline{\text{SRDY1}}$  pin on the reception side by using an external clock in the clock synchronous serial I/O mode, set all of the receive enable bit, the  $\overline{\text{SRDY1}}$  output enable bit, and the transmit enable bit to "1" (transmit enabled).

## 2. Notes when selecting clock asynchronous serial I/O (Serial I/O1)

### (1) Stop of transmission operation

Clear the transmit enable bit to "0" (transmit disabled).

<Reason>

Since transmission is not stopped and the transmission circuit is not initialized even if only the serial I/O1 enable bit is cleared to "0" (Serial I/O1 disabled), the internal transmission is running (in this case, since pins TxD, RxD, SCLK1, and  $\overline{\text{SRDY1}}$  function as I/O ports, the transmission data is not output). When data is written to the transmit buffer register in this state, data starts to be shifted to the transmit shift register. When the serial I/O1 enable bit is set to "1" at this time, the data during internally shifting is output to the TxD pin and an operation failure occurs.

### (2) Stop of receive operation

Clear the receive enable bit to "0" (receive disabled).

### (3) Stop of transmit/receive operation

Only transmission operation is stopped.

Clear the transmit enable bit to "0" (transmit disabled).

<Reason>

Since transmission is not stopped and the transmission circuit is not initialized even if only the serial I/O1 enable bit is cleared to "0" (Serial I/O1 disabled), the internal transmission is running (in this case, since pins TxD, RxD, SCLK1, and  $\overline{\text{SRDY1}}$  function as I/O ports, the transmission data is not output). When data is written to the transmit buffer register in this state, data starts to be shifted to the transmit shift register. When the serial I/O1 enable bit is set to "1" at this time, the data during internally shifting is output to the TxD pin and an operation failure occurs.

Only receive operation is stopped.

Clear the receive enable bit to "0" (receive disabled).

## 3. Setting serial I/O1 control register again (Serial I/O1)

Set the serial I/O1 control register again after the transmission and the reception circuits are reset by clearing both the transmit enable bit and the receive enable bit to "0".

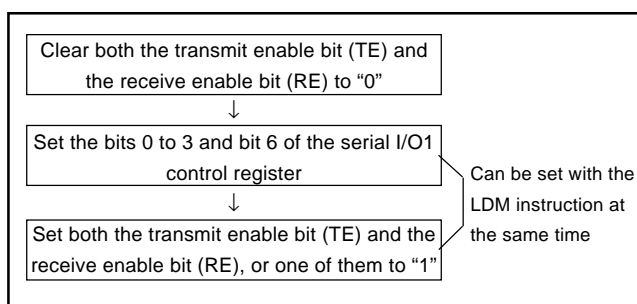

Fig 68. Sequence of setting serial I/O1 control register again

## 4. Data transmission control with referring to transmit shift register completion flag (Serial I/O1)

The transmit shift register completion flag changes from "1" to "0" with a delay of 0.5 to 1.5 shift clocks. When data transmission is controlled with referring to the flag after writing the data to the transmit buffer register, note the delay.

## 5. Transmit interrupt request when transmit enable bit is set (Serial I/O1)

When the transmit interrupt is used, set the transmit interrupt enable bit to transmit enabled as shown in the following sequence.

(1) Set the interrupt enable bit to "0" (disabled) with CLB instruction.

(2) Prepare serial I/O for transmission/reception.

(3) Set the interrupt request bit to "0" with CLB instruction after 1 or more instruction has been executed.

(4) Set the interrupt enable bit to "1" (enabled).

<Reason>

When the transmission enable bit is set to "1", the transmit buffer empty flag and transmit shift register completion flag are set to "1". The interrupt request is generated and the transmission interrupt request bit is set regardless of which of the two timings listed below is selected as the timing for the transmission interrupt to be generated.

- Transmit buffer empty flag is set to "1"
- Transmit shift register completion flag is set to "1"

## 6. Transmission control when external clock is selected (Serial I/O1 clock synchronous mode)

When an external clock is used as the synchronous clock for data transmission, set the transmit enable bit to "1" at "H" of the SCLK1 input level. Also, write the transmit data to the transmit buffer register (serial I/O shift register) at "H" of the SCLK1 input level.

## 7. Transmit data writing (Serial I/O2)

In the clock synchronous serial I/O, when selecting an external clock as synchronous clock, write the transmit data to the serial I/O2 register (serial I/O shift register) at "H" of the transfer clock input level.

## Notes on PWM

The PWM starts after the PWM enable bit is set to enable and "L" level is output from the PWM pin.

The length of this "L" level output is as follows:

$$\frac{n+1}{2 \times f(XIN)} \quad (s) \quad \text{(Count source selection bit = "0", where n is the value set in the prescaler)}$$

$$\frac{n+1}{f(XIN)} \quad (s) \quad \text{(Count source selection bit = "1", where n is the value set in the prescaler)}$$

## Notes on A/D Converter

### 1. Analog input pin

Make the signal source impedance for analog input low, or equip an analog input pin with an external capacitor of 0.01  $\mu\text{F}$  to 1  $\mu\text{F}$ . Further, be sure to verify the operation of application products on the user side.

<Reason>

An analog input pin includes the capacitor for analog voltage comparison. Accordingly, when signals from signal source with high impedance are input to an analog input pin, charge and discharge noise generates. This may cause the A/D conversion precision to be worse.

### 2. A/D converter power source pin

The AVss pin is A/D converter power source pin. Regardless of using the A/D conversion function or not, connect it as following :

- AVss : Connect to the Vss line

<Reason>

If the AVss pin is opened, the microcomputer may have a failure because of noise or others.

### 3. Clock frequency during A/D conversion

The comparator consists of a capacity coupling, and a charge of the capacity will be lost if the clock frequency is too low. Thus, make sure the following during an A/D conversion.

- $f(\text{XIN})$  is 500 kHz or more in middle-/high-speed mode.
- Do not execute the STP instruction.
- When the A/D converter is operated at low-speed mode,  $f(\text{XIN})$  do not have the lower limit of frequency, because of the A/D converter has a built-in self-oscillation circuit.

## Notes on Watchdog Timer

- Make sure that the watchdog timer does not underflow while waiting Stop release, because the watchdog timer keeps counting during that term.
- When the STP instruction function selection bit has been set to "1", it is impossible to switch it to "0" by a program.

## Notes on RESET Pin

### 1. Connecting capacitor

In case where the RESET signal rise time is long, connect a ceramic capacitor or others across the RESET pin and the Vss pin. Use a 1000 pF or more capacitor for high frequency use. When connecting the capacitor, note the following :

- Make the length of the wiring which is connected to a capacitor as short as possible.
- Be sure to verify the operation of application products on the user side.

<Reason>

If the several nanosecond or several ten nanosecond impulse noise enters the RESET pin, it may cause a microcomputer failure.

### 2. Reset release after power on

When releasing the reset after power on, such as power-on reset, release reset after XIN passes more than 20 cycles in the state where the power supply voltage is 2.7 V or more and the XIN oscillation is stable.

<Reason>

To release reset, the RESET pin must be held at an "L" level for 20 cycles or more of XIN in the state where the power source voltage is between 2.7 V and 5.5 V, and XIN oscillation is stable.

## Notes on Using Stop Mode

### 1. Register setting

Since values of the prescaler 12 and Timer 1 are automatically reloaded when returning from the stop mode, set them again, respectively. (When the oscillation stabilizing time set after STP instruction released bit is "0")

When using the oscillation stabilizing time set after STP instruction released bit set to "1", evaluate time to stabilize oscillation of the used oscillator and set the value to the timer 1 and prescaler 12.

### 2. Clock restoration

After restoration from the stop mode to the normal mode by an interrupt request, the contents of the CPU mode register previous to the STP instruction execution are retained. Accordingly, if both main clock and sub clock were oscillating before execution of the STP instruction, the oscillation of both clocks is resumed at restoration.

In the above case, when the main clock side is set as a system clock, the oscillation stabilizing time for approximately 8,000 cycles of the XIN input is reserved at restoration from the stop mode. At this time, note that the oscillation on the sub clock side may not be stabilized even after the lapse of the oscillation stabilizing time of the main clock side.

## Notes on Wait Mode

- Clock restoration

If the wait mode is released by a reset when XCIN is set as the system clock and XIN oscillation is stopped during execution of the WIT instruction, XCIN oscillation stops, XIN oscillations starts, and XIN is set as the system clock.

In the above case, the RESET pin should be held at "L" until the oscillation is stabilized.

## Notes on Restarting Oscillation

- Restarting oscillation

Usually, when the MCU stops the clock oscillation by STP instruction and the STP instruction has been released by an external interrupt source, the fixed values of Timer 1 and Prescaler 12 (Timer 1 = "0116", Prescaler 12 = "FF16") are automatically reloaded in order for the oscillation to stabilize.

The user can inhibit the automatic setting by writing "1" to bit 0 of MISRG (address 003816).

However, by setting this bit to "1", the previous values, set just before the STP instruction was executed, will remain in Timer 1 and Prescaler 12. Therefore, you will need to set an appropriate value to each register, in accordance with the oscillation stabilizing time, before executing the STP instruction.

<Reason>

Oscillation will restart when an external interrupt is received.

However, internal clock  $\phi$  is supplied to the CPU only when Timer 1 starts to underflow. This ensures time for the clock oscillation using the ceramic resonators to be stabilized.



## Handling of Source Pins

In order to avoid a latch-up occurrence, connect a capacitor suitable for high frequencies as bypass capacitor between power source pin (VCC pin) and GND pin (VSS pin) and between power source pin (VCC pin) and analog power source input pin (AVSS pin). Besides, connect the capacitor to as close as possible. For bypass capacitor which should not be located too far from the pins to be connected, a ceramic capacitor of 0.01  $\mu\text{F}$ –0.1  $\mu\text{F}$  is recommended.

## Power Source Voltage

When the power source voltage value of a microcomputer is less than the value which is indicated as the recommended operating conditions, the microcomputer does not operate normally and may perform unstable operation.

In a system where the power source voltage drops slowly when the power source voltage drops or the power supply is turned off, reset a microcomputer when the power source voltage is less than the recommended operating conditions and design a system not to cause errors to the system by this unstable operation.

## Product Shipped in Blank

As for the product shipped in blank, Renesas does not perform the writing test to user ROM area after the assembly process though the QzROM writing test is performed enough before the assembly process. Therefore, a writing error of approx.0.1 % may occur. Moreover, please note the contact of cables and foreign bodies on a socket, etc. because a writing environment may cause some writing errors.

## QzROM Version

Connect the CNVSS/VPP pin the shortest possible to the GND pattern which is supplied to the VSS pin of the microcomputer.

In addition connecting an approximately 5 k $\Omega$  resistor in series to the GND could improve noise immunity. In this case as well as the above mention, connect the pin the shortest possible to the GND pattern which is supplied to the VSS pin of the microcomputer.

<Reason>

The CNVSS/VPP pin is the power source input pin for the built-in QzROM. When programming in the QzROM, the impedance of the VPP pin is low to allow the electric current for writing to flow into the built-in QzROM. Because of this, noise can enter easily. If noise enters the VPP pin, abnormal instruction codes or data are read from the QzROM, which may cause a program runaway.

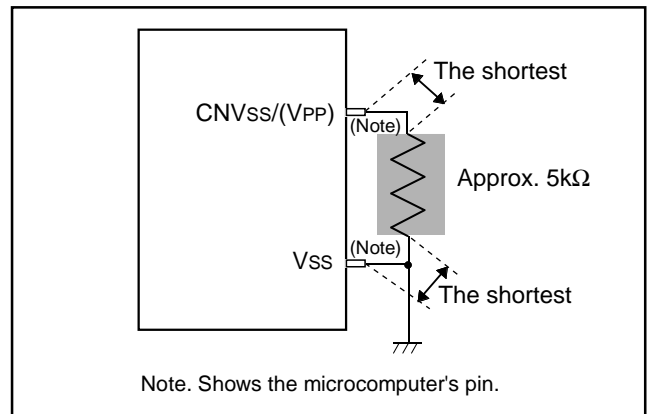

Fig 68. Wiring for the CNVSS/VPP

## Notes On QzROM Writing Orders

When ordering the QzROM product shipped after writing, submit the mask file (extension: .msk) which is made by the mask file converter MM.

- Be sure to set the ROM option data\* setup when making the mask file by using the mask file converter MM.. The ROM code protect is specified according to the ROM option data\* in the mask file which is submitted at ordering. Note that the mask file which has nothing at the ROM option data\* or has the data other than "0016" and "FF16" can not be accepted.
- Set "FF16" to the ROM code protect address in ROM data regardless of the presence or absence of a protect. When data other than "FF16" is set, we may ask that the ROM data be submitted again.

\* ROM option data: mask option noted in MM

## DATA REQUIRED FOR QzROM WRITING ORDERS

The following are necessary when ordering a QzROM product shipped after writing:

1. QzROM Writing Confirmation Form\*
2. Mark Specification Form\*
3. ROM data.....Mask file

\* For the QzROM writing confirmation form and the mark specification form, refer to the "Renesas Technology Corp."

Homepage (<http://www.renesas.com/homepage.jsp>).

Note that we cannot deal with special font marking (customer's trademark etc.) in QzROM microcomputer.

REVISION HISTORY

3858 Group Data Sheet

Rev.	Date	Description	
		Page	Summary
1.00	Jan.28, 2005	–	First edition issued
1.01	May.11, 2005	5 10 60 61 65	Table 2 added ROM code protect address, Notes added Fig. 8 partly revised QzROM Version, Notes On QzROM Writing Orders, Notes On ROM Code Protect, DATA REQUIRED FOR QzROM WRITING ORDERS added Table 7 partly revised Table 12 partly revised
1.10	Apr.3, 2006	– – 3 10 12 15 17 53 56 57 59 61 64 69 70 to 75	“Under development” deleted Package name is revised “42P2R-A/E” → “PRSP0042GA-B” Table 1; CNVss Functions: “and is shared with ..... the built-in QzROM” added P3, P4 Functions: “•8-bit I/O port” → “•5-bit I/O port” ROM Code Protect Address; “the Mask option set up when ordering.” → “ROM option setup ..... when ordering.” revised Table 5 “A/D converter input” → “A/D conversion input” Fig. 12 revised Fig. 14; b7 to b5 of registers PULL3 and PULL4 revised WATCHDOG TIMER revised CLOCK GENERATING CIRCUIT revised Fig. 59 revised Table 7; Input voltage P22, P23 Ratings: “5.8” → “VCC +0.3” Input voltage CNVss Ratings: “VCC +0.3” → “8.0” Table 9; f(XCIN), Note 4 added Table 13 “VCC = 4.0 to 5.5 V” → “VCC = 2.7 to 5.5 V” PACKAGE OUTLINE revised NOTES added (The last NOTES ON PROGRAMMING and NOTES ON USAGE deleted)
1.11	Dec.18,2008	1,4,5,59 23 52 55 63 72 73	PRSP0042GA-B → PRSP0042GA-A/B Fig. 17: Main clock division ration selection bit XIN “1” deleted “Initial Value of Watchdog Timer” partly added When bit 7 of the watchdog timer control register is “0”: 65.536 ms at XIN = 16 MHz frequency → 131.072 ms at XIN = 8 MHz frequency “1”: 256 μs at XIN = 16 MHz frequency → 512 μs at XIN = 8 MHz frequency (2) Wait mode partly revised: “When releasing the STP state, the input of the prescaler 12 and timer 1 is connected to the count source which had set at executing the STP instruction and the prescaler 12 and timer 1 will start counting” Table 11 A/D converter characteristics: “Ta = 25°C ” deleted from the test conditions of absolute accuracy Notes on Watchdog Timer: “STP instruction disable bit” → “STP instruction function selection bit” Notes on QzROM Writing Orders revised

Notes:

1. This document is provided for reference purposes only so that Renesas customers may select the appropriate Renesas products for their use. Renesas neither makes warranties or representations with respect to the accuracy or completeness of the information contained in this document nor grants any license to any intellectual property rights or any other rights of Renesas or any third party with respect to the information in this document.
2. Renesas shall have no liability for damages or infringement of any intellectual property or other rights arising out of the use of any information in this document, including, but not limited to, product data, diagrams, charts, programs, algorithms, and application circuit examples.
3. You should not use the products or the technology described in this document for the purpose of military applications such as the development of weapons of mass destruction or for the purpose of any other military use. When exporting the products or technology described herein, you should follow the applicable export control laws and regulations, and procedures required by such laws and regulations.
4. All information included in this document such as product data, diagrams, charts, programs, algorithms, and application circuit examples, is current as of the date this document is issued. Such information, however, is subject to change without any prior notice. Before purchasing or using any Renesas products listed in this document, please confirm the latest product information with a Renesas sales office. Also, please pay regular and careful attention to additional and different information to be disclosed by Renesas such as that disclosed through our website. (<http://www.renesas.com>)
5. Renesas has used reasonable care in compiling the information included in this document, but Renesas assumes no liability whatsoever for any damages incurred as a result of errors or omissions in the information included in this document.
6. When using or otherwise relying on the information in this document, you should evaluate the information in light of the total system before deciding about the applicability of such information to the intended application. Renesas makes no representations, warranties or guarantees regarding the suitability of its products for any particular application and specifically disclaims any liability arising out of the application and use of the information in this document or Renesas products.
7. With the exception of products specified by Renesas as suitable for automobile applications, Renesas products are not designed, manufactured or tested for applications or otherwise in systems the failure or malfunction of which may cause a direct threat to human life or create a risk of human injury or which require especially high quality and reliability such as safety systems, or equipment or systems for transportation and traffic, healthcare, combustion control, aerospace and aeronautics, nuclear power, or undersea communication transmission. If you are considering the use of our products for such purposes, please contact a Renesas sales office beforehand. Renesas shall have no liability for damages arising out of the uses set forth above.
8. Notwithstanding the preceding paragraph, you should not use Renesas products for the purposes listed below:
  - (1) artificial life support devices or systems
  - (2) surgical implantations
  - (3) healthcare intervention (e.g., excision, administration of medication, etc.)
  - (4) any other purposes that pose a direct threat to human lifeRenesas shall have no liability for damages arising out of the uses set forth in the above and purchasers who elect to use Renesas products in any of the foregoing applications shall indemnify and hold harmless Renesas Technology Corp., its affiliated companies and their officers, directors, and employees against any and all damages arising out of such applications.
9. You should use the products described herein within the range specified by Renesas, especially with respect to the maximum rating, operating supply voltage range, movement power voltage range, heat radiation characteristics, installation and other product characteristics. Renesas shall have no liability for malfunctions or damages arising out of the use of Renesas products beyond such specified ranges.
10. Although Renesas endeavors to improve the quality and reliability of its products, IC products have specific characteristics such as the occurrence of failure at a certain rate and malfunctions under certain use conditions. Please be sure to implement safety measures to guard against the possibility of physical injury, and injury or damage caused by fire in the event of the failure of a Renesas product, such as safety design for hardware and software including but not limited to redundancy, fire control and malfunction prevention, appropriate treatment for aging degradation or any other applicable measures. Among others, since the evaluation of microcomputer software alone is very difficult, please evaluate the safety of the final products or system manufactured by you.
11. In case Renesas products listed in this document are detached from the products to which the Renesas products are attached or affixed, the risk of accident such as swallowing by infants and small children is very high. You should implement safety measures so that Renesas products may not be easily detached from your products. Renesas shall have no liability for damages arising out of such detachment.
12. This document may not be reproduced or duplicated, in any form, in whole or in part, without prior written approval from Renesas.
13. Please contact a Renesas sales office if you have any questions regarding the information contained in this document, Renesas semiconductor products, or if you have any other inquiries.



**RENESAS SALES OFFICES**

<http://www.renesas.com>

Refer to "<http://www.renesas.com/en/network>" for the latest and detailed information.

**Renesas Technology America, Inc.**  
450 Holger Way, San Jose, CA 95134-1368, U.S.A  
Tel: <1> (408) 382-7500, Fax: <1> (408) 382-7501

**Renesas Technology Europe Limited**  
Dukes Meadow, Millboard Road, Bourne End, Buckinghamshire, SL8 5FH, U.K.  
Tel: <44> (1628) 585-100, Fax: <44> (1628) 585-900

**Renesas Technology (Shanghai) Co., Ltd.**  
Unit 204, 205, AZIACenter, No.1233 Lujiazui Ring Rd, Pudong District, Shanghai, China 200120  
Tel: <86> (21) 5877-1818, Fax: <86> (21) 6887-7858/7898

**Renesas Technology Hong Kong Ltd.**  
7th Floor, North Tower, World Finance Centre, Harbour City, Canton Road, Tsimshatsui, Kowloon, Hong Kong  
Tel: <852> 2265-6688, Fax: <852> 2377-3473

**Renesas Technology Taiwan Co., Ltd.**  
10th Floor, No.99, Fushing North Road, Taipei, Taiwan  
Tel: <886> (2) 2715-2888, Fax: <886> (2) 3518-3399

**Renesas Technology Singapore Pte. Ltd.**  
1 Harbour Front Avenue, #06-10, Keppel Bay Tower, Singapore 098632  
Tel: <65> 6213-0200, Fax: <65> 6278-8001

**Renesas Technology Korea Co., Ltd.**  
Kukje Center Bldg. 18th Fl., 191, 2-ka, Hangang-ro, Yongsan-ku, Seoul 140-702, Korea  
Tel: <82> (2) 796-3115, Fax: <82> (2) 796-2145

**Renesas Technology Malaysia Sdn. Bhd**  
Unit 906, Block B, Menara Amcorp, Amcorp Trade Centre, No.18, Jln Persiaran Barat, 46050 Petaling Jaya, Selangor Darul Ehsan, Malaysia  
Tel: <603> 7955-9390, Fax: <603> 7955-9510