

用途：用于高频小功率放大。

Purpose: High frequency low power amplifier applications.

特点：大电流特性好，饱和压降低。

Features: Excellent high current linearity, low saturation voltage.

极限参数/Absolute maximum ratings(Ta=25°C)

参数符号 Symbol	数值 Rating	单位 Unit
$V_{CB0}$	-30	V
$V_{CE0}$	-30	V
$V_{EB0}$	-5.0	V
$I_C$	-1.5	A
$P_C$	0.9	W
$T_j$	150	°C
$T_{stg}$	-55~150	°C

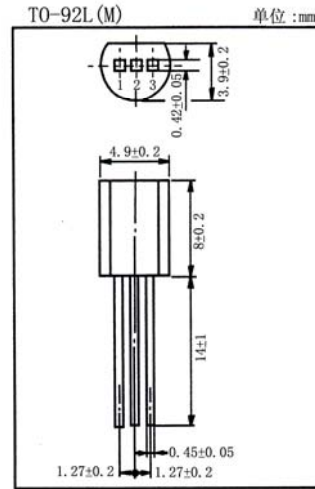

引脚： 1. E 2. C 3. B

电性能参数/Electrical characteristics(Ta=25°C)

参数符号 Symbol	测试条件 Test condition	数值 Rating			单位 Unit
		最小值 Min	典型值 Typ	最大值 Max	
$I_{CB0}$	$V_{CB}=-30V$ $I_E=0$			-0.1	$\mu A$
$I_{EB0}$	$V_{EB}=-5.0V$ $I_C=0$			-0.1	$\mu A$
$h_{FE}$	$V_{CE}=-2.0V$ $I_C=-0.5A$	100		400	
$V_{CE(sat)}$	$I_C=-1.5A$ $I_B=-30mA$			-2.0	V
$f_T$	$V_{CE}=-5.0V$ $I_C=-0.1A$	50			MHz
$C_{ob}$	$V_{CB}=-10V$ $I_E=0$ $f=1.0MHz$			80	pF

$h_{FE}$  分档/ $h_{FE}$  Classifications: 0:100~240 Y:150~400

