

用途:用于音频放大、激励级放大。/Purpose: Audio frequency amplifier and driver stage.

特点:集电极耗散功率大, h_{FE} 高, V_{CEO} 高。/Features: High total power dissipation, high h_{FE} and high V_{CEO} .

极限参数/Absolute maximum ratings ($T_a=25^\circ\text{C}$)

参数符号 Symbol	数值 Rating	单位 Unit
V_{CB0}	-60	V
V_{CE0}	-60	V
V_{EB0}	-5.0	V
I_C	-300	mA
I_B	-60	mA
P_C	600	mW
T_j	150	$^\circ\text{C}$
T_{stg}	-55~150	$^\circ\text{C}$

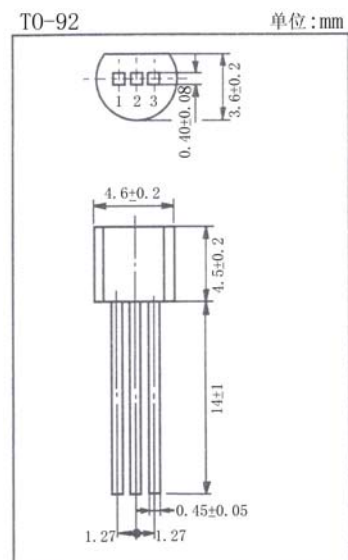

引脚: 1. E 2. C 3. B

电性能参数/Electrical characteristics ($T_a=25^\circ\text{C}$)

参数符号 Symbol	测试条件 Test condition	数值 Rating			单位 Unit
		最小值 Min	典型值 Typ	最大值 Max	
I_{CB0}	$V_{CB}=-60\text{V}$ $I_E=0$			-0.1	μA
I_{EB0}	$V_{EB}=-5.0\text{V}$ $I_C=0$			-0.1	μA
$h_{FE(1)}$	$V_{CE}=-1.0\text{V}$ $I_C=-50\text{mA}$	90		400	
$h_{FE(2)}$	$V_{CE}=-1.0\text{V}$ $I_C=-300\text{mA}$	30			
$V_{CE(sat)}$	$I_C=-300\text{mA}$ $I_B=-30\text{mA}$		-0.15	-0.60	V
$V_{BE(sat)}$	$I_C=-300\text{mA}$ $I_B=-30\text{mA}$		-0.85	-1.20	V
V_{BE}	$V_{CE}=-6.0\text{V}$ $I_C=-10\text{mA}$		-0.66	-0.70	V
f_T	$V_{CE}=-6.0\text{V}$ $I_C=-10\text{mA}$	50	100		MHz
C_{ob}	$V_{CB}=-6.0\text{V}$ $I_E=0$ $f=1.0\text{MHz}$		13	25	pF

$h_{FE(1)}$ 分档/ $h_{FE(1)}$ classifications: M:90~180 L:135~270 K:200~400

