



2SC1360 (3DA1360)

2SC1360A (3DA1360A)

硅 NPN 半导体三极管/SILICON NPN TRANSISTOR

用途:用于图像中频放大。

Purpose: Picture IF amplifier .

特点:特征频率高,集电极耗散功率大。

Features: High f_T , large P_C .

极限参数/Absolute maximum ratings ($T_a=25^\circ\text{C}$)

参数符号 Symbol	数值 Rating	单位 Unit
V_{CBO} 2SC1360 2SC1360A	50 60	V
V_{CEO} 2SC1360 2SC1360A	45 60	V
V_{EBO}	4.0	V
I_C	50	mA
P_C	1.0	W
T_j	150	$^\circ\text{C}$
T_{stg}	-55~150	$^\circ\text{C}$

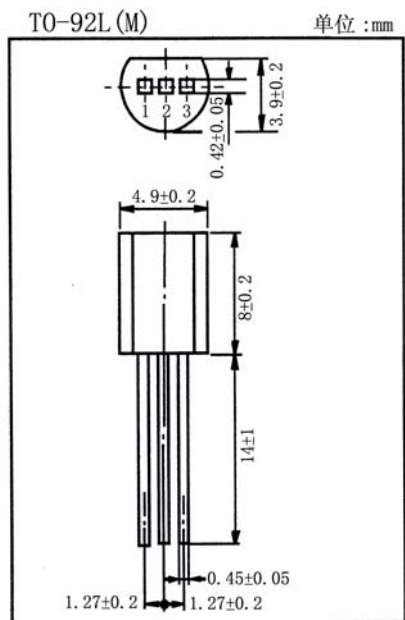

引脚: 1. E 2. C 3. B

电性能参数/Electrical characteristics ($T_a=25^\circ\text{C}$)

参数符号 Symbol	测试条件 Test condition	数值 Rating			单位 Unit
		最小值 Min	典型值 Typ	最大值 Max	
V_{CBO} 2SC1360 2SC1360A	$I_C=100\ \mu\text{A}$ $I_E=0$	50 60			V
V_{CEO} 2SC1360 2SC1360A	$I_C=3.0\text{mA}$ $I_B=0$	45 60			V
I_{CBO}	$V_{CB}=20\text{V}$ $I_E=0$			0.1	μA
h_{FE}	$V_{CE}=10\text{V}$ $I_C=10\text{mA}$	20		100	
$V_{CE(sat)}$	$I_C=20\text{mA}$ $I_B=2.0\text{mA}$			0.4	V
f_T	$V_{CE}=10\text{V}$ $I_C=10\text{mA}$ $f=100\text{MHz}$	300			MHz
G_{pe}	$V_{CB}=10\text{V}$ $I_E=-10\text{mA}$ $f=58\text{MHz}$	22		30	dB
C_{re}	$V_{CB}=10\text{V}$ $I_E=-1.0\text{mA}$ $f=10.7\text{MHz}$			1.5	pF



2SC1360 (3DA1360)
2SC1360A (3DA1360A)

