

用途:用于一般放大。

Purpose: General purpose amplifier.

极限参数/Absolute maximum ratings(Ta=25°C)

参数符号 Symbol	数值 Rating	单位 Unit
V _{CB0}	60	V
V _{CE0}	30	V
V _{EB0}	5.0	V
I _C	600	mA
P _C	625	mW
T _j	150	°C
T _{stg}	-55~150	°C

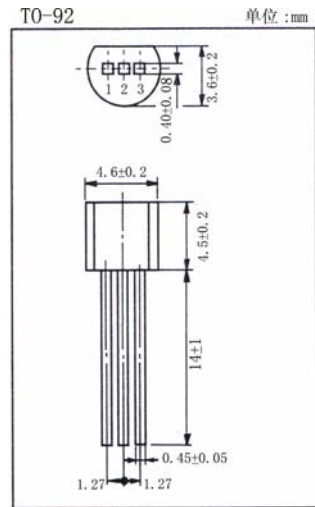

引脚: 1. E 2. B 3. C

电性能参数/Electrical characteristics(Ta=25°C)

参数符号 Symbol	测试条件 Test condition		数值 Rating			单位 Unit
			最小值 Min	典型值 Typ	最大值 Max	
V _{CB0}	I _C =10 μ A	I _E =0	60			V
V _{CE0}	I _E =10mA	I _B =0	30			V
V _{EB0}	I _E =10 μ A	I _C =0	5.0			V
I _{CB0}	V _{CB} =50V	I _E =0			0.01	μ A
I _{EB0}	V _{EB} =5.0V	I _C =0			0.1	μ A
h _{FE}	V _{CE} =10V	I _C =150mA	100		300	
V _{CE(sat) (1)}	I _C =150mA	I _B =15mA			0.4	V
V _{CE(sat) (2)}	I _C =500mA	I _B =50mA			1.6	V
V _{BE(sat) (1)}	I _C =150mA	I _B =15mA			1.3	V
V _{BE(sat) (2)}	I _C =500mA	I _B =50mA			2.6	V
f _T	V _{CE} =20V I _C =20mA	f=100MHz	250			MHz
C _{ob}	V _{CB} =10V I _E =0	f=1.0MHz			8.0	pF
T _{on}	V _{CC} =30V I _C =150mA	V _{BE} =0.5V I _{B1} =15mA			35	ns
T _{off}	V _{CC} =30V I _C =150mA	I _{B1} =I _{B2} =15mA			285	ns



2N2222 (3DG2222)

