

用途:用于音频功率放大。/Purpose: Audio frequency power amplifier applications.

特点:与 2SA966 (3CG966) 互补可得 3W 输出。/Features: Complementary to 2SA966 (3CG966)

And 3 watts output applications.

极限参数/Absolute maximum ratings (Ta=25°C)

参数符号 Symbol	数值 Rating	单位 Unit
V _{CBO}	30	V
V _{CEO}	30	V
V _{EB0}	5.0	V
I _C	1.5	A
I _E	-1.5	A
P _C	900	mW
T _j	150	°C
T _{stg}	-55~150	°C

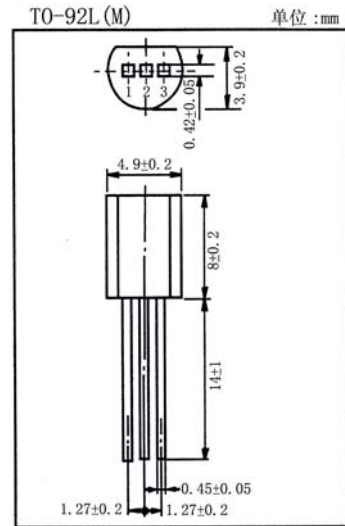

引脚: 1. E 2. C 3. B

电性能参数/Electrical characteristics (Ta=25°C)

参数符号 Symbol	测试条件 Test condition		数值 Rating			单位 Unit
			最小值 Min	典型值 Typ	最大值 Max	
V _{CEO}	I _C =10mA	I _B =0	30			V
V _{EB0}	I _E =1.0mA	I _C =0	5.0			V
I _{CBO}	V _{CB} =30V	I _E =0			0.1	μA
I _{EB0}	V _{EB} =5.0V	I _C =0			0.1	μA
h _{FE}	V _{CE} =2.0V	I _C =500mA	100		320	
V _{CE(sat)}	I _C =1.5A	I _B =0.03A			2.0	V
V _{BE}	V _{CE} =2.0V	I _C =500mA			1.0	V
f _T	V _{CE} =2.0V	I _C =500mA		120		MHz
C _{ob}	V _{CB} =10V	I _E =0			30	pF

h_{FE} 分档/h_{FE} classifications: 0:100~200 Y:160~320



2SC2236 (3DG2236)

