

Features

- Glass Passivated Die Construction
- 3000W Peak Pulse Power Dissipation
- 5.0V – 440V Standoff Voltage
- Uni- and Bi-Directional Versions Available
- Excellent Clamping Voltage
- Typical Response Time < 1nS
- Plastic Case Material has UL Flammability Classification Rating 94V-0

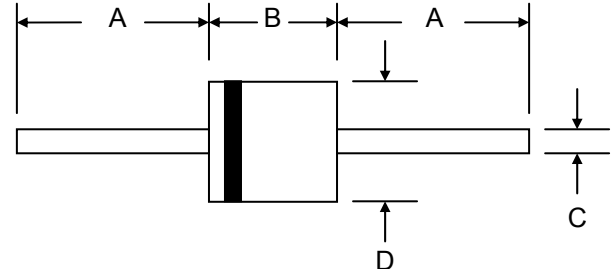

Mechanical Data

- Case: P-600, Molded Plastic
- Terminals: Plated Leads Solderable per MIL-STD-202, Method 208
- Polarity: Cathode Band Except Bi-Directional
- Weight: 2.10 grams (approx.)
- Mounting Position: Any
- Marking: Type Number
- **Lead Free: For RoHS / Lead Free Version, Add “-LF” Suffix to Part Number, See Page 6**

P-600		
Dim	Min	Max
A	25.4	—
B	8.60	9.10
C	1.20	1.30
D	8.60	9.10
All Dimensions in mm		

Maximum Ratings and Electrical Characteristics @ $T_A=25^\circ\text{C}$ unless otherwise specified

Characteristic	Symbol	Value	Unit
Peak Pulse Power Dissipation on 10/1000 μS Waveform (Note 1, 2, 5)	PPPM	3000	W
Peak Pulse Current on 10/1000 μS Waveform (Note 1)	IPPM	See Table 1	A
Peak Forward Surge Current (Note 2, 3)	IFSM	300	A
Maximum Instantaneous Forward Voltage at 100A (Note 3, 4)	V_F	3.5 / 5.0	V
Power Dissipation at $T_L = 75^\circ\text{C}$ (Note 2)	P_D	7.0	W
Typical Thermal Resistance, Junction to Ambient (Note 2)	R_{JA}	40	$^\circ\text{C}/\text{W}$
Typical Thermal Resistance, Junction to Lead (Note 2)	R_{JL}	8.0	$^\circ\text{C}/\text{W}$
Operating and Storage Temperature Range	T_J, T_{STG}	-55 to +150	$^\circ\text{C}$

- Note: 1. Non-repetitive current pulse per Figure 5 and derated above $T_A = 25^\circ\text{C}$ per Figure 1.
 2. Mounted on 20 x 20 x 1.0mm thick copper pads to each terminal that maintained at a distance of 9.5mm from the case.
 3. Measured on 8.3ms single half sine-wave, duty cycle = 4 pulses per minute maximum. For uni-directional devices only.
 4. $V_F < 3.5\text{V}$ for $V_{BR} \leq 200\text{V}$ and $V_F < 5.0\text{V}$ for $V_{BR} \geq 201\text{V}$.
 5. Peak pulse power waveform is 10/1000 μS .

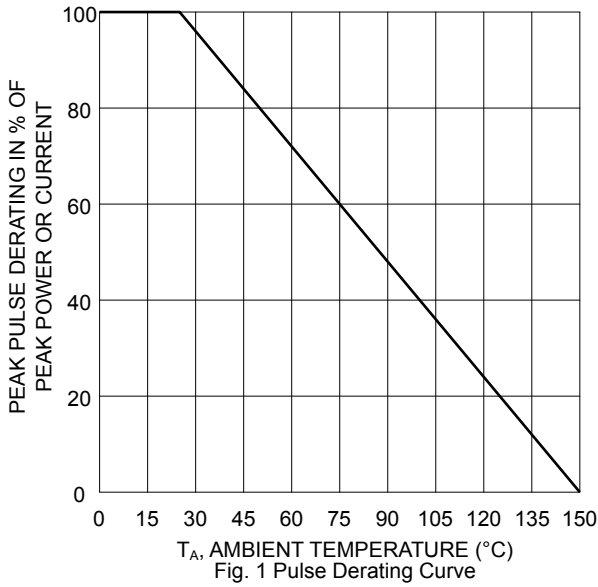

Fig. 1 Pulse Derating Curve

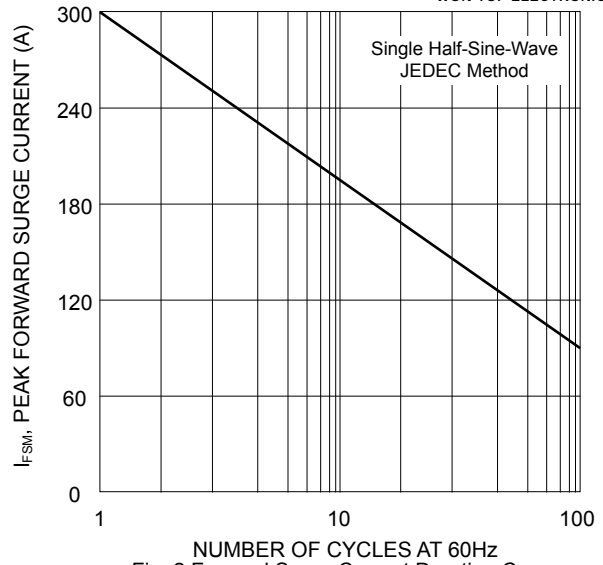

Fig. 2 Forward Surge Current Derating Curve

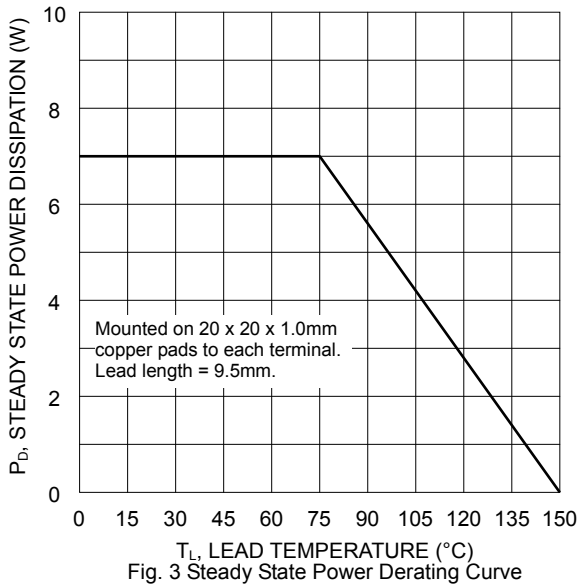

Fig. 3 Steady State Power Derating Curve

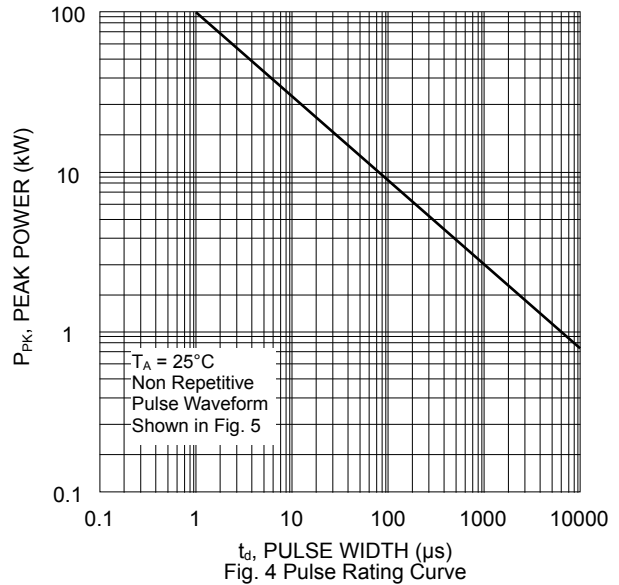

Fig. 4 Pulse Rating Curve

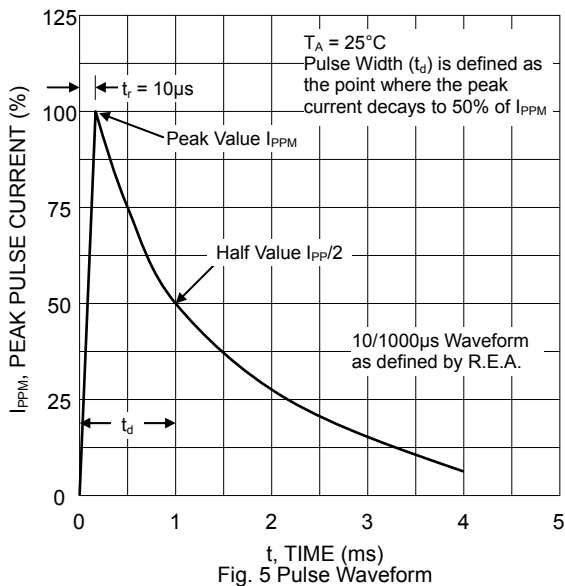

Fig. 5 Pulse Waveform

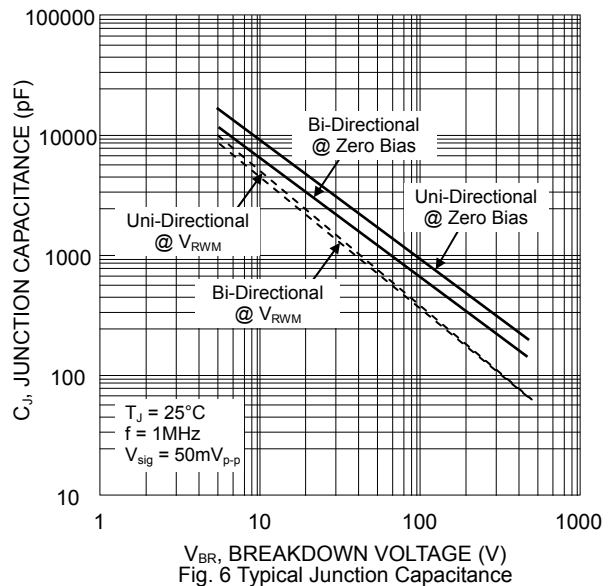

Fig. 6 Typical Junction Capacitance

Electrical Characteristics (@T_A=25°C unless otherwise specified) Table 1

Uni-Directional Part No.	Bi-Directional Part No.	Reverse Stand-Off Voltage V _{RWM} (V)	Breakdown Voltage V _{BR} (V) @I _T		Test Current I _T (mA)	Maximum Clamping Voltage @I _{PP} V _C (V)	Peak Pulse Current I _{PP} (A)	Reverse Leakage* @V _{RWM} I _R (μA)
			Min.	Max.				
3KP5.0	3KP5.0C	5.0	6.40	7.30	50	9.6	312.50	5000
3KP5.0A	3KP5.0CA	5.0	6.40	7.00	50	9.2	326.09	5000
3KP6.0	3KP6.0C	6.0	6.67	8.15	50	11.4	263.16	5000
3KP6.0A	3KP6.0CA	6.0	6.67	7.37	50	10.3	291.26	5000
3KP6.5	3KP6.5C	6.5	7.22	8.82	50	12.3	243.90	2000
3KP6.5A	3KP6.5CA	6.5	7.22	7.98	50	11.2	267.86	2000
3KP7.0	3KP7.0C	7.0	7.78	9.51	50	13.3	225.56	1000
3KP7.0A	3KP7.0CA	7.0	7.78	8.60	50	12.0	250.00	1000
3KP7.5	3KP7.5C	7.5	8.33	10.20	5	14.3	209.79	250
3KP7.5A	3KP7.5CA	7.5	8.33	9.21	5	12.9	232.56	250
3KP8.0	3KP8.0C	8.0	8.89	10.90	5	15.0	200.00	150
3KP8.0A	3KP8.0CA	8.0	8.89	9.83	5	13.6	220.59	150
3KP8.5	3KP8.5C	8.5	9.44	11.50	5	15.9	188.68	50
3KP8.5A	3KP8.5CA	8.5	9.44	10.40	5	14.4	208.33	50
3KP9.0	3KP9.0C	9.0	10.00	12.20	5	16.9	177.51	20
3KP9.0A	3KP9.0CA	9.0	10.00	11.10	5	15.4	194.81	20
3KP10	3KP10C	10.0	11.10	13.60	5	18.8	159.57	15
3KP10A	3KP10CA	10.0	11.10	12.30	5	17.0	176.47	15
3KP11	3KP11C	11.0	12.20	14.90	5	20.1	149.25	2
3KP11A	3KP11CA	11.0	12.20	13.50	5	18.2	164.84	2
3KP12	3KP12C	12.0	13.30	16.30	5	22.0	136.36	2
3KP12A	3KP12CA	12.0	13.30	14.70	5	19.9	150.75	2
3KP13	3KP13C	13.0	14.40	17.60	5	23.8	126.05	2
3KP13A	3KP13CA	13.0	14.40	15.90	5	21.5	139.53	2
3KP14	3KP14C	14.0	15.60	19.10	5	25.8	116.28	2
3KP14A	3KP14CA	14.0	15.60	17.20	5	23.2	129.31	2
3KP15	3KP15C	15.0	16.70	20.40	5	26.9	111.52	2
3KP15A	3KP15CA	15.0	16.70	18.50	5	24.4	122.95	2
3KP16	3KP16C	16.0	17.80	21.80	5	28.8	104.17	2
3KP16A	3KP16CA	16.0	17.80	19.70	5	26.0	115.38	2
3KP17	3KP17C	17.0	18.90	23.10	5	30.5	98.36	2
3KP17A	3KP17CA	17.0	18.90	20.90	5	27.6	108.70	2
3KP18	3KP18C	18.0	20.00	24.40	5	32.2	93.17	2
3KP18A	3KP18CA	18.0	20.00	22.10	5	29.2	102.74	2
3KP20	3KP20C	20.0	22.20	27.10	5	35.8	83.80	2
3KP20A	3KP20CA	20.0	22.20	24.50	5	32.4	92.59	2
3KP22	3KP22C	22.0	24.40	29.80	5	39.4	76.14	2
3KP22A	3KP22CA	22.0	24.40	26.90	5	35.5	84.51	2
3KP24	3KP24C	24.0	26.70	32.60	5	43.0	69.77	2
3KP24A	3KP24CA	24.0	26.70	29.50	5	38.9	77.12	2
3KP26	3KP26C	26.0	28.90	35.30	5	46.6	64.38	2
3KP26A	3KP26CA	26.0	28.90	31.90	5	42.1	71.26	2
3KP28	3KP28C	28.0	31.10	38.00	5	50.0	60.00	2
3KP28A	3KP28CA	28.0	31.10	34.40	5	45.4	66.08	2
3KP30	3KP30C	30.0	33.30	40.70	5	53.5	56.07	2
3KP30A	3KP30CA	30.0	33.30	36.80	5	48.4	61.98	2
3KP33	3KP33C	33.0	36.70	44.90	5	59.0	50.85	2
3KP33A	3KP33CA	33.0	36.70	40.60	5	53.3	56.29	2
3KP36	3KP36C	36.0	40.00	48.90	5	64.3	46.66	2
3KP36A	3KP36CA	36.0	40.00	44.20	5	58.1	51.64	2
3KP40	3KP40C	40.0	44.40	54.30	5	71.4	42.02	2
3KP40A	3KP40CA	40.0	44.40	49.10	5	64.5	46.51	2
3KP43	3KP43C	43.0	47.80	58.40	5	76.7	39.11	2
3KP43A	3KP43CA	43.0	47.80	52.80	5	69.4	43.23	2
3KP45	3KP45C	45.0	50.00	61.10	5	80.3	37.36	2
3KP45A	3KP45CA	45.0	50.00	55.30	5	72.7	41.27	2
3KP48	3KP48C	48.0	53.30	65.10	5	85.5	35.09	2
3KP48A	3KP48CA	48.0	53.30	58.90	5	77.4	38.76	2
3KP51	3KP51C	51.0	56.70	69.30	5	91.1	32.93	2
3KP51A	3KP51CA	51.0	56.70	62.70	5	82.4	36.41	2
3KP54	3KP54C	54.0	60.00	73.30	5	96.3	31.15	2
3KP54A	3KP54CA	54.0	60.00	66.30	5	87.1	34.44	2
3KP58	3KP58C	58.0	64.40	78.70	5	103.0	29.13	2
3KP58A	3KP58CA	58.0	64.40	71.20	5	93.6	32.05	2

*For bi-directional devices V_{RWM} ≤ 10V, the I_R limit is double.

Electrical Characteristics (@T_A=25°C unless otherwise specified) Table 1 (Cont'd)

Uni-Directional Part No.	Bi-Directional Part No.	Reverse Stand-Off Voltage V _{RWM} (V)	Breakdown Voltage V _{BR} (V) @I _T		Test Current I _T (mA)	Maximum Clamping Voltage @I _{PP} V _C (V)	Peak Pulse Current I _{PP} (A)	Reverse Leakage* @V _{RWM} I _R (μA)
			Min.	Max.				
3KP60	3KP60C	60.0	66.70	81.50	5	107.0	28.04	2
3KP60A	3KP60CA	60.0	66.70	73.70	5	96.8	30.99	2
3KP64	3KP64C	64.0	71.10	86.90	5	114.0	26.32	2
3KP64A	3KP64CA	64.0	71.10	78.60	5	103.0	29.13	2
3KP70	3KP70C	70.0	77.80	95.10	5	125.0	24.00	2
3KP70A	3KP70CA	70.0	77.80	86.00	5	113.0	26.55	2
3KP75	3KP75C	75.0	83.30	102.00	5	134.0	22.39	2
3KP75A	3KP75CA	75.0	83.30	92.10	5	121.0	24.79	2
3KP78	3KP78C	78.0	86.70	106.00	5	139.0	21.58	2
3KP78A	3KP78CA	78.0	86.70	95.80	5	126.0	23.81	2
3KP85	3KP85C	85.0	94.40	115.00	5	151.0	19.87	2
3KP85A	3KP85CA	85.0	94.40	104.00	5	137.0	21.90	2
3KP90	3KP90C	90.0	100.00	122.00	5	160.0	18.75	2
3KP90A	3KP90CA	90.0	100.00	111.00	5	146.0	20.55	2
3KP100	3KP100C	100.0	111.00	136.00	5	179.0	16.76	2
3KP100A	3KP100CA	100.0	111.00	123.00	5	162.0	18.52	2
3KP110	3KP110C	110.0	122.00	149.00	5	196.0	15.31	2
3KP110A	3KP110CA	110.0	122.00	135.00	5	177.0	16.95	2
3KP120	3KP120C	120.0	133.00	163.00	5	214.0	14.02	2
3KP120A	3KP120CA	120.0	133.00	147.00	5	193.0	15.54	2
3KP130	3KP130C	130.0	144.00	176.00	5	231.0	12.99	2
3KP130A	3KP130CA	130.0	144.00	159.00	5	209.0	14.35	2
3KP150	3KP150C	150.0	167.00	204.00	5	268.0	11.19	2
3KP150A	3KP150CA	150.0	167.00	185.00	5	243.0	12.35	2
3KP160	3KP160C	160.0	178.00	218.00	5	287.0	10.45	2
3KP160A	3KP160CA	160.0	178.00	197.00	5	259.0	11.58	2
3KP170	3KP170C	170.0	189.00	231.00	5	304.0	9.87	2
3KP170A	3KP170CA	170.0	189.00	209.00	5	275.0	10.91	2
3KP180	3KP180C	180.0	200.00	244.80	5	322.2	9.31	2
3KP180A	3KP180CA	180.0	200.00	220.00	5	291.6	10.29	2
3KP190	3KP190C	190.0	211.00	258.40	5	340.1	8.82	2
3KP190A	3KP190CA	190.0	211.00	232.00	5	307.8	9.75	2
3KP200A	3KP200CA	200.0	224.00	247.00	5	324.0	9.26	2
3KP210A	3KP210CA	210.0	233.00	258.00	5	349.5	8.58	2
3KP220A	3KP220CA	220.0	246.00	272.00	5	356.0	8.43	2
3KP250A	3KP250CA	250.0	279.00	309.00	5	405.0	7.41	2
3KP300A	3KP300CA	300.0	335.00	371.00	5	486.0	6.17	2
3KP350A	3KP350CA	350.0	391.00	432.00	5	567.0	5.29	2
3KP400A	3KP400CA	400.0	447.00	494.00	5	648.0	4.63	2
3KP440A	3KP440CA	440.0	492.00	543.00	5	713.0	4.21	2

MARKING INFORMATION

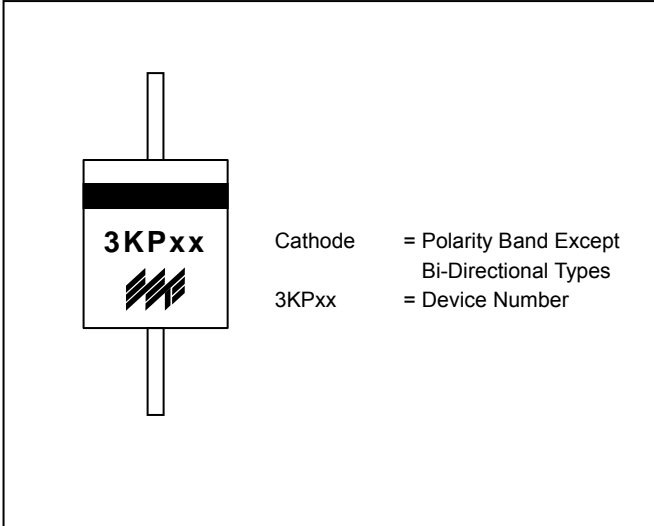

TAPING SPECIFICATIONS

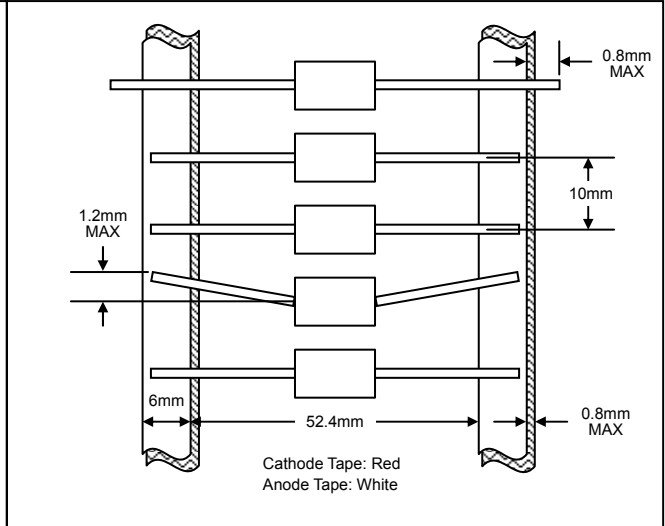

PACKAGING INFORMATION

TAPE & REEL

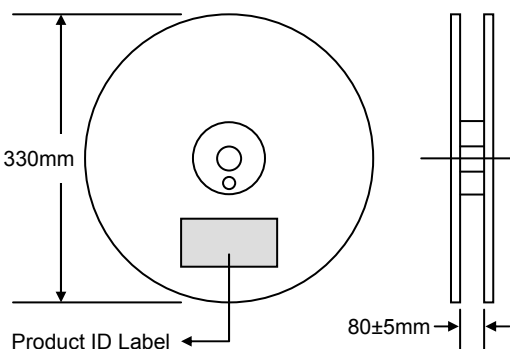

330mm

Product ID Label

80±5mm

BULK

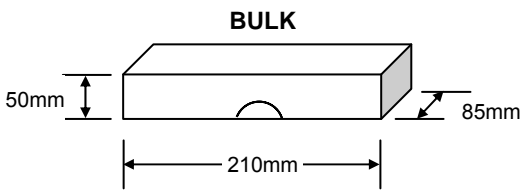

50mm

210mm

85mm

Packaging	Reel Diameter / Box Size (mm)	Quantity (PCS)	Carton Size (mm)	Quantity (PCS)	Approx. Gross Weight (KG)
TAPE & REEL	330	800	370 x 370 x 420	4,000	12.0
BULK	210 x 85 x 50	250	500 x 255 x 275	7,000	17.0

Note: 1. Paper reel, white or gray color. Core material: plastic or metal.
2. Components are packed in accordance with EIA standard RS-296-E.

ORDERING INFORMATION

Product No.	Package Type	Shipping Quantity
3KPxx-T3	P-600	800/Tape & Reel
3KPxx	P-600	250 Units/Box

1. Products listed in **bold** are WTE **Preferred** Devices.
2. Shipping quantity given is for minimum packing quantity only. For minimum order quantity, please consult the Sales Department.
3. **To order RoHS / Lead Free version (with Lead Free finish), add "-LF" suffix to part number above. For example, 3KP5.0-T3-LF.**

WON-TOP ELECTRONICS and  are registered trademarks of Won-Top Electronics Co., Ltd (WTE). WTE has checked all information carefully and believes it to be correct and accurate. However, WTE cannot assume any responsibility for inaccuracies. Furthermore, this information does not give the purchaser of semiconductor devices any license under patent rights to manufacturer. WTE reserves the right to change any or all information herein without further notice.

WARNING: DO NOT USE IN LIFE SUPPORT EQUIPMENT. WTE power semiconductor products are not authorized for use as critical components in life support devices or systems without the express written approval.

Won-Top Electronics Co., Ltd.
No. 44 Yu Kang North 3rd Road,
Chine Chen Dist., Kaohsiung 806, Taiwan
Phone: 886-7-822-5408 or 886-7-822-5410
Fax: 886-7-822-5417
Email: sales@wontop.com
Internet: http://www.wontop.com

We power your everyday.