



STB3N62K3, STD3N62K3, STF3N62K3 STP3N62K3, STU3N62K3

N-channel 620 V, 2.2 Ω , 2.7 A SuperMESH3™ Power MOSFET
D²PAK, DPAK, TO-220FP, TO-220, IPAK

Features

Type	V _{DSS}	R _{DS(on)} max	I _D	P _D
STB3N62K3	620 V	< 2.5 Ω	2.7 A	45 W
STD3N62K3	620 V	< 2.5 Ω	2.7 A	45 W
STF3N62K3	620 V	< 2.5 Ω	2.7 A ⁽¹⁾	20 W
STP3N62K3	620 V	< 2.5 Ω	2.7 A	45 W
STU3N62K3	620 V	< 2.5 Ω	2.7 A	45 W

1. Limited by package

- 100% avalanche tested
- Extremely high dv/dt capability
- Very low intrinsic capacitances
- Improved diode reverse recovery characteristics
- Zener-protected

Application

- Switching applications

Description

The new SuperMESH3™ series is obtained through the combination of a further fine tuning of ST's well established strip-based PowerMESH™ layout with a new optimization of the vertical structure. In addition to reducing on-resistance significantly versus previous generation, special attention has been taken to ensure a very good dv/dt capability and higher margin in breakdown voltage for the most demanding application.

Table 1. Device summary

Order codes	Marking	Package	Packaging
STB3N62K3	3N62K3	D ² PAK	Tape and reel
STD3N62K3	3N62K3	DPAK	Tape and reel
STF3N62K3	3N62K3	TO-220FP	Tube
STP3N62K3	3N62K3	TO-220	Tube
STU3N62K3	3N62K3	IPAK	Tube

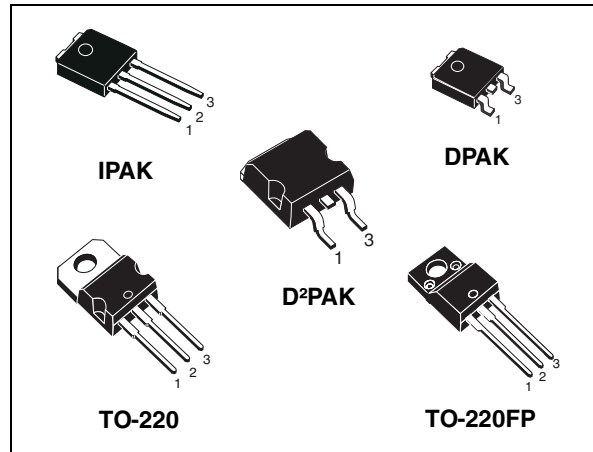
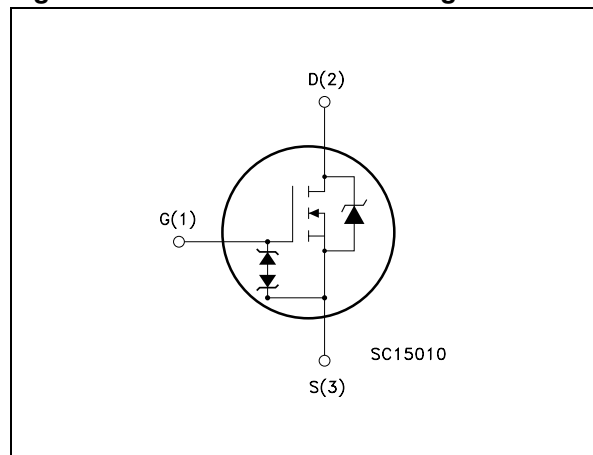

Figure 1. Internal schematic diagram



Contents

1	Electrical ratings	3
2	Electrical characteristics	5
	2.1 Electrical characteristics (curves)	7
3	Test circuits	10
4	Package mechanical data	11
5	Package mechanical data	17
6	Revision history	19

1 Electrical ratings

Table 2. Absolute maximum ratings

Symbol	Parameter	Value			Unit
		TO-220 D ² PAK	DPAK IPAK	TO-220FP	
V _{DS}	Drain-source voltage (V _{GS} = 0)	620			V
V _{GS}	Gate- source voltage	± 30			V
I _D	Drain current (continuous) at T _C = 25 °C	2.7		2.7 ⁽¹⁾	A
I _D	Drain current (continuous) at T _C = 100 °C	1.7		1.7 ⁽¹⁾	A
I _{DM} ⁽²⁾	Drain current (pulsed)	10.8		10.8 ⁽¹⁾	A
P _{TOT}	Total dissipation at T _C = 25 °C	45		20	W
	Derating factor	0.36		0.16	W/°C
V _{ESD(G-S)}	Gate source ESD (HBM-C = 100 pF, R = 1.5 kΩ)	2500			V
dv/dt ⁽³⁾	Peak diode recovery voltage slope	9			V/ns
V _{ISO}	Insulation withstand voltage (RMS) from all three leads to external heat sink (t = 1 s; T _C = 25 °C)	--		2500	V
T _{stg}	Storage temperature	-55 to 150			°C
T _j	Max. operating junction temperature	150			°C

- Limited by package
- Pulse width limited by safe operating area
- I_{SD} ≤ 2.7 A, di/dt ≤ 200 A/μs, V_{DD} = 80% V_{(BR)DSS}

Table 3. Thermal data

Symbol	Parameter	TO-220	D ² P AK	DPAK	IPAK	TO-220FP	Unit
R _{thj-case}	Thermal resistance junction-case max	2.78				6.25	°C/W
R _{thj-pcb}	Thermal resistance junction-pcb max	--	50		--	--	°C/W
R _{thj-amb}	Thermal resistance junction-amb max	62.5		100		62.5	°C/W
T _l	Maximum lead temperature for soldering purpose	300					°C

Table 4. Avalanche characteristics

Symbol	Parameter	Max value	Unit
I_{AR}	Avalanche current, repetitive or not-repetitive (pulse width limited by T_j max)	2.7	A
E_{AS}	Single pulse avalanche energy (starting $T_j = 25\text{ °C}$, $I_D = I_{AR}$, $V_{DD} = 50\text{ V}$)	100	mJ

2 Electrical characteristics

($T_C = 25\text{ °C}$ unless otherwise specified)

Table 5. On /off states

Symbol	Parameter	Test conditions	Min.	Typ.	Max.	Unit
$V_{(BR)DSS}$	Drain-source breakdown voltage	$I_D = 1\text{ mA}, V_{GS} = 0$	620			V
I_{DSS}	Zero gate voltage drain current ($V_{GS} = 0$)	$V_{DS} = \text{Max rating}$ $V_{DS} = \text{Max rating}, T_C = 125\text{ °C}$			1 50	μA μA
I_{GSS}	Gate-body leakage current ($V_{DS} = 0$)	$V_{GS} = \pm 20\text{ V}$			± 10	μA
$V_{GS(th)}$	Gate threshold voltage	$V_{DS} = V_{GS}, I_D = 50\text{ }\mu\text{A}$	3	3.75	4.5	V
$R_{DS(on)}$	Static drain-source on resistance	$V_{GS} = 10\text{ V}, I_D = 1.4\text{ A}$		2.2	2.5	Ω

Table 6. Dynamic

Symbol	Parameter	Test conditions	Min.	Typ.	Max.	Unit
$g_{fs} (1)$	Forward transconductance	$V_{DS} = 15\text{ V}, I_D = 1.4\text{ A}$	-	2.1	-	S
C_{iss} C_{oss} C_{rss}	Input capacitance Output capacitance Reverse transfer capacitance	$V_{DS} = 25\text{ V}, f = 1\text{ MHz}, V_{GS} = 0$	-	385 55 6	-	pF pF pF
$C_{OSS\ eq}^{(1)}$	Equivalent output capacitance	$V_{GS} = 0, V_{DS} = 0\text{ to }496\text{ V}$	-	32.3	-	pF
R_G	Intrinsic gate resistance	$f = 1\text{ MHz}$ open drain	-	10	-	Ω
Q_g Q_{gs} Q_{gd}	Total gate charge Gate-source charge Gate-drain charge	$V_{DD} = 496\text{ V}, I_D = 2.7\text{ A},$ $V_{GS} = 10\text{ V}$ (see Figure 17)	-	13 2.5 7.5	-	nC nC nC

1. $C_{OSS\ eq}$ is defined as a constant equivalent capacitance giving the same charging time as C_{OSS} when V_{DS} increases from 0 to 80% V_{DSS}

Table 7. Switching times

Symbol	Parameter	Test conditions	Min.	Typ.	Max	Unit
$t_{d(on)}$ t_r $t_{d(off)}$ t_f	Turn-on delay time Rise time Turn-off-delay time Fall time	$V_{DD} = 310\text{ V}, I_D = 1.7\text{ A},$ $R_G = 4.7\text{ }\Omega, V_{GS} = 10\text{ V}$ (see Figure 16)	-	9 6.8 22 15.6	-	ns ns ns ns

Table 8. Source drain diode

Symbol	Parameter	Test conditions	Min.	Typ.	Max.	Unit
I_{SD}	Source-drain current		-		2.7	A
$I_{SDM}^{(1)}$	Source-drain current (pulsed)		-		10.8	A
$V_{SD}^{(2)}$	Forward on voltage	$I_{SD} = 2.7 \text{ A}, V_{GS} = 0$	-		1.6	V
t_{rr}	Reverse recovery time	$I_{SD} = 2.7 \text{ A}, di/dt = 100 \text{ A}/\mu\text{s}$ $V_{DD} = 60 \text{ V}$ (see Figure 21)	-	190		ns
Q_{rr}	Reverse recovery charge			825		nC
I_{RRM}	Reverse recovery current			9		A
t_{rr}	Reverse recovery time	$I_{SD} = 2.7 \text{ A}, di/dt = 100 \text{ A}/\mu\text{s}$ $V_{DD} = 60 \text{ V}, T_j = 150 \text{ }^\circ\text{C}$ (see Figure 21)	-	255		ns
Q_{rr}	Reverse recovery charge			1100		nC
I_{RRM}	Reverse recovery current			10		A

1. Pulse width limited by safe operating area
2. Pulsed: Pulse duration = 300 μs , duty cycle 1.5%

Table 9. Gate-source Zener diode

Symbol	Parameter	Test conditions	Min	Typ	Max	Unit
$BV_{GSO}^{(1)}$	Gate-source breakdown voltage	$I_{gs} = \pm 1 \text{ mA}$ (open drain)	30			V

1. The built-in back-to-back Zener diodes have specifically been designed to enhance not only the device's ESD capability, but also to make them safely absorb possible voltage transients that may occasionally be applied from gate to source. In this respect the Zener voltage is appropriate to achieve an efficient and cost-effective intervention to protect the device's integrity. These integrated Zener diodes thus avoid the usage of external components

2.1 Electrical characteristics (curves)

Figure 2. Safe operating area for TO-220, IPAK, DPAK, D²PAK

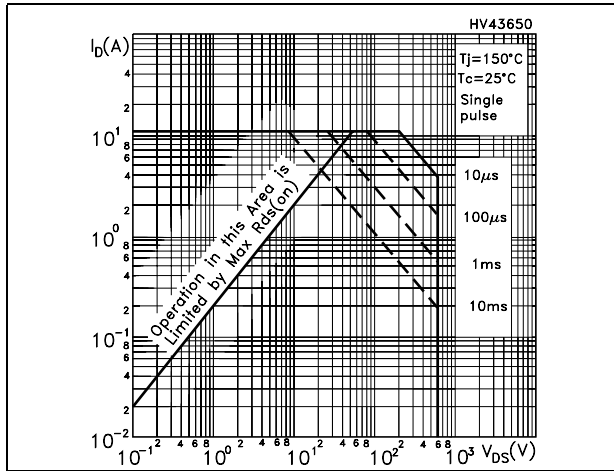

Figure 3. Thermal impedance for TO-220, IPAK, DPAK, D²PAK

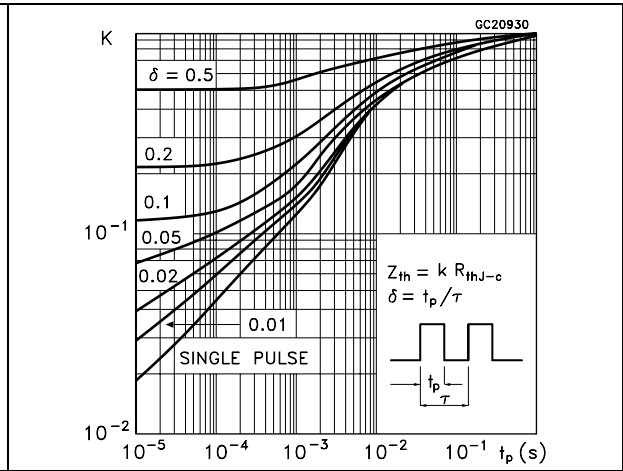

Figure 4. Safe operating area for TO-220FP

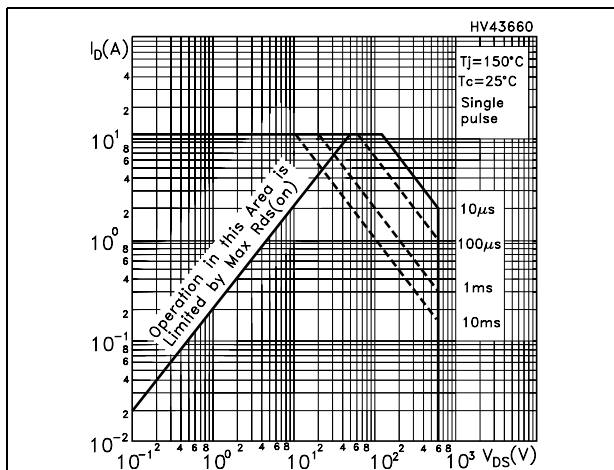

Figure 5. Thermal impedance for TO-220FP

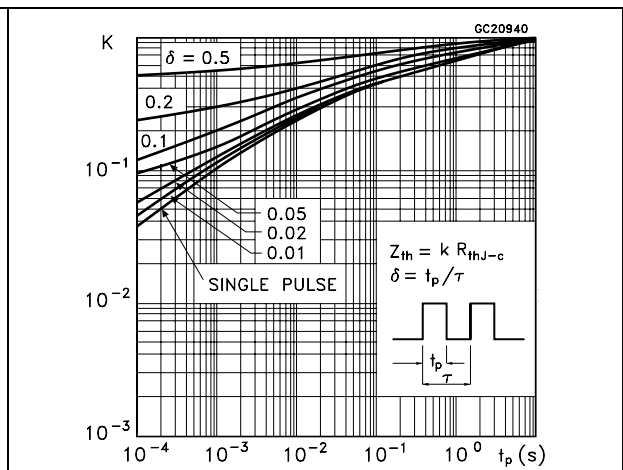

Figure 6. Output characteristics

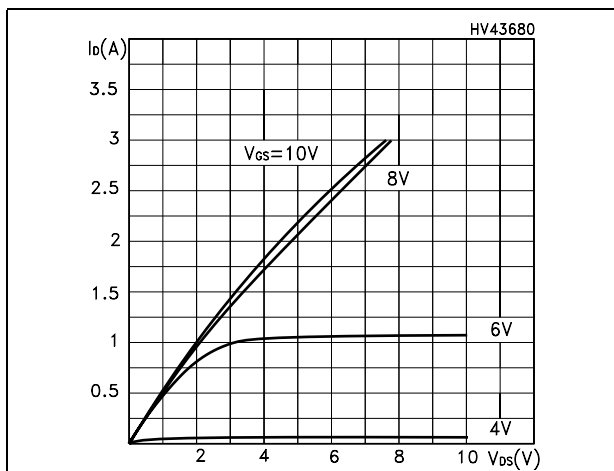

Figure 7. Transfer characteristics

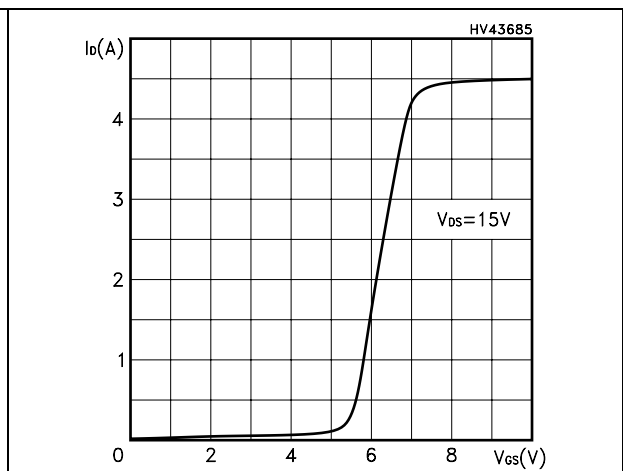

Figure 8. Normalized BV_{DSS} vs temperature Figure 9. Static drain-source on resistance

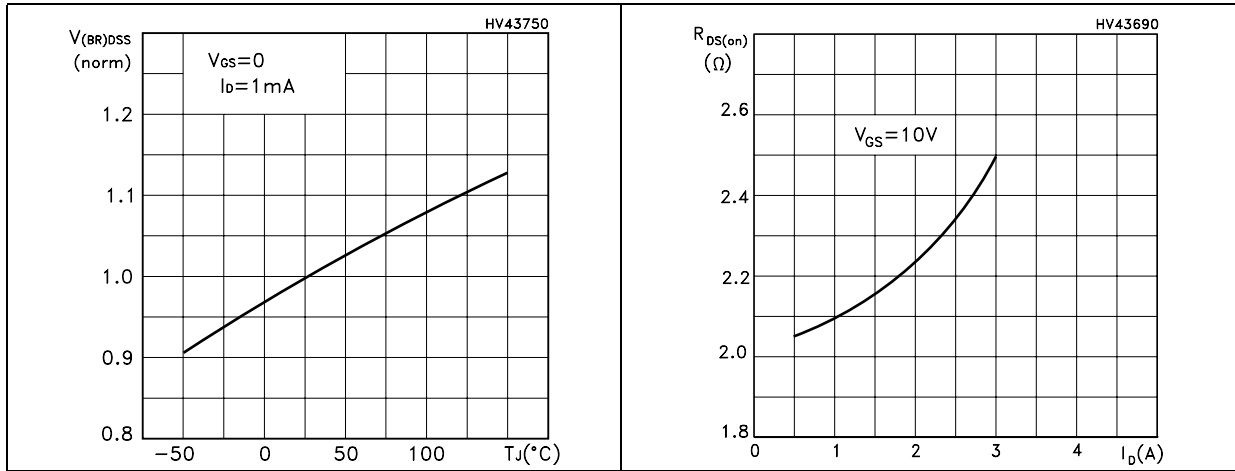

Figure 10. Gate charge vs gate-source voltage Figure 11. Capacitance variations

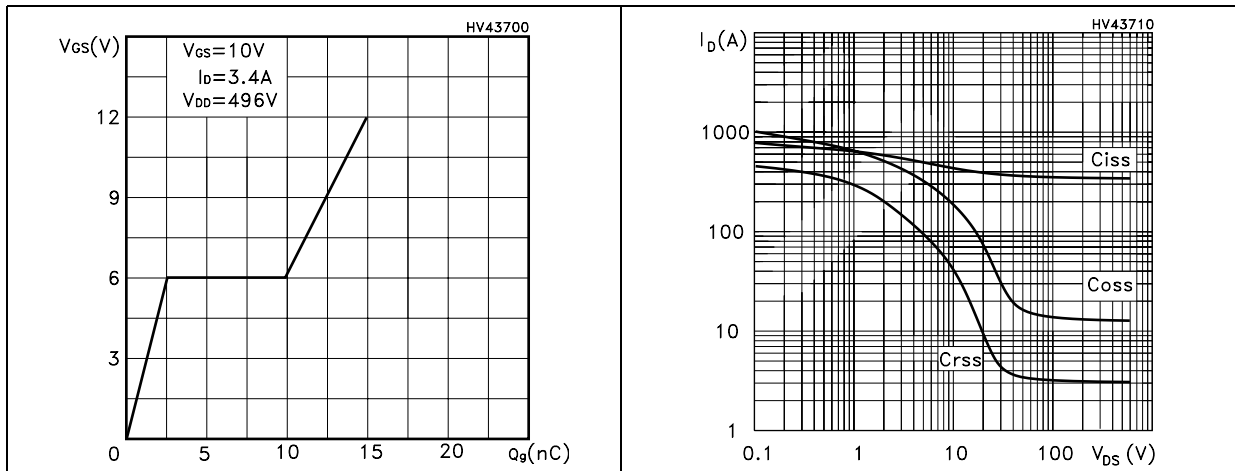

Figure 12. Normalized gate threshold voltage vs temperature Figure 13. Normalized on resistance vs temperature

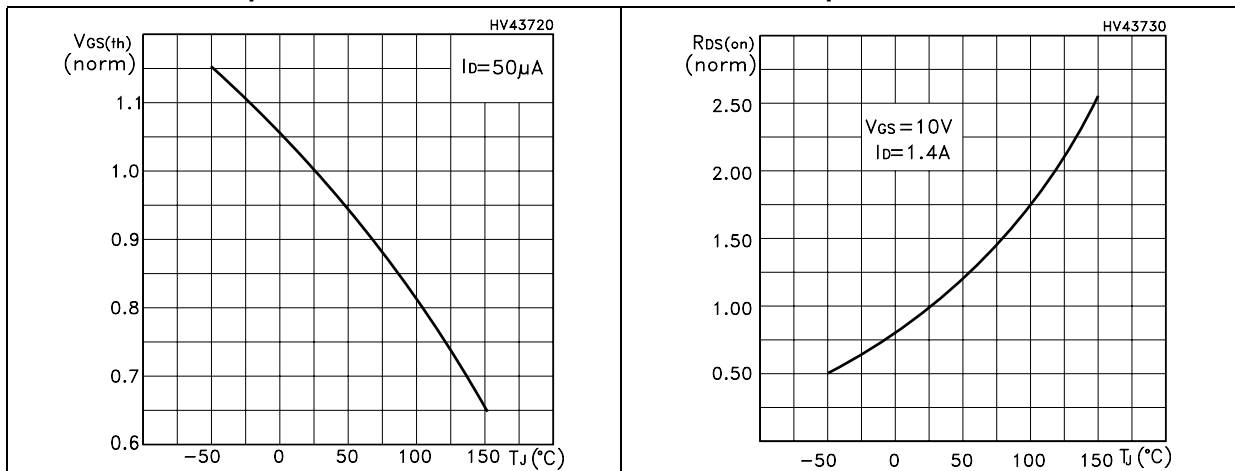

Figure 14. Source-drain diode forward characteristics

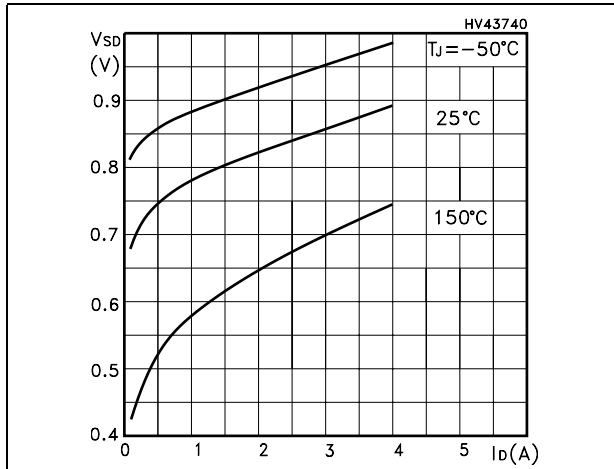
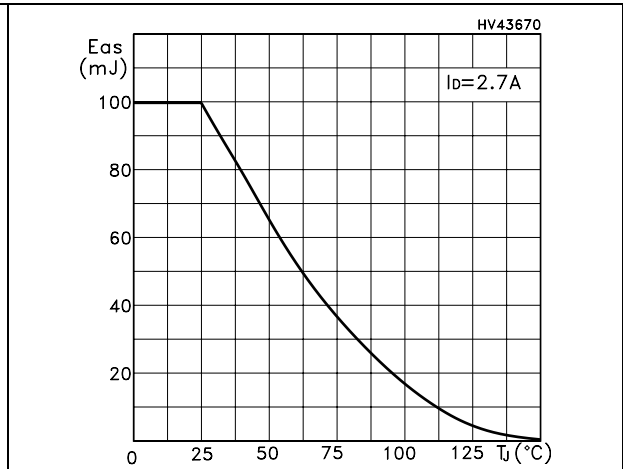

Figure 15. Maximum avalanche energy vs temperature



3 Test circuits

Figure 16. Switching times test circuit for resistive load

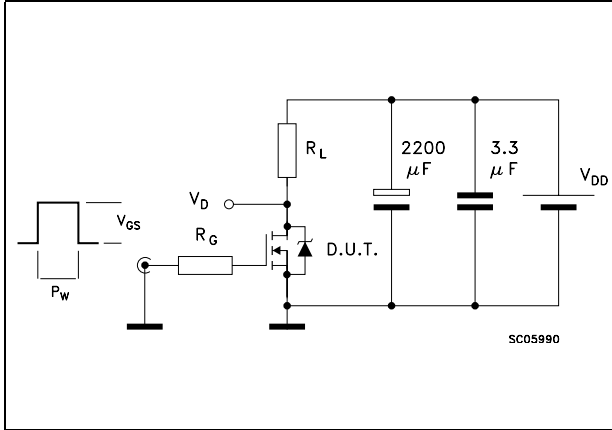

Figure 17. Gate charge test circuit

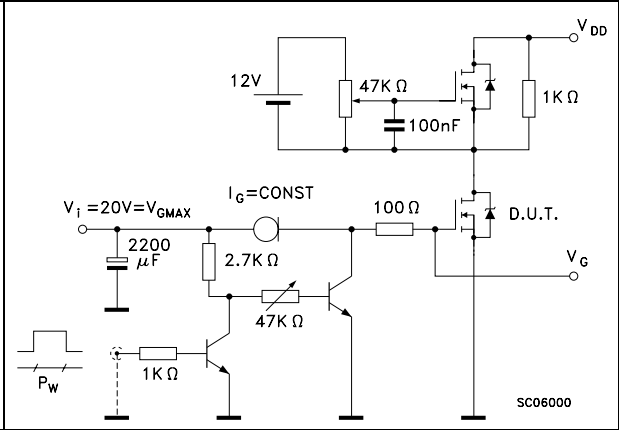

Figure 18. Test circuit for inductive load switching and diode recovery times

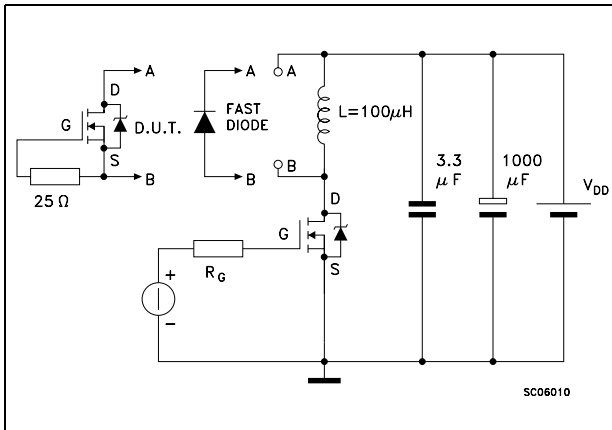

Figure 19. Unclamped Inductive load test circuit

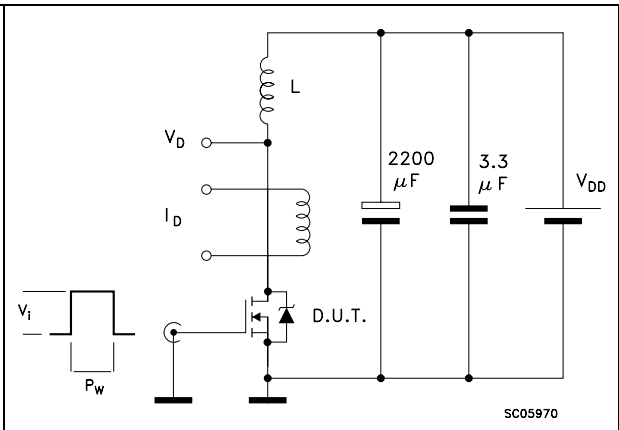

Figure 20. Unclamped inductive waveform

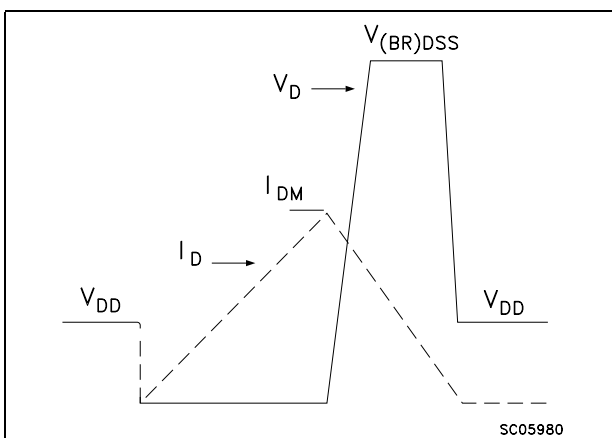
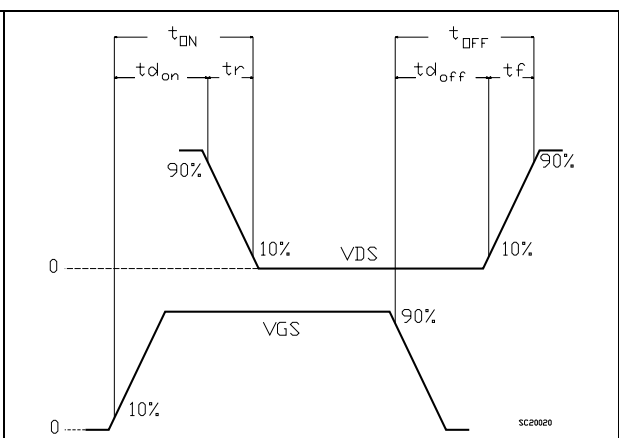

Figure 21. Switching time waveform



4 Package mechanical data

In order to meet environmental requirements, ST offers these devices in different grades of ECOPACK[®] packages, depending on their level of environmental compliance. ECOPACK[®] specifications, grade definitions and product status are available at: www.st.com. ECOPACK is an ST trademark.

TO-220 mechanical data

Dim	mm			inch		
	Min	Typ	Max	Min	Typ	Max
A	4.40		4.60	0.173		0.181
b	0.61		0.88	0.024		0.034
b1	1.14		1.70	0.044		0.066
c0	.48		0.70	0.019		0.027
D	15.25		15.75	0.6		0.62
D1		1.27			0.050	
E	10		10.40	0.393		0.409
e	2.40		2.70	0.094		0.106
e1	4.95		5.15	0.194		0.202
F1	.23		1.32	0.048		0.051
H1	6.20		6.60	0.244		0.256
J1	2.40		2.72	0.094		0.107
L1	3		14	0.511		0.551
L1	3.50		3.93	0.137		0.154
L20		16.40			0.645	
L302		8.90			1.137	
∅P	3.75		3.85	0.147		0.151
Q2	.65		2.95	0.104		0.116

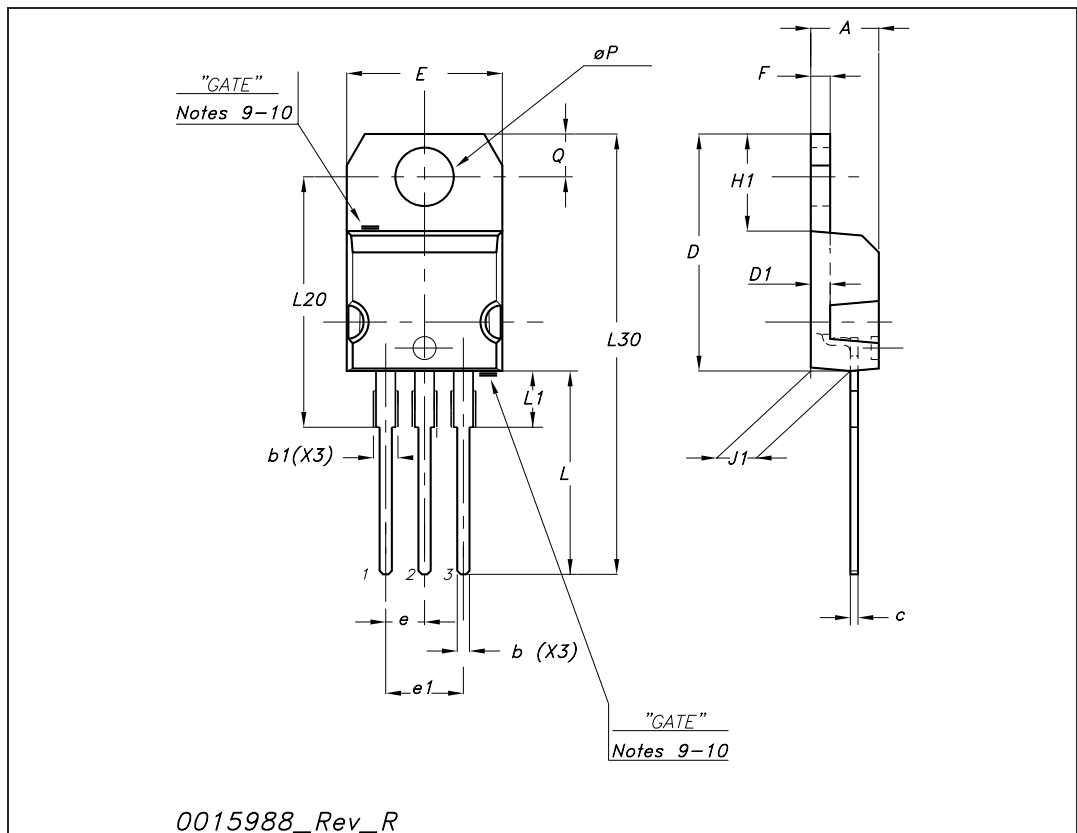

TO-220FP mechanical data

Dim.	mm.			inch		
	Min.	Typ	Max.	Min.	Typ.	Max.
A	4.40		4.60	0.173		0.181
B	2.5		2.7	0.098		0.106
D	2.5		2.75	0.098		0.108
E	0.45		0.70	0.017		0.027
F	0.75		1.00	0.0300		.039
F1	1.15		1.50	0.045		0.067
F2	1.15		1.50	0.045		0.067
G4	.955		.20	0.1950		.204
G1	2.40		2.70	0.094		0.106
H	10		10.40	0.393		0.409
L2		16			0.630	
L3	28.6		30.6	1.126		1.204
L4	9.80		10.60	0.385		0.417
L5	2.93		.6	0.114		0.141
L6	15.90		16.40	0.626		0.645
L7	99		.300	.354		0.366
Dia3			3.2	0.118		0.126

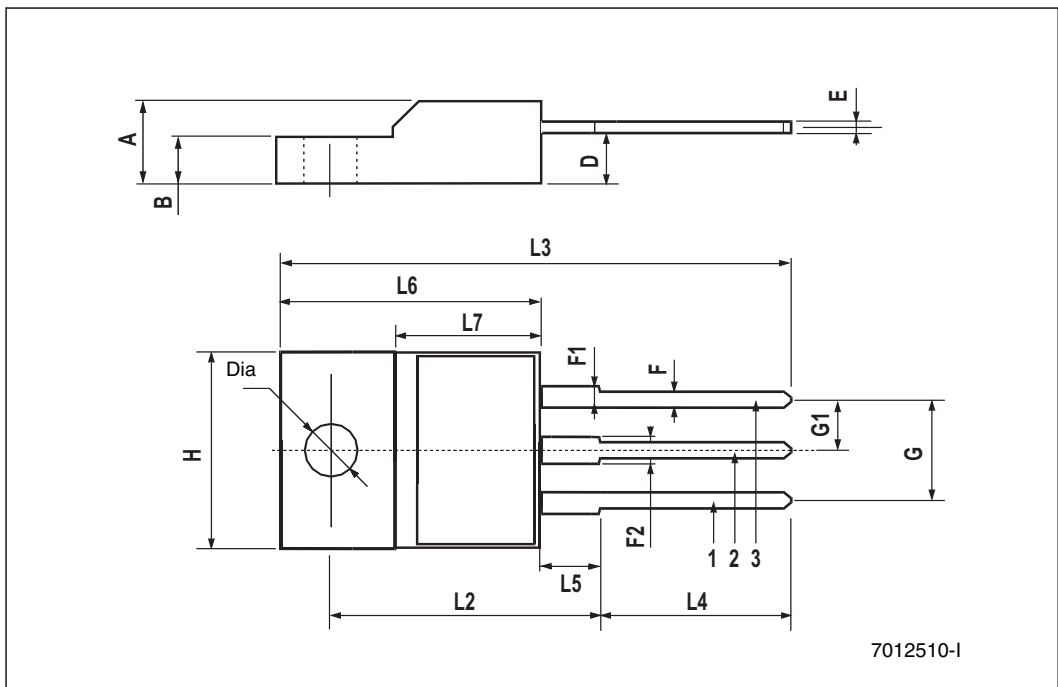

TO-251 (IPAK) mechanical data

DIM.	mm.		
	min.	typ	max.
A	2.20		2.40
A1	0.901		.10
b	0.64		0.90
b2			0.95
b4	5.20		5.40
c	0.45		0.60
c2	0.48		0.60
D	6.00		6.20
E	6.40		6.60
e2		.28	
e1	4.40		4.60
H		16.10	
L	9.00		9.40
(L1)	0.801		.20
L2		0.80	
V1		10°	

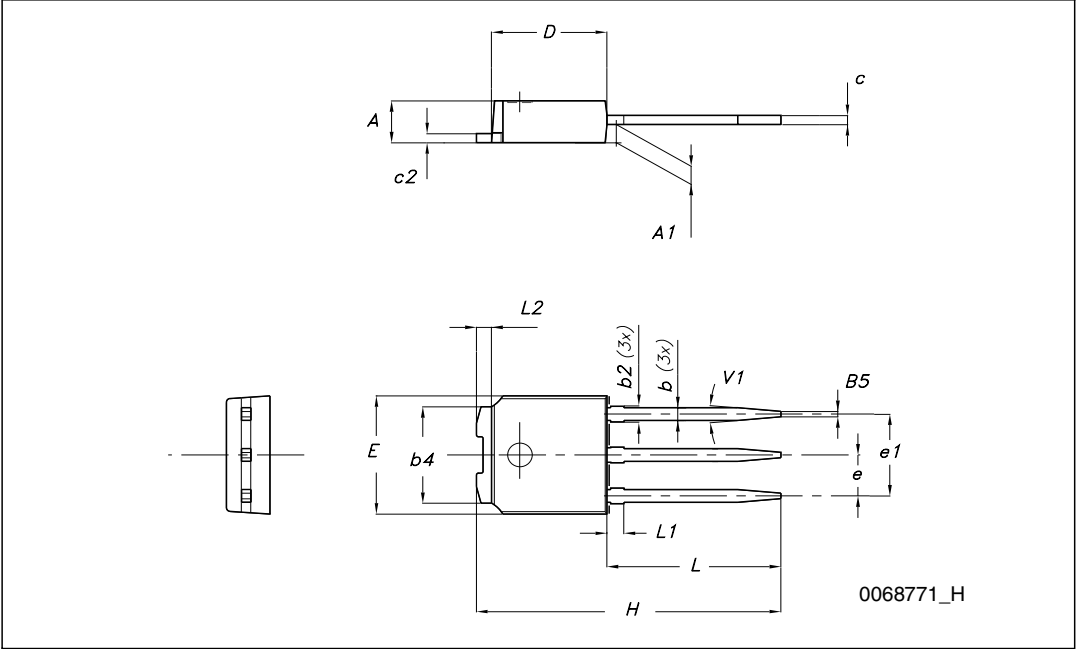

TO-252 (DPAK) mechanical data

DIM.	mm.		
	min.	typ	max.
A	2.20		2.40
A1	0.901		.10
A2	0.03		0.23
b	0.64		0.90
b4	5.20		5.40
c	0.45		0.60
c2	0.48		0.60
D	6.00		6.20
D1		5.10	
E	6.40		6.60
E1		4.70	
e2		.28	
e1	4.40		4.60
H	9.35		10.10
L1			
L1		2.80	
L2		0.80	
L4	0.60		1
R0		.20	
V2	0°		8°

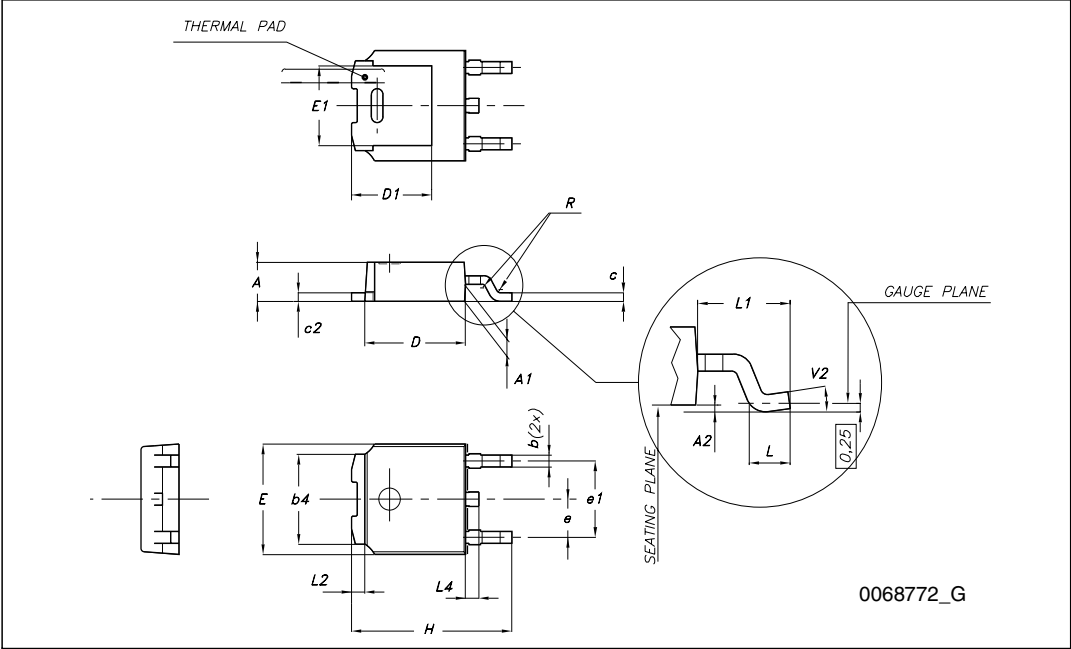

D²PAK (TO-263) mechanical data

Dim	mm			inch		
	Min	Typ	Max	Min	Typ	Max
A	4.40		4.60	0.173		0.181
A1	0.03		0.23	0.001		0.009
b	0.70		0.93	0.027		0.037
b2	1.14		1.70	0.045		0.067
c	0.45		0.60	0.017		0.024
c2	1.23		1.360	.048		0.053
D	8.95		9.350	.352		0.368
D1	7.50			0.295		
E	10		10.40	0.3940		.409
E1	8.50			0.334		
e		2.54			0.1	
e1	4.88		5.28	0.1920		.208
H1	5		15.850	.5900		.624
J1	2.49		2.69	0.099		0.106
L2	.29		2.79	0.090		0.110
L1	1.27		1.40	0.05		0.055
L2	1.30		1.75	0.051		0.069
R		0.4			0.016	
V2	0°		8°0	°		8°

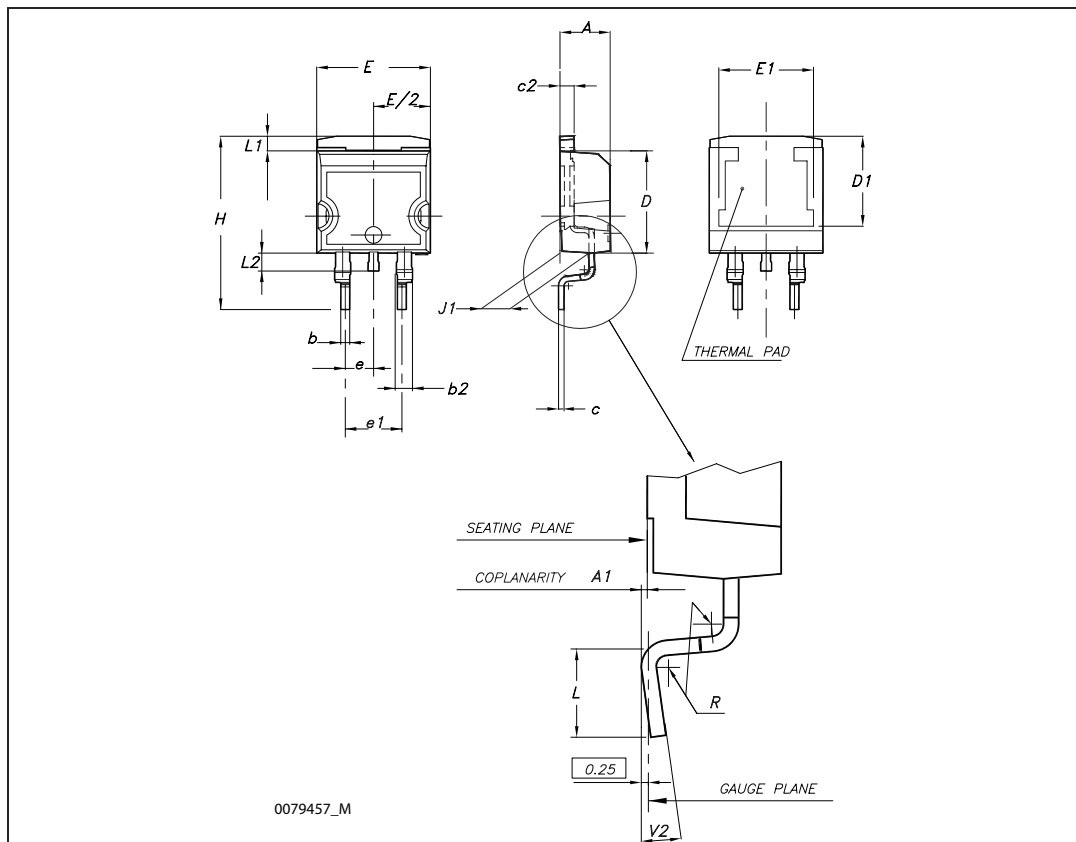

5 Package mechanical data

DPAK FOOTPRINT

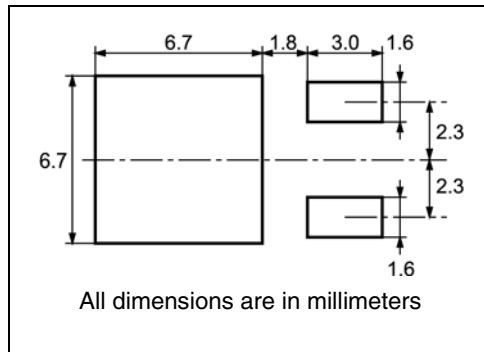

TAPE AND REEL SHIPMENT

40 mm min. Access hole at slot location

Full radius

Tape slot in core for tape start 2.5mm min. width

G measured at hub

REEL MECHANICAL DATA

DIM.	mm		inch	
	MIN.	MAX.	MIN.	MAX.
A		330		12.992
B	1.5		0.059	
C	12.8	13.2	0.504	0.520
D	20.2		0.795	
G	16.4	18.4	0.645	0.724
N	50		1.968	
T		22.4		0.881

TAPE MECHANICAL DATA

DIM.	mm		inch	
	MIN.	MAX.	MIN.	MAX.
A0	6.8	7	0.267	0.275
B0	10.4	10.6	0.409	0.417
B1		12.1		0.476
D	1.5	1.6	0.059	0.063
D1	1.5		0.059	
E	1.65	1.85	0.065	0.073
F	7.4	7.6	0.291	0.299
K0	2.55	2.75	0.100	0.108
P0	3.9	4.1	0.153	0.161
P1	7.9	8.1	0.311	0.319
P2	1.9	2.1	0.075	0.082
R	40		1.574	
W	15.7	16.3	0.618	0.641

10 pitches cumulative tolerance on tape ± 0.2 mm

TOP COVER TAPE

User Direction of Feed

Center line of cavity

For machine ref. only including draft and radii concentric around B0

FEED DIRECTION

Bending radius R min.

D²PAK FOOTPRINT

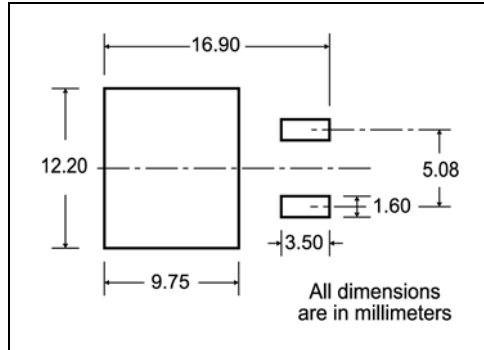

TAPE AND REEL SHIPMENT

TAPE MECHANICAL DATA

DIM.	mm		inch	
	MIN.	MAX.	MIN.	MAX.
A0	10.5	10.7	0.413	0.421
B0	15.7	15.9	0.618	0.626
D	1.5	1.6	0.059	0.063
D1	1.59	1.61	0.062	0.063
E	1.65	1.85	0.065	0.073
F	11.4	11.6	0.449	0.456
K0	4.8	5.0	0.189	0.197
P0	3.9	4.1	0.153	0.161
P1	11.9	12.1	0.468	0.476
P2	1.9	2.1	0.075	0.082
R	50		1.574	
T	0.25	0.35	0.0098	0.0137
W	23.7	24.3	0.933	0.956

REEL MECHANICAL DATA

DIM.	mm		inch	
	MIN.	MAX.	MIN.	MAX.
A		330		12.992
B	1.5		0.059	
C	12.8	13.2	0.504	0.520
D	20.2		0.795	
G	24.4	26.4	0.960	1.039
N	100		3.937	
T		30.4		1.197

BASE QTY	BULK QTY
1000	1000

TR

* on sales type

6 Revision history

Table 10. Document revision history

Date	Revision	Changes
10-Jul-2008	1	First release
17-Aug-2009	2	Modified: marking of the Table 1

Please Read Carefully:

Information in this document is provided solely in connection with ST products. STMicroelectronics NV and its subsidiaries ("ST") reserve the right to make changes, corrections, modifications or improvements, to this document, and the products and services described herein at any time, without notice.

All ST products are sold pursuant to ST's terms and conditions of sale.

Purchasers are solely responsible for the choice, selection and use of the ST products and services described herein, and ST assumes no liability whatsoever relating to the choice, selection or use of the ST products and services described herein.

No license, express or implied, by estoppel or otherwise, to any intellectual property rights is granted under this document. If any part of this document refers to any third party products or services it shall not be deemed a license grant by ST for the use of such third party products or services, or any intellectual property contained therein or considered as a warranty covering the use in any manner whatsoever of such third party products or services or any intellectual property contained therein.

UNLESS OTHERWISE SET FORTH IN ST'S TERMS AND CONDITIONS OF SALE ST DISCLAIMS ANY EXPRESS OR IMPLIED WARRANTY WITH RESPECT TO THE USE AND/OR SALE OF ST PRODUCTS INCLUDING WITHOUT LIMITATION IMPLIED WARRANTIES OF MERCHANTABILITY, FITNESS FOR A PARTICULAR PURPOSE (AND THEIR EQUIVALENTS UNDER THE LAWS OF ANY JURISDICTION), OR INFRINGEMENT OF ANY PATENT, COPYRIGHT OR OTHER INTELLECTUAL PROPERTY RIGHT.

UNLESS EXPRESSLY APPROVED IN WRITING BY AN AUTHORIZED ST REPRESENTATIVE, ST PRODUCTS ARE NOT RECOMMENDED, AUTHORIZED OR WARRANTED FOR USE IN MILITARY, AIR CRAFT, SPACE, LIFE SAVING, OR LIFE SUSTAINING APPLICATIONS, NOR IN PRODUCTS OR SYSTEMS WHERE FAILURE OR MALFUNCTION MAY RESULT IN PERSONAL INJURY, DEATH, OR SEVERE PROPERTY OR ENVIRONMENTAL DAMAGE. ST PRODUCTS WHICH ARE NOT SPECIFIED AS "AUTOMOTIVE GRADE" MAY ONLY BE USED IN AUTOMOTIVE APPLICATIONS AT USER'S OWN RISK.

Resale of ST products with provisions different from the statements and/or technical features set forth in this document shall immediately void any warranty granted by ST for the ST product or service described herein and shall not create or extend in any manner whatsoever, any liability of ST.

ST and the ST logo are trademarks or registered trademarks of ST in various countries.

Information in this document supersedes and replaces all information previously supplied.

The ST logo is a registered trademark of STMicroelectronics. All other names are the property of their respective owners.

© 2009 STMicroelectronics - All rights reserved

STMicroelectronics group of companies

Australia - Belgium - Brazil - Canada - China - Czech Republic - Finland - France - Germany - Hong Kong - India - Israel - Italy - Japan - Malaysia - Malta - Morocco - Philippines - Singapore - Spain - Sweden - Switzerland - United Kingdom - United States of America

www.st.com