

isc N-Channel MOSFET Transistor

3N75

• FEATURES

- Drain Current $I_D=3.0A@ T_C=25^\circ C$
- Drain Source Voltage-
: $V_{DSS}= 750V(\text{Min})$
- Static Drain-Source On-Resistance
: $R_{DS(on)} = 7.0 \Omega (\text{Max})$
- Fast Switching
- Minimum Lot-to-Lot variations for robust device performance and reliable operation

• APPLICATIONS

- Switching power supplies,converters,AC and DC motor controls

• ABSOLUTE MAXIMUM RATINGS($T_a=25^\circ C$)

SYMBOL	PARAMETER	VALUE	UNIT
V_{DSS}	Drain-Source Voltage	750	V
V_{GS}	Gate-Source Voltage-Continuous	± 30	V
I_D	Drain Current-Continuous	3	A
I_{DM}	Drain Current-Single Plused	8	A
P_D	Total Dissipation @ $T_C=25^\circ C$	75	W
T_j	Max. Operating Junction Temperature	150	$^\circ C$
T_{stg}	Storage Temperature	-55~150	$^\circ C$

• THERMAL CHARACTERISTICS

SYMBOL	PARAMETER	MAX	UNIT
$R_{th j-c}$	Thermal Resistance, Junction to Case	1.67	$^\circ C/W$
$R_{th j-a}$	Thermal Resistance,Junction to Ambient	62.5	$^\circ C/W$

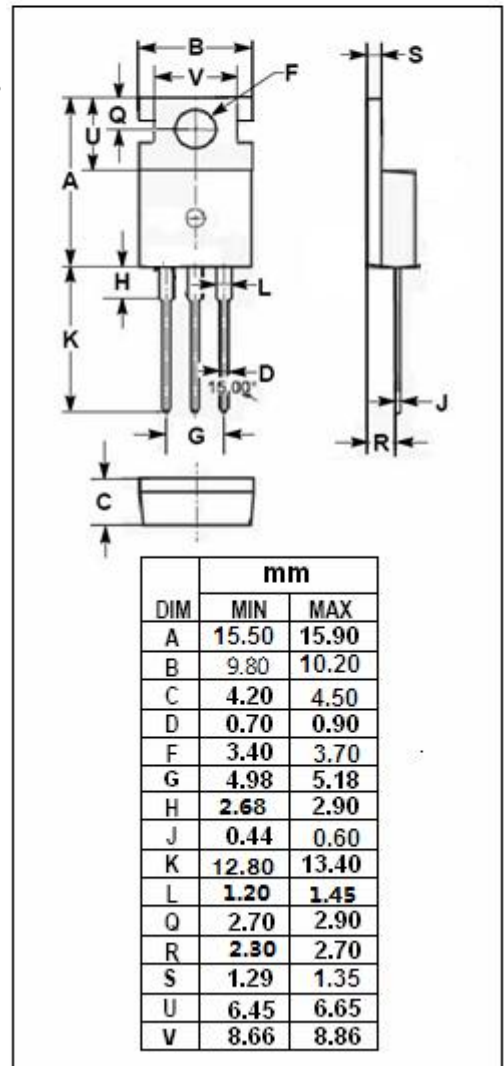
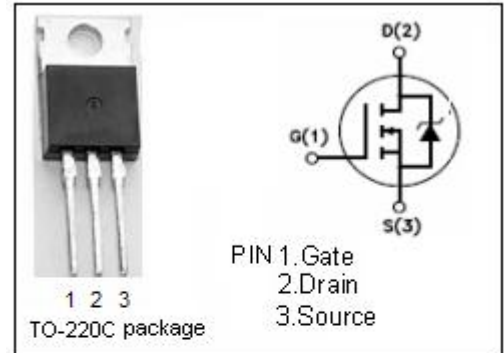

isc N-Channel MOSFET Transistor
3N75
• ELECTRICAL CHARACTERISTICS

 T_c=25°C unless otherwise specified

SYMBOL	PARAMETER	CONDITIONS	MIN	TYPE	MAX	UNIT
V _{(BR)DSS}	Drain-Source Breakdown Voltage	V _{GS} = 0; I _D =250μA	750			V
V _{GS(th)}	Gate Threshold Voltage	V _{DS} = V _{GS} ; I _D =1mA	2.0		4.5	V
V _{SD}	Diode Forward On-voltage	I _S = 3A; V _{GS} = 0			1.5	V
R _{DS(on)}	Drain-Source On-Resistance	V _{GS} = 10V; I _D = 1.5A			7.0	Ω
I _{GSS}	Gate-Body Leakage Current	V _{GS} = ±20V; V _{DS} = 0			±100	nA
I _{DSS}	Zero Gate Voltage Drain Current	V _{DS} =750V; V _{GS} = 0			10	μA
t _r	Rise Time	V _{GS} =10V; I _D =1.5A; V _{DD} =125V; R _L =50 Ω			150	ns
t _{d(on)}	Turn-on Delay Time				50	
t _f	Fall Time				100	
t _{d(off)}	Turn-off Delay Time				200	

NOTICE:

ISC reserves the rights to make changes of the content herein the datasheet at any time without notification. The information contained herein is presented only as a guide for the applications of our products.

ISC products are intended for usage in general electronic equipment. The products are not designed for use in equipment which require specialized quality and/or reliability, or in equipment which could have applications in hazardous environments, aerospace industry, or medical field. Please contact us if you intend our products to be used in these special applications.

ISC makes no warranty or guarantee regarding the suitability of its products for any particular purpose, nor does ISC assume any liability arising from the application or use of any products, and specifically disclaims any and all liability, including without limitation special, consequential or incidental damages.