

N-Channel Power MOSFET (3A, 800Volts)

DESCRIPTION

The Nell **3N80** is a three-terminal silicon device with current conduction capability of 3A, fast switching speed, low on-state resistance, breakdown voltage rating of 800V, and max. threshold voltage of 5 volts.

They are designed for use in applications, such as switched mode power supplies, DC to DC converters, **PWM** motor controls, bridge circuits, and general purpose switching applications.

FEATURES

- $R_{DS(ON)} = 3.80\Omega$ (typ.) @ $V_{GS} = 10V$
- Ultra low gate charge(35nC max.)
- Low reverse transfer capacitance ($C_{RSS} = 23pF$ typical)
- Fast switching capability
- 100% avalanche energy specified
- Improved dv/dt capability
- 150°C operation temperature

PRODUCT SUMMARY

I_D (A)	3
V_{DSS} (V)	800
$R_{DS(ON)}$ (Ω) (typ.)	3.80 @ $V_{GS} = 10V$
Q_G (nC) max.	35

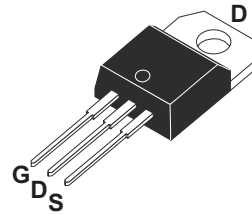

TO-220AB
(3N80A)

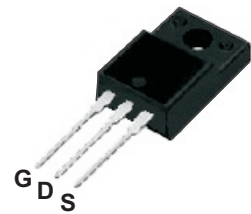

TO-220F
(3N80AF)

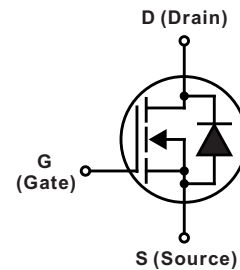

ABSOLUTE MAXIMUM RATINGS ($T_C = 25^\circ C$ unless otherwise specified)

SYMBOL	PARAMETER	TEST CONDITIONS	VALUE	UNIT	
V_{DSS}	Drain to Source voltage	$T_J = 25^\circ C$ to $150^\circ C$	800	V	
V_{DGR}	Drain to Gate voltage	$R_{GS} = 20K\Omega$	800		
V_{GS}	Gate to Source voltage		± 30		
I_D	Continuous Drain Current	$T_C = 25^\circ C$	3	A	
		$T_C = 100^\circ C$	1.9		
I_{DM}	Pulsed Drain current(Note 1)		12		
I_{AR}	Avalanche current(Note 1)		3		
E_{AR}	Repetitive avalanche energy(Note 1)	$I_{AR} = 3A, R_{GS} = 50\Omega, V_{GS} = 10V$	10	mJ	
E_{AS}	Single pulse avalanche energy(Note 2)	$I_{AS} = 3A, L = 50mH$	240		
dv/dt	Peak diode recovery dv/dt(Note 3)		2.0	V/ns	
P_D	Total power dissipation (Derate above $25^\circ C$)	$T_C = 25^\circ C$	TO-220AB	100 (0.80)	W/(W/°C)
			TO-220F	54 (0.43)	
T_J	Operation junction temperature		-55 to 150	°C	
T_{STG}	Storage temperature		-55 to 150		
T_L	Maximum soldering temperature, for 10 seconds	1.6mm from case	300		
	Mounting torque, #6-32 or M3 screw		10 (1.1)	lbf-in (N-m)	

Note: 1. Repetitive rating: pulse width limited by junction temperature..

2. $I_{AS} = 3A, V_{DD} = 50V, L = 50mH, R_{GS} = 27\Omega$, starting $T_J = 25^\circ C$.

3. $I_{SD} \leq 3A, di/dt \leq 100A/\mu s, V_{DD} \leq V_{(BR)DSS}$, starting $T_J = 25^\circ C$.

THERMAL RESISTANCE						
SYMBOL	PARAMETER		Min.	Typ.	Max.	UNIT
$R_{th(j-c)}$	Thermal resistance, junction to case	TO-220AB			1.25	°C/W
		TO-220F			3.20	
$R_{th(j-a)}$	Thermal resistance, junction to ambient	TO-220AB/TO-220F			62.5	

ELECTRICAL CHARACTERISTICS ($T_C = 25^\circ\text{C}$ unless otherwise specified)						
SYMBOL	PARAMETER	TEST CONDITIONS	Min.	Typ.	Max.	UNIT
OFF CHARACTERISTICS						
$V_{(BR)DSS}$	Drain to source breakdown voltage	$I_D = 250\mu\text{A}, V_{GS} = 0\text{V}$	800			V
$\Delta V_{(BR)DSS}/\Delta T_J$	Breakdown voltage temperature coefficient	$I_D = 250\mu\text{A}, V_{DS} = V_{GS}$		1.00		V/°C
I_{DSS}	Drain to source leakage current	$V_{DS} = 800\text{V}, V_{GS} = 0\text{V}$ $T_C = 25^\circ\text{C}$			1	μA
		$V_{DS} = 640\text{V}, V_{GS} = 0\text{V}$ $T_C = 125^\circ\text{C}$			20	
I_{GSS}	Gate to source forward leakage current	$V_{GS} = 30\text{V}, V_{DS} = 0\text{V}$			100	nA
	Gate to source reverse leakage current	$V_{GS} = -30\text{V}, V_{DS} = 0\text{V}$			-100	
ON CHARACTERISTICS						
$R_{DS(ON)}$	Static drain to source on-state resistance	$I_D = 1.5\text{A}, V_{GS} = 10\text{V}$		3.8	4.5	Ω
$V_{GS(TH)}$	Gate threshold voltage	$V_{GS} = V_{DS}, I_D = 250\mu\text{A}$	2.5		4.5	V
g_{fs}	Forward transconductance (Note 1)	$V_{DS} = 50\text{V}, I_D = 1.5\text{A}$		2.2		S
DYNAMIC CHARACTERISTICS						
C_{ISS}	Input capacitance	$V_{DS} = 25\text{V}, V_{GS} = 0\text{V}, f = 1\text{MHz}$		580	750	μF
C_{OSS}	Output capacitance		60	75		
C_{RSS}	Reverse transfer capacitance		23	30		
SWITCHING CHARACTERISTICS						
$t_{d(ON)}$	Turn-on delay time	$V_{DD} = 400\text{V}, V_{GS} = 10\text{V}, I_D = 3\text{A}, R_{GS} = 25\Omega$ (Note 1, 2)		20	40	ns
t_r	Rise time		28	80		
$t_{d(OFF)}$	Turn-off delay time		45	100		
t_f	Fall time		30	75		
Q_G	Total gate charge	$V_{DD} = 640\text{V}, V_{GS} = 10\text{V}, I_D = 3\text{A}$ (Note 1, 2)		27	35	nC
Q_{GS}	Gate to source charge		5			
Q_{GD}	Gate to drain charge (Miller charge)		10			

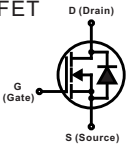
SOURCE TO DRAIN DIODE RATINGS AND CHARACTERISTICS ($T_C = 25^\circ\text{C}$ unless otherwise specified)						
SYMBOL	PARAMETER	TEST CONDITIONS	Min.	Typ.	Max.	UNIT
V_{SD}	Diode forward voltage	$I_{SD} = 3\text{A}, V_{GS} = 0\text{V}$			1.4	V
I_S (I_{SD})	Continuous source to drain current	Integral reverse P-N junction diode in the MOSFET 			3	A
I_{SM}	Pulsed source current		12			
t_{rr}	Reverse recovery time	$I_{SD} = 3\text{A}, V_{GS} = 0\text{V}, dI_F/dt = 100\text{A}/\mu\text{s}$		380		ns
Q_{rr}	Reverse recovery charge			1.6		μC

Note: 1. Pulse test: Pulse width $\leq 250\mu\text{s}$, duty cycle $\leq 2\%$.
 2. Essentially independent of operating temperature.

ORDERING INFORMATION SCHEME

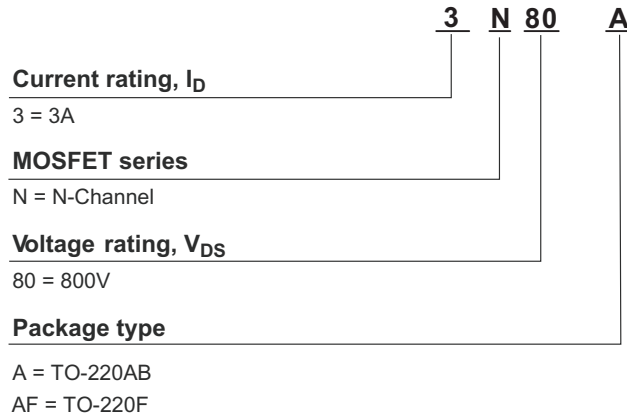

Fig.1 Output characteristics

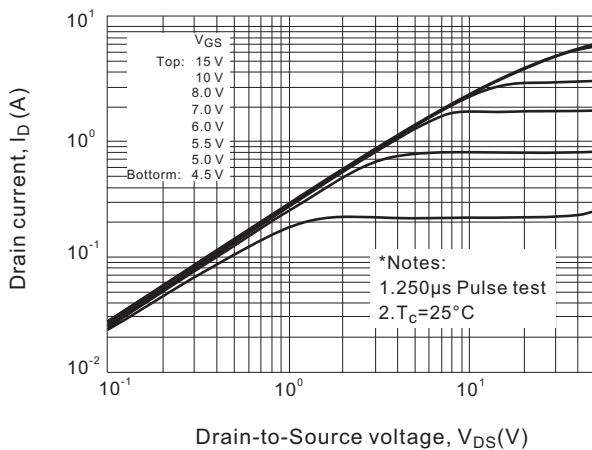

Fig.2 Transfer characteristics

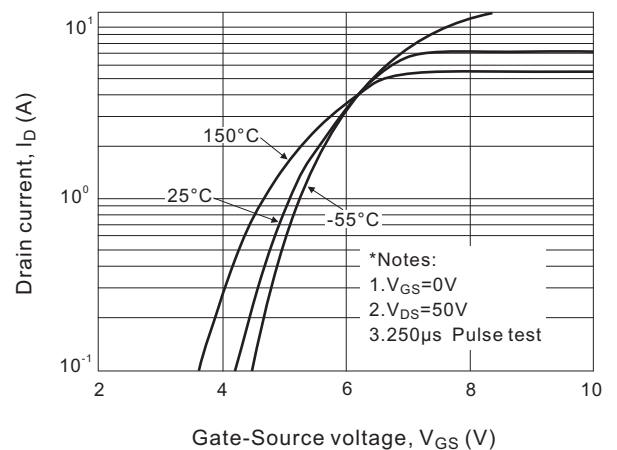

Fig.3 On-resistance variation vs. drain current

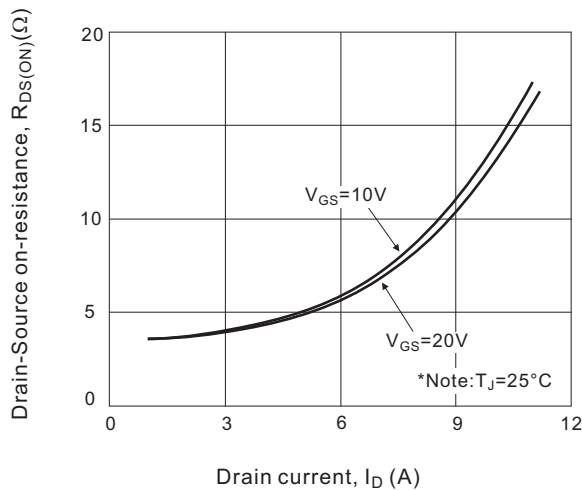

Fig.4 Source-drain diode forward voltage

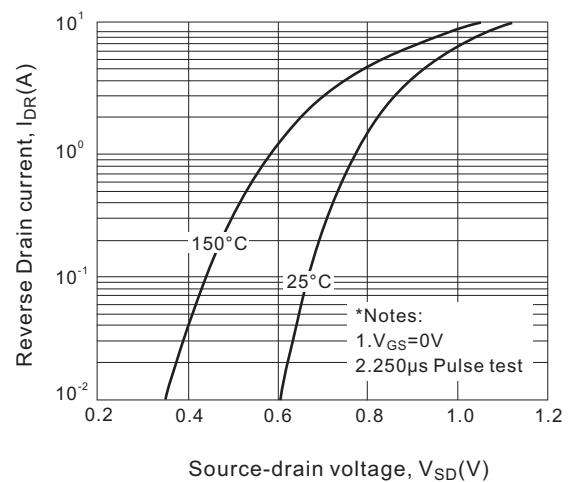

Fig.5 Capacitance vs. drain-source voltage

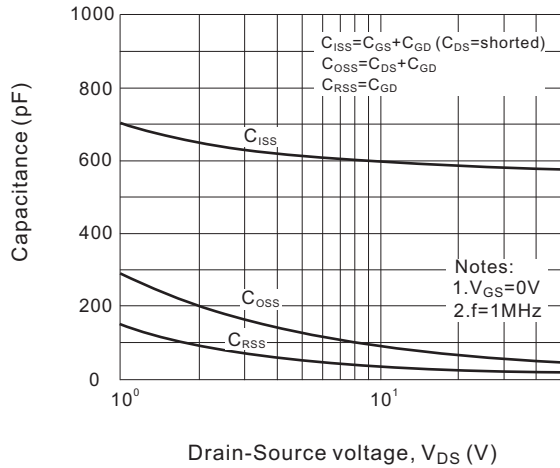

Fig.6 Gate charge vs. gate-source voltage

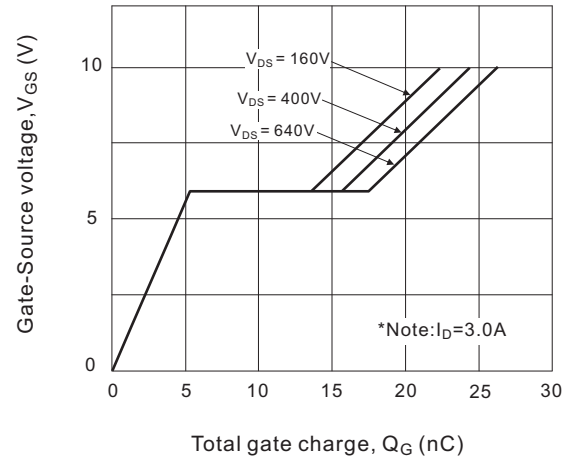

Fig.7 Breakdown voltage variation vs. temperature

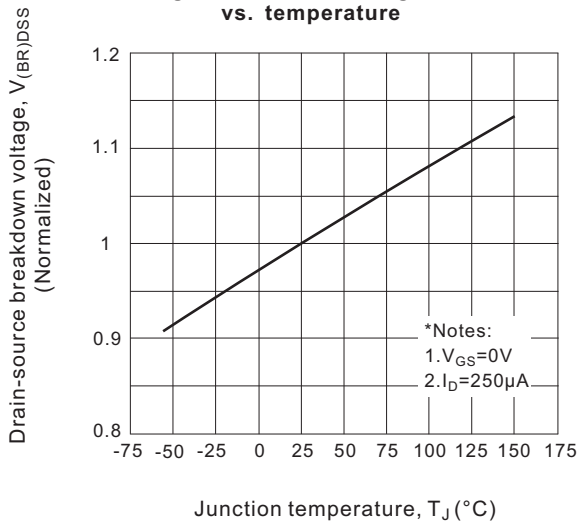

Fig.8 On-resistance vs. temperature

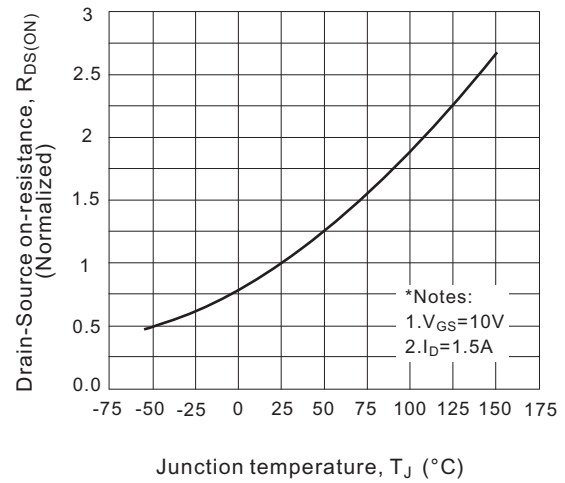

Fig.9-1 Maximum safe operating area for 3N80A

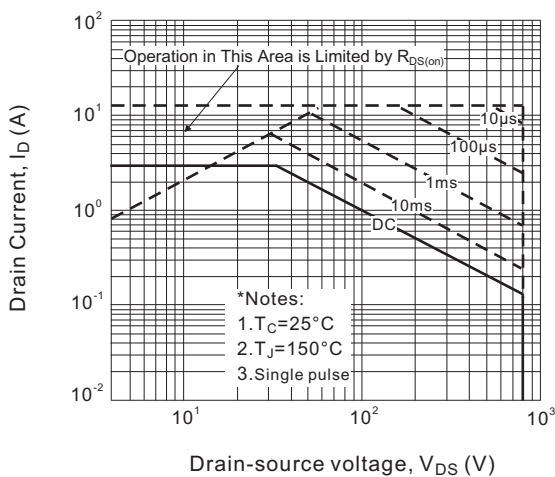

Fig.9-2 Maximum safe operating area for 3N80AF

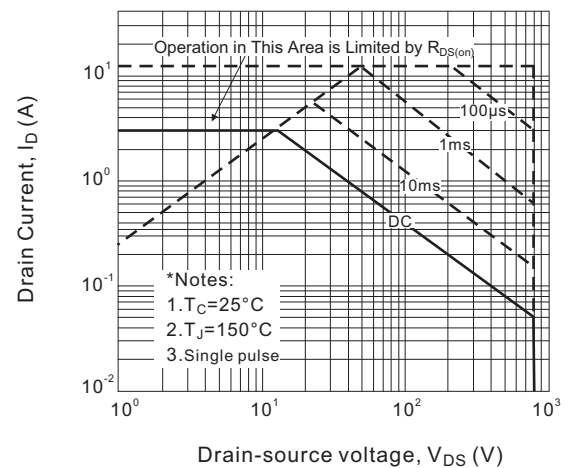

Fig.10 Maximum drain current vs. case temperature

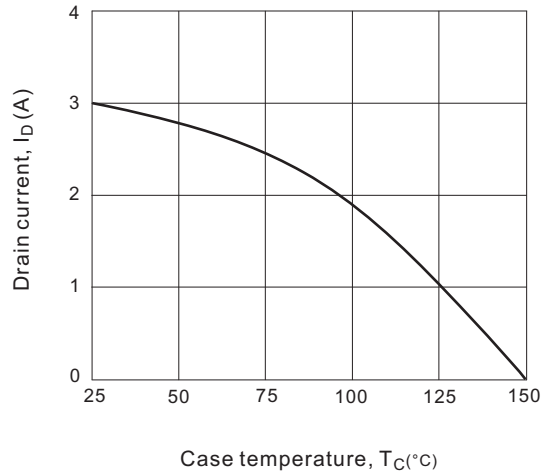

Fig.11-1 Transient Thermal Response Curve for 3N80A

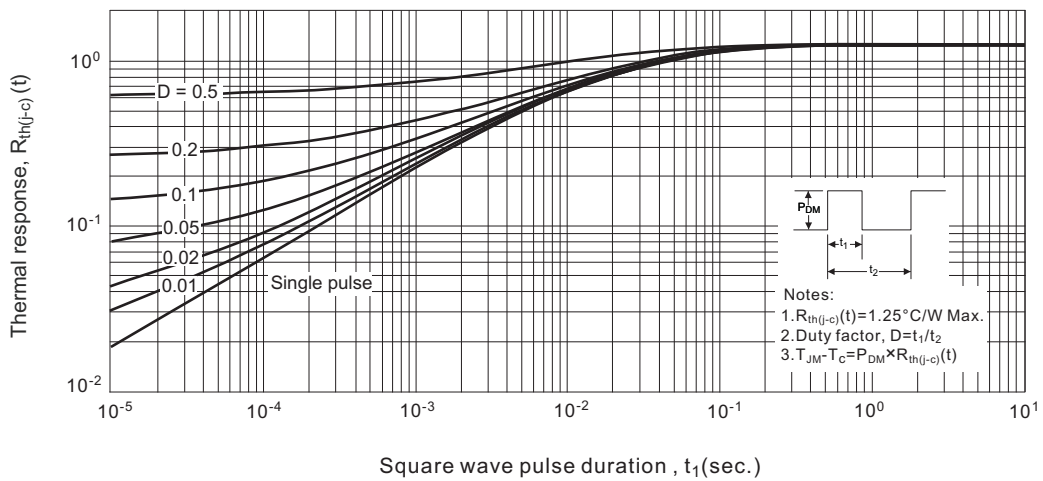
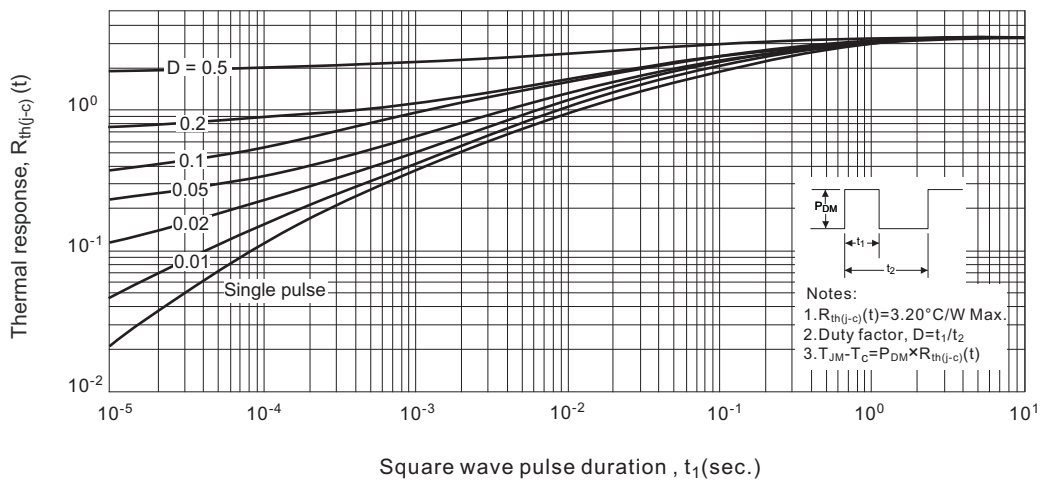

Fig.11-2 Transient Thermal Response Curve for 3N80AF



TEST CIRCUITS AND WAVEFORMS

Fig.1A Peak diode recovery dv/dt test circuit

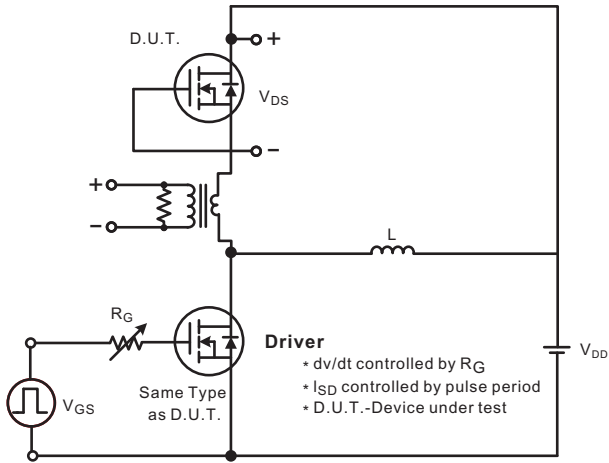

Fig.1B Peak diode recovery dv/dt waveforms

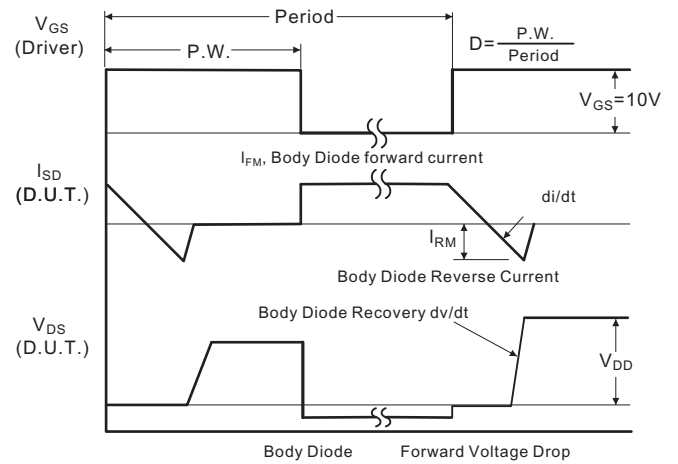

Fig.2A Switching test circuit

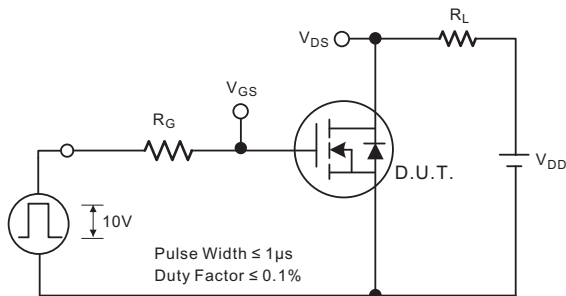

Fig.2B Switching Waveforms

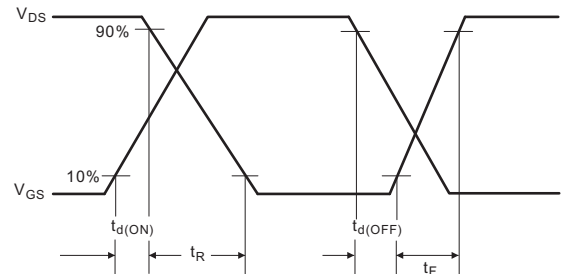

Fig.3A Gate charge test circuit

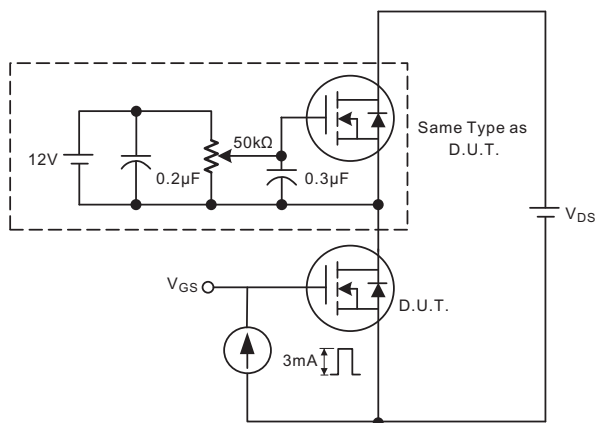

Fig.3B Gate charge waveform

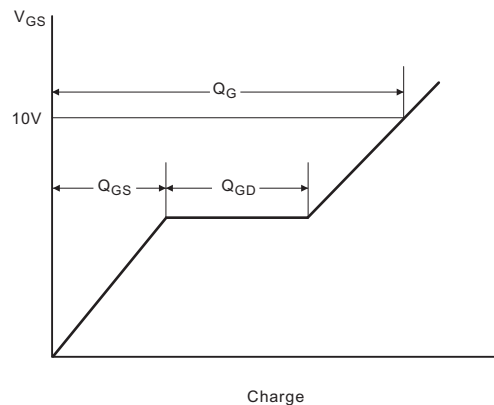

Fig.4A Unclamped Inductive switching test circuit

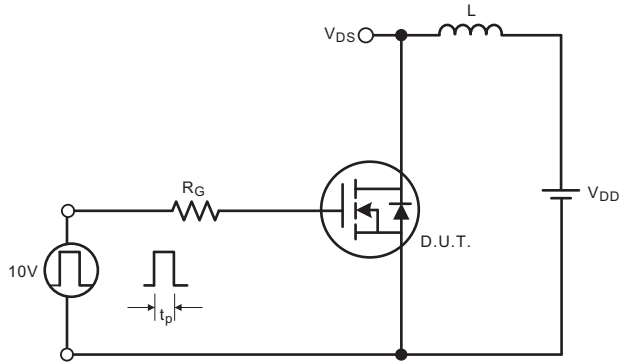
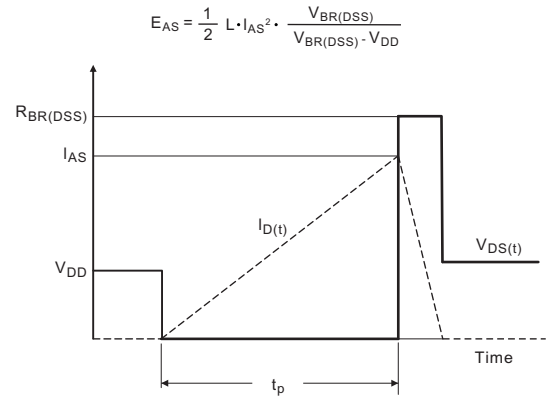
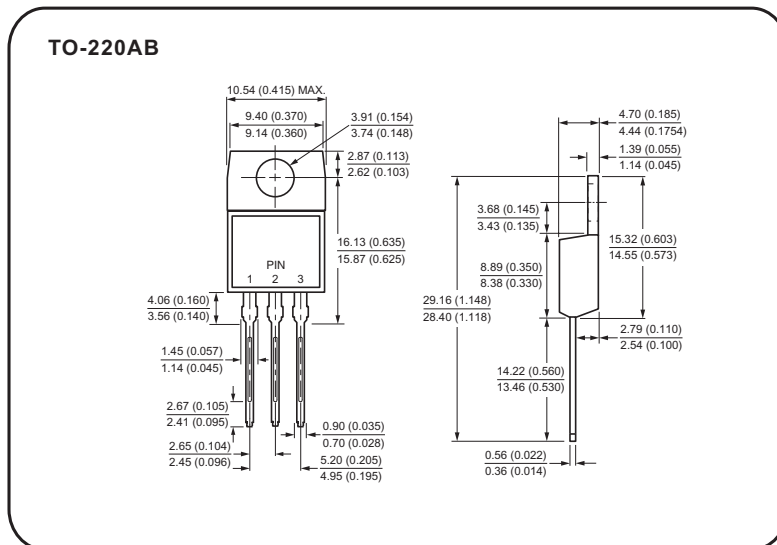

Fig.4B Unclamped Inductive switching waveforms



Case Style



Case Style

TO-220F

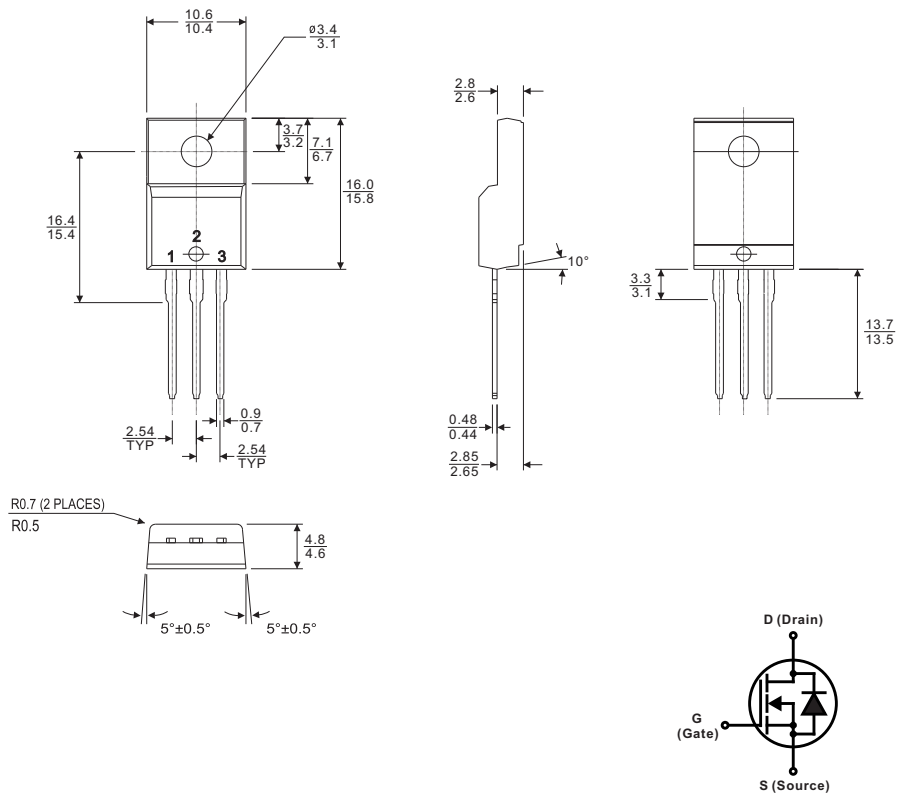

All dimensions in millimeters