

**SONY****3SK165**

## GaAs N-Channel Dual-Gate MES FET

### Description

The 3SK165 is a GaAs N-Channel Dual-Gate MES FET for low noise UHF amplifiers and mixers. Low noise and high gain characteristics are accomplished by optimum mask pattern design. Easier high frequency circuit adjustments are made possible by the miniaturized plastic molded package which contributes to reduce parasitic elements of the device.

### Features

- Low NF      NF = 1.2dB (typ.) at 800MHz
- High PG      PG = 20dB (typ.) at 800MHz
- High stability

### Applications

- UHF amplifier, mixer, oscillator

### Absolute Maximum Ratings (Ta = +25°C)

• Drain to source voltage	V <sub>DSX</sub>	8	V
• Gate 1 to source voltage	V <sub>G1S</sub>	-6	V
• Gate 2 to source voltage	V <sub>G2S</sub>	-6	V
• Drain current	I <sub>D</sub>	80	mA
• Channel temperature	T <sub>ch</sub>	150	°C
• Storage temperature	T <sub>stg</sub>	-55 to +150	°C
• Allowable power dissipation	P <sub>D</sub>	150	mW

DataShee

www.DataSheet4U.com

DataSheet4U.com

## Electrical Characteristics

Item	Symbol	Condition	Min.	Typ.	Max.	Unit
Drain to source voltage	V <sub>DSX</sub>	I <sub>D</sub> = 200μA V <sub>G1S</sub> = 0V V <sub>G2S</sub> = -5V	8			V
Gate 1 cutoff current	I <sub>G1SS</sub>	V <sub>G1S</sub> = -4V V <sub>G2S</sub> = 0V V <sub>DS</sub> = 0V			-20	μA
Gate 2 cutoff current	I <sub>G2SS</sub>	V <sub>G2S</sub> = -4V V <sub>G1S</sub> = 0V V <sub>DS</sub> = 0V			-20	μA
Drain saturation current	I <sub>DSS</sub> (1)	V <sub>DS</sub> = 5V V <sub>G1S</sub> = 0V V <sub>G2S</sub> = 0V	20		55	mA
Gate 1 cutoff voltage	V <sub>G1S</sub> (OFF)	V <sub>DS</sub> = 5V I <sub>D</sub> = 100μA V <sub>G2S</sub> = 0V	-1		-4	V
Gate 2 cutoff voltage	V <sub>G2S</sub> (OFF)	V <sub>DS</sub> = 5V I <sub>D</sub> = 100μA V <sub>G1S</sub> = 0V	-1		-4	V
Forward transfer admittance	g <sub>m</sub>	V <sub>DS</sub> = 5V I <sub>D</sub> = 10mA V <sub>G2S</sub> = 1.5V f = 1KHz	15	22		mS
Input capacitance	C <sub>iss</sub>	V <sub>DS</sub> = 5V I <sub>D</sub> = 10mA		0.5	1.0	pF
Reverse transfer capacitance	C <sub>rss</sub>	V <sub>G2S</sub> = 1.5V f = 1MHz		7.5	25	fF
Power Gain	PG	V <sub>DS</sub> = 5V I <sub>D</sub> = 10mA	16	20		dB
Noise figure	NF	V <sub>G2S</sub> = 1.5V f = 800MHz		1.2	2.5	dB

## NOTE:

## 1. Classification

Rank	I <sub>DSS</sub>	Unit
3SK165-0	20-55	mA
3SK165-1	20-35	mA
3SK165-2	30-55	mA

Mark

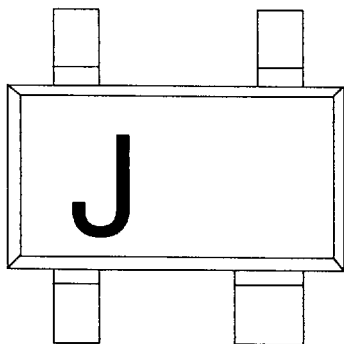
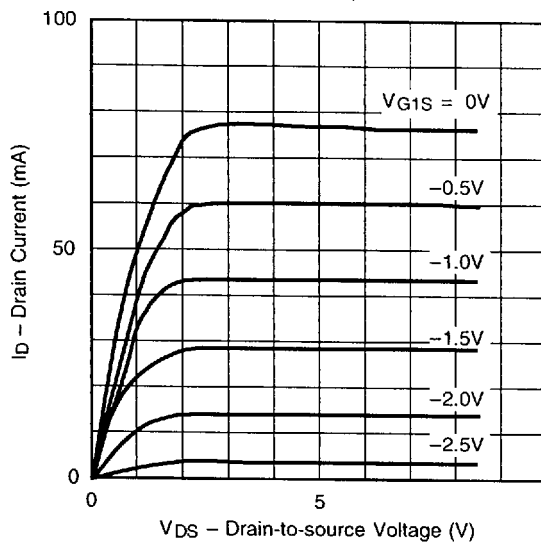
**Output Characteristics**(Ta = +25°C, V<sub>G2S</sub> = 1.5V, V<sub>G1S</sub> = -0.5V/step)

DataSheet4U.com

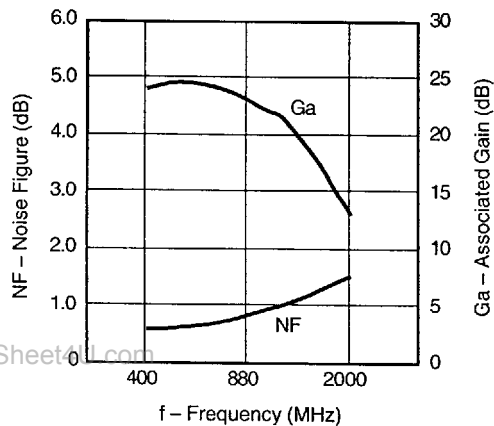
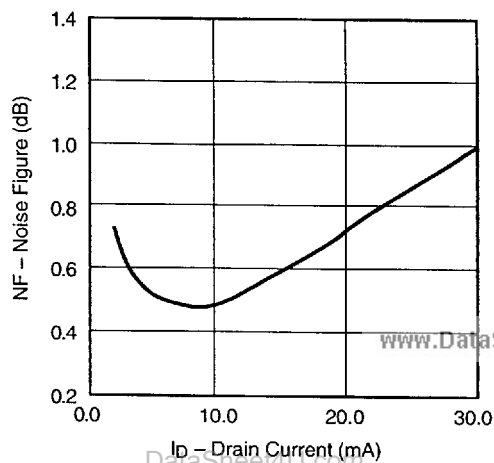
**NF, Ga Frequency Dependence**(V<sub>DS</sub> = 5.0V, V<sub>G2S</sub> = 1.5V, I<sub>D</sub> = 10mA)**NF-I<sub>D</sub> Characteristics**(V<sub>DS</sub> = 5.0V, V<sub>G2S</sub> = 1.5V, Frequency at 450MHz)

www.DataSheet4U.com

DataSheet4U.com

## Application Circuit (Front-end Amplifier)

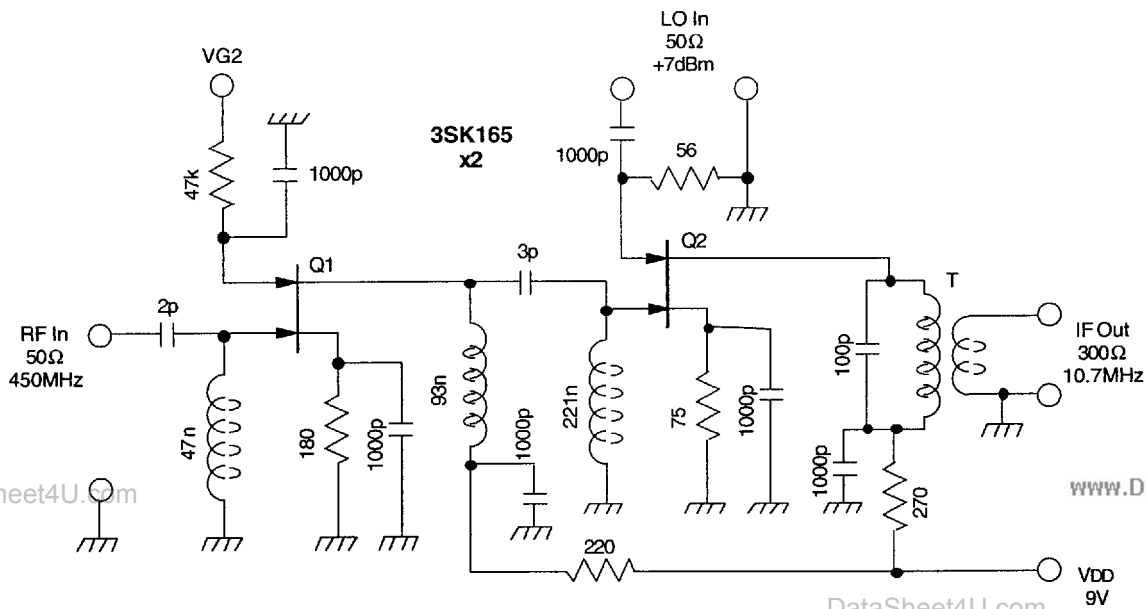
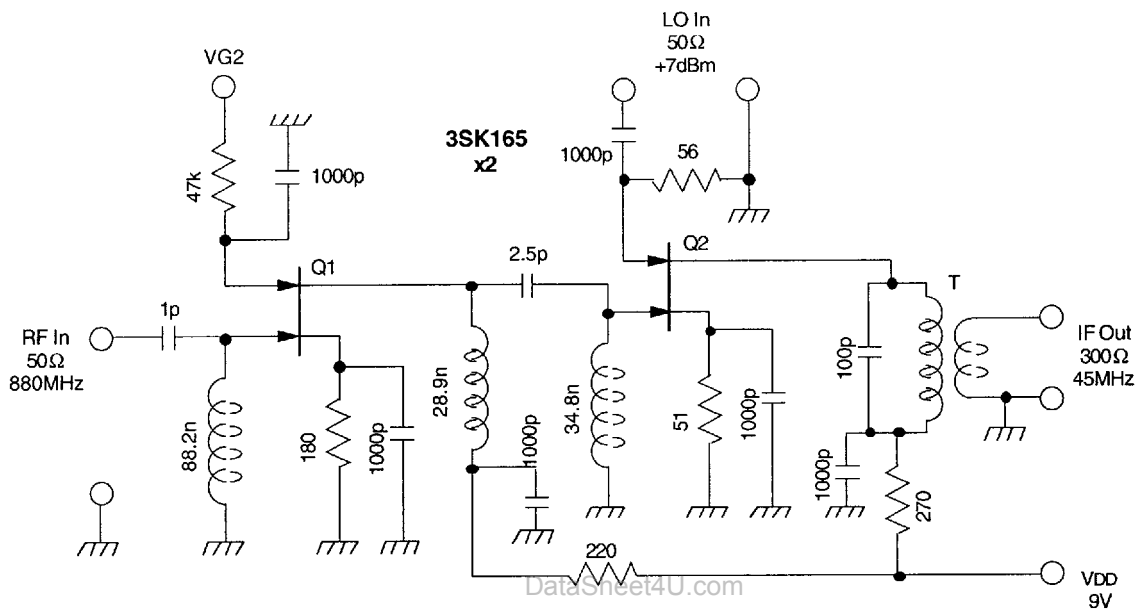

## S-Parameters vs. Frequency Characteristics

(VDS = 5.0V, VG2S = 1.5V, ID = 10mA)

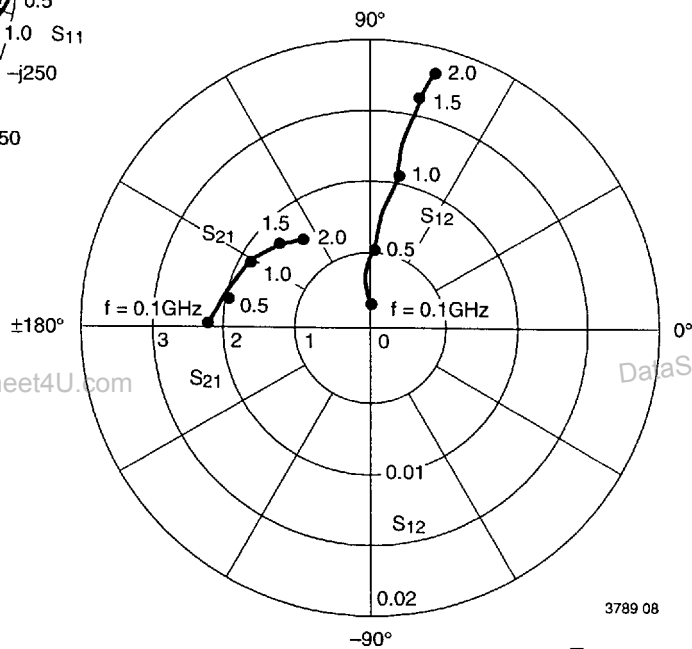
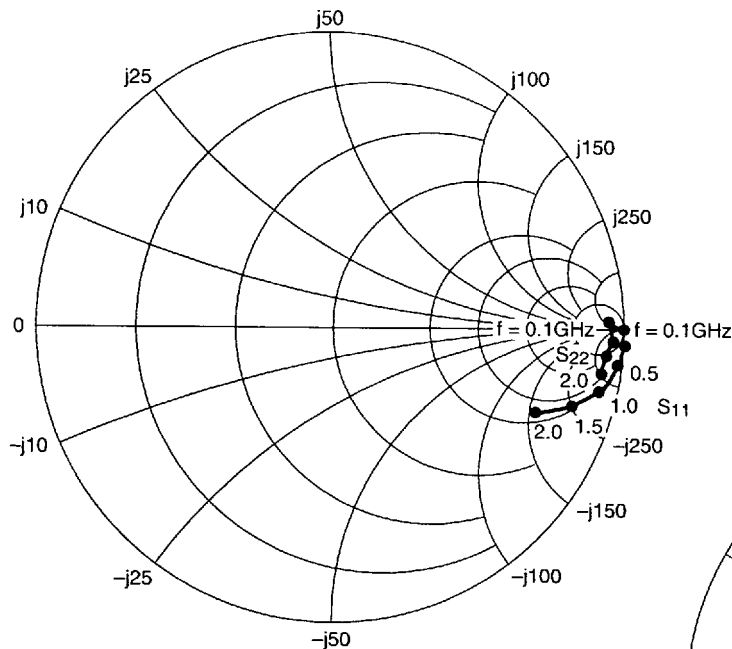

3789 08

## S-Parameter Data of FET 3SK165

Zo = 50Ω

Frequency MHz	S11		S21		S12		S22	
	MAG	ANG	MAG	ANG	MAG	ANG	MAG	ANG
100	.999	-1.60	2.065	177.40	0.0011	88.48	.961	-.77
200	.998	-2.97	2.044	172.69	0.0021	93.67	.961	-1.85
300	.999	-4.28	2.180	169.86	0.0023	105.04	.971	-2.98
400	.993	-5.70	2.077	170.12	0.0049	89.67	.958	-3.51
500	.989	-6.98	1.981	167.14	0.0054	83.41	.958	-4.17
600	.979	-8.16	1.999	161.04	0.0068	83.94	.960	-5.09
700	.969	-9.57	2.004	160.63	0.0082	83.47	.955	-5.68
800	.958	-10.84	1.957	159.23	0.0084	82.97	.955	-6.83
900	.948	-12.16	1.856	153.88	0.0091	79.56	.948	-7.22
1000	.938	-13.23	1.938	150.58	0.0106	78.17	.949	-8.58
1200	.912	-15.27	1.789	147.43	0.0131	79.92	.941	-10.37
1400	.877	-17.11	1.823	139.04	0.0151	74.26	.936	-12.06
1600	.841	-19.12	1.700	137.04	0.0156	78.12	.935	-13.26
1800	.805	-21.04	1.704	132.09	0.0171	77.47	.928	-13.91
2000	.756	-22.32	1.448	126.14	0.0176	76.07	.922	-14.46

## Noise Figure Characteristics

(V<sub>DS</sub> = 0.5V, V<sub>G2S</sub> = 1.5V, I<sub>D</sub> = 10mA)

at 450MHz

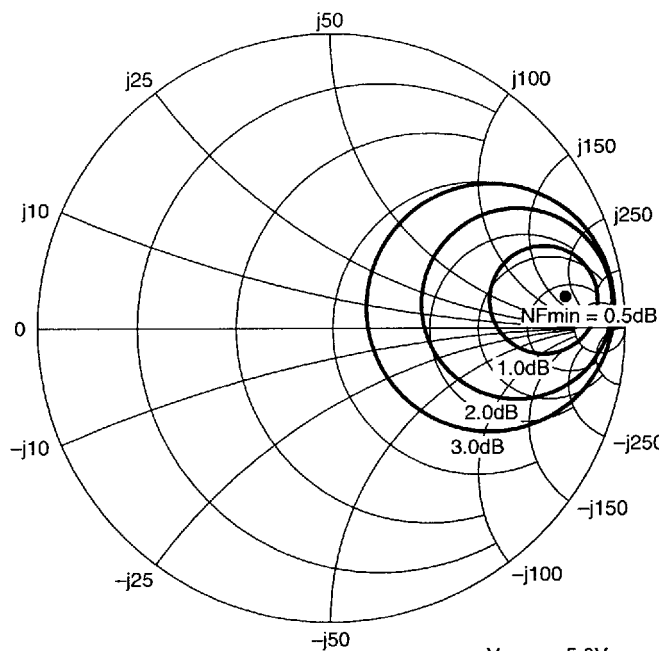

V<sub>DS</sub> = 5.0V  
 V<sub>G2S</sub> = 1.5V  
 I<sub>D</sub> = 10mA  
 Frequency 450MHz  
 NF min. 0.50dB  
 Ga 23.83dB  
 Gamma (S); MAG 0.799 ANG 7.78°  
 Gamma (L); MAG 0.887 ANG 7.31°

at 880MHz

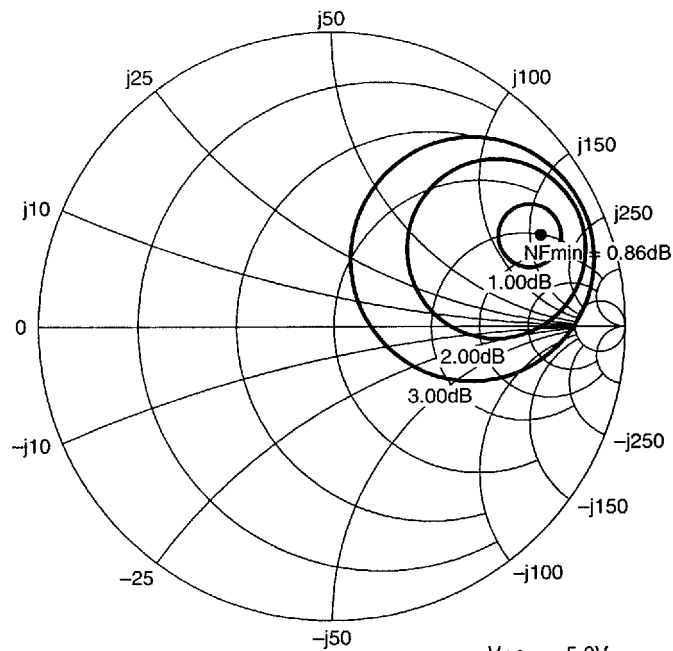

V<sub>DS</sub> = 5.0V  
 V<sub>G2S</sub> = 1.5V  
 I<sub>D</sub> = 10mA  
 Frequency 880MHz  
 NF min. 0.86dB  
 Ga 23.70dB  
 Gamma (S); MAG 0.771 ANG 25.07°  
 Gamma (L); MAG 0.830 ANG 21.84°

at 2000MHz

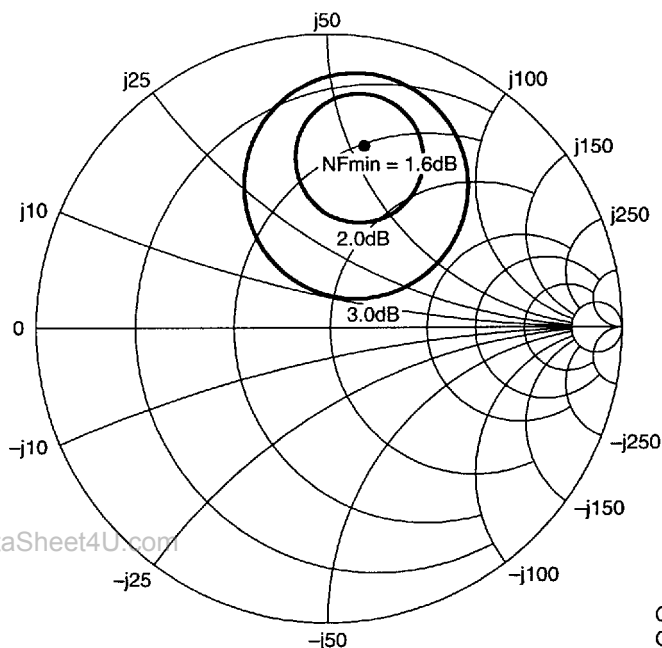

V<sub>DS</sub> = 5.0V  
 V<sub>G2S</sub> = 1.5V  
 I<sub>D</sub> = 10mA  
 Frequency 2000MHz  
 NF min. 1.60dB  
 Ga 12.91dB  
 Gamma (S); MAG 0.643 ANG 78.48°  
 Gamma (L); MAG 0.559 ANG 46.00°

Frequency (MHz)	Ga (dB)	NF (dB)	Gamma-S		Gamma-L	
			MAG	ANG	MAG	ANG
400	23.54	0.59	0.824	3.16°	0.910	8.75°
450	23.83	0.50	0.799	7.78°	0.887	7.31°
500	22.79	0.47	0.792	12.03°	0.848	14.56°
880	23.70	0.86	0.771	25.07°	0.830	21.84°
2000	12.92	1.60	0.643	78.48°	0.559	46.00°

## Package Outline

Unit: mm

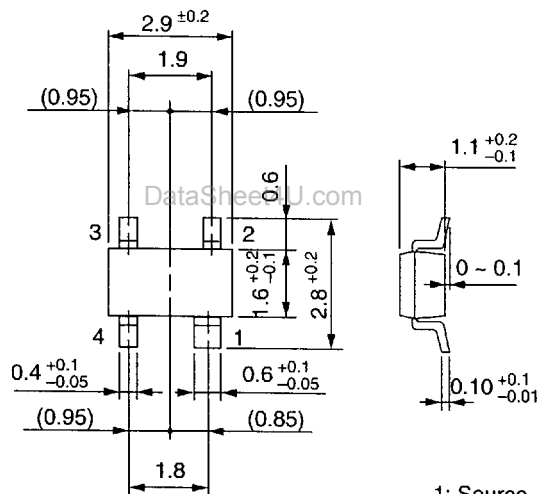

- 1: Source
- 2: Gate 1
- 3: Gate 2
- 4: Drain