

# SuperPlanar™ Bridge Rectifiers

## 3SPB35J--3SPB35K

### Features

- Planar passivated chips
- Ultra low leakage reverse current
- High temperature performance
- High surge current capability
- Ideal for printed circuit boards
- High temperature soldering guaranteed:  
260°C/10 seconds



### Mechanical Data

- Case: 3SPB molded plastic
- Molding compound, UL flammability classification rating 94V-0
- Terminals: Leads solderable per MIL-STD-750,
- Mounting position: Any

### Maximum Ratings (@T<sub>A</sub> = 25°C unless otherwise specified)

Characteristic		Symbol	3SPB35J	3SPB35K	Units
Peak repetitive reverse voltage		V <sub>RRM</sub>	600	800	V
RMS reverse voltage		V <sub>RMS</sub>	420	560	V
DC blocking voltage		V <sub>DC</sub>	600	800	V
Maximum average forward output current		I <sub>F(AV)</sub>	3.5		A
Peak forward surge current, 8.3ms single half-sine-wave	@T <sub>J</sub> = 25°C	I <sub>FSM</sub>	135		A
I <sup>2</sup> t Rating for fusing (t=8.3ms)	@T <sub>J</sub> = 25°C	I <sup>2</sup> t	76		A <sup>2</sup> s

### Thermal Characteristics

Parameter	Symbol	3SPB35J	3SPB35K	Units
Typical thermal resistance per leg (Note 1)	R <sub>θJA</sub>	38		°C/W
	R <sub>θJC</sub>	10.4		
	R <sub>θJL</sub>	7.5		
Operating junction temperature range	T <sub>J</sub>	- 55 ---- + 150		°C
Storage temperature range	T <sub>STG</sub>	- 55 ---- + 150		°C

Note:

1. Device mounted on PCB with 10 mm x 20 mm x 0.1mm copper pad areas

**SuperPlanar™ Bridge Rectifiers**
**3SPB35J--3SPB35K**
**Electrical Characteristics** (@T<sub>A</sub> = 25°C unless otherwise specified)

Parameter	Symbol	Test conditions	Typ.	Max.	Units	
Maximum instantaneous forward voltage	V <sub>F</sub>	I <sub>F</sub> =1.75A Per Diode	0.92	0.95	V	
		I <sub>F</sub> =3.5A Per Diode	0.95	1.0		
Maximum Reverse current	I <sub>R</sub>	Rated V <sub>R</sub> , Per Diode	@T <sub>A</sub> =25°C	0.2	1	μA
			@T <sub>A</sub> =150°C	30	100	

# SuperPlanar™ Bridge Rectifiers

3SPB35J--3SPB35K

## Ratings and Characteristic Curves ( $T_A=25^\circ\text{C}$ unless otherwise noted)

Fig.1-Forward Current Derating Curve

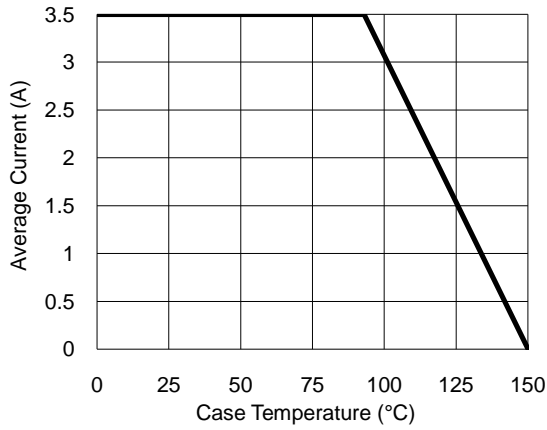

Fig.2- Surge Current Derating Curve

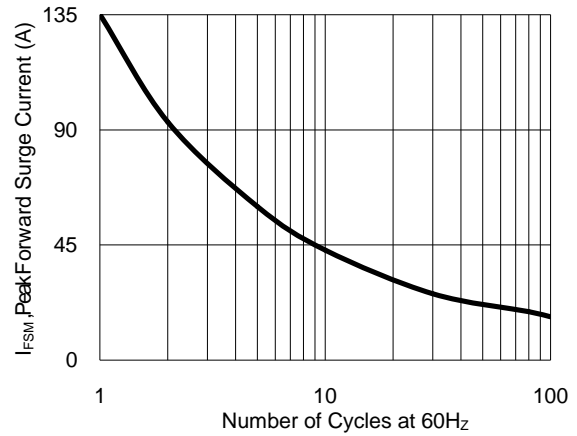

Fig.3- Typical Forward Voltage Characteristic

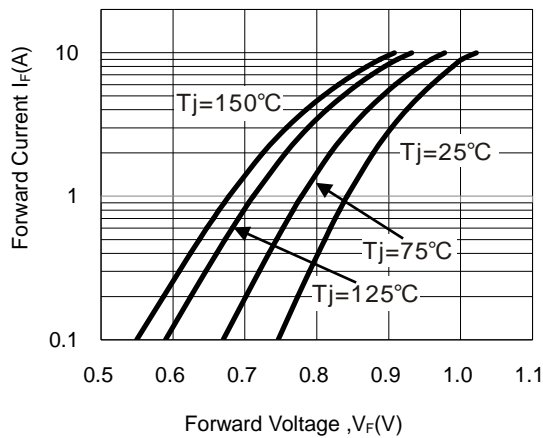
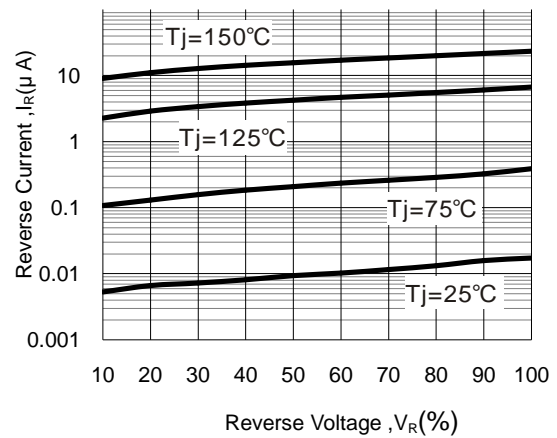

Fig.4- Typical Reverse Characteristic



# SuperPlanar™ Bridge Rectifiers

3SPB35J--3SPB35K

## Package Outline Dimensions(unit:mm)

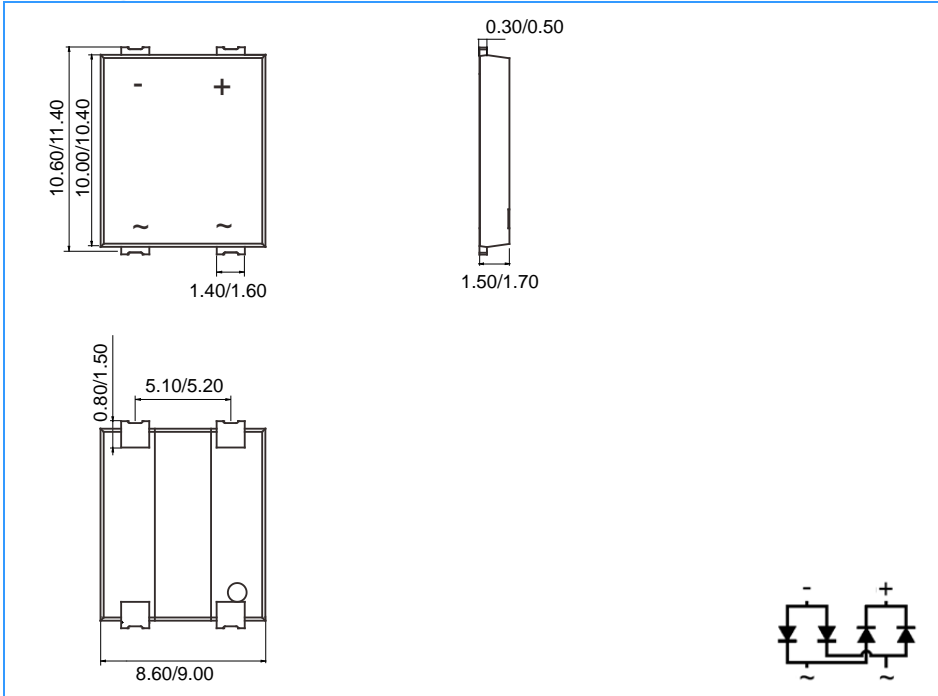

## Mounting Pad Layout(unit:mm)

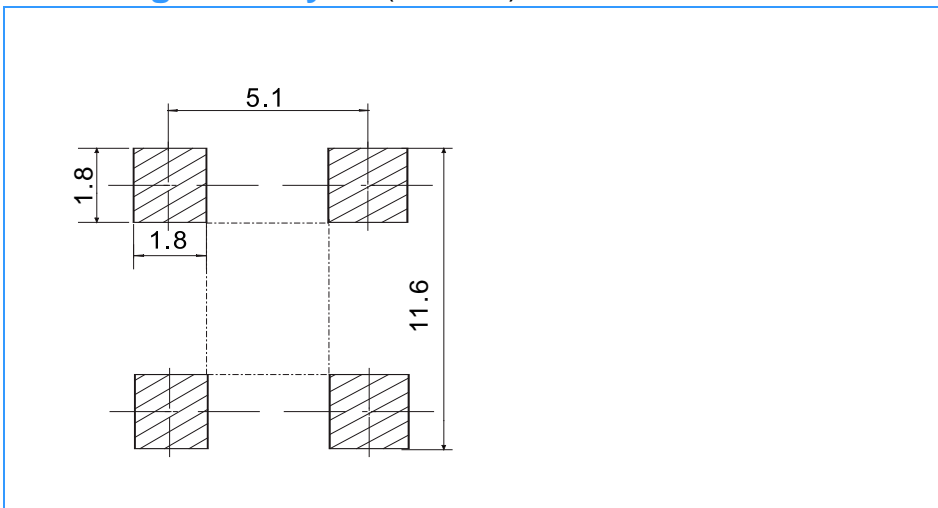

## Ordering Information

Part No.	Marking	Package	Shipping
3SPB35J	3SPB35J	3SPB	1500 /Tape&Reel
3SPB35K	3SPB35K	3SPB	1500 /Tape&Reel