

± 15V Dual-Tracking Voltage Regulator

GENERAL DESCRIPTION

The XR-4195 is a dual-polarity tracking regulator designed to provide balanced positive and negative 15V output voltages at currents of up to 100mA.

The device is ideal for local "on-card" regulation, which eliminates the distribution problems associated with single-point regulation. Intended for ease of application, the XR-4195 requires only two external components for operation.

FEATURES

- Direct Replacement for RM/RC 4195
- ± 15V Operational Amplifier Power
- Thermal Shutdown at $T_J = +175^\circ\text{C}$
- Output Currents to 100mA
- As a Single Output Regulator, it may be used with up to +50V Output
- Available in 8-Pin Plastic Mini-DIP
- Low External Parts Count

APPLICATIONS

- Operational Amplifier Supply
- On-Card Regulation
- Regulating High Voltage

ABSOLUTE MAXIMUM RATINGS

Input Voltage $\pm V$ to Ground	$\pm 30\text{ V}$
Power Dissipation at $T_A = 25^\circ\text{C}$	600 mW
Load Current	100 mA
Operating Junction Temperature Range	0°C to $+125^\circ\text{C}$
Storage Temperature Range	-65°C to $+150^\circ\text{C}$

ORDERING INFORMATION

Part Number	Package	Operating Temperature
XR-4195CP	Dip	0°C to $+70^\circ\text{C}$

FUNCTIONAL BLOCK DIAGRAM

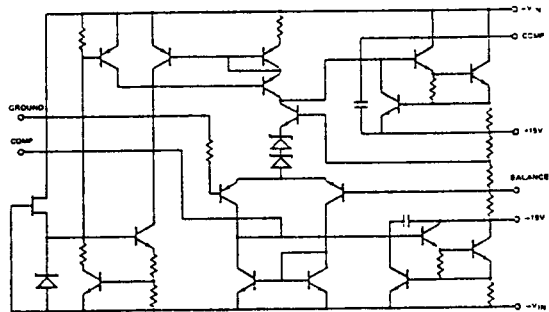
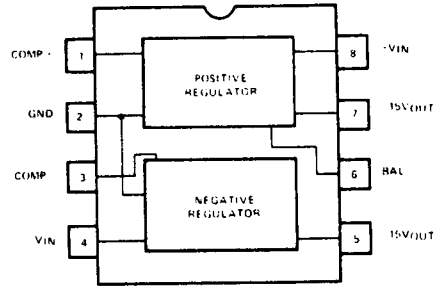

EQUIVALENT SCHEMATIC DIAGRAM

SYSTEM DESCRIPTION

The XR-4195 is a dual polarity tracking voltage regulator, internally trimmed to $\pm 15\text{V}$. Only output capacitors are required for operation. Internal protection circuits include thermal shutdown and active current limiting. The device may be configured as a single output high voltage regulator by adding a voltage divider between an output pin, the device ground (Pin 2) and system ground.

ELECTRICAL CHARACTERISTICS

Test Conditions: ($I_L = 1\text{mA}$, $V_{CC} = \pm 20\text{V}$, $C_L = 10\mu\text{F}$ unless otherwise specified)

PARAMETERS	XR-4195CP			UNITS	CONDITIONS
	MIN	TYP	MAX		
Line Regulation		2	20	mV	$V_{IN} = \pm 18$ to $\pm 30\text{V}$
Load Regulation		5	30	mV	$I_L = 1$ to 100mA
Output Voltage Temperature Stability		0.005	0.015	%/°C	
Standby Current Drain		± 1.5	± 3.0	mA	$V_{IN} = \pm 30\text{V}$, $I_L = 0\text{mA}$
Input Voltage Range	18		30	V	
Output Voltage	14.5	15	15.5	V	$T_i = +25^\circ\text{C}$
Output Voltage Tracking		± 50	± 300	mV	
Ripple Rejection		75		dB	$f = 120\text{Hz}$, $T_i = +25^\circ\text{C}$
Input-Output Voltage Differential	3			V	$I_L = 50\text{mA}$
Short-Circuit Current		220		mA	$T_i = +25^\circ\text{C}$
Output Noise Voltage		60		$\mu\text{V RMS}$	$T_i = +25^\circ\text{C}$, $f = 100\text{Hz}$ to 100kHz
Internal Thermal Shutdown		175		°C	

THERMAL CHARACTERISTICS

PARAMETERS	XR-4195CP			CONDITIONS
	MIN	TYP	MAX	
Power Dissipation			0.6W	$T_A = 25^\circ\text{C}$ $T_C = 25^\circ\text{C}$
Thermal Resistance		210°C/W		θ_{J-C} θ_{J-A}

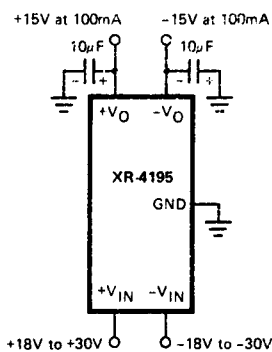

Balanced Output

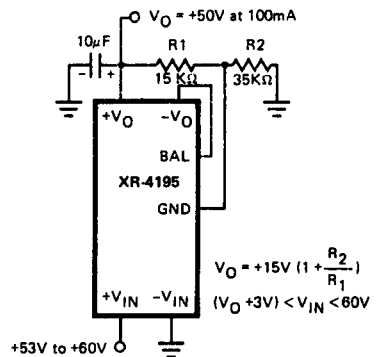

Positive Single Supply

TYPICAL APPLICATIONS

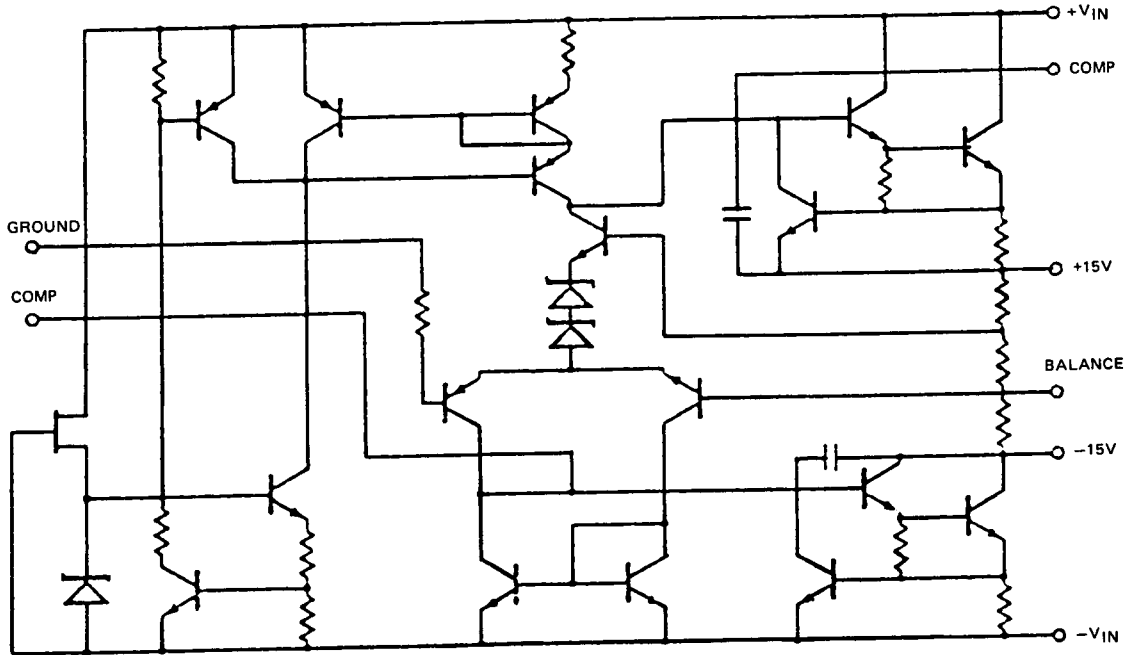

EQUIVALENT SCHEMATIC DIAGRAM

5

Quad Line Driver/Receiver

GENERAL DESCRIPTION

The XR-1488 is a monolithic quad line driver designed to interface data terminal equipment with data communications equipment in conformance with the specifications of EIA Standard No. RS232C. This extremely versatile integrated circuit can be used to perform a wide range of applications. Features such as output current limiting, independent positive and negative power supply driving elements, and compatibility with all DTL and TTL logic families greatly enhance the versatility of the circuit.

The XR-1489A is a monolithic quad line receiver designed to interface data terminal equipment with data communications equipment. The XR-1489A quad receiver along with its companion circuit, the XR-1488 quad driver, provide a complete interface system between DTL or TTL logic levels and the RS232C defined voltage and impedance levels.

ABSOLUTE MAXIMUM RATINGS

Power Supply	
XR-1488	± 15 Vdc
XR-1489A	+ 10 Vdc
Power Dissipation	
Ceramic Package	1000 mW
Derate above +25°C	6.7 mW/°C
Plastic Package	650 mW/°C
Derate above +25°C	5 mW/°C

ORDERING INFORMATION

Part Number	Package	Operating Temperature
XR-1488N	Ceramic	0°C to +70°C
XR-1488P	Plastic	0°C to +70°C
XR-1489AN	Ceramic	0°C to +70°C
XR-1489AP	Plastic	0°C to +70°C

FUNCTIONAL BLOCK DIAGRAMS

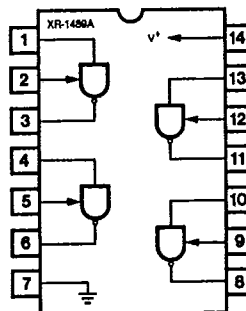
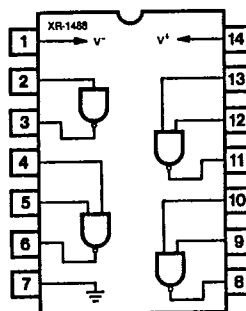

SYSTEM DESCRIPTION

The XR-1488 and XR-1489A are a matched set of quad line drivers and line receivers designed for interfacing between TTL/DTL and RS232C data communication lines.

The XR-1488 contains four independent split supply line drivers, each with a ± 10 mA current limited output. For RS232C applications, the slew rate can be reduced to the 30 V/μS limit by shunting the output to ground with a 410 pF capacitor. The XR-1489A contains four independent line receivers, designed for interfacing RS232C to TTL/DTL. Each receiver features independently programmable switching thresholds with hysteresis, and input protection to ±30 V. The output can typically source 3 mA and sink 20 mA.

XR-494

www.DataSheet4U.com

515 04478 0

T-58-11-

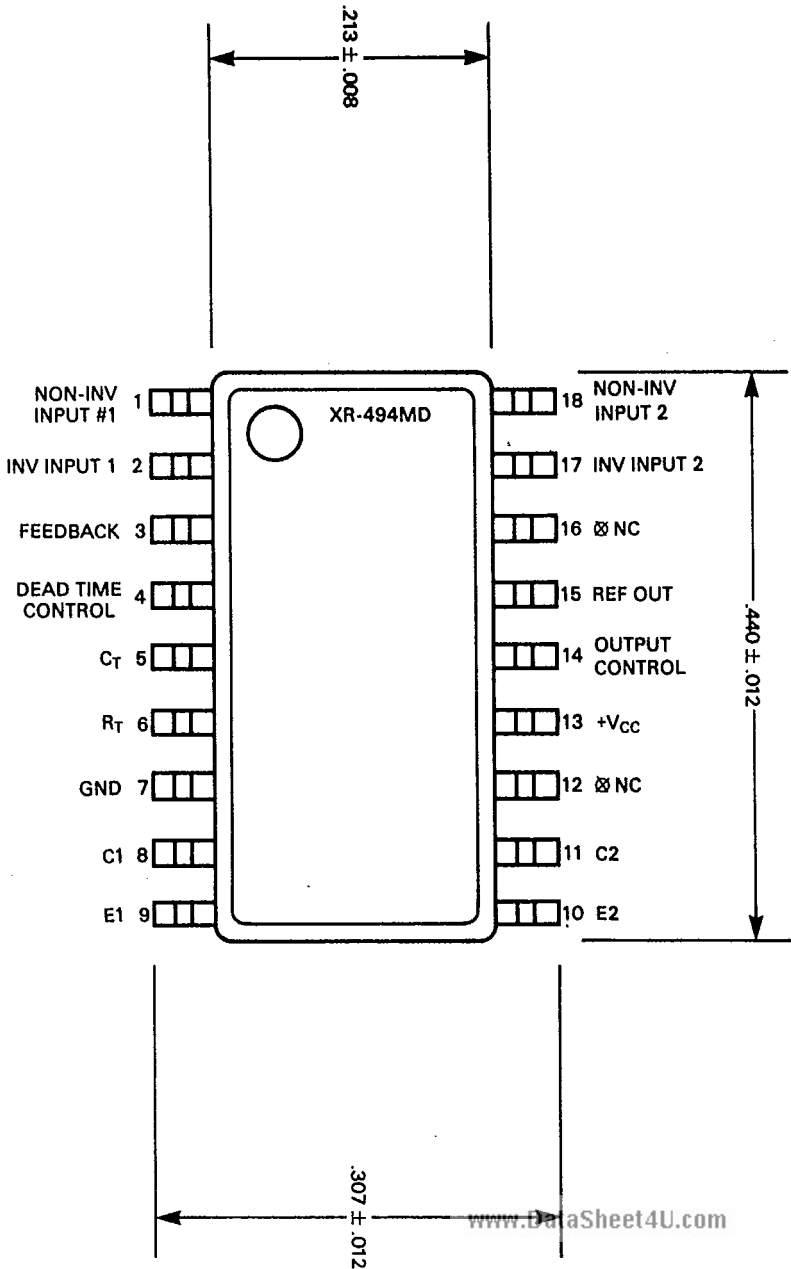

Dual-Polarity Tracking Voltage Regulator

GENERAL DESCRIPTION

The XR-1468/1568 is a dual polarity tracking voltage regulator, internally trimmed for symmetrical positive and negative 15V outputs. Current output capability is 100 mA, and may be increased by adding external pass transistors. The device is intended for local "on-card" regulation, which eliminates the distribution problems associated with single point regulation.

The XR-1468CN and XR-1568N are guaranteed over the 0°C to 70°C commercial temperature range. The XR-1568M is rated over the full military temperature range of -55°C to +125°C.

FEATURES

- Internally Set for $\pm 15V$ Outputs
- ± 100 mA Peak Output Current
- Output Voltages Balanced Within 1% (XR-1568)
- 0.06% Line and Load Regulation
- Low Stand-By Current
- Output Externally Adjustable from ± 8 to ± 20 Volts
- Externally Adjustable Current Limiting
- Remote Sensing

APPLICATIONS

- Main Regulation in Small Instruments
- On-Card Regulation in Analog and Digital Systems
- Point-of-Load Precision Regulation

ABSOLUTE MAXIMUM RATINGS

Power Supply	± 30 Volts
Minimum Short-Circuit Resistance	4.0 Ohms
Load Current, Peak	± 100 mA
Power Dissipation	
Ceramic (N) Package	1.0 Watt
Derate Above +25°C	6.7 mW/°C
Operating Temperature	
XR-1568M	-55°C to +125°C
XR-1568/XR-1468C	0°C to +70°C
Storage Temperature	-65°C to +150°C

FUNCTIONAL BLOCK DIAGRAM

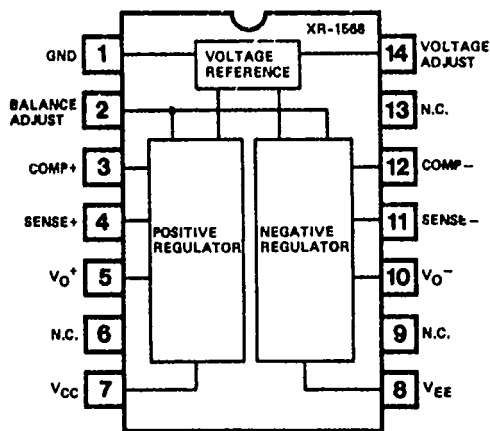

ORDERING INFORMATION

Part Number	Temperature	Output Offset	Package
XR-1568M	-55°C to +125°C	± 150 mV max	Ceramic
XR-1568N	0°C to +70°C	± 150 mV max	Ceramic
XR-1468CN	0°C to +70°C	± 300 mV max	Ceramic

SYSTEM DESCRIPTION

The XR-1468/1568 is a dual polarity tracking voltage regulator combining two separate regulators with a common reference element in a single monolithic circuit, thus providing a very close balance between the positive and negative output voltages. Outputs are internally set to ± 15 Volts but can be externally adjusted between ± 8.0 to ± 20 Volts with a single control. The circuit features ± 100 mA output current, with externally adjustable current limiting, and provision for remote voltage sensing.