

42109

**OPERATIONAL AMPLIFIER
DSCC DWG #5962-9065901**

Replacement for PA12

Mii

**HYBRID MICROELECTRONICS
PRODUCTS DIVISION**

Features:

- Wide Supply Voltage Range (± 10 to ± 50 Volts)
- High Output Current (15A Peak)
- Small Size (TO-3, 8 Pins)
- Low Cost

Applications:

- Motor, Valve and Actuator Control
- Magnetic Deflection Circuits
- Audio Amplifiers
- Power Transducers

DESCRIPTION

The 42109, DSCC drawing #5962-9065901 is a high power, high voltage, high current, power operational amplifier and is a replacement for the PA12. The Op Amp is designed to drive capacitive, inductive and sensitive loads. The device is complete with current limiting using external resistors, and fabricated using hybrid techniques to maximize reliability, minimize size and give top performance.

ABSOLUTE MAXIMUM RATINGS

Power Supply Voltage (V_{CC})	$\pm 50VDC$
Differential Input Voltage	$\pm V_{CC} - 3V$
Common Mode Input Voltage	$\pm V_{CC}$
Operating Temperature Range (case)	$-55^{\circ}C$ to $+125^{\circ}C$
Storage Temperature Range	$-65^{\circ}C$ to $+150^{\circ}C$
Output Current	15A Peak
Power Dissipation at $T_C = 25^{\circ}C$	125W
Lead Temperature (Soldering < 10 sec).....	$+300^{\circ}C$

Micropac Industries cannot assume any responsibility for any circuits shown or represent that they are free from patent infringement. **Micropac** reserves the right to make changes at any time in order to improve design and to supply the best product possible.

Mechanical Configuration

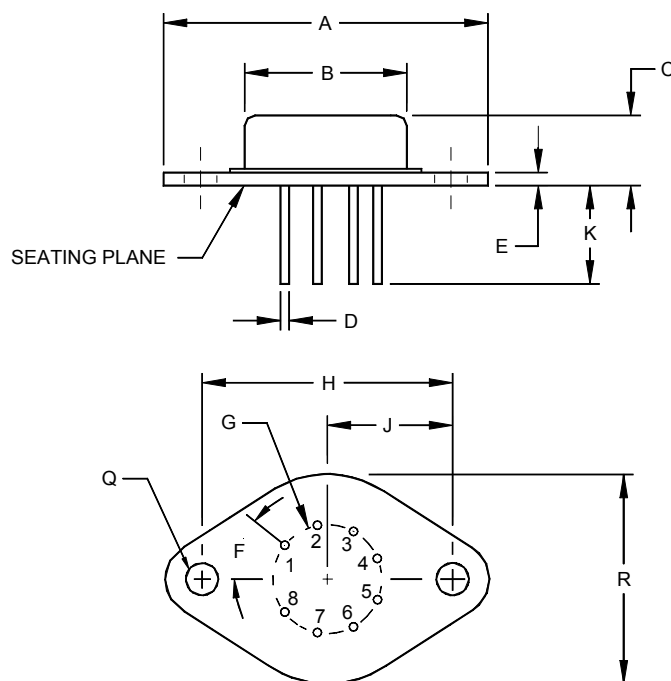

Note: Leads in true position with 0.010" (0.25mm) R at MMC at seating plane
Pin Numbers shown for reference only. Numbers may not be marked on package.

DIM	INCHES		MILLIMETERS	
	MIN	MAX	MIN	MAX
A	1.510	1.550	38.35	39.37
B	0.760	0.780	19.30	19.81
C		0.290		7.37
D	0.97	1.07	0.038	0.042
E	0.080	0.100	2.03	2.54
F	40° BASIC		40° BASIC	
G	.500 BASIC		12.7 BASIC	
H	1.186 BASIC		30.12 BASIC	
J	.593 BASIC		15.06 BASIC	
K	0.460	0.500	11.68	12.70
Q	0.151	0.161	3.84	4.09
R	0.990	1.010	25.15	25.65

ELECTRICAL CONNECTIONS	
Pin 1	Output 1
Pin 2	CL ⁺
Pin 3	+V _C
Pin 4	+IN
Pin 5	-IN
Pin 6	-V _C
Pin 7	N.C.
Pin 8	CL-

Micropac Industries cannot assume any responsibility for any circuits shown or represent that they are free from patent infringement.
Micropac reserves the right to make changes at any time in order to improve design and to supply the best product possible.

ELECTRICAL CHARACTERISTICS $T_C = 25^\circ\text{C}$, $V_{CC} = \pm 36\text{VDC}$

unless otherwise specified

PARAMETER	SYMBOL	TEST CONDITIONS	MIN	TYP	MAX	UNIT
Input Offset Voltage	V_{IO}	$T_C = 25^\circ\text{C}$ $T_C = -55^\circ\text{C to } +125^\circ\text{C}$			± 6 ± 65	mV $\mu\text{V}/^\circ\text{C}$
Input Offset Voltage vs Supply	$V_{IO}(V_{CC})$				± 200	$\mu\text{V}/\text{V}$
Input Offset Voltage vs Power	$V_{IO}(P)$			± 20		$\mu\text{V}/\text{W}$
Input Bias Current	I_{B+}, I_{B-}	$T_C = 25^\circ\text{C}$ $T_C = -55^\circ\text{C to } +125^\circ\text{C}$			30 400	nA $\text{nA}/^\circ\text{C}$
Input Bias Current vs Supply	$I_B(V_{CC})$	$T_C = 25^\circ\text{C}$		10		PAV
Input Offset Current	I_{IO}	$T_C = 25^\circ\text{C}$ $T_C = -55^\circ\text{C to } +125^\circ\text{C}$		50	30	pA $\text{nA}/^\circ\text{C}$
Input Impedance	R_{IN}	$T_C = 25^\circ\text{C}$		200		$\text{M}\Omega$
Gain Bandwidth Product @ 1 MHz	G_B	$T_C = 25^\circ\text{C}$ $R_L = 8\Omega$		4		MHz
Power Bandwidth	P_B	$R_L = 8\Omega$	13	20		kHz
Phase Margin	I_m	$-55^\circ\text{C to } +125^\circ\text{C}$ $R_L = 8\Omega$		45		Degree
Common Mode Rejection Ratio	CMRR	$V_{ICM} = \pm 9\text{V}$ $V_{CC} = \pm 15\text{V}$, $R_L = 500$	74			dB
Output Voltage/ Voltage Swing	V_O	$I_O = 10\text{A}$, $V_{CC} = \pm 16\text{V}$ $R_L = 1\Omega$	± 10			V
Output Voltage Swing	V_O V_O	$T_C = 25^\circ\text{C}$, $I_O = 5\text{A}$ $I_O = 80\text{mA Full Temp Range}$	$\pm V_{CC} - 5$			V
Open Loop Gain	A_V	$R_L = 250\Omega$, $f = 10\text{HZ}$		94		dB
Slew Rate @ 20% of V_O	SR	$R_L = 100\Omega$, $R_{CL} = 0$ $V_{IN} = 40\text{ V}_{P-P}$ square wave $f = 1\text{kHz}$, $V_O = 40\text{ V}_{P-P}$	2.5	4.0		$\text{V}/\mu\text{S}$
Power Supply	V_{CC}	$-55^\circ\text{C to } +125^\circ\text{C}$	± 10	± 40	± 50	V
Quiescent Current	I_S	$V_{IN} = 1\text{G} = 100$ $T_C = 25^\circ\text{C}$		25	50	mA

Micropac Industries cannot assume any responsibility for any circuits shown or represent that they are free from patent infringement. Micropac reserves the right to make changes at any time in order to improve design and to supply the best product possible.