

Features:

- Design Tested to 100 krad(Si) Total Dose
- Hermetically Sealed in Metal Package
- Performance over -55°C to +125°C
- Wide Supply Voltage Range
- High Output Current
- Short Circuit Protection

Applications:

- Satellite/Space systems
- Military/High Reliability Systems
- Programmable Power Supplies
- Solenoid Driver
- Servo Motor Amplifier
- Synchro Power Amplifier

DESCRIPTION

The 42142 is a power operational amplifier designed for military and space applications where radiation tolerance is required. Utilizing multi-chip hybrid construction, the 42142 power operational amplifier combines 10A load current capability with the convenience of a monolithic operational amplifier. Output current limiting is provided using external resistors. The 42142 power operational amplifier is supplied in an 8-pin hermetic flat package. This design has demonstrated it will function with minimal degradation after exposure to 100 krad(Si) total dose. This device is available as COTS, or screened to MIL-PRF-38534, Table C-IX, Class H or custom screening. Lead options support both through-hole and surface-mount assembly.

ABSOLUTE MAXIMUM RATINGS:

Supply Voltage ($\pm V_S$)	± 22 V
Input Voltage ⁽¹⁾	± 22 V
Differential Input Voltage ⁽²⁾	± 0.7 V
Peak Output Current ⁽³⁾	10 A
Storage Temperature Range	-65°C to +150°C
Operating Junction Temperature	-55°C to +150°C
Lead Solder Temperature for 10 seconds	300°C
Power Dissipation ⁽⁴⁾	95 W
Linear Derating Factor	0.76 W/°C

WEIGHT: 15.2 grams (typical)

RECOMMENDED OPERATING CONDITIONS:

Parameter	Symbol	Min.	Max.	Units
Supply Voltage	$\pm V_S$	8	20	VDC
Ambient Temperature	T_A	-55	125	°C

Micropac Industries cannot assume any responsibility for any circuits shown or represent that they are free from patent infringement. **Micropac** reserves the right to make changes at any time in order to improve design and to supply the best product possible.

ELECTRICAL SPECIFICATIONS (Pre-Irradiation) $V_S = \pm 15\text{ V}$, $T_C = -55^\circ\text{C}$ to $+125^\circ\text{C}$ unless otherwise specified

Parameter	Symbol	Min.	Typ.*	Max.	Units	Test Conditions
Input Offset Voltage	V_{OS}	—	± 25	± 200	μV	
Input Offset Voltage Drift	—	—	—	± 5	$\mu\text{V}/^\circ\text{C}$	
Input Bias Current	I_{B+}, I_{B-}	—	± 15	± 80	nA	
Input Offset Current	I_{OS}	—	10	75	nA	
DC Open Loop Gain	A_{VOL}	100	126	—	dB	$R_L > 2\text{ k}\Omega$, $V_O = \pm 10\text{V}$
Common-Mode Input Voltage Range	V_{CM}	± 10.3	± 12.3	—	V	
Common-Mode Rejection Ratio	CMRR	100	—	—	dB	$V_{CM} = \pm 9\text{ VDC}$ $R_L = 10\text{ k}\Omega$
Gain Bandwidth Product ⁽⁵⁾	GBW	—	1	—	MHz	$R_L = 10\text{ k}\Omega$
Phase Margin ⁽⁵⁾	Φ_M	—	45	—	degree	(small signal)
Slew Rate	SR	2	—	—	V/ μs	$R_L = 100\ \Omega$ $R_{CL} = 0\ \Omega$
Output Voltage Swing	V_O	± 12 ± 10	—	—	V	$R_L = 10\text{ k}\Omega$ $R_L = 1\ \Omega$
Quiescent Current	I_Q	—	4	7	mA	$R_L = \infty\ \Omega$
Thermal Resistance	θ_{JA}	—	30	—	$^\circ\text{C}/\text{W}$	TO-3 package

* All typical values are at $T_C = 25^\circ\text{C}$ **Notes:**

1. For V_S less than $\pm 22\text{ V}$, the input voltage is not to exceed $\pm V_S$.
2. Input current must not exceed 25 mA
3. It is recommended that external current limiting resistors ($\pm R_{CL} \geq 0.068\ \Omega$) be used to ensure that 10 A is not exceeded. See Figures 1, 2 and 4 for R_{CL} application information.
4. Case Temperature $T_C = 25^\circ\text{C}$ (see Figure 3).
5. Guaranteed by design.

Micropac Industries cannot assume any responsibility for any circuits shown or represent that they are free from patent infringement. Micropac reserves the right to make changes at any time in order to improve design and to supply the best product possible.

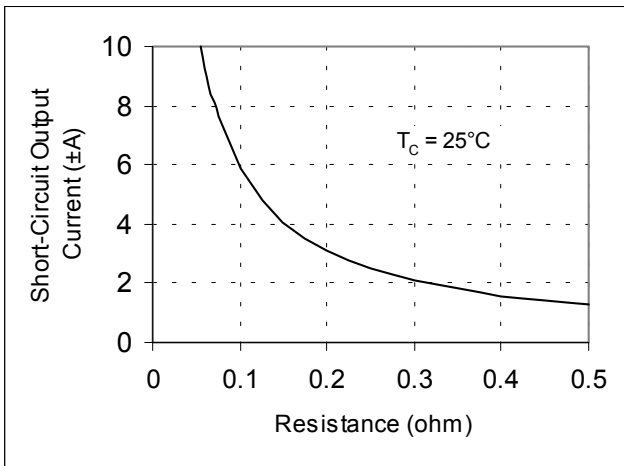

Figure 1. Typical Short-Circuit Output Current Case vs. Current Limiting Resistors ($\pm R_{CL}$)

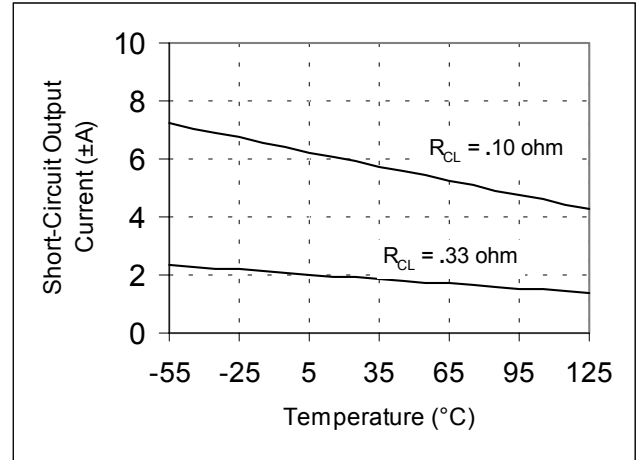

Figure 2. Short-Circuit Output Current vs. Temperature (typical data).

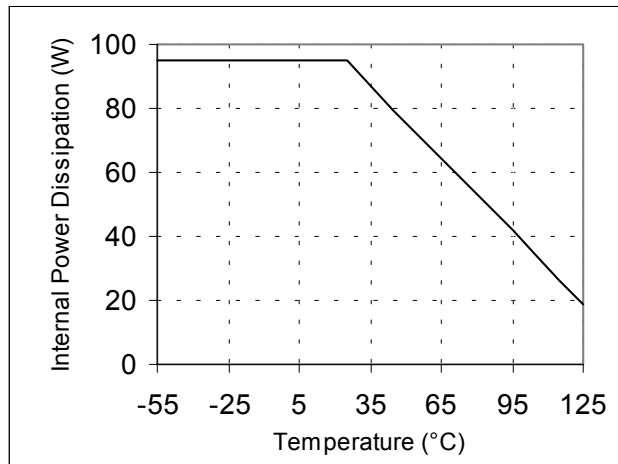

Figure 3. Maximum Average Power Dissipation vs. Case Temperature (TO-3 package)

Micropac Industries cannot assume any responsibility for any circuits shown or represent that they are free from patent infringement. Micropac reserves the right to make changes at any time in order to improve design and to supply the best product possible.

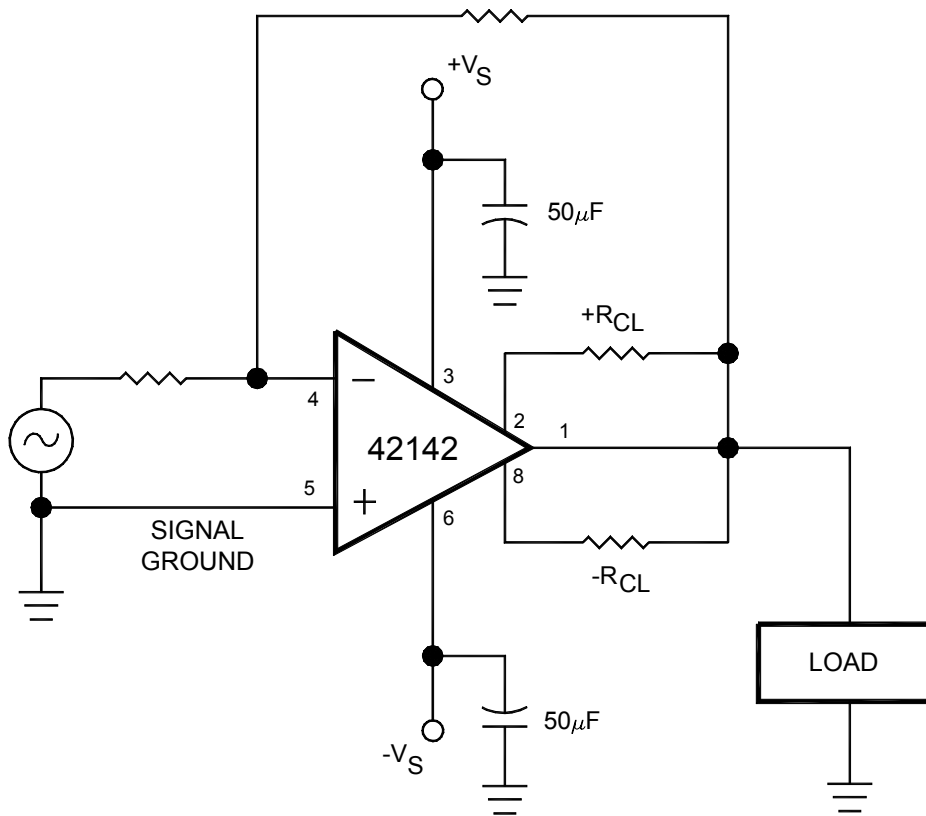

Figure 4. Application Information

Controlling the short circuit current to the minimum necessary for a given application maximizes device protection and reliability.

Approximate values for the current limiting resistors can be determined from the equation:

$$R_{CL} = (0.65/I_{SC} - 0.01) \Omega$$

where I_{SC} is the short circuit current limit in amperes at $T_C = 25^\circ\text{C}$.

Current limits for positive and negative load currents can be set independently.

Current limiting resistors carry the full output current, therefore the short circuit current limit should be used in determining resistor wattage. Lead lengths of the limiting resistors should be minimized and highly inductive resistor types should be avoided.

Large bypass capacitors (50 μF) are recommended across the power supply terminals if the application requires large output current transients. Care should be taken to keep the power supply ground currents from flowing through the signal ground path.

Micropac Industries cannot assume any responsibility for any circuits shown or represent that they are free from patent infringement. Micropac reserves the right to make changes at any time in order to improve design and to supply the best product possible.

TOTAL DOSE TEST RESULTS

Disclaimer: The data of 4 representative units irradiated in Cobalt-60 chamber is only typical of one lot of operational amplifiers. Micropac does not guarantee performance of its Operational Amplifier to these radiation levels. Individual lots have to be screened to guarantee the performance.

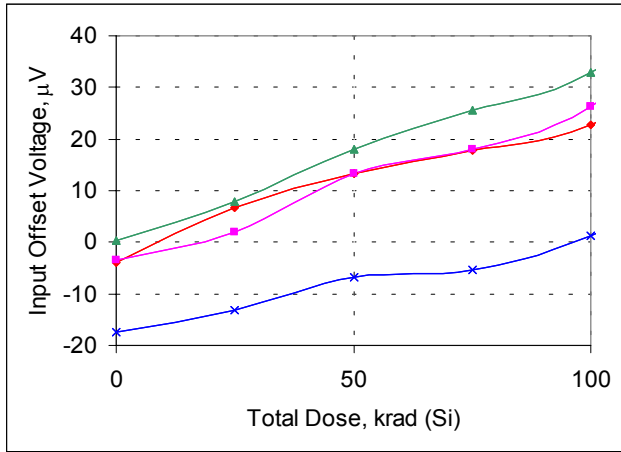

Figure 5. Input Offset Voltage vs Total Dose

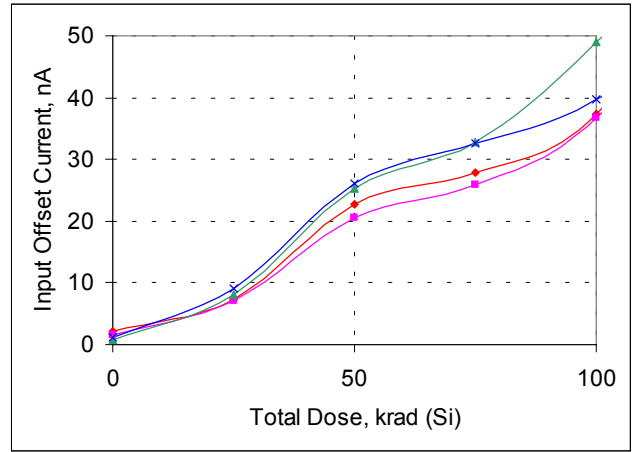

Figure 6. Input Offset Current vs Total Dose

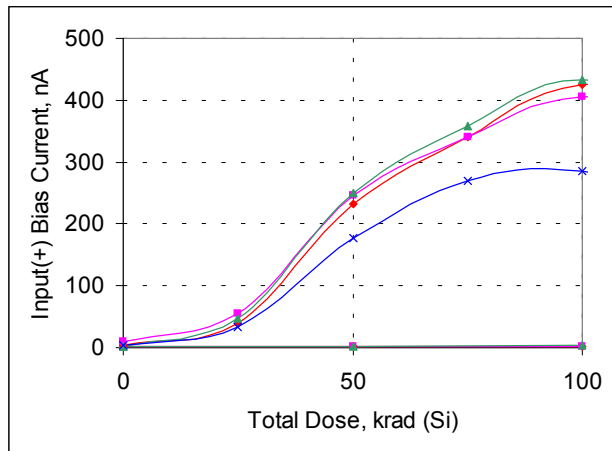

Figure 7. Input (+) Bias Current vs Total Dose

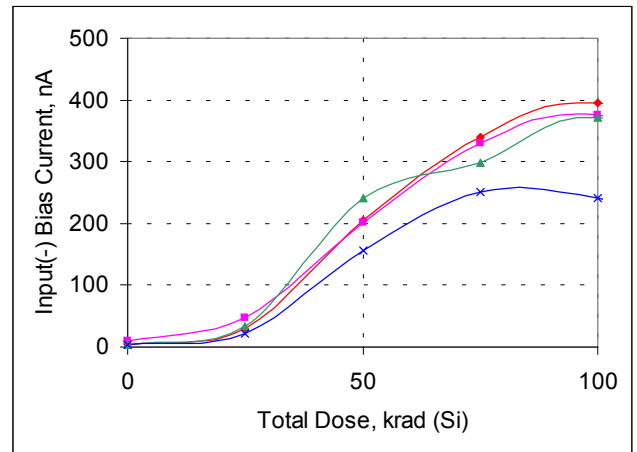

Figure 8. Input (-) Bias Current vs Total Dose

Micropac Industries cannot assume any responsibility for any circuits shown or represent that they are free from patent infringement. Micropac reserves the right to make changes at any time in order to improve design and to supply the best product possible.

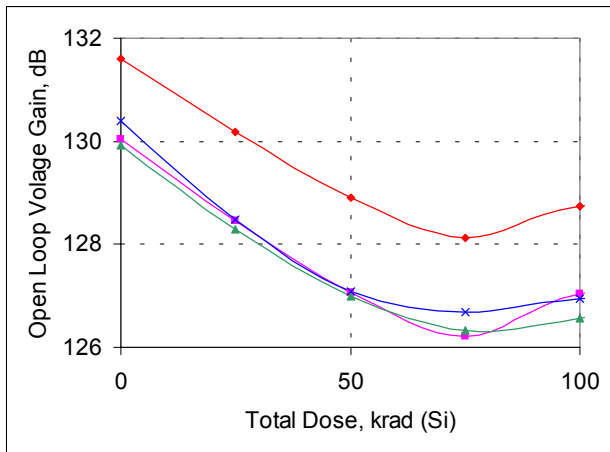

Figure 9. Open Loop Voltage Gain vs Total Dose

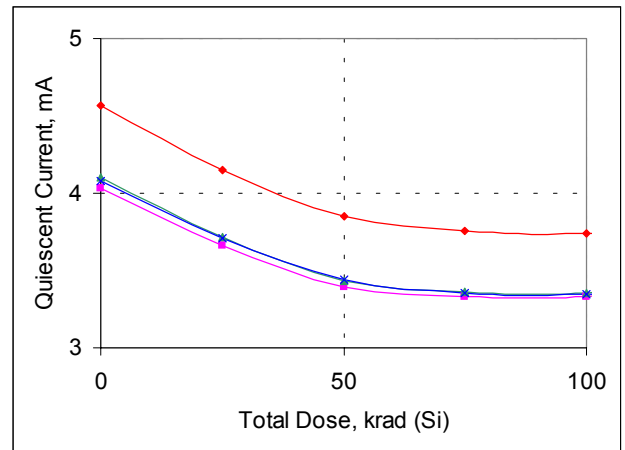
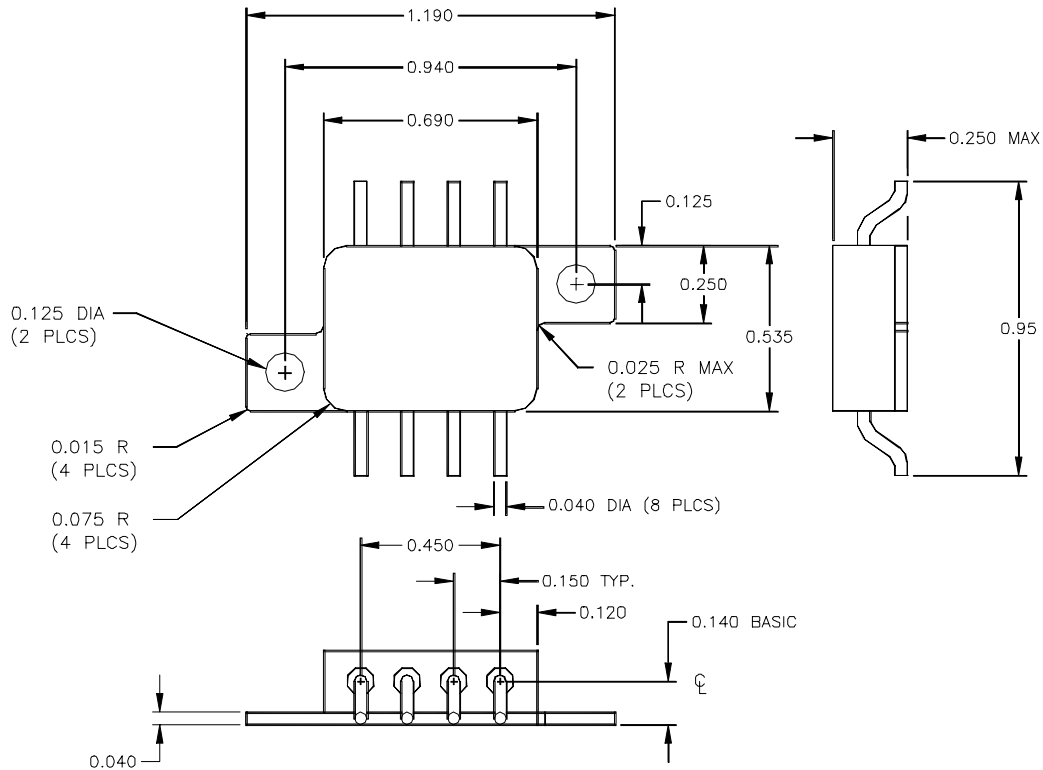

Figure 10. Quiescent Current vs Total Dose

Micropac Industries cannot assume any responsibility for any circuits shown or represent that they are free from patent infringement. Micropac reserves the right to make changes at any time in order to improve design and to supply the best product possible.

CASE OUTLINE



NOTE: Dimensions in inches.

ELECTRICAL CONNECTIONS

- Pin 1+V_S
- Pin 2 -IN
- Pin 3 +IN
- Pin 4 -V_S
- Pin 5 CL-
- Pin 6 OUT
- Pin 7 NC
- Pin 8 CL+

Micropac Industries cannot assume any responsibility for any circuits shown or represent that they are free from patent infringement. **Micropac** reserves the right to make changes at any time in order to improve design and to supply the best product possible.

CASE OUTLINE (FOR ENGINEERING SAMPLES ONLY)

DIM	INCHES		MILLIMETERS	
	MIN	MAX	MIN	MAX
A	1.510	1.550	38.35	39.37
B	.745	.770	18.92	19.56
C	.260	.300	6.60	7.62
D	.038	.042	0.97	1.07
E	.080	.105	2.03	2.67
F	40° BASIC		40° BASIC	
G	.500 BASIC		12.7 BASIC	
H	1.186 BASIC		30.12 BASIC	
J	.583 BASIC		15.08 BASIC	
K	.400	.500	10.16	12.70
Q	.151	.161	3.84	4.09
R	.980	1.020	24.89	25.91

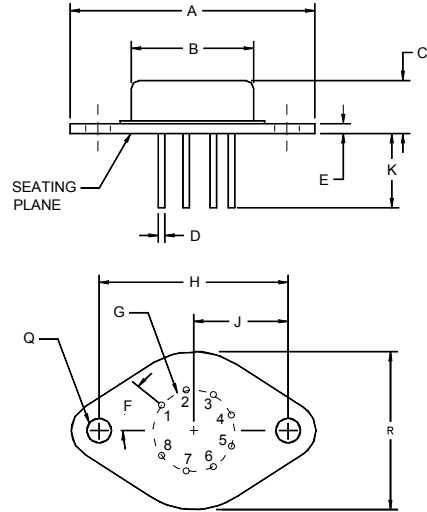

NOTE: Leads in true position with 0.010" (0.25mm) R at MMC at seating plane.
 Pin numbers shown for reference only. Numbers may not be marked on package.

ELECTRICAL CONNECTIONS

- Pin 1 Output
- Pin 2 CL+
- Pin 3 +V_S
- Pin 4 +IN
- Pin 5 -IN
- Pin 6 -V_S
- Pin 7 N.C.
- Pin 8 CL-

NOTE: The engineering samples could be provided in TO-3 package with the pin functions as shown above.

Micropac Industries cannot assume any responsibility for any circuits shown or represent that they are free from patent infringement. Micropac reserves the right to make changes at any time in order to improve design and to supply the best product possible.