



website:<http://biz.LGservice.com>  
e-mail:<http://www.LGservice.com/techsup.html>

# LCD TV

# SERVICE MANUAL

CHASSIS : LP62C

FACTORY MODEL : 37LC2R-TH / 42LC2R-TH

**MODEL : 37LC2R / 42LC2R**

## CAUTION

BEFORE SERVICING THE CHASSIS,  
READ THE SAFETY PRECAUTIONS IN THIS MANUAL.

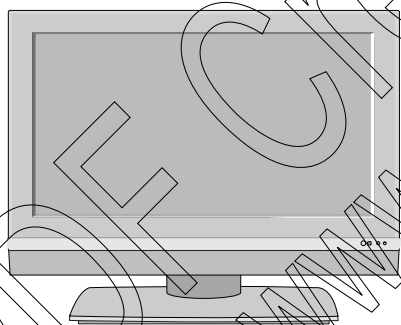

# CONTENTS

<b>CONTENTS .....</b>	<b>2</b>
<b>SAFETY PRECAUTIONS .....</b>	<b>3</b>
<b>SPECIFICATION .....</b>	<b>6</b>
<b>ADJUSTMENT INSTRUCTION.....</b>	<b>11</b>
<b>TROUBLE SHOOTING .....</b>	<b>16</b>
<b>BLOCK DIAGRAM.....</b>	<b>23</b>
<b>EXPLODED VIEW .....</b>	<b>25</b>
<b>REPLACEMENT PARTS LIST .....</b>	<b>28</b>
<b>SVC. SHEET .....</b>	<b></b>

PDF Create & Trial  
www.nuance.com

# SAFETY PRECAUTIONS

## IMPORTANT SAFETY NOTICE

Many electrical and mechanical parts in this chassis have special safety-related characteristics. These parts are identified by  $\triangle$  in the Schematic Diagram and Replacement Parts List.

It is essential that these special safety parts should be replaced with the same components as recommended in this manual to prevent X-RADIATION, Shock, Fire, or other Hazards.

Do not modify the original design without permission of manufacturer.

### General Guidance

An **isolation Transformer should always be used** during the servicing of a receiver whose chassis is not isolated from the AC power line. Use a transformer of adequate power rating as this protects the technician from accidents resulting in personal injury from electrical shocks.

It will also protect the receiver and its components from being damaged by accidental shorts of the circuitry that may be inadvertently introduced during the service operation.

If any fuse (or Fusible Resistor) in this TV receiver is blown, replace it with the specified.

When replacing a high wattage resistor (Oxide Metal Film Resistor, over 1W), keep the resistor 10mm away from PCB.

Keep wires away from high voltage or high temperature parts.

### X-RAY Radiation

#### Warning:

The source of X-RAY RADIATION in this TV receiver is the High Voltage Section and the LCD PANEL.

For continued X-RAY RADIATION protection, the replacement panel must be the same type panel as specified in the Replacement Parts List.

To determine the presence of high voltage, use an accurate high impedance HV meter.

Adjust brightness, color, contrast controls to minimum.

Measure the high voltage.

The meter reading should indicate

$23.5 \pm 1.5KV$ : 14-19 inch,  $26 \pm 1.5KV$ : 19-21 inch,

$29.0 \pm 1.5KV$ : 25-29 inch,  $30.0 \pm 1.5KV$ : 32 inch

If the meter indication is out of tolerance, immediate service and correction is required to prevent the possibility of premature component failure.

### Before returning the receiver to the customer,

always perform an **AC leakage current check** on the exposed metallic parts of the cabinet, such as antennas, terminals, etc., to be sure the set is safe to operate without damage of electrical shock.

#### Leakage Current Cold Check (Antenna Cold Check)

With the instrument AC plug removed from AC source, connect an electrical jumper across the two AC plug prongs. Place the AC switch in the on position, connect one lead of ohm-meter to the AC plug prongs tied together and touch other ohm-meter lead in turn to each exposed metallic parts such as antenna terminals, phone jacks, etc.

If the exposed metallic part has a return path to the chassis, the measured resistance should be between  $1M\Omega$  and  $5.2M\Omega$ .

When the exposed metal has no return path to the chassis the reading must be infinite.

An other abnormality exists that must be corrected before the receiver is returned to the customer.

#### Leakage Current Hot Check (See below Figure)

Plug the AC cord directly into the AC outlet.

**Do not use a line Isolation Transformer during this check.**

Connect 1.5K/10watt resistor in parallel with a 0.15uF capacitor between a known good earth ground (Water Pipe, Conduit, etc.) and the exposed metallic parts.

Measure the AC voltage across the resistor using AC voltmeter with 1000 ohms/volt or more sensitivity.

Reverse plug the AC cord into the AC outlet and repeat AC voltage measurements for each exposed metallic part. Any voltage measured must not exceed 0.75 volt RMS which corresponds to 0.5mA.

In case any measurement is out of the limits specified, there is possibility of shock hazard and the set must be checked and repaired before it is returned to the customer.

#### Leakage Current Hot Check circuit

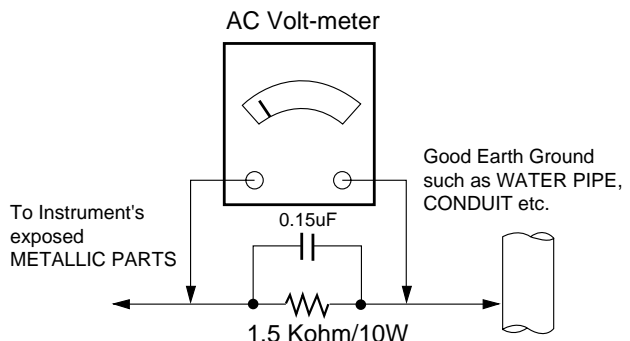

# SERVICING PRECAUTIONS

**CAUTION:** Before servicing receivers covered by this service manual and its supplements and addenda, read and follow the *SAFETY PRECAUTIONS* on page 3 of this publication.

**NOTE:** If unforeseen circumstances create conflict between the following servicing precautions and any of the safety precautions on page 3 of this publication, always follow the safety precautions. Remember: Safety First.

## General Servicing Precautions

1. Always unplug the receiver AC power cord from the AC power source before;
  - a. Removing or reinstalling any component, circuit board module or any other receiver assembly.
  - b. Disconnecting or reconnecting any receiver electrical plug or other electrical connection.
  - c. Connecting a test substitute in parallel with an electrolytic capacitor in the receiver.**CAUTION:** A wrong part substitution or incorrect polarity installation of electrolytic capacitors may result in an explosion hazard.

2. Test high voltage only by measuring it with an appropriate high voltage meter or other voltage measuring device (DVM, FETVOM, etc) equipped with a suitable high voltage probe. Do not test high voltage by "drawing an arc".

3. Do not spray chemicals on or near this receiver or any of its assemblies.

4. Unless specified otherwise in this service manual, clean electrical contacts only by applying the following mixture to the contacts with a pipe cleaner, cotton-tipped stick or comparable non-abrasive applicator; 10% (by volume) Acetone and 90% (by volume) isopropyl alcohol (90%-99% strength)

**CAUTION:** This is a flammable mixture.

Unless specified otherwise in this service manual, lubrication of contacts is not required.

5. Do not defeat any plug/socket B+ voltage interlocks with which receivers covered by this service manual might be equipped.
6. Do not apply AC power to this instrument and/or any of its electrical assemblies unless all solid-state device heat sinks are correctly installed.

7. Always connect the test receiver ground lead to the receiver chassis ground before connecting the test receiver positive lead.

Always remove the test receiver ground lead last.

8. Use with this receiver only the test fixtures specified in this service manual.

**CAUTION:** Do not connect the test fixture ground strap to any heat sink in this receiver.

## Electrostatically Sensitive (ES) Devices

Some semiconductor (solid-state) devices can be damaged easily by static electricity. Such components commonly are called *Electrostatically Sensitive (ES) Devices*. Examples of typical ES devices are integrated circuits and some field-effect transistors and semiconductor "chip" components. The following techniques should be used to help reduce the incidence of component damage caused by static by static electricity.

1. Immediately before handling any semiconductor component or semiconductor-equipped assembly, drain off any electrostatic charge on your body by touching a known earth ground. Alternatively, obtain and wear a commercially available discharging wrist strap device, which should be removed to prevent potential shock reasons prior to applying power to the

unit under test.

2. After removing an electrical assembly equipped with ES devices, place the assembly on a conductive surface such as aluminum foil, to prevent electrostatic charge buildup or exposure of the assembly.
3. Use only a grounded-tip soldering iron to solder or unsolder ES devices.
4. Use only an anti-static type solder removal device. Some solder removal devices not classified as "anti-static" can generate electrical charges sufficient to damage ES devices.
5. Do not use freon-propelled chemicals. These can generate electrical charges sufficient to damage ES devices.
6. Do not remove a replacement ES device from its protective package until immediately before you are ready to install it. (Most replacement ES devices are packaged with leads electrically shorted together by conductive foam, aluminum foil or comparable conductive material.)
7. Immediately before removing the protective material from the leads of a replacement ES device, touch the protective material to the chassis or circuit assembly into which the device will be installed.  
**CAUTION:** Be sure no power is applied to the chassis or circuit, and observe all other safety precautions.
8. Minimize bodily motions when handling unpackaged replacement ES devices. (Otherwise harmless motion such as the brushing together of your clothes fabric or the lifting of your foot from a carpeted floor can generate static electricity sufficient to damage an ES device.)

## General Soldering Guidelines

1. Use a grounded-tip, low-wattage soldering iron and appropriate tip size and shape that will maintain tip temperature within the range of 500 °F to 600 °F.
2. Use an appropriate gauge of RMA resin-core solder composed of 60 parts tin/40 parts lead.
3. Keep the soldering iron tip clean and well tinned.
4. Thoroughly clean the surfaces to be soldered. Use a mall wire-bristle (0.5 inch, or 1.25cm) brush with a metal handle. Do not use freon-propelled spray-on cleaners.
5. Use the following unsoldering technique
  - a. Allow the soldering iron tip to reach normal temperature. (500 °F to 600 °F)
  - b. Heat the component lead until the solder melts.
  - c. Quickly draw the melted solder with an anti-static, suction-type solder removal device or with solder braid.  
**CAUTION:** Work quickly to avoid overheating the circuitboard printed foil.
6. Use the following soldering technique.
  - a. Allow the soldering iron tip to reach a normal temperature (500 °F to 600 °F)
  - b. First, hold the soldering iron tip and solder the strand against the component lead until the solder melts.
  - c. Quickly move the soldering iron tip to the junction of the component lead and the printed circuit foil, and hold it there only until the solder flows onto and around both the component lead and the foil.  
**CAUTION:** Work quickly to avoid overheating the circuit board printed foil.
  - d. Closely inspect the solder area and remove any excess or splashed solder with a small wire-bristle brush.

## IC Remove/Replacement

Some chassis circuit boards have slotted holes (oblong) through which the IC leads are inserted and then bent flat against the circuit foil. When holes are the slotted type, the following technique should be used to remove and replace the IC. When working with boards using the familiar round hole, use the standard technique as outlined in paragraphs 5 and 6 above.

### Removal

1. Desolder and straighten each IC lead in one operation by gently prying up on the lead with the soldering iron tip as the solder melts.
2. Draw away the melted solder with an anti-static suction-type solder removal device (or with solder braid) before removing the IC.

### Replacement

1. Carefully insert the replacement IC in the circuit board.
2. Carefully bend each IC lead against the circuit foil pad and solder it.
3. Clean the soldered areas with a small wire-bristle brush. (It is not necessary to reapply acrylic coating to the areas).

## "Small-Signal" Discrete Transistor

### Removal/Replacement

1. Remove the defective transistor by clipping its leads as close as possible to the component body.
2. Bend into a "U" shape the end of each of three leads remaining on the circuit board.
3. Bend into a "U" shape the replacement transistor leads.
4. Connect the replacement transistor leads to the corresponding leads extending from the circuit board and crimp the "U" with long nose pliers to insure metal to metal contact then solder each connection.

## Power Output, Transistor Device

### Removal/Replacement

1. Heat and remove all solder from around the transistor leads.
2. Remove the heat sink mounting screw (if so equipped).
3. Carefully remove the transistor from the heat sink of the circuit board.
4. Insert new transistor in the circuit board.
5. Solder each transistor lead, and clip off excess lead.
6. Replace heat sink.

## Diode Removal/Replacement

1. Remove defective diode by clipping its leads as close as possible to diode body.
2. Bend the two remaining leads perpendicularly to the circuit board.
3. Observing diode polarity, wrap each lead of the new diode around the corresponding lead on the circuit board.
4. Securely crimp each connection and solder it.
5. Inspect (on the circuit board copper side) the solder joints of the two "original" leads. If they are not shiny, reheat them and if necessary, apply additional solder.

## Fuse and Conventional Resistor

### Removal/Replacement

1. Clip each fuse or resistor lead at top of the circuit board hollow stake.
2. Securely crimp the leads of replacement component around notch at stake top.
3. Solder the connections.

**CAUTION:** Maintain original spacing between the replaced component and adjacent components and the circuit board to prevent excessive component temperatures.

## Circuit Board Foil Repair

Excessive heat applied to the copper foil of any printed circuit board will weaken the adhesive that bonds the foil to the circuit board causing the foil to separate from or "lift-off" the board. The following guidelines and procedures should be followed whenever this condition is encountered.

### At IC Connections

To repair a defective copper pattern at IC connections use the following procedure to install a jumper wire on the copper pattern side of the circuit board. (Use this technique only on IC connections).

1. Carefully remove the damaged copper pattern with a sharp knife. (Remove only as much copper as absolutely necessary).
2. Carefully scratch away the solder resist and acrylic coating (if used) from the end of the remaining copper pattern.
3. Bend a small "U" in one end of a small gauge jumper wire and carefully crimp it around the IC pin. Solder the IC connection.
4. Route the jumper wire along the path of the out-away copper pattern and let it overlap the previously scraped end of the good copper pattern. Solder the overlapped area and clip off any excess jumper wire.

### At Other Connections

Use the following technique to repair the defective copper pattern at connections other than IC Pins. This technique involves the installation of a jumper wire on the component side of the circuit board.

1. Remove the defective copper pattern with a sharp knife. Remove at least 1/4 inch of copper, to ensure that a hazardous condition will not exist if the jumper wire opens.
  2. Trace along the copper pattern from both sides of the pattern break and locate the nearest component that is directly connected to the affected copper pattern.
  3. Connect insulated 20-gauge jumper wire from the lead of the nearest component on one side of the pattern break to the lead of the nearest component on the other side. Carefully crimp and solder the connections.
- CAUTION:** Be sure the insulated jumper wire is dressed so the it does not touch components or sharp edges.

# SPECIFICATION

NOTE : Specifications and others are subject to change without notice for improvement.

## 1. Application range

This specification is applied to LP62C chassis.

## 2. Requirement for Test

Testing for standard of each part must be followed in below condition.

- (1) Temperature : 25°C±5°C(77±9°F), CST : 40±5
- (2) Humidity : 65%±10%
- (3) Power : Standard input voltage (AC 100-240V, 50/60Hz)  
\*Standard Voltage of each products is marked by models
- (4) Specification and performance of each parts are followed each drawing and specification by part number in accordance with BOM.
- (5) The receiver must be operated for about 20 minutes prior to the adjustment.

## 3. Test method

- 3.1 Performance : LGE TV test method followed
- 3.2 Demanded other specification  
Safety : CE, IEC Specification  
EMC : CE, IEC

## 4. General TV Specification

No	Item	Specification	Remark
1.	Video input applicable system	PAL-D/K, B/G, I, NTSC-M, SECAM, NTSC 4.43	
2.	Receivable Broadcasting System	1) PAL/SECAM BG	
		2) PAL/SECAM DK	
		3) PAL I/I	
		4) SECAM L/L'	only ZH
		5) PAL-N/M	
		6) NTSC M	only TH
3.	RF Input Channel	VHF : E2 ~ E12	PAL
		UHF : E21 ~ E69	
		CATV : S1 ~ S20	
		HYPER : S21 ~ S47	
		L/L' : B, C, D	FRANCE
		VHF : 2~13	NTSC
		UHF : 14~69	
		CATV : 1~125	
4.	Input Voltage	AC 100 ~ 240 V/50Hz, 60Hz	
5.	Market	Worldwide	
6.	Active Screen Size	940.3 mm(diagonal)	37.02 inches
		1067.308 mm (diagonal)	42.02 inches
7.	Tuning System	FVS 100 program FS	
8.	Operating Environment	1) Temp : 0 ~ 40 deg 2) Humidity : 10 ~ 90 %RH	
9.	Storage Environment	1) Temp : -20 ~ 50 deg 2) Humidity : 10 ~ 90 %RH	
10.	Display	LCD Module	32"/42" : LPL
			37" : AUO, LPL

## 5. General Specification

No	Item	Specification	Remark		
1	Panel	37", 42" TFT WXGA LCD			
2	Frequency range	H : 31 ~ 61KHzV : 56 ~ 75Hz	PC Input		
3	Control Function	1) Contrast/Brightness 2) H-Position / V-Position 3) Tracking : Clock / Phase 4) Auto Configure 5) Reset			
4	Component Jack (480i/576i/480p/576p/720p/1080i)	Y/Pb/Pr : 1EA Y/Pb/Pr : 2EA	ZH TH		
5	Power ON	LED	Power consumption		
		White	≤ 190W(37") ≤ 230W(42")		
	Stand by	RED	≤ 1W		
6	LCD Module	Outline	37"	877.0 x 516.8 x 55.5	(H)mmx(V)mmx(D)mm
		Dimension	42"	1006 x 610 x 56	
		Pixel Pitch	37"	0.200 x 0.600 x RGB	
			42"	0.227 x 0.681 x RGB	
		Pixel Format	1366 x 768 Pixels RGB strip arrangement		
		Coating	Hard coating(3H), Anti-glare treatment of the front polarizer.		
		Back Light	37"	16CCFL	
			42"	20CCFL	

## 6. Set Optical Feature

### 6.1. 37LC2R-TH/42LC2R-TH

No	Parameter	Symbol	Value			Unit	Remark	
			Min	Typ	Max			
1.	Contrast Ratio	CR	37"	800	1200		(*) Normal Mode - 100IRE Full white window pattern - APC : Clear (Dynamic)	
			42"	700	1000			
2.	Surface Luminance, white	LWH	360	450		Cd/m <sup>2</sup>	(*) Normal Mode - 100IRE Full white window pattern - APC : Clear (Dynamic)	
3.	White Coordinate	Normal	X axis	0.280	0.283	0.286		- 85IRE Full White Pattern - APC : Standard
			Y axis	0.295	0.298	0.301		
		Cool	X axis	0.271	0.274	0.277		
			Y axis	0.283	0.286	0.289		
		Warm	X axis	0.300	0.303	0.306		
			Y axis	0.316	0.319	0.322		
4.	Color Temperature	Normal	8300	9300	10300		- 85IRE Full White Pattern - APC : Standard	
		Warm	6200	7200	8200			
		Cool	10000	11000	12000			
5.	Color pull in Range	PAL	-500		+500	Hz		
		NTSC	-500		+500	Hz		
6.	Color killer Sensitivity				-80	dBm		

## 6.2. 37LC2R-TH/37LC2R-ZH(Only AUO Module)

No	Parameter	Symbol		Value			Unit	Remark
				Min	Typ	Max		
1.	Contrast Ratio	CR	32", 37"	800	1200			(*) Normal Mode - 100IRE Full white window pattern - APC : Clear (Dynamic)
			42"	700	1000			
2.	Surface Luminance, white	LWH	360	450			Cd/m <sup>2</sup>	(*) Normal Mode - 100IRE Full white window pattern - APC : Clear (Dynamic)
3.	White Coordinate	Normal	X axis	0.280	0.283	0.286		- 85IRE Full White Pattern - APC : Standard
			Y axis	0.295	0.298	0.301		
		Cool	X axis	0.271	0.274	0.277		
			Y axis	0.283	0.286	0.289		
		Warm	X axis	0.300	0.303	0.306		
			Y axis	0.316	0.319	0.322		
4.	Color Temperature	Normal		8300	9300	10300		- 85IRE Full White Pattern - APC : Standard
		Warm		6200	7200	8200		
		Cool		10000	11000	12000		
5.	Color pull in Range	PAL		-500		+500	Hz	
		NTSC		-500		+500	Hz	
6.	Color killer Sensitivity					-80	dBm	

## 7. Model Specification

No	Item	Specification			Remark
1.	Market	N-EU			
2.	Broadcasting system	PAL/BG/DK, NTSC-M			
3.	Available Channel	BAND		PAL	NTSC
		VHF/UHF	C1 ~ C69	2-83	
		CATV	S1 ~ S47	1~71	
4.	Receiving system	Upper Heterodyne			
5.	SCART Jack(0EA)	PAL, SECAM, NTSC			
6.	Video Input (2EA)	PAL, SECAM, NTSC			4 System : PAL, SECAM, NTSC, PAL60
7.	S-Video Input (2EA)	PAL, SECAM, NTSC			4 System : PAL, SECAM, NTSC, PAL60
8.	Component Input (1EA)	Y/Cb/Cr, Y/ Pb/Pr			
9.	RGB Input (1EA)	RGB-PC, RGB-DTV			
10.	HDMI Input (2EA)	HDMI-PC HDMI-DTV			
11.	Audio Input (4EA)	PC Audio, Component (1EA), AV (2EA)			L/R Input
12.	Wired Control (1EA)				
13.	Audio variable out(1EA)				



### 8. Component Video Input (Y, PB, PR)

No	Resolution	H-freq(kHz)	V-freq.(kHz)	Pixel clock(MHz)	Remarks
1.	720 x 480	15.73	59.94	13.500	SDTV, DVD 480I(525I)
2.	720 x 480	15.75	60.00	13.514	SDTV, DVD 480I(525I)
3.	720 x 576	15.625	50.00	13.500	SDTV, DVD 576I(625I)
4.	720 x 480	31.47	59.94	27.000	SDTV 480P
5.	720 x 480	31.50	60.00	27.027	SDTV 480P
6.	720 x 576	31.25	50.00	27.000	SDTV 576P
7.	1280 x 720	44.96	59.94	74.176	HDTV 720P
8.	1280 x 720	45.00	60.00	74.250	HDTV 720P
9.	1280 x 720	37.50	50.00	74.25	HDTV 720P 50Hz
10.	1920 x 1080	33.72	59.94	74.176	HDTV 1080I
11.	1920 x 1080	33.75	60.00	74.250	HDTV 1080I
12.	1920 x 1080	28.125	50.00	74.250	HDTV 1080I 50Hz

### 9. RGB Input ( PC )

No	Resolution	H-freq(kHz)	V-freq.(kHz)	Pixel clock(MHz)	Remarks
1	720 x 400	31.469	70.08	28.32	DOS
2.	640 x 480	31.469	59.94	25.17	VESA(VGA)
3	640 x 480	37.500	75.00	31.50	VESA(VGA)
4	800 x 600	37.879	60.31	40.00	VESA(SVGA)
5	800 x 600	46.875	75.00	49.50	VESA(SVGA)
6	832 x 624	49.725	74.55	57.28	Macintosh
7	1024 x 768	48.363	60.00	65.00	VESA(XGA)
8	1024 x 768	56.476	70.06	75.00	VESA(XGA)
9	1024 x 768	60.023	75.02	78.75	VESA(XGA)
10	1280 x 768	47.693	59.99	80.125	WXGA(42XGA,50", 60")
11	1360 x 768	47.700	60.00	84.62	WXGA(42XGA,50", 60")
12	1366 x 768	47.700	60.00	84.62	WXGA(42XGA,50", 60")

### 10. RGB input ( DTV )

No	Resolution	H-freq(kHz)	V-freq.(kHz)	Pixel clock(MHz)	Remarks
1.	720 x 480	31.47	59.94	27.000	SDTV 480P
2.	720 x 480	31.50	60.00	27.027	SDTV 480P
3.	720 x 576	31.25	50.00	27.000	SDTV 576P
4.	1280 x 720	44.96	59.94	74.176	HDTV 720P
5.	1280 x 720	45.00	60.00	74.250	HDTV 720P
6.	1280 x 720	37.50	50.00	74.25	HDTV 720P 50Hz
7.	1920 x 1080	33.72	59.94	74.176	HDTV 1080I
8.	1920 x 1080	33.75	60.00	74.250	HDTV 1080I
9.	1920 x 1080	28.125	50.00	74.250	HDTV 1080I 50Hz

## 11. HDMI Input ( PC )

No	Resolution	H-freq(kHz)	V-freq.(kHz)	Pixel clock(MHz)	Remarks
1	720 x 400	31.469	70.08	28.32	DOS
2	640 x 480	31.469	59.94	25.17	VESA(VGA)
3	640 x 480	37.500	75.00	31.50	VESA(VGA)
4	800 x 600	37.879	60.31	40.00	VESA(SVGA)
5	800 x 600	46.875	75.00	49.50	VESA(SVGA)
6.	832 x 624	49.725	74.55	57.28	Macintosh
7	1024 x 768	48.363	60.00	65.00	VESA(XGA)
8	1024 x 768	56.476	70.06	75.00	VESA(XGA)
9	1024 x 768	60.023	75.02	78.75	VESA(XGA)
10	1280 x 768	47.693	59.99	80.125	WXGA(42XGA,50", 60")
11	1360 x 768	47.700	60.00	84.62	WXGA(42XGA,50", 60")
12	1366 x 768	47.700	60.00	84.62	WXGA(42XGA,50", 60")

## 12. HDMI input ( DTV )

No	Resolution	H-freq(kHz)	V-freq.(kHz)	Pixel clock(MHz)	Remarks
1.	720 x 480	31.47	59.94	27.000	SDTV 480P
2.	720 x 480	31.50	60.00	27.027	SDTV 480P
3.	720 x 576	31.25	50.00	27.000	SDTV 576P
4.	1280 x 720	44.96	59.94	74.176	HDTV 720P
5.	1280 x 720	45.00	60.00	74.250	HDTV 720P
6.	1280 x 720	37.50	50.00	74.25	HDTV 720P 50Hz
7.	1920 x 1080	33.72	59.94	74.176	HDTV 1080I
8.	1920 x 1080	33.75	60.00	74.250	HDTV 1080I
9.	1920 x 1080	28.125	50.00	74.250	HDTV 1080I 50Hz

## 13. Mechanical Specification

### 13.1. 37LC2R

No	Item	Content				Remark	
		Width	Length	Height	Unit		
1.	Product Dimension	Before Packing	944	286	726	mm	SET(With Stand)
		After Packing	1052	383	855	mm	
		Product Weight	Only SET	31			
		With BOX	33.3			Kg	

### 13.2. 42LC2R

No	Item	Content				Remark	
		Width	Length	Height	Unit		
1.	Product Dimension	Before Packing	1054	286	813.5	mm	SET(With Stand)
		After Packing	1166	402	950	mm	
		Product Weight	Only SET	37			
		With BOX	42.3			Kg	

# ADJUSTMENT INSTRUCTION

## 1. Application Range

This spec. sheet is applied to all of the LP62A/B/C chassis(H3-High) manufactured at LG TV Plant all over the world.

## 2. Specification

- 2.1 Because this is not a hot chassis, it is not necessary to use an isolation transformer. However, the use of isolation transformer will help to protect test instruments.
- 2.2 Adjustment must be done in the correct sequence.
- 2.3 The adjustment must be performed at 25± 5°C temperature and 65± 10% relative humidity if there is no specified designation.
- 2.4 The input voltage of the receiver must be kept between 100~220V, 50/60Hz.
- 2.5 Before adjustment, execute Heat-Run for 30 minutes at RF no signal

## 3. Adjustment items

### 3.1 PCB assembly adjustment items

- Channel memory
- Download the channel data from BOM to EEPROM by using LGIDS.
- Option adjustment following BOM
- Tool Option1
- Tool Option2
- Area Option

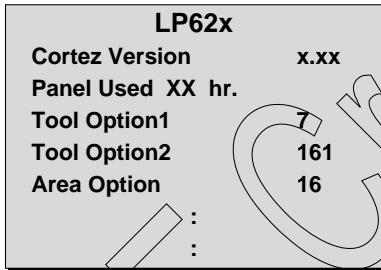

(Fig. 1)

- 1) Push the ADJ key in the Adjust Remocon.
  - 2) Input the Option Number that was specified in the BOM, into the Shipping area.
  - 3) Select "Tool Option1/ Tool Option2/ Area Option" by using ▲/▼(CH+/-) key, and press the number key(0~9) consecutively
- ex) If the value of Tool Option1 is 7, input the data using number key "7" (Fig. 1)

### 3.2 SET assembly adjustment items

- Auto AV(ZH-AV3, TH-AV1) Color Balance
- Aging (by Power on key)
- Adjustment of White Balance
- Auto Component Color Balance adjustment
  - Standard equipment : MSPG925FA
- Auto RGB Color Balance adjustment
  - Standard equipment : MSPG925FA

## 4. EDID

### Caution

- \* Use the proper signal cable for EDID Download
  - Analog EDID : Pin3 exists
  - Digital EDID : Pin3 exists
- => Caution: - Never connect HDMI & DVI-D & DVI-A Cable at the same time.
- Use the proper cables below for EDID Writing

### 4.1 EDID Data

#### 4.1.1. ANALOG(256 Bytes)

##### • BLOCK1 (128BYTE)

	00	01	02	03	04	05	06	07	08	09	0A	0B	0C	0D	0E	0F
00	00	FF	FF	FF	FF	FF	FF	00	1E	6D	a	b				
10	c	01	03	01	46	27	78	EA	D9	B0	A3	57	49	9C	25	
20	11	49	4B	A5	6E	80	31	40	01	01	01	01	45	40	01	01
30	61	40	01	01	01	01	1B	21	50	A0	51	00	1E	30	48	88
40	35	00	BC	88	21	00	00	1C	4E	1F	00	80	51	00	1E	30
50	40	80	37	00	BC	88	21	00	00	18	00	00	00	FD	00	38
60	4B	1F	3D	09	00	0A	20	20	20	20	20	d				
70	d														00	99

#### 4.1.2. HDMI(256 Bytes)

##### • BLOCK1 (128BYTE)

	00	01	02	03	04	05	06	07	08	09	0A	0B	0C	0D	0E	0F		
00	00	FF	FF	FF	FF	FF	FF	00	1E	6D	a	b						
10	e	01	03	80	46	27	78	EA	D9	B0	A3	57	49	9C	25			
20	11	49	4B	A5	6E	80	31	40	01	01	01	01	45	40	01	01		
30	61	40	01	01	01	01	1B	21	50	A0	51	00	1E	30	48	88		
40	35	00	BC	88	21	00	00	1C	4E	1F	00	80	51	00	1E	30		
50	40	80	37	00	BC	88	21	00	00	18	d							
60	d														00	00	00	FD
70	00	38	4B	1F	3D	09	00	0A	20	20	20	20	20	20	01	14		

##### BLOCK2 (128BYTE)

	00	01	02	03	04	05	06	07	08	09	0A	0B	0C	0D	0E	0F
00	02	03	24	F1	49	85	04	02	01	03	11	12	13	14	23	09
10	07	07	23	09	07	07	23	09	07	07	83	01	00	00	65	03
20	0C	00	10	00	01	1D	00	80	51	D0	1C	20	40	80	35	00
30	BC	88	21	00	00	1E	8C	0A	D0	8A	20	E0	2D	10	10	3E
40	96	00	13	8E	21	00	00	18	2A	12	00	10	41	43	17	20
50	28	60	35	00	00	00	32	00	00	1C	01	1D	80	18	71	1C
60	16	20	58	2C	25	00	C4	8E	21	00	00	9E	00	00	00	00
70	00	00	00	00	00	00	00	00	00	00	00	00	00	00	00	6B

=> Detail EDID Options are below (a, b, c, d, e)

#### a. Product ID

Model Name	Product ID	Product ID		
		Dec	Hex	EDID table
37LC2R	30059(A)	30059	756B	6B75
	30060(D)	30060	756C	6C75
42LC2R	40023(A)	40023	9C57	579C
	40024(D)	40024	9C58	589C

b. Serial No : Controlled on production line

c. Month, Year : Controlled on production line:

ex) Montly : '03' => '03'

Year : '2005' => '0F'

d. Model Name/Monitor Name:

Model Name																				
37LC2R-TH	00	00	00	FC	00	33	37	4C	43	32	52	2D	54	48	0A	20	20	20		
42LC2R-TH	00	00	00	FC	00	34	32	4C	43	32	52	2D	54	48	0A	20	20	20		

e. Checksum: Changeable by total EDID data

Master pattern generator like MSPG-925)

- If Minimum Black Level and/or Maximum White Level is not correct, Do select 100% Color Bar Pattern.

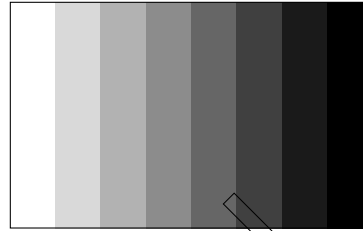

(Fig. 2)

## 5. ADC Calibration

### 5.1 Adjustment of RF/AV/S-VIDEO

\* Required Equipments

- Remote controller for adjustment
- 802F Pattern Generator, Master (MSPG-925FA), etc.
- MSPG-925FA Pattern Generator  
(Which has Video Signal: 100% Color Bar Pattern shown in Fig. 1)

⇒ Model : 202 / Pattern: 33 (PAL : ZH, TH)

Model : 201 / Pattern : 33 (NTSC : MH)

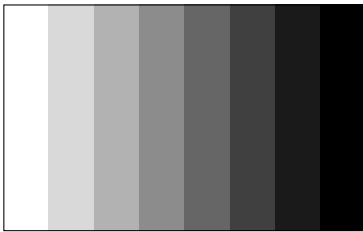

(Fig. 1)

#### 5.2.1 Method of Auto Component Color Balance

- 1) Input the Component 720p 100% Color Bar(MSPG-925FA model:217, pattern:33) signal into Component.  
(ZH : component , TH/MH : component 1 or 2)
- 2) Set the PSM to Standard mode in the Picture menu.
- 3) Press the INSTART key on R/C for adjustment.
- 4) Press the ►(Vol. +) key to operate the set , then it becomes automatically.
- 5) Auto-RGB OK means the adjustment is completed.

### 5.3 Adjustment of RGB

\* Required Equipments

- Remote controller for adjustment
- 802F Pattern Generator, Master (MSPG-925FA), etc.
- MSPG-925FA Pattern Generator

(Which has XGA [1024x768] 60Hz PC Format output signal : 100% Color Bar Pattern shown in Fig. 3 )

- It is very important to use correct adjustment pattern like Fig. 10.

- Within the pattern, color sequence should be aligned : W-Y-C-G-M-R-BLUE-BLACK

(If color sequence is reversed (Black ->...-> White), reverse the pattern with REV key, when using Master pattern generator like MSPG-925)

- If Minimum Black Level and/or Maximum White Level is not correct, Do select 100% Color Bar Pattern.

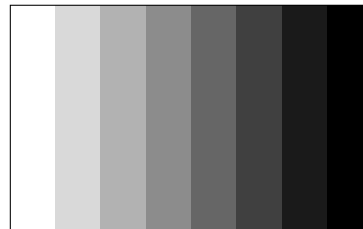

(Fig. 3)

#### 5.1.1 Method of Auto RF/AV/S-VIDEO Color Balance.

- 1) Press the FRONT-AV KEY on R/C for converting input mode.
- 2) Input the Video Signal: 100% Color Bar signal into AV3(ZH), AV1(TH), VIDEO1(MH)
- 3) Set the PSM to Standard mode in the Picture menu.
- 4) Press INSTART key on R/C for adjustment.
- 5) Press the ►(Vol.+) key to operate the set, then it becomes automatically
- 6) Auto-RGB OK means the adjustment is completed

#### 5.1.2 Requirement

- This AV color balance adjustment should be performed before White Balance Adjustment.
- After color balance adjustment, You must push "power on" key. ("Power on" key is "Access Heat\_run mode")

### 5.2 Adjustment of Component.

\* Required Equipments

- Remote controller for adjustment
- 802F Pattern Generator, Master (MSPG-925FA), etc.
- MSPG-925FA Pattern Generator  
(Which has 720p YPbPr signal : 100% Color Bar Pattern shown in Fig. 2 )

⇒ Model: 217 / Pattern: 33

- It is very important to use correct adjustment pattern like Fig. 2.  
- Within the pattern, color sequence should be aligned : W-Y-C-G-M-R-BLUE-BLACK  
(If color sequence is reversed (Black -> ... -> White), reverse the pattern with REV key, when using

#### 5.3.1 Method of Auto RGB Color Balance

- 1) Input the PC 1024x768@60Hz 1/2 Black&White Pattern (MSPG-925FA model:3, pattern:33) into RGB.
- 2) Set the PSM to Standard mode in Picture menu.
- 3) Press the INSTART key on R/C for adjustment.
- 4) Press the ►(Vol. +) key operate To set , then it becomes automatically.
- 5) Auto-RGB OK means adjustment is completed.

=> **Caution : Before White-balance, the AV ADC should be done. (ZH:AV3, TH:AV1, MH:VIDEO1)**

=> **After Aging, When the procedure is changed White balance adjustment, it will be canceled Heat\_run mode auto.**

(Notice : Before White-balance, change input mode Move to AV3(ZH) or AV1(TH) or VIDEO1(MH) by using the FRONT-AV KEY on Remote controller.)

## 6. White Balance

White balance		ZH(AV3), TH(AV1)	MH(VIDEO1)
MSPG925FA	216 Level (85IRE)	Model : 202	Model : 201
	Full screen pattern	• Pal Video	• NTSC Video

=> **Caution :** - System control RS-232 Host should be "PC" for adjustment.

- AV ADC(ZH: AV3, TH : AV1, MH: VIDEO1) should be done before White-balance.

### \* Test Equipment

Color Analyzer (CA-110)

PC(For communication through RS-232C)=>UART

Baud rate : 115200

Pattern Generator (MSPG-925FA etc.)

\*Target Value [ PSM: Standard(ZH/TH), CSM: Normal]

- Normal(9300K±1000K) x:283±0.015, y: 298±0.015

-Luminance(Y) AV/COMP: 250 Cd/m<sup>2</sup> (Typ: 300 Cd/m<sup>2</sup>)

PC : 300 Cd/m<sup>2</sup> (Typ: 350 Cd/m<sup>2</sup>)

=> Reference Value(Automatically fixed)

- Cool(11000K±1000K)

- Warm(7200K±1000K)

## 6.1 Manual white Balance (AV)

- 1) Execute CA-110 Zero Calibration.
- 2) Execute the SET Heat Run for 30minutes
- 3) As below Fig. 4, Supply 216Level (85 IRE) full screen pattern to Video input.  
37LC2R-ZH,42LC2R-ZH : AV3/AV4 (Input 50Hz),  
32LB1R-TH : AV1/AV2 (Input 50Hz)
- 4) Press the FRONT-AV KEY on R/C for converting input mode.
- 5) Set the PSM to Standard mode in Picture menu.
- 6) Enter the White Balance adjustment mode by pressing the INSTART key twice(White Balance) on R/C.
- 7) Stick sensor to center of the screen and select each items (Red/Green/Blue Gain and Offset) using ▲▼(CH+/-) key on R/C.
- 8)Adjust Only High Light with R Gain/B Gain using ◀▶ (VOL +/-) key on R/C.
- 9) Adjust it until color coordination becomes as below.  
X-axis : 0.283±0.003  
Y-axis : 0.298±0.003  
(R/G/B gain and R/G/B offset Default values are different in according to using module )
- 10) Adjust High light with R/B Gain.

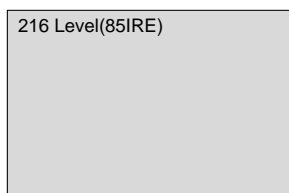

(Fig.4)

## 6.2 Auto white Balance (AV)

### 1) LPL Module

	Command1	Command2	Set ID	Data	
				Min	Max
Input Select	XB	B	00	00h	90h
R-Gain	J	A	00	00h	E0h
G-Gain	J	B	00	00h	E0h
B-Gain	J	C	00	00h	E0h
R-Offset	J	D	00	00h	90h
G-Offset	J	E	00	00h	90h
B-Offset	J	F	00	00h	90h

### 2) AUO Module

	Command1	Command2	Set ID	Data	
				Min	Max
Input Select	XB	B	00	00h	90h
R-Gain	J	A	00	00h	E0h
G-Gain	J	B	00	00h	E0h
B-Gain	J	C	00	00h	E0h
R-Offset	J	D	00	00h	90h
G-Offset	J	E	00	00h	90h
B-Offset	J	F	00	00h	90h

## 7. Shipping Conditions

No	Item		Condition	Remark	
1	Power		Off		
2	Volume Level		30		
3	Main Picture Input		TV		
4	Main Last Channel		Pr 01		
5	Mute		Off		
6	ARC		16 : 9		
7	Station	Auto Programme			
		Manual Programme			
		Programme Edit			
		Favorite Programme	None		
8	Picture	PSM	Dynamic		
		Dynamic	Contrast	100	
			Brightness	50	
			Colour	50	
			Sharpness	50	
		CSM	Normal		
		XD	Auto		
		Advanced			
Reset					
9	Sound	SSM	Flat		
			Off		
		AVL	Off		
		Balance	0		
			50		
		Speaker	On		
10	Time	Clock	--:--	User control	
		Off time	Off		
		On time	Off		
		Auto sleep	Off		
11	Special	Language	English	Area management	
		Child Lock	Off		
		Set ID	1		
		XD Demo	To start		
12	Screen	Auto config.	Variable by each mode		
		Manual config.			
		XGA/VGA mode			
		ARC			
		PFP Transparency			
Reset					

# SVC REMOCON

NO	KEY	FUNTION	REAMARK
1	POWER	To turn the TV on or off	
2	POWER ON	To turn the TV on automatically if the power is supplied to the TV. (Use the POWER key to deactivate): It should be deactivated when delivered.	
3	MUTE	To activate the mute function.	
4	P-CHECK	To check TV screen image easily.	Shortcut keys
5	S-CHECK	To check TV screen sound easily	Shortcut keys
6	ARC	To select size of the main screen (Normal, Spectacle, Wide or Zoom)	Shortcut keys
7	CAPTION	Switch to closed caption broadcasting	
8	TXT	To toggle on/off the teletext mode	
9	TV/AV	To select an external input for the TV screen	
10	TURBO SOUND	To start turbo sound	
11	TURBO PICTURE	To start turbo picture	
12	IN-START	To enter adjustment mode when manufacturing the TV sets. To adjust the screen voltage (automatic): In-start → mute → Adjust → AV(Enter into W/B adjustment mode) W/B adjustment (automatic): After adjusting the screen → W/B adjustment → Exit two times (Adjustment completed)	Use the AV key to enter the screen W/B adjustment mode.
13	ADJ	To enter into the adjustment mode. To adjust horizontal line and sub-brightness.	
14	MPX	To select the multiple sound mode (Mono, Stereo or Foreign language)	
15	EXIT	To release the adjustment mode	
16	APC(PSM)	To easily adjust the screen according to surrounding brightness	
17	ASC(SSM)	To easily adjust sound according to the program type	
18	MULTIMEDIA	To check component input	Shortcut keys
19	FRONT-AV	To check the front AV	Shortcut keys
20	CH±	To move channel up/down or to select a function displayed on the screen.	
21	VOL±	To adjust the volume or accurately control a specific function.	
22	ENTER	To set a specific function or complete setting.	
23	PIP CH-(OP1)	To move the channel down in the PIP screen To use as a red key in the teletext mode	
24	PIP CH+(OP2)	To move the channel in the PIP screen To use as a green key in the teletext mode	
25	PIP SWAP(OP3)	To switch between the main and sub screens. To use as a yellow key in the teletext mode	
26	PIP INPUT(OP4)	To select the input status in the PIP screen To use as a blue key in the teletext mode	
27	EYE	To set a function that will automatically adjust screen status to match the surrounding brightness so natural color can be displayed.	
28	MENU	To select the functions such as video, voice, function or channel.	
29	IN-STOP	To set the delivery condition status after manufacturing the TV set.	
30	STILL	To halt the main screen in the normal mode, or the sub screen at the PIP screen. Used as a hold key in the teletext mode (Page updating is stopped.)	
31	TIME	Displays the teletext time in the normal mode Enables to select the sub code in the teletext mode	
32	SIZE	Used as the size key in the PIP screen in the normal mode Used as the size key in the teletext mode	
33	MULTI PIP	Used as the index key in the teletext mode (Top index will be displayed if it is the top text.)	
34	POSITION	To select the position of the PIP screen in the normal mode Used as the update key in the teletext mode (Text will be displayed if the current page is updated.)	
35	MODE	Used as Mode in the teletext mode	
36	PIP	To select the simultaneous screen	
37	TILT	To adjust screen tilt	Shortcut keys
38	0~9	To manually select the channel.	

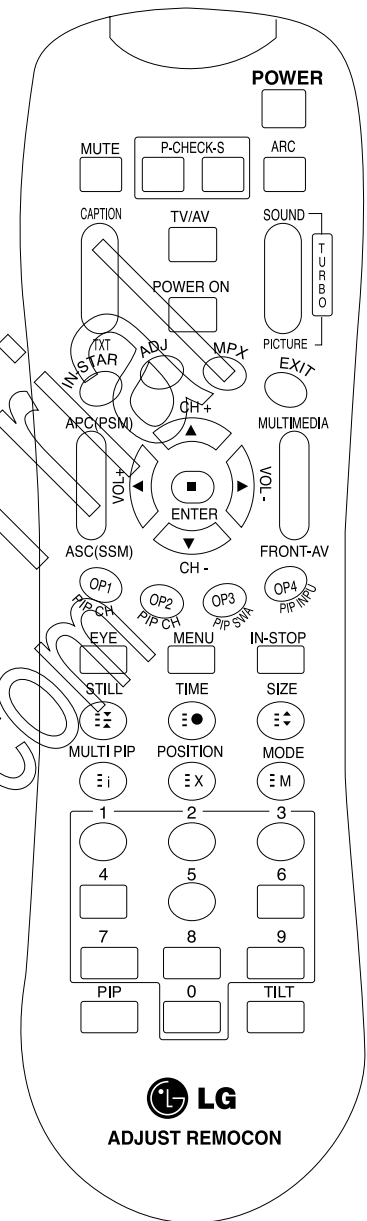

# TROUBLESHOOTING

## 1. No power

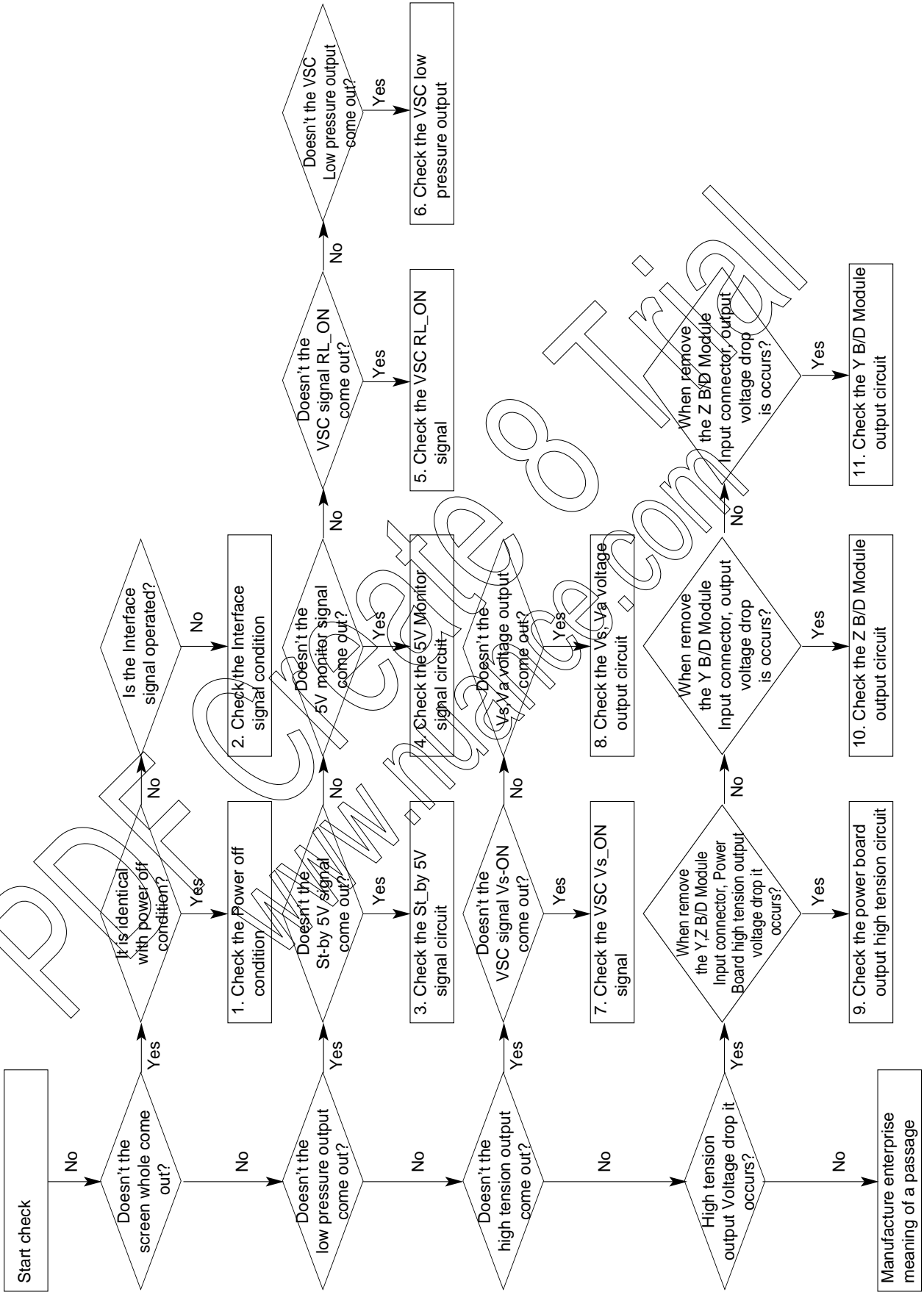



## 2. VSC Board

### 2-1. No Power

#### (1) Symptom

- 1) Minute discharge doesn't occur at module.
- 2) Front LED doesn't come into action

#### (2). Check follow

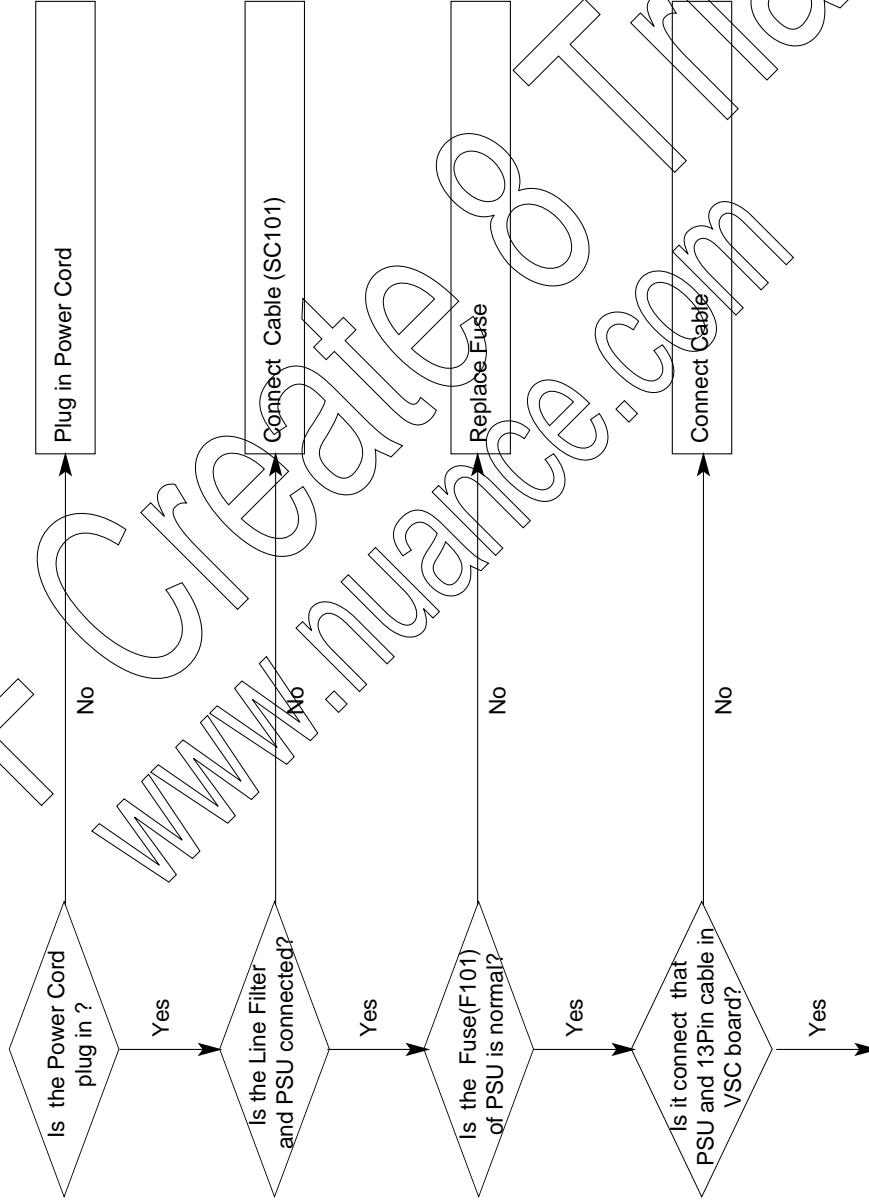

After remove the cable connect to Power Board(except the CN101 connection cable), authorizes the AC voltage marking on manual.  
When ST-BY 5V does not operate, replace Power Board.

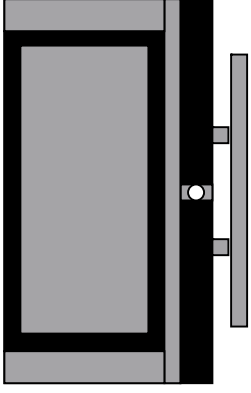

## 2-2. No Raster - LCD

### (1) Symptom

- 1) Does't minute discharge at module.
- 2) It maintains the condition where the front LED is normal.

### (2) Check follow

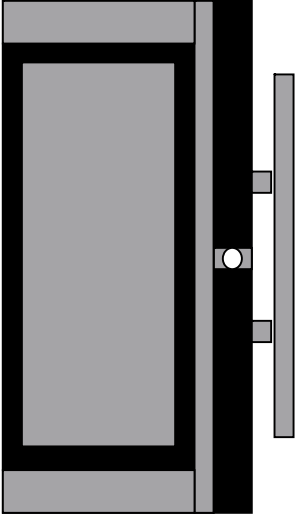
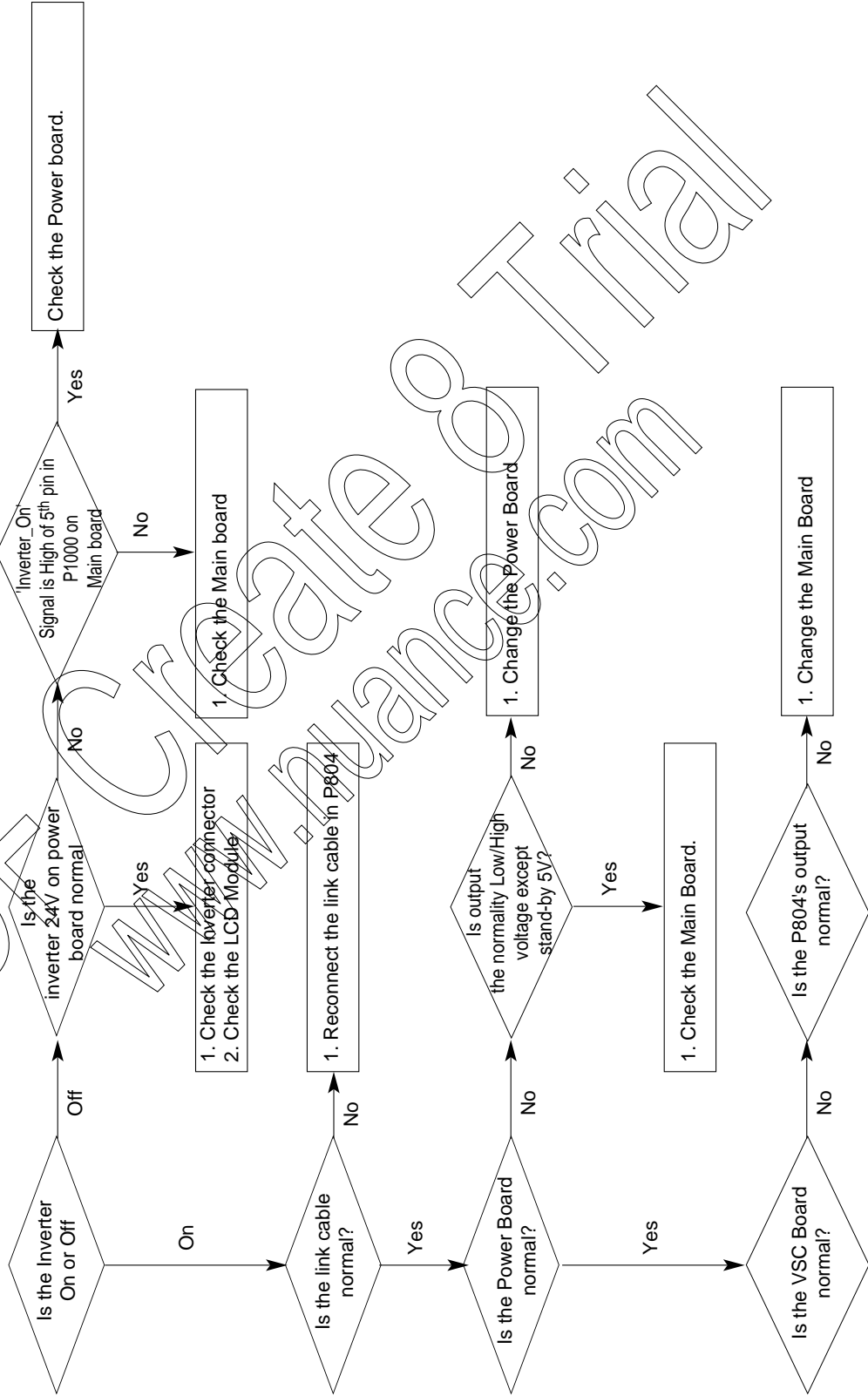

**2-3. In case of occur strange screen into specific mode**

2-3-1. In case of doesn't display the OSD

(1) Symptom

- 1) LED is White
- 2) The minute discharge work continuously

(2) Check follow

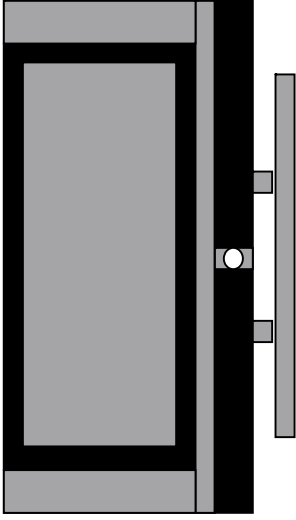
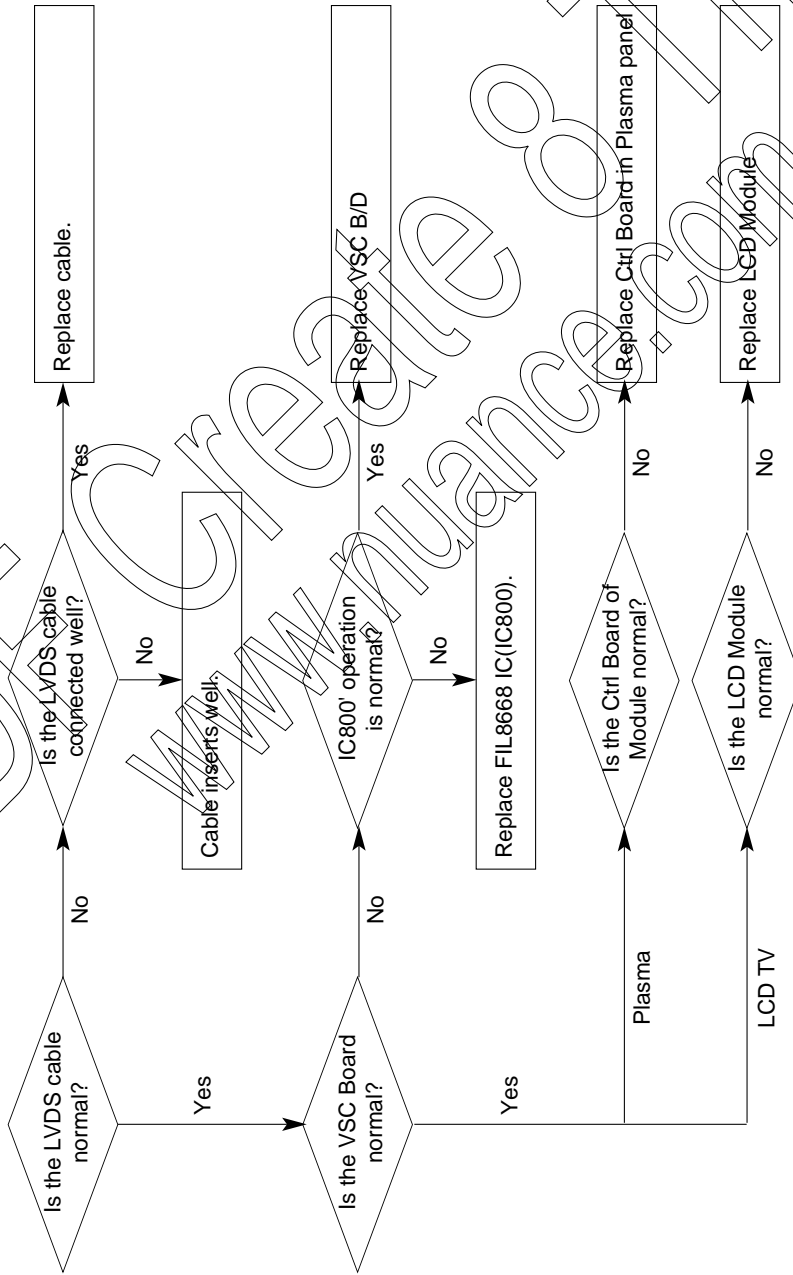

**2-3-2. In the case of doesn't work normally at specific input mode**

**(1) Symptom**

1) The screen doesn't work normally at specific input mode (RF, AV, Component, RGB, HDMI)

**(2) Check follow**

- 1) Check the all input model if all input display normally.
- 2) Check the PIP and Double Window if it display normally. (Re-Check it Swap)

**(3) In case of unusual situation from RF mode**

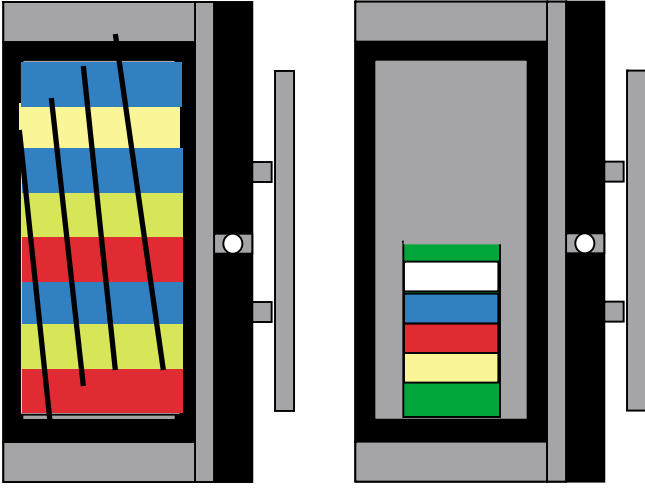
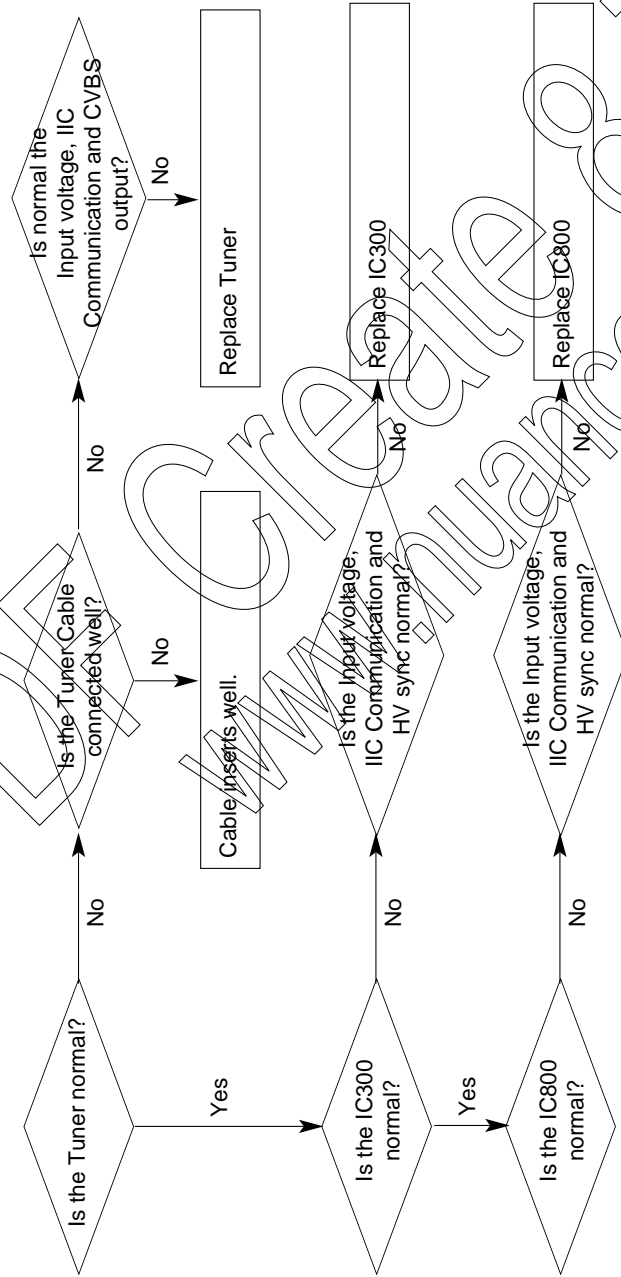

**(4) When set doesn't display normally at RF , AV mode**

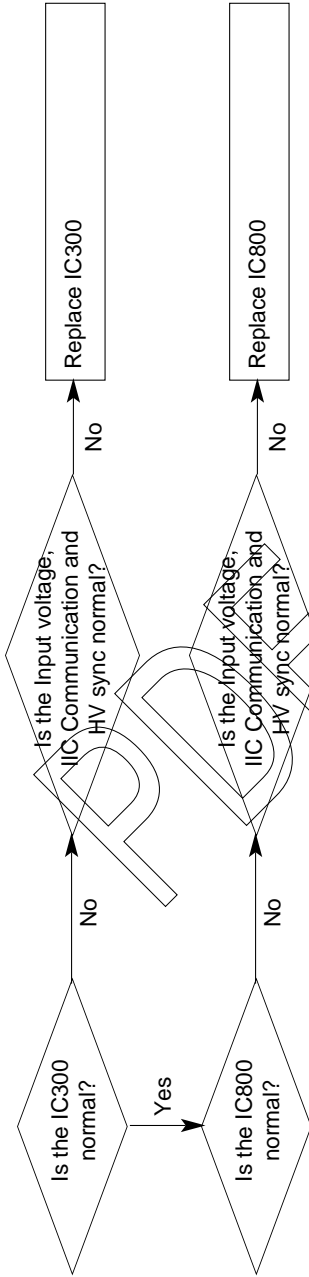

**(5) When set doesn't display normally at Component, RGB mode**



**(6) In the case of becomes unusual display from HDMI mode**

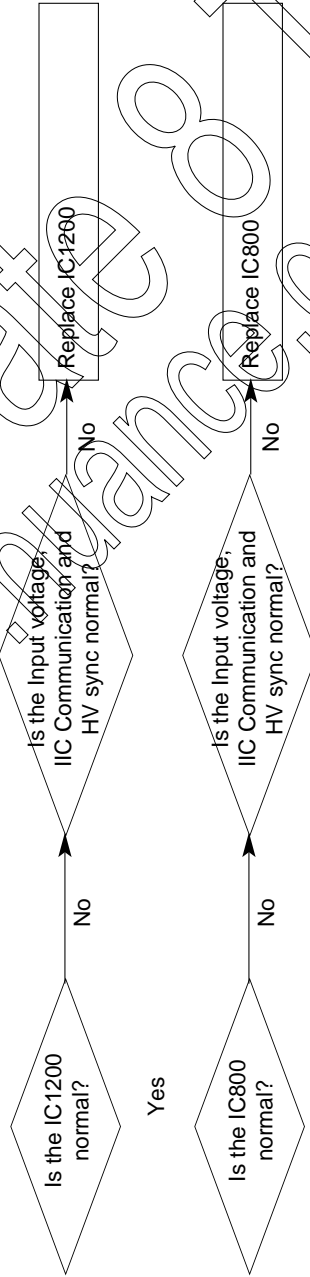

**2-4. In case of no sound**

**(1) Symptom**

- 1) LED is White
- 2) Screen existent, but Sound isn't

**(2) Check follow**

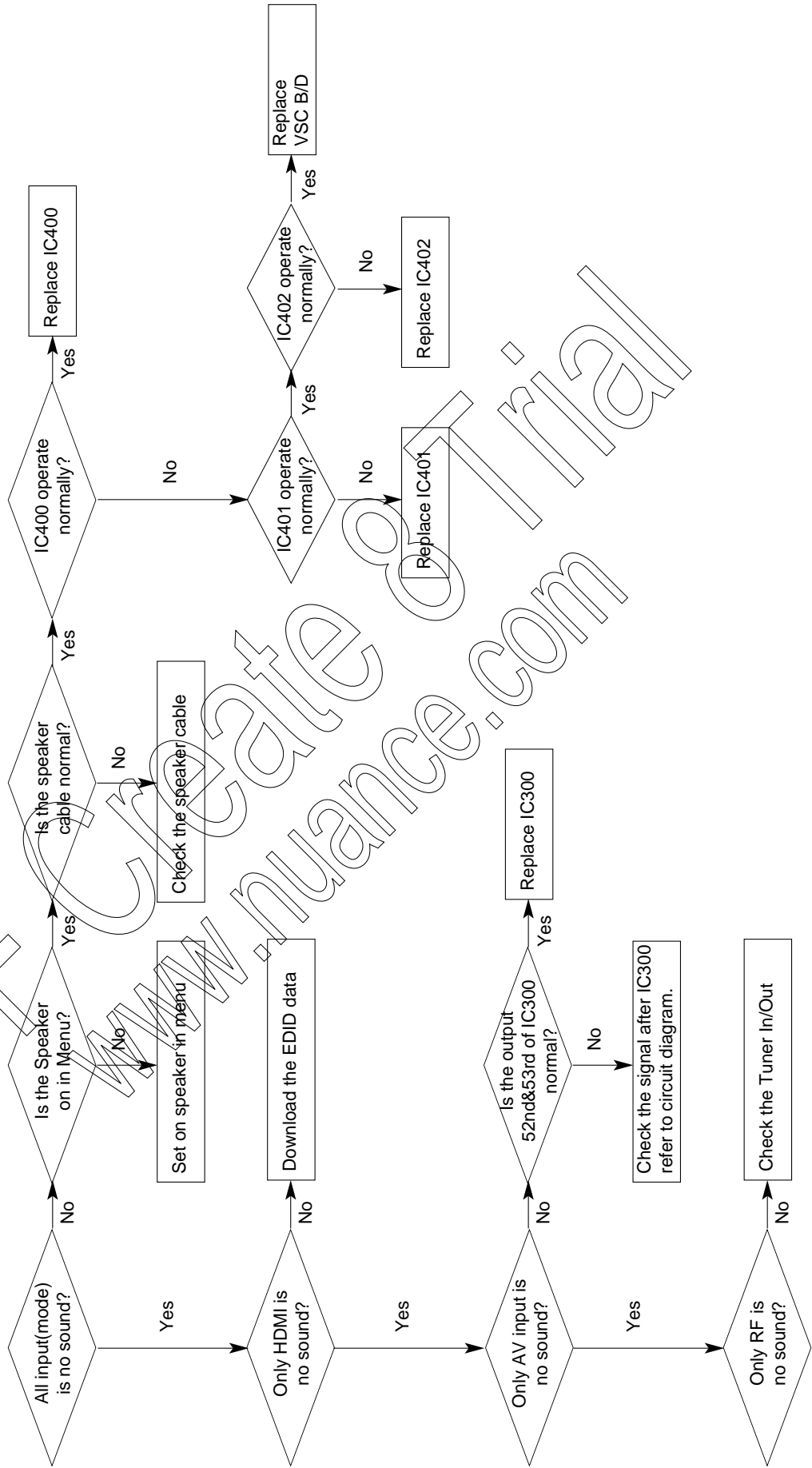

# BLOCK DIAGRAM

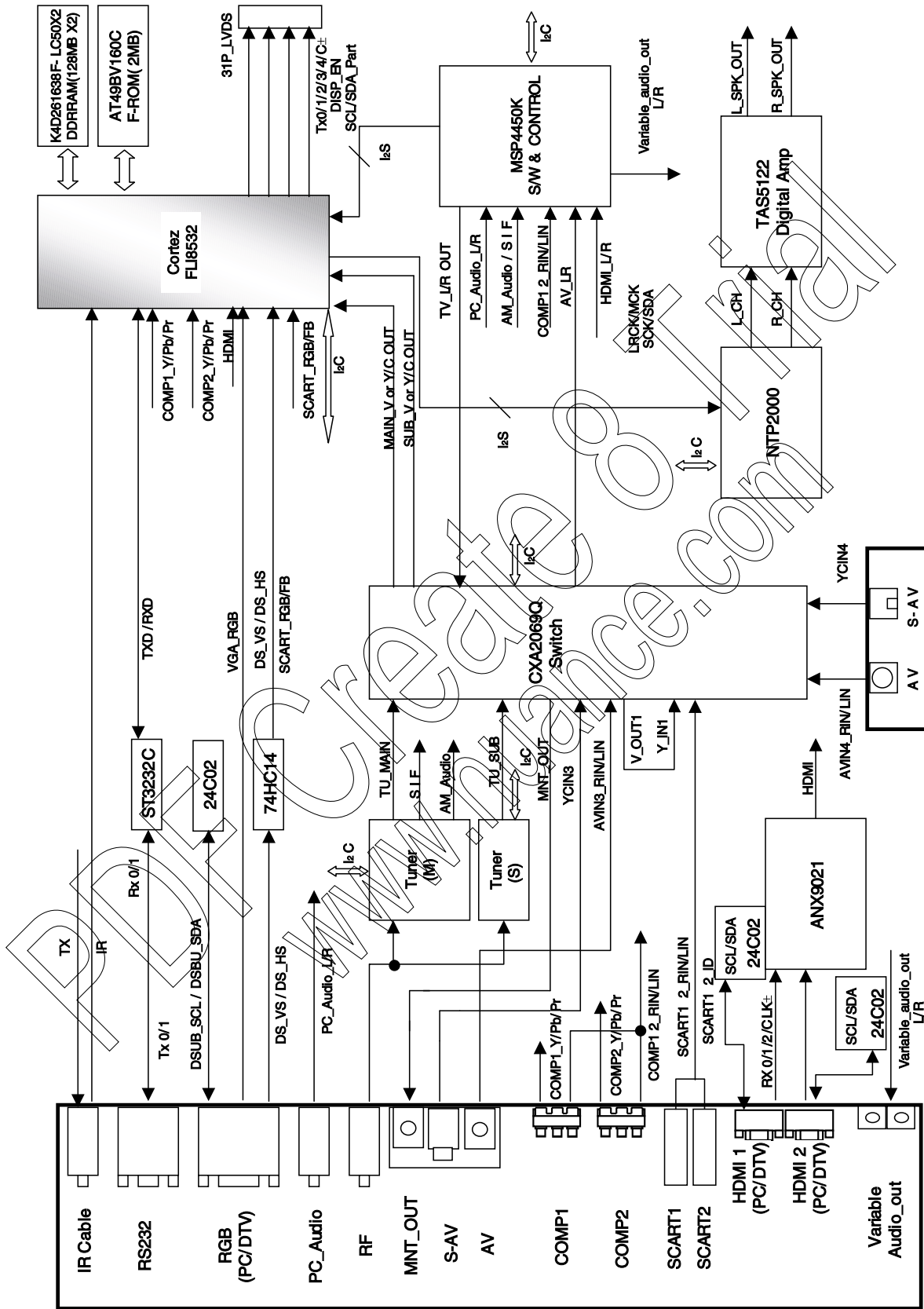

**EXPLODED VIEW (37LC2R)**

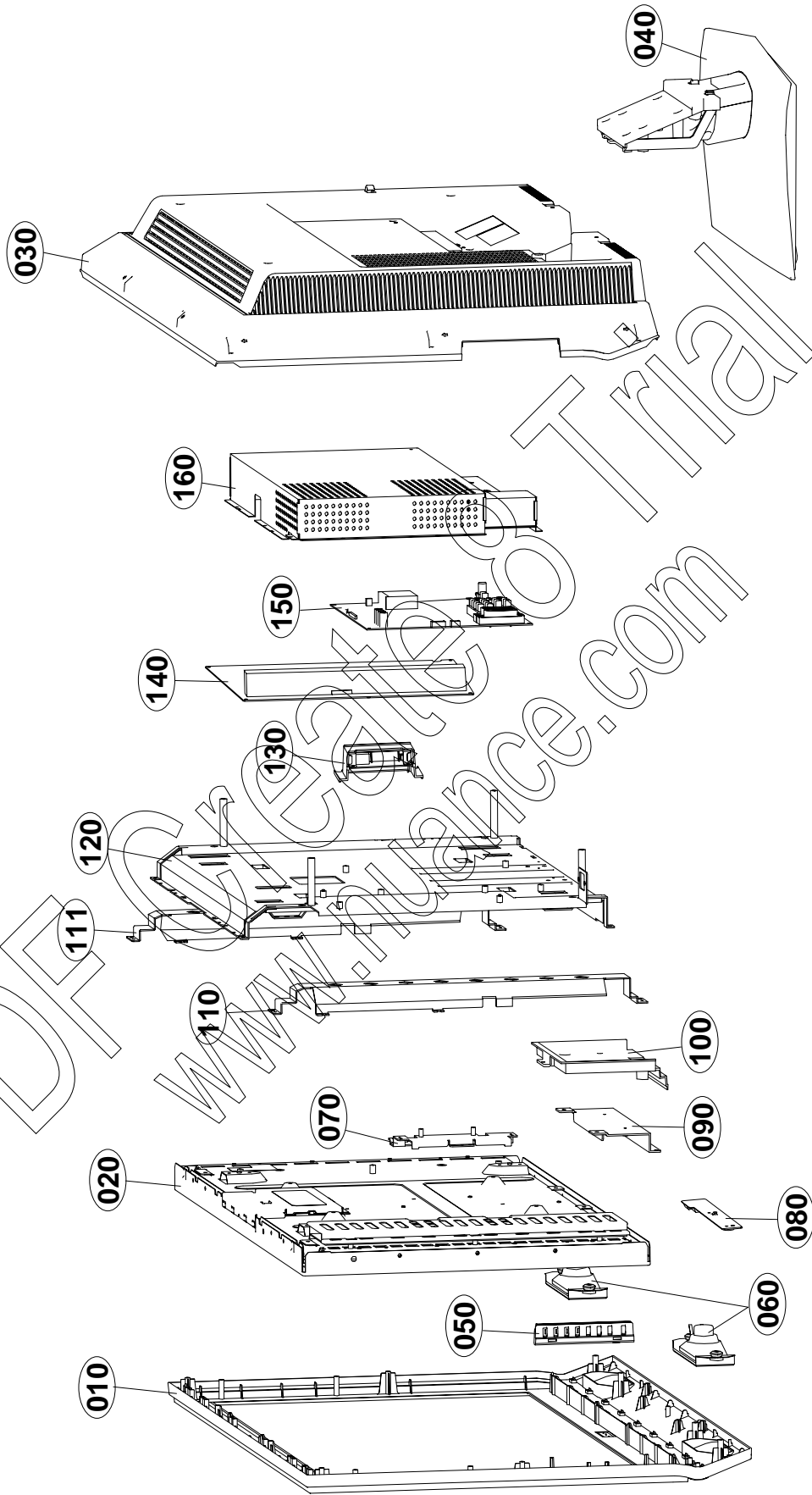



## EXPLODED VIEW PARTS LIST(37LC2R)

No.	PART NO.	DESCRIPTION
010	▲ 30919E0046J	Cover Assembly, 37LC2R-ZH BRAND 30909E0027 FOR EU(C/SKD)
	30919E0046H	Cover Assembly, 37LC2R-ZH BRAND 30909E0027 FOR EU
020	▲ 6304FAU023A	LCD,Panel-TFT, T370XW01-V1 37INCH 1366X768 500CD COLOR 72% T370XW01-V1 500NITS 8MS 20LAMPS
030	▲ 3809900164F	Cover Assembly, 37LC2R-ZH NON H3-H(C/SKD)
	3809900164E	Cover Assembly, 37LC2R-ZH NON H3-H-atsula
040	▲ 3043900032B	Base Assembly, 37LC2D-UD 35509K0214 FOR WORLDWIDE, BODY ASSY(C/SKD)
	3043900032E	Base Assembly, 37LC2D-EC 35509K0214 FOR NON USA, BASE ASSY(C/SKD)
	3043900032C	Base Assembly, 37LC2D-ND 35509K0214 FOR KOREA
050	68719ST997B	PCB Assembly,Sub, SUB T.T LP62A 37LC2R-ZH ALEULFX LOCAL KEY
060	6400WMCX03A	Speaker,Woofer, G1560102 ND35 15W 8QHM 82DB 100HZ 193X57mM LUG
070	4814V00520B	Plate, PRESS SPTTE T0.5 PLATE RT-42PX40 SHIELD TUNER BOTTOM AP03NC SUS PRESS
080	68719ST105A	PCB Assembly,Sub, SUB T.T LP62A 37LC2R-ZH ALEULFX PREAMP + LED LC
090	49509K0222A	Plate, PRESS SBHG T2.0 SUPPORT STAND 37LC2
100	35509K0217A	Cover, MOLD HIPS 37LC2 STAND MID INNER
110	49509K0341C	Plate, PRESS EGI 1.6 SUPPORTER SPC AUO SIDE FRAME (RIGHT, C/SKD)
	49509K0340D	Plate, PRESS EGI 1.6 SUPPORTER SPC 37LC2R(AUO)
	49509K0341E	Plate, PRESS EGI 1.6 SUPPORTER SPC AUO-SKD, For Thailand, Vietnam
111	49509K0340C	Plate, PRESS EGI 1.6 SUPPORTER SPC SIDE FRAME(AUO, LEFT, C/SKD)
	49509K0341D	Plate, PRESS EGI 1.6 SUPPORTER SPC 37LC2R(AUO),LEFT
	49509K0340E	Plate, PRESS EGI 1.6 SUPPORTER SPC SIDE FRAME(AUO, LEFT, C/SKD)-For Thailand, Vietnam
120	4950TKA361M	Plate, FRAME, MAIN 37LC2R(C/SKD)
	4950TKA361L	Plate, FRAME, MAIN 37LC2R-atsula
130	68719STA69A	PCB Assembly,Sub, SUB T.T LP62C 37LC2R-TH AURDLFX SIDE A/V 37LC TH
140	▲ 6709900016D	SMPS,AC/DC, LGLP2637HEP 90.0VTO264.0V 215W 47TO63HZ UL/CSA/SEMKO YY / AT / HE
150	▲ 33139L3049A	Main Total Assembly, 37LC2R-TH BRAND LP62A-C/SKD
	33139L3022B	Main Total Assembly, 32LC2R-TH AUO BRAND LP62A
160	4950TKA362N	Plate, SHIELD, MAIN PLUS ANALOG AV(37LC2R-TH),C/SKD
	4950TKA362M	Plate, SHIELD, MAIN PLUS ANALOG AV(37LC2R-TH)

EXPLODED VIEW(42LC2R)

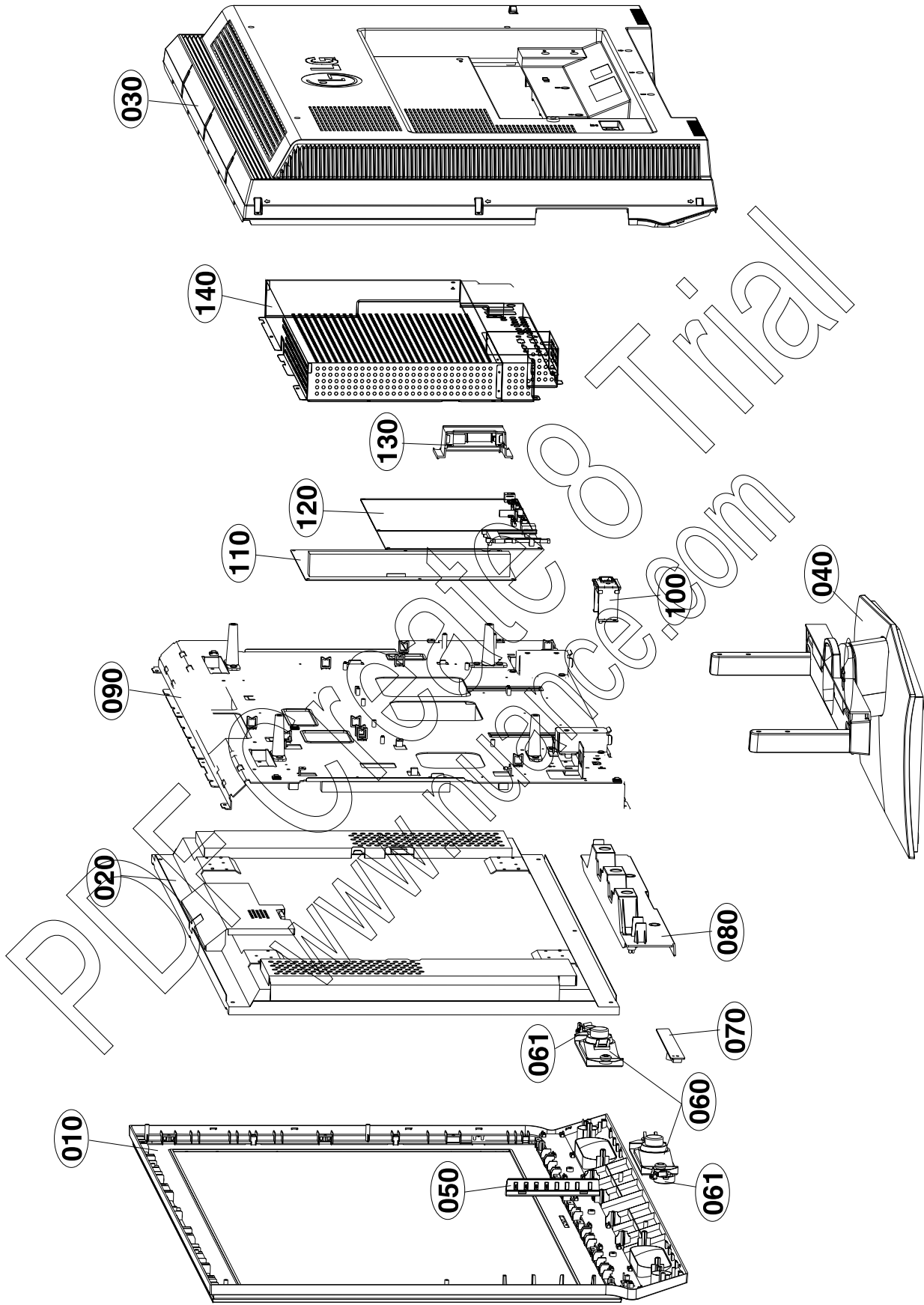

## EXPLODED VIEW PARTS LIST(42LC2R)

No.	PART NO.	DESCRIPTION
010	30919E0047H	Cover Assembly, 42LC2R BRAND 30909E0028 ZH C/SKD
020	6304FLP363A	LCD,Panel-TFT, LC420W02-SLA1 42INCH 1365X768 500CD COLOR 72% -
	or 6304FLP353A	LCD,Panel-TFT, LC420W02-B6K2 42INCH 1365X768 500CD COLOR 72% -
030	3809900165L	Cover Assembly, 42LC2R HURRICANE 42" SPRAY
040	3043900034C	Base Assembly, 42LC2 42LC2 FOR USA C/SKD
050	68719ST997B	PCB Assembly,Sub, SUB T.T LP62A 37LC2R-ZH ALEULFX LOCAL KEY
	68719ST997C	PCB Assembly, SUB T.T LP62A 37LC2R-ZH ALEULFX LOCAL KEY <b>NT CKD</b>
060	6400WMCX03A	Speaker,Woofer, G1560102 ND35 15W 80HM 82DB 100HZ 193X57mm LUG
061	6400DTTX02A	Speaker,Tweeter, EN15D-6629 TOPTONE TWEETER(DOME) 80HM 15/20W 78DB OTHERS LC2 MODEL
070	68719ST105A	PCB Assembly,Sub, SUB T.T LP62A 37LC2R-ZH ALEULFX PREAMP + LED LC
	68719ST105C	PCB Assembly, SUB T.T LP62A 37LC2R-ZH ALEULFX PREAMP + LED LC <b>NT CKD</b>
080	35519K0030D	Cover Assembly, 42LC2 STAND 35509K0220B SUPPORT C/SKD
090	49519S0036F	Plate Assembly, FRAME MAIN 42LC2R-ZH C/SKD
100	31419SNJ81A	Chassis Assembly, SUB LA51D AC INLET ASSY
110	6709900017B	SMPS,AC/DC, YP4201 90.0V TO 264.0V 280W 47TO63HZ UL/GSA/TUV/SEMKO 42" LCD
120	33139L3050A	Main Total Assembly, 42LC2R-TH BRAND LP62A
	33139L3050C	Main Total Assembly, 42LC2R-TH BRAND LP62A <b>NT CKD</b>
130	68719STA68A	PCB Assembly,Sub, SUB T.T LP62C 42LC2R-TH AURDLFX SIDE A/V FOR 42LC TH
	68719STA68C	PCB Assembly, SUB T.T LP62C 42LC2R-TH AURDLFX SIDE A/V FOR 42LC TH <b>NT CKD</b>
140	49509K0173H	Plate SHIELD MAIN ANALOG 42LC2R-TH C/SKD

# REPLACEMENT PARTS LIST

For Capacitor & Resistors, the characters at 2nd and 3rd digit in the P/No. means as follows;

CC, CX, CK, CN, CH : Ceramic  
CQ : Polyester  
CE : Electrolytic  
CF : Fixed Film

RD : Carbon Film  
RS : Metal Oxide Film  
RN : Metal Film  
RH : CHIP, Metal Glazed(Chip)  
RR : Drawing

DATE: 2006. 04. 05.			
*S	*AL	LOC. NO.	PART NO. DESCRIPTION / SPECIFICATION
<b>MAIN BOARD</b>			
<b>CAPACITOR</b>			
		C1001	OCE477WF6DC MVK10TP16VC470M 470uF 20% 1
		C1005	OCE477WF6DC MVK10TP16VC470M 470uF 20% 1
		C1007	OCE476WF6DC MVK6.3TP16VC47M 47uF 20% 16
		C1009	OCE477WF6DC MVK10TP16VC470M 470uF 20% 1
		C1012	OCE476WF6DC MVK6.3TP16VC47M 47uF 20% 16
		C1014	OCE477WF6DC MVK10TP16VC470M 470uF 20% 1
		C1016	OCE107WF6DC MVK6.3TP16VC100M 100uF 20%
		C1019	OCE477WF6DC MVK10TP16VC470M 470uF 20% 1
		C1020	OCE107WF6DC MVK6.3TP16VC100M 100uF 20%
		C1022	OCE107WF6DC MVK6.3TP16VC100M 100uF 20%
		C1023	OCE477WF6DC MVK10TP16VC470M 470uF 20% 1
		C1048	OCE107WF6DC MVK6.3TP16VC100M 100uF 20%
		C1049	OCE107WF6DC MVK6.3TP16VC100M 100uF 20%
		C1050	OCE107WF6DC MVK6.3TP16VC100M 100uF 20%
		C1051	OCE107WF6DC MVK6.3TP16VC100M 100uF 20%
		C1053	OCE476WF6DC MVK6.3TP16VC47M 47uF 20% 16
		C1054	OCE476WF6DC MVK6.3TP16VC47M 47uF 20% 16
		C1062	OCE476WF6DC MVK6.3TP16VC47M 47uF 20% 16
		C1063	OCE476WF6DC MVK6.3TP16VC47M 47uF 20% 16
		C1064	OCE476WF6DC MVK6.3TP16VC47M 47uF 20% 16
		C1065	OCE476WF6DC MVK6.3TP16VC47M 47uF 20% 16
		C1067	OCE477WF6DC MVK10TP16VC470M 470uF 20% 1
		C1069	OCE477WF6DC MVK10TP16VC470M 470uF 20% 1
		C1070	OCE107WF6DC MVK6.3TP16VC100M 100uF 20%
		C1072	OCE476WF6DC MVK6.3TP16VC47M 47uF 20% 16
		C1084	OCE476WF6DC MVK6.3TP16VC47M 47uF 20% 16
		C1085	OCE476WF6DC MVK6.3TP16VC47M 47uF 20% 16
		C1086	OCE476WF6DC MVK6.3TP16VC47M 47uF 20% 16
		C1087	OCE476WF6DC MVK6.3TP16VC47M 47uF 20% 16
		C1088	OCE476WF6DC MVK6.3TP16VC47M 47uF 20% 16
		C1089	OCE476WF6DC MVK6.3TP16VC47M 47uF 20% 16
		C1092	OCE476WF6DC MVK6.3TP16VC47M 47uF 20% 16
		C1101	OCE477WF6DC MVK10TP16VC470M 470uF 20% 1
		C1107	OCE477WF6DC MVK10TP16VC470M 470uF 20% 1
		C1109	OCE477WF6DC MVK10TP16VC470M 470uF 20% 1
		C1110	OCE227WF6DC MVK8.0TP16VC220M 220uF 20%
		C1111	OCE477WF6DC MVK10TP16VC470M 470uF 20% 1
		C1113	OCE227WF6DC MVK8.0TP16VC220M 220uF 20%
		C1128	OCE477WF6DC MVK10TP16VC470M 470uF 20% 1
		C1129	OCE107WF6DC MVK6.3TP16VC100M 100uF 20%
		C1130	OCE107WF6DC MVK6.3TP16VC100M 100uF 20%
		C1131	OCE107WF6DC MVK6.3TP16VC100M 100uF 20%
		C1132	OCE107WF6DC MVK6.3TP16VC100M 100uF 20%
		C1133	OCE107WF6DC MVK6.3TP16VC100M 100uF 20%
		C1135	OCE476WF6DC MVK6.3TP16VC47M 47uF 20% 16
		C1137	OCE476WF6DC MVK6.3TP16VC47M 47uF 20% 16
		C1146	OCE476WF6DC MVK6.3TP16VC47M 47uF 20% 16
		C1147	OCE107WF6DC MVK6.3TP16VC100M 100uF 20%
		C1148	OCE107WF6DC MVK6.3TP16VC100M 100uF 20%
		C1149	OCE107WF6DC MVK6.3TP16VC100M 100uF 20%
		C1151	OCE107WF6DC MVK6.3TP16VC100M 100uF 20%
		C1152	OCE107WF6DC MVK6.3TP16VC100M 100uF 20%

DATE: 2006. 04. 05.			
*S	*AL	LOC. NO.	PART NO. DESCRIPTION / SPECIFICATION
		C1157	OCE476WF6DC MVK6.3TP16VC47M 47uF 20% 16
		C1158	OCE476WF6DC MVK6.3TP16VC47M 47uF 20% 16
		C1207	OCE476SF6DC VMV476M016S0ANC010 47uF 20%
		C1222	OCE106SH6DC VMV106M025S0ANB010 10uF 20%
		C1226	OCE106SH6DC VMV106M025S0ANB010 10uF 20%
		C1244	OCE106SH6DC VMV106M025S0ANB010 10uF 20%
		C1403	OCH8106J691 MVK5.0TP35VC10M 10uF 20% 35
		C1460	OCE106SH6DC VMV106M025S0ANB010 10uF 20%
		C1468	OCE106SH6DC VMV106M025S0ANB010 10uF 20%
		C148	OCE227SF6DC MVG6.3TP16VC220M 220uF 20%
		C149	OCE227SF6DC MVG6.3TP16VC220M 220uF 20%
		C174	OCE106SH6DC VMV106M025S0ANB010 10uF 20%
		C175	OCE106SH6DC VMV106M025S0ANB010 10uF 20%
		C1814	OCE226SF6DC VMV226M016S0ANB010 22uF 20%
		C1826	OCE476SF6DC VMV476M016S0ANC010 47uF 20%
		C211	OCE477SF6DC VMV477M016S0ANG030 470uF 20
		C213	OCE477SF6DC VMV477M016S0ANG030 470uF 20
		C215	OCE106SH6DC VMV106M025S0ANB010 10uF 20%
		C224	OCE477SF6DC VMV477M016S0ANG030 470uF 20
		C227	OCE107SF6DC VMV107M016S0ANE010 100uF 20
		C238	OCE227SF6DC MVG6.3TP16VC220M 220uF 20%
		C314	OCE107SF6DC VMV107M016S0ANE010 100uF 20
		C316	OCE226SF6DC VMV226M016S0ANB010 22uF 20%
		C317	OCE107SF6DC VMV107M016S0ANE010 100uF 20
		C318	OCE476SF6DC VMV476M016S0ANC010 47uF 20%
		C349	OCE476SF6DC VMV476M016S0ANC010 47uF 20%
		C351	OCE105SK6DC VMV105M050S0ANB010 1uF 20%
		C354	OCE105SK6DC VMV105M050S0ANB010 1uF 20%
		C401	OCE476SF6DC VMV476M016S0ANC010 47uF 20%
		C405	OCE107SF6DC VMV107M016S0ANE010 100uF 20
		C409	OCE226SF6DC VMV226M016S0ANB010 22uF 20%
		C412	OCE335SK6DC VMV335M050S0ANB010 3.3uF 20
		C432	OCE106WFKDC MVK4.0TP16VC10M 10uF 20% 16
		C446	OCE335SK6DC VMV335M050S0ANB010 3.3uF 20
		C451	OCE106SH6DC VMV106M025S0ANB010 10uF 20%
		C452	OCE106SH6DC VMV106M025S0ANB010 10uF 20%
		C463	OCE475SK6DC VMV475M050S0ANB010 4.7uF 20
		C464	OCE475SK6DC VMV475M050S0ANB010 4.7uF 20
		C466	OCE475SK6DC VMV475M050S0ANB010 4.7uF 20
		C467	OCE475SK6DC VMV475M050S0ANB010 4.7uF 20
		C512	OCE476SF6DC VMV476M016S0ANC010 47uF 20%
		C611	OCE107SF6DC VMV107M016S0ANE010 100uF 20
		C834	OCE106WFKDC MVK4.0TP16VC10M 10uF 20% 16
		C835	OCE226SF6DC VMV226M016S0ANB010 22uF 20%
		C836	OCE106WFKDC MVK4.0TP16VC10M 10uF 20% 16
		C837	OCE226SF6DC VMV226M016S0ANB010 22uF 20%
		C838	OCE226SF6DC VMV226M016S0ANB010 22uF 20%
		C839	OCE106WFKDC MVK4.0TP16VC10M 10uF 20% 16
		C840	OCE106WFKDC MVK4.0TP16VC10M 10uF 20% 16
		C841	OCE226SF6DC VMV226M016S0ANB010 22uF 20%
		C842	OCE106WFKDC MVK4.0TP16VC10M 10uF 20% 16
		C853	OCE226SF6DC VMV226M016S0ANB010 22uF 20%
		C855	OCE226SF6DC VMV226M016S0ANB010 22uF 20%
		C886	OCE106WFKDC MVK4.0TP16VC10M 10uF 20% 16

DATE: 2006. 04. 05.				
*S	*AL	LOC. NO.	PART NO.	DESCRIPTION / SPECIFICATION
		C898	0CE106WFKDC	MVK4.0TP16VC10M 10uF 20% 16
		C901	0CE226SF6DC	VMV226M016S0ANB010 22uF 20%
		C904	0CE226SF6DC	VMV226M016S0ANB010 22uF 20%
		C905	0CE226SF6DC	VMV226M016S0ANB010 22uF 20%
		C930	0CE226SF6DC	VMV226M016S0ANB010 22uF 20%
		C943	0CE226SF6DC	VMV226M016S0ANB010 22uF 20%
		C950	0CE226SF6DC	VMV226M016S0ANB010 22uF 20%
		C1813	0CE106WFKDC	MVK4.0TP16VC10M 10uF 20% 16
		C1031	0CE476WK6DC	MVK8.0TP50VC47M 47uF 20% 50
		C210	0CE477SF6DC	VMV477M016S0ANG030 470uF 20
		C237	0CE227SF6DC	MVG6.3TP16VC220M 220uF 20%
		C1108	0CE477EK618	KMG5.0TP50VB470M 470uF 20%
		C1112	0CE477EK618	KMG5.0TP50VB470M 470uF 20%
		C1428	0CE477EK618	KMG5.0TP50VB470M 470uF 20%
		C1446	0CE477EK618	KMG5.0TP50VB470M 470uF 20%
		C1003	0CK474CH94A	0603F474Z250CT 470nF -20TO+
		C1026	0CK104CK56A	0603B104K500CT 100nF 10% 50
		C1029	0CK104CK56A	0603B104K500CT 100nF 10% 50
		C1033	0CK104CK56A	0603B104K500CT 100nF 10% 50
		C1034	0CK103CK56A	0603B103K500CT 10nF 10% 50V
		C1036	0CK104CK56A	0603B104K500CT 100nF 10% 50
		C1037	0CK104CK56A	0603B104K500CT 100nF 10% 50
		C1041	0CK103CK56A	0603B103K500CT 10nF 10% 50V
		C1071	0CK104CK56A	0603B104K500CT 100nF 10% 50
		C1117	0CK104CK56A	0603B104K500CT 100nF 10% 50
		C1118	0CK104CK56A	0603B104K500CT 100nF 10% 50
		C1126	0CK103CK56A	0603B103K500CT 10nF 10% 50V
		C1127	0CK103CK56A	0603B103K500CT 10nF 10% 50V
		C1223	0CC180CK41A	C1608C0G1H180JT 18pF 5% 50V
		C1224	0CK103CK56A	0603B103K500CT 10nF 10% 50V
		C1225	0CC180CK41A	C1608C0G1H180JT 18pF 5% 50V
		C1228	0CK103CK51A	0603B103K500CT 10nF 10% 50V
		C1405	0CK104CK56A	0603B104K500CT 100nF 10% 50
		C1419	0CK333CK56A	C1608X7R1H333KT 33nF 10% 50
		C1420	0CK333CK56A	C1608X7R1H333KT 33nF 10% 50
		C1421	0CK333CK56A	C1608X7R1H333KT 33nF 10% 50
		C1422	0CK333CK56A	C1608X7R1H333KT 33nF 10% 50
		C1455	0CK104CK56A	0603B104K500CT 100nF 10% 50
		C1456	0CK104CK56A	0603B104K500CT 100nF 10% 50
		C1457	0CK105DF64A	0805F105Z160CT 1uF -20TO+80
		C1458	0CK105DF64A	0805F105Z160CT 1uF -20TO+80
		C1459	0CK102CK56A	0603B102K500CT 10nF 10% 50V
		C1474	0CC102CK41A	C1608C0G1H102JT 10pF 5% 50V
		C1811	0CK104CK56A	0603B104K500CT 100nF 10% 50
		C1851	0CK104CK56A	0603B104K500CT 100nF 10% 50
		C234	0CC271CK41A	C1608C0G1H271JT 270pF 5% 50
		C312	0CK103CK56A	0603B103K500CT 10nF 10% 50V
		C313	0CK103CK56A	0603B103K500CT 10nF 10% 50V
		C319	0CK104CK56A	0603B104K500CT 100nF 10% 50
		C321	0CK104CK56A	0603B104K500CT 100nF 10% 50
		C322	0CK104CK56A	0603B104K500CT 100nF 10% 50
		C326	0CK225DFK4A	C2012Y5V1C225MT 2.2uF 20% 1
		C327	0CK474CH94A	0603F474Z250CT 470nF -20TO+
		C328	0CK474CH94A	0603F474Z250CT 470nF -20TO+
		C329	0CK225DFK4A	C2012Y5V1C225MT 2.2uF 20% 1
		C330	0CK474CH94A	0603F474Z250CT 470nF -20TO+
		C331	0CK225DFK4A	C2012Y5V1C225MT 2.2uF 20% 1
		C332	0CK474CH94A	0603F474Z250CT 470nF -20TO+
		C333	0CK474CH94A	0603F474Z250CT 470nF -20TO+
		C334	0CK225DFK4A	C2012Y5V1C225MT 2.2uF 20% 1
		C335	0CK474CH94A	0603F474Z250CT 470nF -20TO+
		C336	0CK225DFK4A	C2012Y5V1C225MT 2.2uF 20% 1

DATE: 2006. 04. 05.				
*S	*AL	LOC. NO.	PART NO.	DESCRIPTION / SPECIFICATION
		C337	0CK474CH94A	0603F474Z250CT 470nF -20TO+
		C338	0CK474CH94A	0603F474Z250CT 470nF -20TO+
		C339	0CK225DFK4A	C2012Y5V1C225MT 2.2uF 20% 1
		C340	0CK474CH94A	0603F474Z250CT 470nF -20TO+
		C341	0CK474CH94A	0603F474Z250CT 470nF -20TO+
		C342	0CK225DFK4A	C2012Y5V1C225MT 2.2uF 20% 1
		C343	0CK474CH94A	0603F474Z250CT 470nF -20TO+
		C344	0CK474CH94A	0603F474Z250CT 470nF -20TO+
		C345	0CK225DFK4A	C2012Y5V1C225MT 2.2uF 20% 1
		C346	0CK474CH94A	0603F474Z250CT 470nF -20TO+
		C347	0CK225DFK4A	C2012Y5V1C225MT 2.2uF 20% 1
		C355	0CK821CK56A	C1608X7R1H821KT 820pF 10% 5
		C357	0CK103CK56A	0603B103K500CT 10nF 10% 50V
		C402	0CK103CK56A	0603B103K500CT 10nF 10% 50V
		C403	0CK104CK56A	0603B104K500CT 100nF 10% 50
		C411	0CK104CK56A	0603B104K500CT 100nF 10% 50
		C414	0CC560CK41A	C1608C0G1H560JT 56pF 5% 50V
		C416	0CK103CK56A	0603B103K500CT 10nF 10% 50V
		C428	0CK474CH94A	0603F474Z250CT 470nF -20TO+
		C429	0CK474CH94A	0603F474Z250CT 470nF -20TO+
		C430	0CK474CH94A	0603F474Z250CT 470nF -20TO+
		C431	0CK474CH94A	0603F474Z250CT 470nF -20TO+
		C433	0CK474CH94A	0603F474Z250CT 470nF -20TO+
		C435	0CK474CH94A	0603F474Z250CT 470nF -20TO+
		C438	0CK474CH94A	0603F474Z250CT 470nF -20TO+
		C439	0CK474CH94A	0603F474Z250CT 470nF -20TO+
		C441	0CK474CH94A	0603F474Z250CT 470nF -20TO+
		C442	0CK474CH94A	0603F474Z250CT 470nF -20TO+
		C457	0CK682CK51A	C1608Y5P1H682KT 6.8nF 10% 5
		C458	0CK682CK51A	C1608Y5P1H682KT 6.8nF 10% 5
		C459	0CK682CK51A	C1608Y5P1H682KT 6.8nF 10% 5
		C462	0CK682CK51A	C1608Y5P1H682KT 6.8nF 10% 5
		C494	0CK104CK56A	0603B104K500CT 100nF 10% 50
		C511	0CK104CK56A	0603B104K500CT 100nF 10% 50
		C605	0CK104CK56A	0603B104K500CT 100nF 10% 50
		C606	0CK104CK56A	0603B104K500CT 100nF 10% 50
		C607	0CK104CK56A	0603B104K500CT 100nF 10% 50
		C610	0CK104CK56A	0603B104K500CT 100nF 10% 50
		C800	0CK104CK56A	0603B104K500CT 100nF 10% 50
		C803	0CK104CK56A	0603B104K500CT 100nF 10% 50
		C806	0CK104CK56A	0603B104K500CT 100nF 10% 50
		C812	0CC300CK41A	C1608C0G1H300JT 30pF 5% 50V
		C813	0CC300CK41A	C1608C0G1H300JT 30pF 5% 50V
		C814	0CK104CK56A	0603B104K500CT 100nF 10% 50
		C815	0CK104CK56A	0603B104K500CT 100nF 10% 50
		C817	0CK104CK56A	0603B104K500CT 100nF 10% 50
		C818	0CK104CK56A	0603B104K500CT 100nF 10% 50
		C819	0CK104CK56A	0603B104K500CT 100nF 10% 50
		C820	0CK104CK56A	0603B104K500CT 100nF 10% 50
		C822	0CK104CK56A	0603B104K500CT 100nF 10% 50
		C823	0CK104CK56A	0603B104K500CT 100nF 10% 50
		C824	0CK104CK56A	0603B104K500CT 100nF 10% 50
		C825	0CK104CK56A	0603B104K500CT 100nF 10% 50
		C827	0CK104CK56A	0603B104K500CT 100nF 10% 50
		C828	0CK104CK56A	0603B104K500CT 100nF 10% 50
		C829	0CK104CK56A	0603B104K500CT 100nF 10% 50
		C830	0CK104CK56A	0603B104K500CT 100nF 10% 50
		C831	0CK104CK56A	0603B104K500CT 100nF 10% 50
		C833	0CK104CK56A	0603B104K500CT 100nF 10% 50
		C845	0CK104CK56A	0603B104K500CT 100nF 10% 50
		C868	0CK104CK56A	0603B104K500CT 100nF 10% 50
		C870	0CK103CK56A	0603B103K500CT 10nF 10% 50V



DATE: 2006. 04. 05.				
*S	*AL	LOC. NO.	PART NO.	DESCRIPTION / SPECIFICATION
		C1461	0CK104CK56A	0603B104K500CT 100nF 10% 50
		C1466	0CK104CK56A	0603B104K500CT 100nF 10% 50
		C1467	OCC101CK41A	C1608C0G1H101JT 100pF 5% 50
		C1469	0CK104CK56A	0603B104K500CT 100nF 10% 50
		C147	0CK102CK56A	0603B102K500CT 1nF 10% 50V
		C1470	OCC102CK41A	C1608C0G1H102JT 1nF 5% 50V
		C1473	0CK104CK56A	0603B104K500CT 100nF 10% 50
		C1475	0CK104CK56A	0603B104K500CT 100nF 10% 50
		C1476	0CK104CK56A	0603B104K500CT 100nF 10% 50
		C150	0CK102CK56A	0603B102K500CT 1nF 10% 50V
		C151	0CK103CK56A	0603B103K500CT 10nF 10% 50V
		C152	0CK103CK56A	0603B103K500CT 10nF 10% 50V
		C178	0CK104CK56A	0603B104K500CT 100nF 10% 50
		C1800	0CK104CK56A	0603B104K500CT 100nF 10% 50
		C1801	0CK104CK56A	0603B104K500CT 100nF 10% 50
		C1802	0CK104CK56A	0603B104K500CT 100nF 10% 50
		C1803	0CK103CK56A	0603B103K500CT 10nF 10% 50V
		C1804	0CK104CK56A	0603B104K500CT 100nF 10% 50
		C1805	0CK104CK56A	0603B104K500CT 100nF 10% 50
		C1806	0CK104CK56A	0603B104K500CT 100nF 10% 50
		C1807	0CK104CK56A	0603B104K500CT 100nF 10% 50
		C1808	0CK104CK56A	0603B104K500CT 100nF 10% 50
		C1809	0CK104CK56A	0603B104K500CT 100nF 10% 50
		C1810	0CK104CK56A	0603B104K500CT 100nF 10% 50
		C1812	0CK104CK56A	0603B104K500CT 100nF 10% 50
		C1815	0CK104CK56A	0603B104K500CT 100nF 10% 50
		C1852	0CK104CK56A	0603B104K500CT 100nF 10% 50
		C218	0CK103CK56A	0603B103K500CT 10nF 10% 50V
		C219	OCC680CK41A	C1608C0G1H680JT 68pF 5% 50V
		C220	OCC680CK41A	C1608C0G1H680JT 68pF 5% 50V
		C221	0CK103CK56A	0603B103K500CT 10nF 10% 50V
		C222	0CK103CK56A	0603B103K500CT 10nF 10% 50V
		C223	OCC101CK41A	C1608C0G1H101JT 100pF 5% 50
		C225	0CK273CK56A	0603B273K500CT 27nF 10% 50V
		C226	0CK103CK56A	0603B103K500CT 10nF 10% 50V
		C229	0CK104CK56A	0603B104K500CT 100nF 10% 50
		C231	0CK273CK56A	0603B273K500CT 27nF 10% 50V
		C233	OCC271CK41A	C1608C0G1H271JT 270pF 5% 50
		C315	0CK103CK56A	0603B103K500CT 10nF 10% 50V
		C320	0CK103CK56A	0603B103K500CT 10nF 10% 50V
		C348	0CK104CK56A	0603B104K500CT 100nF 10% 50
		C350	OCC102CK41A	C1608C0G1H102JT 1nF 5% 50V
		C352	0CK563CK56A	C1608X7R1H563KT 56nF 10% 50
		C353	0CK223CK56A	UMK107JB223KA-T 22nF 10% 50
		C356	0CK104CK56A	0603B104K500CT 100nF 10% 50
		C406	0CK104CK56A	0603B104K500CT 100nF 10% 50
		C407	0CH5010K116	0805N1R0D500LT 1pF 0.5PF 50
		C408	0CH5010K116	0805N1R0D500LT 1pF 0.5PF 50
		C415	OCC560CK41A	C1608C0G1H560JT 56pF 5% 50V
		C434	0CK104CK56A	0603B104K500CT 100nF 10% 50
		C436	0CK103CK56A	0603B103K500CT 10nF 10% 50V
		C437	OCC101CK41A	C1608C0G1H101JT 100pF 5% 50
		C444	0CK103CK56A	0603B103K500CT 10nF 10% 50V
		C445	0CK471CK56A	C1608X7R1H471KT 470pF 10% 5
		C469	0CK104CK56A	0603B104K500CT 100nF 10% 50
		C479	0CK471CK56A	C1608X7R1H471KT 470pF 10% 5
		C483	0CK471CK56A	C1608X7R1H471KT 470pF 10% 5
		C493	0CK102CK56A	0603B102K500CT 1nF 10% 50V
		C495	0CK102CK56A	0603B102K500CT 1nF 10% 50V
		C502	0CK103CK56A	0603B103K500CT 10nF 10% 50V
		C503	0CK103CK56A	0603B103K500CT 10nF 10% 50V
		C506	OCC120CK41A	C1608C0G1H120JT 12pF 5% 50V

DATE: 2006. 04. 05.				
*S	*AL	LOC. NO.	PART NO.	DESCRIPTION / SPECIFICATION
		C514	0CK104CK56A	0603B104K500CT 100nF 10% 50
		C603	OCC221CK41A	C1608C0G1H221JT 220pF 5% 50
		C608	0CK104CK56A	0603B104K500CT 100nF 10% 50
		C609	OCC470CK41A	C1608C0G1H470JT 47pF 5% 50V
		C624	0CK104CK56A	0603B104K500CT 100nF 10% 50
		C816	0CK104CK56A	0603B104K500CT 100nF 10% 50
		C821	0CK104CK56A	0603B104K500CT 100nF 10% 50
		C826	0CK104CK56A	0603B104K500CT 100nF 10% 50
		C843	0CK104CK56A	0603B104K500CT 100nF 10% 50
		C844	0CK104CK56A	0603B104K500CT 100nF 10% 50
		C846	0CK104CK56A	0603B104K500CT 100nF 10% 50
		C847	0CK103CK56A	0603B103K500CT 10nF 10% 50V
		C848	0CK104CK56A	0603B104K500CT 100nF 10% 50
		C849	0CK104CK56A	0603B104K500CT 100nF 10% 50
		C850	0CK104CK56A	0603B104K500CT 100nF 10% 50
		C851	0CK103CK56A	0603B103K500CT 10nF 10% 50V
		C852	0CK104CK56A	0603B104K500CT 100nF 10% 50
		C854	0CK104CK56A	0603B104K500CT 100nF 10% 50
		C856	0CK104CK56A	0603B104K500CT 100nF 10% 50
		C857	0CK104CK56A	0603B104K500CT 100nF 10% 50
		C858	0CK104CK56A	0603B104K500CT 100nF 10% 50
		C859	0CK104CK56A	0603B104K500CT 100nF 10% 50
		C860	0CK104CK56A	0603B104K500CT 100nF 10% 50
		C861	0CK104CK56A	0603B104K500CT 100nF 10% 50
		C862	0CK103CK56A	0603B103K500CT 10nF 10% 50V
		C863	0CK104CK56A	0603B104K500CT 100nF 10% 50
		C864	0CK104CK56A	0603B104K500CT 100nF 10% 50
		C865	0CK104CK56A	0603B104K500CT 100nF 10% 50
		C866	0CK104CK56A	0603B104K500CT 100nF 10% 50
		C867	0CK104CK56A	0603B104K500CT 100nF 10% 50
		C869	0CK104CK56A	0603B104K500CT 100nF 10% 50
		C871	0CK104CK56A	0603B104K500CT 100nF 10% 50
		C872	0CK104CK56A	0603B104K500CT 100nF 10% 50
		C873	0CK104CK56A	0603B104K500CT 100nF 10% 50
		C875	0CK104CK56A	0603B104K500CT 100nF 10% 50
		C876	0CK103CK56A	0603B103K500CT 10nF 10% 50V
		C877	0CK104CK56A	0603B104K500CT 100nF 10% 50
		C878	0CK104CK56A	0603B104K500CT 100nF 10% 50
		C879	0CK104CK56A	0603B104K500CT 100nF 10% 50
		C880	0CK104CK56A	0603B104K500CT 100nF 10% 50
		C882	0CK104CK56A	0603B104K500CT 100nF 10% 50
		C883	0CK104CK56A	0603B104K500CT 100nF 10% 50
		C884	0CK103CK56A	0603B103K500CT 10nF 10% 50V
		C885	0CK104CK56A	0603B104K500CT 100nF 10% 50
		C887	0CK104CK56A	0603B104K500CT 100nF 10% 50
		C888	0CK104CK56A	0603B104K500CT 100nF 10% 50
		C889	0CK104CK56A	0603B104K500CT 100nF 10% 50
		C890	0CK104CK56A	0603B104K500CT 100nF 10% 50
		C891	0CK104CK56A	0603B104K500CT 100nF 10% 50
		C892	0CK103CK56A	0603B103K500CT 10nF 10% 50V
		C893	0CK104CK56A	0603B104K500CT 100nF 10% 50
		C894	0CK104CK56A	0603B104K500CT 100nF 10% 50
		C895	0CK104CK56A	0603B104K500CT 100nF 10% 50
		C896	0CK104CK56A	0603B104K500CT 100nF 10% 50
		C897	0CK104CK56A	0603B104K500CT 100nF 10% 50
		C899	0CK104CK56A	0603B104K500CT 100nF 10% 50
		C902	0CK104CK56A	0603B104K500CT 100nF 10% 50
		C903	0CK103CK56A	0603B103K500CT 10nF 10% 50V
		C906	0CK104CK56A	0603B104K500CT 100nF 10% 50
		C907	0CK103CK56A	0603B103K500CT 10nF 10% 50V
		C908	0CK104CK56A	0603B104K500CT 100nF 10% 50
		C909	0CK103CK56A	0603B103K500CT 10nF 10% 50V

DATE: 2006. 04. 05.				
*S	*AL	LOC. NO.	PART NO.	DESCRIPTION / SPECIFICATION
		C910	0CK104CK56A	0603B104K500CT 100nF 10% 50
		C911	0CK103CK56A	0603B103K500CT 10nF 10% 50V
		C912	0CK104CK56A	0603B104K500CT 100nF 10% 50
		C913	0CK103CK56A	0603B103K500CT 10nF 10% 50V
		C914	0CK104CK56A	0603B104K500CT 100nF 10% 50
		C915	0CK103CK56A	0603B103K500CT 10nF 10% 50V
		C916	0CK104CK56A	0603B104K500CT 100nF 10% 50
		C917	0CK103CK56A	0603B103K500CT 10nF 10% 50V
		C918	0CK104CK56A	0603B104K500CT 100nF 10% 50
		C919	0CK103CK56A	0603B103K500CT 10nF 10% 50V
		C920	0CK104CK56A	0603B104K500CT 100nF 10% 50
		C921	0CK103CK56A	0603B103K500CT 10nF 10% 50V
		C922	0CK104CK56A	0603B104K500CT 100nF 10% 50
		C923	0CK103CK56A	0603B103K500CT 10nF 10% 50V
		C924	0CK104CK56A	0603B104K500CT 100nF 10% 50
		C925	0CK103CK56A	0603B103K500CT 10nF 10% 50V
		C926	0CK104CK56A	0603B104K500CT 100nF 10% 50
		C927	0CK103CK56A	0603B103K500CT 10nF 10% 50V
		C928	0CK104CK56A	0603B104K500CT 100nF 10% 50
		C929	0CK103CK56A	0603B103K500CT 10nF 10% 50V
		C931	0CK104CK56A	0603B104K500CT 100nF 10% 50
		C932	0CK103CK56A	0603B103K500CT 10nF 10% 50V
		C933	0CK104CK56A	0603B104K500CT 100nF 10% 50
		C934	0CK103CK56A	0603B103K500CT 10nF 10% 50V
		C935	0CK104CK56A	0603B104K500CT 100nF 10% 50
		C936	0CK103CK56A	0603B103K500CT 10nF 10% 50V
		C937	0CK104CK56A	0603B104K500CT 100nF 10% 50
		C938	0CK103CK56A	0603B103K500CT 10nF 10% 50V
		C939	0CK104CK56A	0603B104K500CT 100nF 10% 50
		C940	0CK103CK56A	0603B103K500CT 10nF 10% 50V
		C941	0CK104CK56A	0603B104K500CT 100nF 10% 50
		C942	0CK103CK56A	0603B103K500CT 10nF 10% 50V
		C944	0CK104CK56A	0603B104K500CT 100nF 10% 50
		C949	0CK103CK56A	0603B103K500CT 10nF 10% 50V
		C951	0CK104CK56A	0603B104K500CT 100nF 10% 50
		C1827	0CK471CK56A	C1608X7R1H471KT 470pF 10% 5
		C1828	0CK471CK56A	C1608X7R1H471KT 470pF 10% 5
		C1829	0CK471CK56A	C1608X7R1H471KT 470pF 10% 5
		C1830	0CK471CK56A	C1608X7R1H471KT 470pF 10% 5
		C1831	0CK471CK56A	C1608X7R1H471KT 470pF 10% 5
		C805	0CK471CK56A	C1608X7R1H471KT 470pF 10% 5
		C809	0CK104CK56A	0603B104K500CT 100nF 10% 50
		C810	0CK104CK56A	0603B104K500CT 100nF 10% 50
		C1032	0CK104CK56A	0603B104K500CT 100nF 10% 50
		C200	0CC331CK41A	C1608C0G1H331JT 330pF 5% 50
		C201	0CK103CK56A	0603B103K500CT 10nF 10% 50V
		C206	0CK103CK56A	0603B103K500CT 10nF 10% 50V
		C207	0CC680CK41A	C1608C0G1H680JT 68pF 5% 50V
		C208	0CC680CK41A	C1608C0G1H680JT 68pF 5% 50V
		C209	0CK103CK56A	0603B103K500CT 10nF 10% 50V
		C228	0CC271CK41A	C1608C0G1H271JT 270pF 5% 50
		C1426	0CF4741L438	PCMT 365 76474 470nF 5% 63V
		C1427	0CF4741L438	PCMT 365 76474 470nF 5% 63V
<b>DIODES</b>				
		D1201	0DD184009AA	KDS184 KDS184 TP KEC - 85V
		D1007	0DD200009AF	RU2M 400V 1.2V 10UA 20A 400
		D1008	0DD200009AF	RU2M 400V 1.2V 10UA 20A 400
		D300	0DS226009AA	KDS226 1.2V 85V 300MA 2A 4N
		D500	0DS226009AA	KDS226 1.2V 85V 300MA 2A 4N
		D501	0DS226009AA	KDS226 1.2V 85V 300MA 2A 4N

DATE: 2006. 04. 05.				
*S	*AL	LOC. NO.	PART NO.	DESCRIPTION / SPECIFICATION
		D502	0DS226009AA	KDS226 1.2V 85V 300MA 2A 4N
		D1000	0DS226009AA	KDS226 1.2V 85V 300MA 2A 4N
		D1001	0DS226009AA	KDS226 1.2V 85V 300MA 2A 4N
		D1002	0DS226009AA	KDS226 1.2V 85V 300MA 2A 4N
		D1004	0DS226009AA	KDS226 1.2V 85V 300MA 2A 4N
		D1005	0DS226009AA	KDS226 1.2V 85V 300MA 2A 4N
		D1006	0DS226009AA	KDS226 1.2V 85V 300MA 2A 4N
		D1100	0DS226009AA	KDS226 1.2V 85V 300MA 2A 4N
		D1101	0DS226009AA	KDS226 1.2V 85V 300MA 2A 4N
		D1102	0DS226009AA	KDS226 1.2V 85V 300MA 2A 4N
		D114	0DS226009AA	KDS226 1.2V 85V 300MA 2A 4N
		D115	0DS226009AA	KDS226 1.2V 85V 300MA 2A 4N
		D1204	0DRSE00048A	RLCAMP0504M 1.2V 6V 25V 12A
		D1205	0DRSE00048A	RLCAMP0504M 1.2V 6V 25V 12A
		ZD501	0DR050008AA	SD05.TC - 6V 14.5V 24A 350W
		ZD502	0DR050008AA	SD05.TC - 6V 14.5V 24A 350W
		ZD503	0DR050008AA	SD05.TC - 6V 14.5V 24A 350W
		ZD600	0DR050008AA	SD05.TC - 6V 14.5V 24A 350W
		ZD400	0DXRM00248A	RLZ8.2B 8.2V 7.78TO8.19V 80
<b>IC</b>				
		IC300	0ISO206900A	CXA2069Q 8.5TO9.5V -- 1300
		IC402	0IMCRT1028C	TAS5122DCARG4,LF 3TO3.6V_16"
		IC403	0IPH741400E	74HC14D 2TO6V 0.002mA SCHMI
		IC501	0IPH741400E	74HC14D 2TO6V 0.002mA SCHMI
		IC900	0IMMRAL016D	AT49BV160C-70TU 16MBIT 1MX1
		IC800	0IPRP00692B	FLI8662-LF-AB-XD --- PBGA
		IC901	0IMMRHY052C	HY5DU281622ETP-5 128MBIT 2M-CKD
		IC901	0IMMR00002A	K4D261638F-LC50 128MBIT 8MX-SKD
		IC902	0IMMRHY052C	HY5DU281622ETP-5 128MBIT 2M-CKD
		IC902	0IMMR00002A	K4D261638F-LC50 128MBIT 8MX-SKD
		IC1202	0IMMRAL014B	AT24C02N-10SI-2.7 2KBIT 256-CKD
		IC1202	0IMMRAL014C	AT24C02N-10SU-2.7 2KBIT 256-SKD
		IC500	0IMMRAL014B	AT24C02N-10SI-2.7 2KBIT 256-CKD
		IC500	0IMMRAL014C	AT24C02N-10SU-2.7 2KBIT 256-SKD
		IC802	0IMP242560A	24LC256-I/SM 256KBIT 32KX8B
		IC1200	0IPRP00735A	ANX9021 3.3V - 17MHZ TQFP T
		IC1000	0IPRPML001C	"MIC39100-2.5WS,LF 2.3TO26V-CKD
		IC1000	0IPRPML001A	MIC39100 2.3TO26V -- SOT22-SKD
		IC1001	0IPMGRH001G	BA33BC0FP-E2 4.3TO16V 3.3V
		IC1003	0IPMG00027A	SC156515M-1.8TR 2.2TO5.5V 1
		IC1004	0IPMGRH001G	BA33BC0FP-E2 4.3TO16V 3.3V
		IC1005	0IPMGRH001G	BA33BC0FP-E2 4.3TO16V 3.3V
		IC1100	0IPMGKE030A	KIA78R05F 6TO12V 5V 8W DPAK
		IC1101	0IPRPML001C	"MIC39100-2.5WS,LF 2.3TO26V-CKD
		IC1101	0IPRPML001A	MIC39100 2.3TO26V -- SOT22-SKD
		IC1102	0IPMG00027A	SC156515M-1.8TR 2.2TO5.5V 1
		IC400	0IMCRMN028C	MSP4450K-QA-D6 7.6TO8.7V_4.
		IC401	0IPRP00718A	NTP-2000 2.0TO5.0V - LQFP T
		IC600	0IPRP00009A	ICL3232CBNZ 3.0TO5.5 - SSOP
		IC301	0ISA721700C	LA7217M 4.5VTO5.5V 16.1KHZ
		IC1002	0IMCRFA010A	KA7809R 11.5TO24V 9V 150W D
<b>COIL &amp; CORE &amp; INDUCTOR</b>				
		L1000	6140VB0004B	LN-15A1 26uH -- 12X9MM LEA
		L1101	6140VB0004B	LN-15A1 26uH -- 12X9MM LEA
		L1105	6140VB0004B	LN-15A1 26uH -- 12X9MM LEA
		L1106	6140VB0004B	LN-15A1 26uH -- 12X9MM LEA
		L1107	6140VB0004B	LN-15A1 26uH -- 12X9MM LEA
		L1110	6140VB0004B	LN-15A1 26uH -- 12X9MM LEA





DATE: 2006. 04. 05.				
*S	*AL	LOC. NO.	PART NO.	DESCRIPTION / SPECIFICATION
		L207	0LC6461201A	D75C-646CY-121M=P3 120UH 20
		L120	0LCML00020G	MLI-201209-3R3K 3.3UH 10% -
		L121	0LCML00020G	MLI-201209-3R3K 3.3UH 10% -
		L122	0LCML00020G	MLI-201209-3R3K 3.3UH 10% -
		L123	0LCML00020G	MLI-201209-3R3K 3.3UH 10% -
		L206	0LCML00020G	MLI-201209-3R3K 3.3UH 10% -
		L311	0LCML00020C	MLI-201212-100K 10UH 10% -
		L407	0LCML00020C	MLI-201212-100K 10UH 10% -
		L408	0LCML00020C	MLI-201212-100K 10UH 10% -
		L204	0LCML00020G	MLI-201209-3R3K 3.3UH 10% -
FET & TRANSISTOR				
		IC1205	0TR830009BA	BSS83 N-CHANNEL MOSFET 10V
		IC1206	0TR830009BA	BSS83 N-CHANNEL MOSFET 10V
		IC1006	0TF492509AA	SI4925DY P-CHANNEL -30V +2
		Q1000	0TR387500AA	2SC3875S(ALY) NPN 5V 60V 50
		Q1001	0TR387500AA	2SC3875S(ALY) NPN 5V 60V 50
		Q1004	0TR387500AA	2SC3875S(ALY) NPN 5V 60V 50
		Q1005	0TR387500AA	2SC3875S(ALY) NPN 5V 60V 50
		Q1201	0TR387500AA	2SC3875S(ALY) NPN 5V 60V 50
		Q212	0TR387500AA	2SC3875S(ALY) NPN 5V 60V 50
		Q300	0TR387500AA	2SC3875S(ALY) NPN 5V 60V 50
		Q301	0TR387500AA	2SC3875S(ALY) NPN 5V 60V 50
		Q302	0TR387500AA	2SC3875S(ALY) NPN 5V 60V 50
		Q303	0TR387500AA	2SC3875S(ALY) NPN 5V 60V 50
		Q304	0TR387500AA	2SC3875S(ALY) NPN 5V 60V 50
		Q400	0TR387500AA	2SC3875S(ALY) NPN 5V 60V 50
		Q401	0TR387500AA	2SC3875S(ALY) NPN 5V 60V 50
		Q402	0TR387500AA	2SC3875S(ALY) NPN 5V 60V 50
		Q404	0TR387500AA	2SC3875S(ALY) NPN 5V 60V 50
		Q408	0TR102009AM	KRA102S PNP -30V -50V -0.
		Q410	0TR387500AA	2SC3875S(ALY) NPN 5V 60V 50
		Q411	0TR387500AA	2SC3875S(ALY) NPN 5V 60V 50
		Q600	0TR387500AA	2SC3875S(ALY) NPN 5V 60V 50
		Q105	0TR387500AA	2SC3875S(ALY) NPN 5V 60V 50
		Q106	0TR387500AA	2SC3875S(ALY) NPN 5V 60V 50
		Q107	0TR102009AM	KRA102S PNP -30V -50V -0.
		Q201	0TR387500AA	2SC3875S(ALY) NPN 5V 60V 50
		Q202	0TR150400BA	2SA1504S(ASY) PNP -5V -50V
		Q203	0TR387500AA	2SC3875S(ALY) NPN 5V 60V 50
		Q204	0TR150400BA	2SA1504S(ASY) PNP -5V -50V
		Q205	0TR387500AA	2SC3875S(ALY) NPN 5V 60V 50
		Q206	0TR150400BA	2SA1504S(ASY) PNP -5V -50V
		Q207	0TR150400BA	2SA1504S(ASY) PNP -5V -50V
		Q305	0TR150400BA	2SA1504S(ASY) PNP -5V -50V
		Q403	0TR387500AA	2SC3875S(ALY) NPN 5V 60V 50
		Q405	0TR102009AM	KRA102S PNP -30V -50V -0.
		Q407	0TR387500AA	2SC3875S(ALY) NPN 5V 60V 50
		Q409	0TR387500AA	2SC3875S(ALY) NPN 5V 60V 50
		Q801	0TR150400BA	2SA1504S(ASY) PNP -5V -50V
		Q800	0TR102009AJ	KRC102S NPN 30V - 50V 100MA
		Q1006	0TR387500AA	2SC3875S(ALY) NPN 5V 60V 50
		Q211	0TR387500AA	2SC3875S(ALY) NPN 5V 60V 50
		Q200	0TR150400BA	2SA1504S(ASY) PNP -5V -50V
RESISTORS				
		AR800	0RJ0332C687	RCA86TRJ33R0 330OHM 5% 1/16W
		AR801	0RJ0332C687	RCA86TRJ33R0 330OHM 5% 1/16W
		AR802	0RJ0332C687	RCA86TRJ33R0 330OHM 5% 1/16W
		AR803	0RJ0332C687	RCA86TRJ33R0 330OHM 5% 1/16W

DATE: 2006. 04. 05.				
*S	*AL	LOC. NO.	PART NO.	DESCRIPTION / SPECIFICATION
		AR804	0RJ0332C687	RCA86TRJ33R0 330OHM 5% 1/16W
		AR805	0RJ0332C687	RCA86TRJ33R0 330OHM 5% 1/16W
		AR806	0RJ0332C687	RCA86TRJ33R0 330OHM 5% 1/16W
		AR807	0RJ0332C687	RCA86TRJ33R0 330OHM 5% 1/16W
		R226	0RD0331H609	RD-92T1J3R30 3.3OHM 5% 1/2W
		C832	0CK104CK56A	0603B104K500CT 100nF 10% 50-CKD
		C832	0RJ0000D677	MCR03EJPJ000 0OHM 5% 1/10W-SKD
		L1853	0RJ0000D677	MCR03EJPJ000 0OHM 5% 1/10W
		L1856	0RJ0000D677	MCR03EJPJ000 0OHM 5% 1/10W
		R1002	0RJ1801D677	MCR03EJPJ182 1.8KOHM 5% 1/1
		R1003	0RJ4701D677	MCR03EJPJ472 4.7KOHM 5% 1/1
		R1005	0RJ2000D677	MCR03EJPJ201 200OHM 5% 1/10
		R1010	0RJ1002D677	MCR03EJPJ103 10KOHM 5% 1/10
		R1012	0RJ1002D677	MCR03EJPJ103 10KOHM 5% 1/10
		R1015	0RJ1002D677	MCR03EJPJ103 10KOHM 5% 1/10
		R1016	0RJ1002D677	MCR03EJPJ103 10KOHM 5% 1/10
		R1017	0RJ1002D677	MCR03EJPJ103 10KOHM 5% 1/10
		R1019	0RJ1002D677	MCR03EJPJ103 10KOHM 5% 1/10
		R1020	0RJ1002D677	MCR03EJPJ103 10KOHM 5% 1/10
		R1021	0RJ2002D677	MCR03EJPJ203. 20KOHM 5% 1/1
		R1100	0RJ1002D677	MCR03EJPJ103 10KOHM 5% 1/10
		R1101	0RJ1201D677	MCR03EJPJ122 1.2KOHM 5% 1/1
		R1200	0RJ1002D677	MCR03EJPJ103 10KOHM 5% 1/10
		R1206	0RJ1001D677	MCR03EJPJ102 1KOHM 5% 1/10W
		R1210	0RJ0332D677	MCR03EJPJ330 330OHM 5% 1/10W
		R1215	0RJ0102D677	MCR03EJPJ100 10OHM 5% 1/10W
		R1216	0RJ0102D677	MCR03EJPJ100 10OHM 5% 1/10W
		R1217	0RJ0102D677	MCR03EJPJ100 10OHM 5% 1/10W
		R1218	0RJ0102D677	MCR03EJPJ100 10OHM 5% 1/10W
		R1219	0RJ0102D677	MCR03EJPJ100 10OHM 5% 1/10W
		R1220	0RJ0102D677	MCR03EJPJ100 10OHM 5% 1/10W
		R1221	0RJ0102D677	MCR03EJPJ100 10OHM 5% 1/10W
		R1222	0RJ0102D677	MCR03EJPJ100 10OHM 5% 1/10W
		R1237	0RJ1000D677	MCR03EJPJ101 100OHM 5% 1/10
		R1238	0RJ1000D677	MCR03EJPJ101 100OHM 5% 1/10
		R1251	0RJ1502D677	MCR03EJPJ153 15KOHM 5% 1/10
		R1253	0RJ1502D677	MCR03EJPJ153 15KOHM 5% 1/10
		R1257	0RJ0222D677	MCR03EJPJ220 22OHM 5% 1/10W
		R1258	0RJ0222D677	MCR03EJPJ220 22OHM 5% 1/10W
		R1261	0RJ0222D677	MCR03EJPJ220 22OHM 5% 1/10W
		R1263	0RJ0332D677	MCR03EJPJ330 330OHM 5% 1/10W
		R1264	0RJ0332D677	MCR03EJPJ330 330OHM 5% 1/10W
		R1265	0RJ0332D677	MCR03EJPJ330 330OHM 5% 1/10W
		R1266	0RJ1004D677	MCR03EJPJ105 1MOHM 5% 1/10W
		R1267	0RJ1820D477	MCR03EJPF1820 1820OHM 1% 1/1
		R1268	0RJ4701D677	MCR03EJPJ472 4.7KOHM 5% 1/1
		R1269	0RJ0000D677	MCR03EJPJ000 0OHM 5% 1/10W
		R1272	0RJ0222D677	MCR03EJPJ220 22OHM 5% 1/10W
		R1274	0RJ0222D677	MCR03EJPJ220 22OHM 5% 1/10W
		R1275	0RJ0222D677	MCR03EJPJ220 22OHM 5% 1/10W
		R1276	0RJ0222D677	MCR03EJPJ220 22OHM 5% 1/10W
		R1279	0RJ1001D677	MCR03EJPJ102 1KOHM 5% 1/10W
		R1280	0RJ2001D677	MCR03EJPJ202 2KOHM 5% 1/10W
		R1406	0RJ0101D677	MCR03EJPJ1R0 1OHM 5% 1/10W
		R1413	0RJ0221D677	MCR03EJPJ2R2 2.2OHM 5% 1/10
		R1414	0RJ0221D677	MCR03EJPJ2R2 2.2OHM 5% 1/10
		R1415	0RJ0221D677	MCR03EJPJ2R2 2.2OHM 5% 1/10
		R1416	0RJ0221D677	MCR03EJPJ2R2 2.2OHM 5% 1/10
		R1438	0RJ0222D677	MCR03EJPJ220 22OHM 5% 1/10W
		R1439	0RJ1000D677	MCR03EJPJ101 100OHM 5% 1/10
		R1440	0RJ1000D677	MCR03EJPJ101 100OHM 5% 1/10
		R1441	0RJ0000D677	MCR03EJPJ000 0OHM 5% 1/10W

DATE: 2006. 04. 05.				
*S	*AL	LOC. NO.	PART NO.	DESCRIPTION / SPECIFICATION
		R1442	0RJ0000D677	MCR03EZPJ000 0OHM 5% 1/10W
		R1447	0RJ4701D677	MCR03EZPJ472 4.7KOHM 5% 1/1
		R1450	0RJ0222D677	MCR03EZPJ220 22OHM 5% 1/10W
		R1451	0RJ0222D677	MCR03EZPJ220 22OHM 5% 1/10W
		R1452	0RJ0222D677	MCR03EZPJ220 22OHM 5% 1/10W
		R1458	0RJ1000D677	MCR03EZPJ101 100OHM 5% 1/10
		R1460	0RJ0000D677	MCR03EZPJ000 0OHM 5% 1/10W
		R1461	0RJ0000D677	MCR03EZPJ000 0OHM 5% 1/10W
		R1463	0RJ0000D677	MCR03EZPJ000 0OHM 5% 1/10W
		R1465	0RJ0000D677	MCR03EZPJ000 0OHM 5% 1/10W
		R1466	0RJ0000D677	MCR03EZPJ000 0OHM 5% 1/10W
		R1469	0RJ0000D677	MCR03EZPJ000 0OHM 5% 1/10W
		R1802	0RJ1002D677	MCR03EZPJ103 10KOHM 5% 1/10
		R1803	0RJ1002D677	MCR03EZPJ103 10KOHM 5% 1/10
		R1807	0RJ1002D677	MCR03EZPJ103 10KOHM 5% 1/10
		R1808	0RJ1002D677	MCR03EZPJ103 10KOHM 5% 1/10
		R1814	0RJ0000D677	MCR03EZPJ000 0OHM 5% 1/10W
		R1815	0RJ0000D677	MCR03EZPJ000 0OHM 5% 1/10W
		R1816	0RJ0000D677	MCR03EZPJ000 0OHM 5% 1/10W
		R1817	0RJ0000D677	MCR03EZPJ000 0OHM 5% 1/10W
		R1818	0RJ0000D677	MCR03EZPJ000 0OHM 5% 1/10W
		R1819	0RJ0000D677	MCR03EZPJ000 0OHM 5% 1/10W
		R1820	0RJ0000D677	MCR03EZPJ000 0OHM 5% 1/10W
		R1821	0RJ0000D677	MCR03EZPJ000 0OHM 5% 1/10W
		R1822	0RJ0000D677	MCR03EZPJ000 0OHM 5% 1/10W
		R1823	0RJ0000D677	MCR03EZPJ000 0OHM 5% 1/10W
		R1825	0RJ0000D677	MCR03EZPJ000 0OHM 5% 1/10W
		R1866	0RJ1002D677	MCR03EZPJ103 10KOHM 5% 1/10
		R1867	0RJ1002D677	MCR03EZPJ103 10KOHM 5% 1/10
		R1889	0RJ0222D677	MCR03EZPJ220 22OHM 5% 1/10W
		R247	0RJ1002D677	MCR03EZPJ103 10KOHM 5% 1/10
		R306	0RJ1000D677	MCR03EZPJ101 100OHM 5% 1/10
		R311	0RJ2200D677	MCR03EZPJ221 220OHM 5% 1/10
		R312	0RJ2200D677	MCR03EZPJ221 220OHM 5% 1/10
		R313	0RJ2200D677	MCR03EZPJ221 220OHM 5% 1/10
		R314	0RJ2200D677	MCR03EZPJ221 220OHM 5% 1/10
		R315	0RJ1001D677	MCR03EZPJ102 1KOHM 5% 1/10W
		R316	0RJ1001D677	MCR03EZPJ102 1KOHM 5% 1/10W
		R317	0RJ1000D677	MCR03EZPJ101 100OHM 5% 1/10
		R318	0RJ1000D677	MCR03EZPJ101 100OHM 5% 1/10
		R319	0RJ1001D677	MCR03EZPJ102 1KOHM 5% 1/10W
		R320	0RJ1001D677	MCR03EZPJ102 1KOHM 5% 1/10W
		R322	0RJ1003D677	MCR03EZPJ104 100KOHM 5% 1/1
		R323	0RJ2200D677	MCR03EZPJ221 220OHM 5% 1/10
		R324	0RJ2200D677	MCR03EZPJ221 220OHM 5% 1/10
		R326	0RJ1000D677	MCR03EZPJ101 100OHM 5% 1/10
		R329	0RJ1000D677	MCR03EZPJ101 100OHM 5% 1/10
		R330	0RJ1000D677	MCR03EZPJ101 100OHM 5% 1/10
		R333	0RJ1000D677	MCR03EZPJ101 100OHM 5% 1/10
		R334	0RJ1201D677	MCR03EZPJ122 1.2KOHM 5% 1/1
		R335	0RJ1000D677	MCR03EZPJ101 100OHM 5% 1/10
		R336	0RJ1201D677	MCR03EZPJ122 1.2KOHM 5% 1/1
		R337	0RJ1000D677	MCR03EZPJ101 100OHM 5% 1/10
		R338	0RJ1002D677	MCR03EZPJ103 10KOHM 5% 1/10
		R339	0RJ1000D677	MCR03EZPJ101 100OHM 5% 1/10
		R340	0RJ1201D677	MCR03EZPJ122 1.2KOHM 5% 1/1
		R341	0RJ1000D677	MCR03EZPJ101 100OHM 5% 1/10
		R342	0RJ1201D677	MCR03EZPJ122 1.2KOHM 5% 1/1
		R343	0RJ1000D677	MCR03EZPJ101 100OHM 5% 1/10
		R344	0RJ1001D677	MCR03EZPJ102 1KOHM 5% 1/10W
		R345	0RJ1000D677	MCR03EZPJ101 100OHM 5% 1/10
		R346	0RJ1201D677	MCR03EZPJ122 1.2KOHM 5% 1/1

DATE: 2006. 04. 05.				
*S	*AL	LOC. NO.	PART NO.	DESCRIPTION / SPECIFICATION
		R347	0RJ1000D677	MCR03EZPJ101 100OHM 5% 1/10
		R348	0RJ1201D677	MCR03EZPJ122 1.2KOHM 5% 1/1
		R349	0RJ1000D677	MCR03EZPJ101 100OHM 5% 1/10
		R350	0RJ1001D677	MCR03EZPJ102 1KOHM 5% 1/10W
		R352	0RJ1201D677	MCR03EZPJ122 1.2KOHM 5% 1/1
		R354	0RJ1201D677	MCR03EZPJ122 1.2KOHM 5% 1/1
		R355	0RJ1000D677	MCR03EZPJ101 100OHM 5% 1/10
		R356	0RJ1000D677	MCR03EZPJ101 100OHM 5% 1/10
		R357	0RJ1000D677	MCR03EZPJ101 100OHM 5% 1/10
		R358	0RJ1000D677	MCR03EZPJ101 100OHM 5% 1/10
		R359	0RJ1000D677	MCR03EZPJ101 100OHM 5% 1/10
		R360	0RJ1003D677	MCR03EZPJ104 100KOHM 5% 1/1
		R361	0RJ1000D677	MCR03EZPJ101 100OHM 5% 1/10
		R362	0RJ1000D677	MCR03EZPJ101 100OHM 5% 1/10
		R371	0RJ5600D677	MCR03EZPJ561 560OHM 5% 1/10
		R372	0RJ0472D677	MCR03EZPJ470 47OHM 5% 1/10W
		R376	0RJ3901D677	MCR03EZPJ392 3.9KOHM 5% 1/1
		R400	0RJ0000D677	MCR03EZPJ000 0OHM 5% 1/10W
		R410	0RJ0622D677	MCR03EZPJ620 62OHM 5% 1/10W
		R411	0RJ2402D677	MCR03EZPJ243 24KOHM 5% 1/10
		R412	0RJ1501D677	MCR03EZPJ152 1.5KOHM 5% 1/1
		R413	0RJ4700D677	MCR03EZPJ471 470OHM 5% 1/10
		R425	0RJ1000D677	MCR03EZPJ101 100OHM 5% 1/10
		R426	0RJ1000D677	MCR03EZPJ101 100OHM 5% 1/10
		R427	0RJ1000D677	MCR03EZPJ101 100OHM 5% 1/10
		R428	0RJ1000D677	MCR03EZPJ101 100OHM 5% 1/10
		R429	0RJ0222D677	MCR03EZPJ220 22OHM 5% 1/10W
		R430	0RJ0222D677	MCR03EZPJ220 22OHM 5% 1/10W
		R431	0RJ0222D677	MCR03EZPJ220 22OHM 5% 1/10W
		R432	0RJ0222D677	MCR03EZPJ220 22OHM 5% 1/10W
		R436	0RJ0000D677	MCR03EZPJ000 0OHM 5% 1/10W
		R437	0RJ0000D677	MCR03EZPJ000 0OHM 5% 1/10W
		R438	0RJ0000D677	MCR03EZPJ000 0OHM 5% 1/10W
		R444	0RJ1001D677	MCR03EZPJ102 1KOHM 5% 1/10W
		R451	0RJ1000D677	MCR03EZPJ101 100OHM 5% 1/10
		R452	0RJ1001D677	MCR03EZPJ102 1KOHM 5% 1/10W
		R453	0RJ1001D677	MCR03EZPJ102 1KOHM 5% 1/10W
		R454	0RJ1001D677	MCR03EZPJ102 1KOHM 5% 1/10W
		R458	0RJ1000D677	MCR03EZPJ101 100OHM 5% 1/10
		R460	0RJ0000D677	MCR03EZPJ000 0OHM 5% 1/10W
		R461	0RJ0000D677	MCR03EZPJ000 0OHM 5% 1/10W
		R462	0RJ2001D677	MCR03EZPJ202 2KOHM 5% 1/10W
		R481	0RJ4701D677	MCR03EZPJ472 4.7KOHM 5% 1/1
		R482	0RJ4701D677	MCR03EZPJ472 4.7KOHM 5% 1/1
		R494	0RJ0000D677	MCR03EZPJ000 0OHM 5% 1/10W
		R516	0RJ0000D677	MCR03EZPJ000 0OHM 5% 1/10W
		R517	0RJ0000D677	MCR03EZPJ000 0OHM 5% 1/10W
		R518	0RJ0000D677	MCR03EZPJ000 0OHM 5% 1/10W
		R520	0RJ1002D677	MCR03EZPJ103 10KOHM 5% 1/10
		R521	0RJ1002D677	MCR03EZPJ103 10KOHM 5% 1/10
		R524	0RJ0000D677	MCR03EZPJ000 0OHM 5% 1/10W
		R525	0RJ0000D677	MCR03EZPJ000 0OHM 5% 1/10W
		R526	0RJ0000D677	MCR03EZPJ000 0OHM 5% 1/10W
		R527	0RJ0000D677	MCR03EZPJ000 0OHM 5% 1/10W
		R536	0RJ0000D677	MCR03EZPJ000 0OHM 5% 1/10W
		R537	0RJ0000D677	MCR03EZPJ000 0OHM 5% 1/10W
		R600	0RJ0000D677	MCR03EZPJ000 0OHM 5% 1/10W
		R601	0RJ0000D677	MCR03EZPJ000 0OHM 5% 1/10W
		R602	0RJ1000D677	MCR03EZPJ101 100OHM 5% 1/10
		R603	0RJ1000D677	MCR03EZPJ101 100OHM 5% 1/10
		R607	0RJ0000D677	MCR03EZPJ000 0OHM 5% 1/10W
		R608	0RJ1000D677	MCR03EZPJ101 100OHM 5% 1/10

DATE: 2006. 04. 05.				
*S	*AL	LOC. NO.	PART NO.	DESCRIPTION / SPECIFICATION
		R609	0RJ1000D677	MCR03EZPJ101 100OHM 5% 1/10
		R619	0RJ4701D677	MCR03EZPJ472 4.7KOHM 5% 1/1
		R621	0RJ1001D677	MCR03EZPJ102 1KOHM 5% 1/10W
		R800	0RJ0000D677	MCR03EZPJ000 0OHM 5% 1/10W
		R810	0RJ0000D677	MCR03EZPJ000 0OHM 5% 1/10W
		R814	0RJ2701D677	MCR03EZPJ272 2.7KOHM 5% 1/1
		R818	0RJ2701D677	MCR03EZPJ272 2.7KOHM 5% 1/1
		R819	0RJ0000D677	MCR03EZPJ000 0OHM 5% 1/10W
		R821	0RJ3301D677	MCR03EZPJ332 3.3KOHM 5% 1/1
		R829	0RJ2001D677	MCR03EZPJ202 2KOHM 5% 1/10W
		R830	0RJ2001D677	MCR03EZPJ202 2KOHM 5% 1/10W
		R833	0RH0202D622	MCR10EZHJ200 20OHM 5% 1/8W
		R835	0RJ0562D677	MCR03EZPJ560 56OHM 5% 1/10W
		R836	0RJ0562D677	MCR03EZPJ560 56OHM 5% 1/10W
		R837	0RH0202D622	MCR10EZHJ200 20OHM 5% 1/8W
		R839	0RJ0562D677	MCR03EZPJ560 56OHM 5% 1/10W
		R840	0RJ0562D677	MCR03EZPJ560 56OHM 5% 1/10W
		R841	0RH0202D622	MCR10EZHJ200 20OHM 5% 1/8W
		R844	0RJ0562D677	MCR03EZPJ560 56OHM 5% 1/10W
		R845	0RH0202D622	MCR10EZHJ200 20OHM 5% 1/8W
		R846	0RH0202D622	MCR10EZHJ200 20OHM 5% 1/8W
		R847	0RH0202D622	MCR10EZHJ200 20OHM 5% 1/8W
		R849	0RJ0562D677	MCR03EZPJ560 56OHM 5% 1/10W
		R852	0RJ0222D677	MCR03EZPJ220 22OHM 5% 1/10W
		R853	0RJ0222D677	MCR03EZPJ220 22OHM 5% 1/10W
		R861	0RJ0222D677	MCR03EZPJ220 22OHM 5% 1/10W
		R862	0RJ0222D677	MCR03EZPJ220 22OHM 5% 1/10W
		R863	0RJ0222D677	MCR03EZPJ220 22OHM 5% 1/10W
		R864	0RJ0222D677	MCR03EZPJ220 22OHM 5% 1/10W
		R867	0RJ1002D677	MCR03EZPJ103 10KOHM 5% 1/10
		R868	0RJ1002D677	MCR03EZPJ103 10KOHM 5% 1/10
		R870	0RJ0222D677	MCR03EZPJ220 22OHM 5% 1/10W
		R871	0RJ0222D677	MCR03EZPJ220 22OHM 5% 1/10W
		R872	0RJ0222D677	MCR03EZPJ220 22OHM 5% 1/10W
		R873	0RJ0222D677	MCR03EZPJ220 22OHM 5% 1/10W
		R874	0RJ0222D677	MCR03EZPJ220 22OHM 5% 1/10W
		R878	0RJ0332D677	MCR03EZPJ330 33OHM 5% 1/10W
		R879	0RJ0332D677	MCR03EZPJ330 33OHM 5% 1/10W
		R880	0RJ0332D677	MCR03EZPJ330 33OHM 5% 1/10W
		R881	0RJ0332D677	MCR03EZPJ330 33OHM 5% 1/10W
		R882	0RJ0332D677	MCR03EZPJ330 33OHM 5% 1/10W
		R883	0RJ0332D677	MCR03EZPJ330 33OHM 5% 1/10W
		R884	0RJ0332D677	MCR03EZPJ330 33OHM 5% 1/10W
		R885	0RJ0332D677	MCR03EZPJ330 33OHM 5% 1/10W
		R889	0RJ1002D677	MCR03EZPJ103 10KOHM 5% 1/10
		R890	0RJ1002D677	MCR03EZPJ103 10KOHM 5% 1/10
		R891	0RJ1002D677	MCR03EZPJ103 10KOHM 5% 1/10
		R892	0RJ1002D677	MCR03EZPJ103 10KOHM 5% 1/10
		R893	0RJ1002D677	MCR03EZPJ103 10KOHM 5% 1/10
		R894	0RJ1002D677	MCR03EZPJ103 10KOHM 5% 1/10
		R905	0RJ0000D677	MCR03EZPJ000 0OHM 5% 1/10W
		R906	0RJ0000D677	MCR03EZPJ000 0OHM 5% 1/10W
		R907	0RJ0000D677	MCR03EZPJ000 0OHM 5% 1/10W
		R909	0RJ0222D677	MCR03EZPJ220 22OHM 5% 1/10W
		R910	0RJ0222D677	MCR03EZPJ220 22OHM 5% 1/10W
		R911	0RJ0000D677	MCR03EZPJ000 0OHM 5% 1/10W
		R912	0RJ0000D677	MCR03EZPJ000 0OHM 5% 1/10W
		R917	0RJ1002D677	MCR03EZPJ103 10KOHM 5% 1/10
		R918	0RJ1002D677	MCR03EZPJ103 10KOHM 5% 1/10
		R921	0RJ0222D677	MCR03EZPJ220 22OHM 5% 1/10W
		R922	0RJ0222D677	MCR03EZPJ220 22OHM 5% 1/10W
		R937	0RJ0222D677	MCR03EZPJ220 22OHM 5% 1/10W

DATE: 2006. 04. 05.				
*S	*AL	LOC. NO.	PART NO.	DESCRIPTION / SPECIFICATION
		R938	0RJ0222D677	MCR03EZPJ220 22OHM 5% 1/10W
		R940	0RJ0222D677	MCR03EZPJ220 22OHM 5% 1/10W
		L126	0RH0000D622	MCR10EZHJ000 0OHM 5% 1/8W 2
		L127	0RH0000D622	MCR10EZHJ000 0OHM 5% 1/8W 2
		L128	0RH0000D622	MCR10EZHJ000 0OHM 5% 1/8W 2
		L1852	0RJ0000D677	MCR03EZPJ000 0OHM 5% 1/10W
		L1854	0RJ0000D677	MCR03EZPJ000 0OHM 5% 1/10W
		L1855	0RJ0000D677	MCR03EZPJ000 0OHM 5% 1/10W
		L1857	0RJ0000D677	MCR03EZPJ000 0OHM 5% 1/10W
		L409	0RJ0000D677	MCR03EZPJ000 0OHM 5% 1/10W
		L410	0RJ0000D677	MCR03EZPJ000 0OHM 5% 1/10W
		L411	0RJ0000D677	MCR03EZPJ000 0OHM 5% 1/10W
		L412	0RJ0000D677	MCR03EZPJ000 0OHM 5% 1/10W
		R1001	0RJ1002D677	MCR03EZPJ103 10KOHM 5% 1/10
		R1008	0RJ1002D677	MCR03EZPJ103 10KOHM 5% 1/10
		R1013	0RJ4701D677	MCR03EZPJ472 4.7KOHM 5% 1/1
		R1102	0RJ1002D677	MCR03EZPJ103 10KOHM 5% 1/10
		R1103	0RJ1002D677	MCR03EZPJ103 10KOHM 5% 1/10
		R1104	0RJ2002D677	MCR03EZPJ202 2KOHM 5% 1/1
		R1213	0RJ0000D677	MCR03EZPJ000 0OHM 5% 1/10W
		R1236	0RJ1001D677	MCR03EZPJ102 1KOHM 5% 1/10W
		R1240	0RJ4702D677	MCR03EZPJ473 47KOHM 5% 1/10
		R1241	0RJ4702D677	MCR03EZPJ473 47KOHM 5% 1/10
		R1250	0RJ1000D677	MCR03EZPJ101 100OHM 5% 1/10
		R1252	0RJ1000D677	MCR03EZPJ101 100OHM 5% 1/10
		R1254	0RJ1000D677	MCR03EZPJ101 100OHM 5% 1/10
		R1255	0RJ1000D677	MCR03EZPJ101 100OHM 5% 1/10
		R1260	0RJ1002D677	MCR03EZPJ103 10KOHM 5% 1/10
		R1262	0RJ1002D677	MCR03EZPJ103 10KOHM 5% 1/10
		R1273	0RJ0000D677	MCR03EZPJ000 0OHM 5% 1/10W
		R1278	0RJ4701D677	MCR03EZPJ472 4.7KOHM 5% 1/1
		R1403	0RJ0221D677	MCR03EZPJ2R2 2.2OHM 5% 1/10
		R1404	0RJ0221D677	MCR03EZPJ2R2 2.2OHM 5% 1/10
		R1407	0RJ0221D677	MCR03EZPJ2R2 2.2OHM 5% 1/10
		R1409	0RJ0221D677	MCR03EZPJ2R2 2.2OHM 5% 1/10
		R1417	0RJ0331D677	MCR03EZPJ3R3 3.3OHM 5% 1/10
		R1423	0RJ0331D677	MCR03EZPJ3R3 3.3OHM 5% 1/10
		R1424	0RJ1002D677	MCR03EZPJ103 10KOHM 5% 1/10
		R1425	0RJ1002D677	MCR03EZPJ103 10KOHM 5% 1/10
		R1426	0RJ1002D677	MCR03EZPJ103 10KOHM 5% 1/10
		R1427	0RJ1002D677	MCR03EZPJ103 10KOHM 5% 1/10
		R1432	0RJ0101D677	MCR03EZPJ1R0 1OHM 5% 1/10W
		R1433	0RJ0101D677	MCR03EZPJ1R0 1OHM 5% 1/10W
		R1434	0RJ0101D677	MCR03EZPJ1R0 1OHM 5% 1/10W
		R1435	0RJ0101D677	MCR03EZPJ1R0 1OHM 5% 1/10W
		R1448	0RJ0000D677	MCR03EZPJ000 0OHM 5% 1/10W
		R1449	0RJ3301D677	MCR03EZPJ332 3.3KOHM 5% 1/1
		R1459	0RJ4701D677	MCR03EZPJ472 4.7KOHM 5% 1/1
		R1470	0RJ4701D677	MCR03EZPJ472 4.7KOHM 5% 1/1
		R168	0RJ0752D677	MCR03EZPJ750 75OHM 5% 1/10W
		R169	0RJ2203D677	MCR03EZPJ224 220KOHM 5% 1/1
		R170	0RJ0752D677	MCR03EZPJ750 75OHM 5% 1/10W
		R171	0RJ2203D677	MCR03EZPJ224 220KOHM 5% 1/1
		R172	0RJ0752D677	MCR03EZPJ750 75OHM 5% 1/10W
		R173	0RJ0752D677	MCR03EZPJ750 75OHM 5% 1/10W
		R180	0RJ2203D677	MCR03EZPJ224 220KOHM 5% 1/1
		R181	0RJ2203D677	MCR03EZPJ224 220KOHM 5% 1/1
		R182	0RJ0752D677	MCR03EZPJ750 75OHM 5% 1/10W
		R183	0RJ0752D677	MCR03EZPJ750 75OHM 5% 1/10W
		R1830	0RJ3301D677	MCR03EZPJ332 3.3KOHM 5% 1/1-CKD
		R1830	0RJ0000D677	MCR03EZPJ000 0OHM 5% 1/10W-SKD
		R1831	0RJ1001D677	MCR03EZPJ102 1KOHM 5% 1/10W-CKD

DATE: 2006. 04. 05.				
*S	*AL	LOC. NO.	PART NO.	DESCRIPTION / SPECIFICATION
		R184	0RJ0752D677	MCR03EZPJ750 75OHM 5% 1/10W
		R1842	0RJ0332D677	MCR03EZPJ330 33OHM 5% 1/10W
		R1843	0RJ0332D677	MCR03EZPJ330 33OHM 5% 1/10W
		R1844	0RJ0332D677	MCR03EZPJ330 33OHM 5% 1/10W
		R1845	0RJ0332D677	MCR03EZPJ330 33OHM 5% 1/10W
		R1846	0RJ0332D677	MCR03EZPJ330 33OHM 5% 1/10W
		R1847	0RJ0332D677	MCR03EZPJ330 33OHM 5% 1/10W
		R1848	0RJ0332D677	MCR03EZPJ330 33OHM 5% 1/10W
		R1849	0RJ0332D677	MCR03EZPJ330 33OHM 5% 1/10W
		R1850	0RJ0332D677	MCR03EZPJ330 33OHM 5% 1/10W
		R1851	0RJ0332D677	MCR03EZPJ330 33OHM 5% 1/10W
		R1852	0RJ0332D677	MCR03EZPJ330 33OHM 5% 1/10W
		R1853	0RJ0332D677	MCR03EZPJ330 33OHM 5% 1/10W
		R1854	0RJ0332D677	MCR03EZPJ330 33OHM 5% 1/10W
		R1855	0RJ0332D677	MCR03EZPJ330 33OHM 5% 1/10W
		R1856	0RJ0332D677	MCR03EZPJ330 33OHM 5% 1/10W
		R1857	0RJ0332D677	MCR03EZPJ330 33OHM 5% 1/10W
		R186	0RJ1002D677	MCR03EZPJ103 10KOHM 5% 1/10
		R1864	0RJ1002D677	MCR03EZPJ103 10KOHM 5% 1/10
		R1865	0RJ1002D677	MCR03EZPJ103 10KOHM 5% 1/10
		R1868	0RJ1002D677	MCR03EZPJ103 10KOHM 5% 1/10
		R1869	0RJ1002D677	MCR03EZPJ103 10KOHM 5% 1/10
		R1870	0RJ1002D677	MCR03EZPJ103 10KOHM 5% 1/10
		R1873	0RJ1002D677	MCR03EZPJ103 10KOHM 5% 1/10
		R1874	0RJ1002D677	MCR03EZPJ103 10KOHM 5% 1/10
		R1875	0RJ1002D677	MCR03EZPJ103 10KOHM 5% 1/10
		R1878	0RJ1201D677	MCR03EZPJ122 1.2KOHM 5% 1/1
		R1879	0RJ0512D677	MCR03EZPJ510 51OHM 5% 1/10W
		R188	0RJ1001D677	MCR03EZPJ102 1KOHM 5% 1/10W
		R1880	0RJ0222D677	MCR03EZPJ220 22OHM 5% 1/10W
		R1881	0RJ1001D677	MCR03EZPJ102 1KOHM 5% 1/10W
		R189	0RJ1001D677	MCR03EZPJ102 1KOHM 5% 1/10W
		R198	0RJ0822D677	MCR03EZPJ820 82OHM 5% 1/10W
		R199	0RJ0822D677	MCR03EZPJ820 82OHM 5% 1/10W
		R208	0RJ1002D677	MCR03EZPJ103 10KOHM 5% 1/10
		R209	0RJ2201D677	MCR03EZPJ222 2.2KOHM 5% 1/1
		R210	0RJ1002D677	MCR03EZPJ103 10KOHM 5% 1/10
		R2100	0RJ1002D677	MCR03EZPJ103 10KOHM 5% 1/10
		R2101	0RJ0000D677	MCR03EZPJ000 0OHM 5% 1/10W
		R2102	0RJ1002D677	MCR03EZPJ103 10KOHM 5% 1/10
		R2105	0RJ4703D677	MCR03EZPJ474 470KOHM 5% 1/1
		R2106	0RJ4703D677	MCR03EZPJ474 470KOHM 5% 1/1
		R2108	0RJ2203D677	MCR03EZPJ224 220KOHM 5% 1/1
		R2109	0RJ2203D677	MCR03EZPJ224 220KOHM 5% 1/1
		R211	0RJ0222D677	MCR03EZPJ220 22OHM 5% 1/10W
		R2112	0RJ1002D677	MCR03EZPJ103 10KOHM 5% 1/10
		R2113	0RJ1001D677	MCR03EZPJ102 1KOHM 5% 1/10W
		R2114	0RJ1001D677	MCR03EZPJ102 1KOHM 5% 1/10W
		R2115	0RJ2001D677	MCR03EZPJ202 2KOHM 5% 1/10W
		R2116	0RJ2001D677	MCR03EZPJ202 2KOHM 5% 1/10W
		R212	0RJ0102D677	MCR03EZPJ100 10OHM 5% 1/10W
		R213	0RJ1001D677	MCR03EZPJ102 1KOHM 5% 1/10W
		R214	0RJ0000D677	MCR03EZPJ000 0OHM 5% 1/10W
		R215	0RJ3300D677	MCR03EZPJ331 330OHM 5% 1/10
		R216	0RJ3300D677	MCR03EZPJ331 330OHM 5% 1/10
		R217	0RJ4701D677	MCR03EZPJ472 4.7KOHM 5% 1/1
		R218	0RJ4700D677	MCR03EZPJ471 470OHM 5% 1/10
		R219	0RJ0822D677	MCR03EZPJ820 82OHM 5% 1/10W
		R220	0RJ0000D677	MCR03EZPJ000 0OHM 5% 1/10W
		R221	0RJ0000D677	MCR03EZPJ000 0OHM 5% 1/10W
		R222	0RJ1000D677	MCR03EZPJ101 100OHM 5% 1/10
		R223	0RJ1001D677	MCR03EZPJ102 1KOHM 5% 1/10W

DATE: 2006. 04. 05.				
*S	*AL	LOC. NO.	PART NO.	DESCRIPTION / SPECIFICATION
		R224	0RJ4701D677	MCR03EZPJ472 4.7KOHM 5% 1/1
		R225	0RJ2000D677	MCR03EZPJ201 200OHM 5% 1/10
		R227	0RJ2700D677	MCR03EZPJ271 270OHM 5% 1/10
		R228	0RJ2200D677	MCR03EZPJ221 220OHM 5% 1/10
		R229	0RJ1001D677	MCR03EZPJ102 1KOHM 5% 1/10W
		R230	0RJ1800D677	MCR03EZPJ181 180OHM 5% 1/10
		R231	0RJ1500D677	MCR03EZPJ151 150OHM 5% 1/10
		R232	0RJ0000D677	MCR03EZPJ000 0OHM 5% 1/10W
		R233	0RJ0000D677	MCR03EZPJ000 0OHM 5% 1/10W
		R239	0RJ2201D677	MCR03EZPJ222 2.2KOHM 5% 1/1
		R245	0RJ0000D677	MCR03EZPJ000 0OHM 5% 1/10W
		R248	0RJ0000D677	MCR03EZPJ000 0OHM 5% 1/10W
		R2811	0RJ4701D677	MCR03EZPJ472 4.7KOHM 5% 1/1
		R2812	0RJ4701D677	MCR03EZPJ472 4.7KOHM 5% 1/1
		R305	0RJ3300D677	MCR03EZPJ331 330OHM 5% 1/10
		R309	0RJ1000D677	MCR03EZPJ101 100OHM 5% 1/10
		R310	0RJ1000D677	MCR03EZPJ101 100OHM 5% 1/10
		R327	0RJ2200D677	MCR03EZPJ221 220OHM 5% 1/10
		R328	0RJ2200D677	MCR03EZPJ221 220OHM 5% 1/10
		R363	0RJ2200D677	MCR03EZPJ221 220OHM 5% 1/10
		R364	0RJ2200D677	MCR03EZPJ221 220OHM 5% 1/10
		R365	0RJ1503D677	MCR03EZPJ154 150KOHM 5% 1/1
		R366	0RJ0752D677	MCR03EZPJ750 75OHM 5% 1/10W
		R367	0RJ0752D677	MCR03EZPJ750 75OHM 5% 1/10W
		R368	0RJ0752D677	MCR03EZPJ750 75OHM 5% 1/10W
		R369	0RJ4703D677	MCR03EZPJ474 470KOHM 5% 1/1
		R370	0RJ4703D677	MCR03EZPJ474 470KOHM 5% 1/1
		R375	0RJ0000D677	MCR03EZPJ000 0OHM 5% 1/10W
		R406	0RJ0432D677	MCR03EZPJ430 43OHM 5% 1/10W
		R409	0RJ0432D677	MCR03EZPJ430 43OHM 5% 1/10W
		R455	0RJ4701D677	MCR03EZPJ472 4.7KOHM 5% 1/1
		R456	0RJ4701D677	MCR03EZPJ472 4.7KOHM 5% 1/1
		R457	0RJ4701D677	MCR03EZPJ472 4.7KOHM 5% 1/1
		R459	0RJ4701D677	MCR03EZPJ472 4.7KOHM 5% 1/1
		R463	0RJ4703D677	MCR03EZPJ474 470KOHM 5% 1/1
		R464	0RJ2001D677	MCR03EZPJ202 2KOHM 5% 1/10W
		R465	0RJ1501D677	MCR03EZPJ152 1.5KOHM 5% 1/1
		R466	0RJ4703D677	MCR03EZPJ474 470KOHM 5% 1/1
		R467	0RJ1501D677	MCR03EZPJ152 1.5KOHM 5% 1/1
		R469	0RJ0000D677	MCR03EZPJ000 0OHM 5% 1/10W
		R474	0RJ2001D677	MCR03EZPJ202 2KOHM 5% 1/10W
		R475	0RJ2001D677	MCR03EZPJ202 2KOHM 5% 1/10W
		R476	0RJ4703D677	MCR03EZPJ474 470KOHM 5% 1/1
		R477	0RJ4703D677	MCR03EZPJ474 470KOHM 5% 1/1
		R478	0RJ0000D677	MCR03EZPJ000 0OHM 5% 1/10W
		R479	0RJ0000D677	MCR03EZPJ000 0OHM 5% 1/10W
		R484	0RJ0000D677	MCR03EZPJ000 0OHM 5% 1/10W
		R486	0RJ0000D677	MCR03EZPJ000 0OHM 5% 1/10W
		R492	0RJ2001D677	MCR03EZPJ202 2KOHM 5% 1/10W
		R493	0RJ2001D677	MCR03EZPJ202 2KOHM 5% 1/10W
		R500	0RJ2203D677	MCR03EZPJ224 220KOHM 5% 1/1
		R501	0RJ2203D677	MCR03EZPJ224 220KOHM 5% 1/1
		R502	0RJ1001D677	MCR03EZPJ102 1KOHM 5% 1/10W
		R503	0RJ1001D677	MCR03EZPJ102 1KOHM 5% 1/10W
		R504	0RJ0752D677	MCR03EZPJ750 75OHM 5% 1/10W
		R505	0RJ0752D677	MCR03EZPJ750 75OHM 5% 1/10W
		R506	0RJ0752D677	MCR03EZPJ750 75OHM 5% 1/10W
		R507	0RJ4701D677	MCR03EZPJ472 4.7KOHM 5% 1/1
		R508	0RJ4701D677	MCR03EZPJ472 4.7KOHM 5% 1/1
		R509	0RJ0000D677	MCR03EZPJ000 0OHM 5% 1/10W
		R510	0RJ0000D677	MCR03EZPJ000 0OHM 5% 1/10W
		R511	0RJ0000D677	MCR03EZPJ000 0OHM 5% 1/10W

DATE: 2006. 04. 05.				
*S	*AL	LOC. NO.	PART NO.	DESCRIPTION / SPECIFICATION
		R512	0RJ0000D677	MCR03EZPJ000 0OHM 5% 1/10W
		R513	0RJ1001D677	MCR03EZPJ102 1KOHM 5% 1/10W
		R514	0RJ0000D677	MCR03EZPJ000 0OHM 5% 1/10W
		R515	0RJ1001D677	MCR03EZPJ102 1KOHM 5% 1/10W
		R519	0RJ1001D677	MCR03EZPJ102 1KOHM 5% 1/10W
		R522	0RJ1000D677	MCR03EZPJ101 100OHM 5% 1/10
		R523	0RJ1000D677	MCR03EZPJ101 100OHM 5% 1/10
		R531	0RJ0000D677	MCR03EZPJ000 0OHM 5% 1/10W
		R532	0RJ0000D677	MCR03EZPJ000 0OHM 5% 1/10W
		R533	0RJ0000D677	MCR03EZPJ000 0OHM 5% 1/10W
		R534	0RJ4701D677	MCR03EZPJ472 4.7KOHM 5% 1/1
		R540	0RJ0000D677	MCR03EZPJ000 0OHM 5% 1/10W
		R541	0RJ0000D677	MCR03EZPJ000 0OHM 5% 1/10W
		R542	0RJ4700D677	MCR03EZPJ471 470OHM 5% 1/10
		R544	0RJ0000D677	MCR03EZPJ000 0OHM 5% 1/10W-SKD
		R604	0RJ4701D677	MCR03EZPJ472 4.7KOHM 5% 1/1
		R605	0RJ4700D677	MCR03EZPJ471 470OHM 5% 1/10
		R606	0RJ0000D677	MCR03EZPJ000 0OHM 5% 1/10W
		R809	0RJ1000D677	MCR03EZPJ101 100OHM 5% 1/10
		R834	0RH0202D622	MCR10EZHJ200 20OHM 5% 1/8W
		R838	0RH0202D622	MCR10EZHJ200 20OHM 5% 1/8W
		R842	0RH0202D622	MCR10EZHJ200 20OHM 5% 1/8W
		R851	0RJ0000D677	MCR03EZPJ000 0OHM 5% 1/10W
		R854	0RJ0000D677	MCR03EZPJ000 0OHM 5% 1/10W
		R855	0RJ0000D677	MCR03EZPJ000 0OHM 5% 1/10W
		R857	0RJ0000D677	MCR03EZPJ000 0OHM 5% 1/10W
		R859	0RJ0222D677	MCR03EZPJ220 22OHM 5% 1/10W
		R860	0RJ0222D677	MCR03EZPJ220 22OHM 5% 1/10W
		R865	0RJ0000D677	MCR03EZPJ000 0OHM 5% 1/10W
		R866	0RJ0222D677	MCR03EZPJ220 22OHM 5% 1/10W
		R875	0RJ0000D677	MCR03EZPJ000 0OHM 5% 1/10W
		R876	0RJ0000D677	MCR03EZPJ000 0OHM 5% 1/10W
		R877	0RJ0332D677	MCR03EZPJ330 33OHM 5% 1/10W
		R886	0RJ0332D677	MCR03EZPJ330 33OHM 5% 1/10W
		R887	0RJ0332D677	MCR03EZPJ330 33OHM 5% 1/10W
		R888	0RJ0332D677	MCR03EZPJ330 33OHM 5% 1/10W
		R900	0RJ1002D677	MCR03EZPJ103 10KOHM 5% 1/10
		R904	0RJ0000D677	MCR03EZPJ000 0OHM 5% 1/10W
		R908	0RJ0222D677	MCR03EZPJ220 22OHM 5% 1/10W
		R914	0RJ0000D677	MCR03EZPJ000 0OHM 5% 1/10W
		R915	0RJ0000D677	MCR03EZPJ000 0OHM 5% 1/10W
		R919	0RJ2700D677	MCR03EZPJ271 270OHM 5% 1/10
		R920	0RJ2700D677	MCR03EZPJ271 270OHM 5% 1/10
		R923	0RJ1200D677	MCR03EZPJ121 120OHM 5% 1/10
		R924	0RJ1200D677	MCR03EZPJ121 120OHM 5% 1/10
		R934	0RJ1002D677	MCR03EZPJ103 10KOHM 5% 1/10
		R824	0RH0202D622	MCR10EZHJ200 20OHM 5% 1/8W
		R826	0RH0202D622	MCR10EZHJ200 20OHM 5% 1/8W
		R828	0RH0202D622	MCR10EZHJ200 20OHM 5% 1/8W
		L129	0RH0000D622	MCR10EZHJ000 0OHM 5% 1/8W 2
		L130	0RH0000D622	MCR10EZHJ000 0OHM 5% 1/8W 2
		L131	0RH0000D622	MCR10EZHJ000 0OHM 5% 1/8W 2
		R175	0RJ2203D677	MCR03EZPJ224 220KOHM 5% 1/1
		R176	0RJ2203D677	MCR03EZPJ224 220KOHM 5% 1/1
		R177	0RJ0752D677	MCR03EZPJ750 75OHM 5% 1/10W
		R178	0RJ0752D677	MCR03EZPJ750 75OHM 5% 1/10W
		R179	0RJ0752D677	MCR03EZPJ750 75OHM 5% 1/10W
		R193	0RJ1001D677	MCR03EZPJ102 1KOHM 5% 1/10W
		R194	0RJ1001D677	MCR03EZPJ102 1KOHM 5% 1/10W
		R2107	0RJ1002D677	MCR03EZPJ103 10KOHM 5% 1/10
		R2803	0RJ1002D677	MCR03EZPJ103 10KOHM 5% 1/10
		R1810	0RJ4701D677	MCR03EZPJ472 4.7KOHM 5% 1/1-42LC2R

DATE: 2006. 04. 05.				
*S	*AL	LOC. NO.	PART NO.	DESCRIPTION / SPECIFICATION
		L1819	0RJ0000D677	MCR03EZPJ000 0OHM 5% 1/10W
		L1820	0RJ0000D677	MCR03EZPJ000 0OHM 5% 1/10W
		L1821	0RJ0000D677	MCR03EZPJ000 0OHM 5% 1/10W
		L1822	0RJ0000D677	MCR03EZPJ000 0OHM 5% 1/10W
		L1823	0RJ0000D677	MCR03EZPJ000 0OHM 5% 1/10W
		R1828	0RJ0000D677	MCR03EZPJ000 0OHM 5% 1/10W-42LC2R
		R2800	0RJ4701D677	MCR03EZPJ472 4.7KOHM 5% 1/1
		R2801	0RJ4701D677	MCR03EZPJ472 4.7KOHM 5% 1/1
		R2802	0RJ0000D677	MCR03EZPJ000 0OHM 5% 1/10W
		R820	0RJ4701D677	MCR03EZPJ472 4.7KOHM 5% 1/1
		R822	0RJ4701D677	MCR03EZPJ472 4.7KOHM 5% 1/1
		R1022	0RJ1001D677	MCR03EZPJ102 1KOHM 5% 1/10W
		R1023	0RJ1002D677	MCR03EZPJ103 10KOHM 5% 1/10
		R1829	0RJ0000D677	MCR03EZPJ000 0OHM 5% 1/10W
		R1007	0RJ1002D677	MCR03EZPJ103 10KOHM 5% 1/10-37LC2R
		R1007	0RJ4701D677	MCR03EZPJ472 4.7KOHM 5% 1/1-42LC2R
		R1895	0RJ0000D677	MCR03EZPJ000 0OHM 5% 1/10W-37LC2R
		R1896	0RJ0000D677	MCR03EZPJ000 0OHM 5% 1/10W-42LC2R
		R1897	0RJ0000D677	MCR03EZPJ000 0OHM 5% 1/10W-42LC2R
		R856	0RJ1501D677	MCR03EZPJ152 1.5KOHM 5% 1/1-37LC2R
		R856	0RJ4701D677	MCR03EZPJ472 4.7KOHM 5% 1/1-42LC2R
		R858	0RJ0000D677	MCR03EZPJ000 0OHM 5% 1/10W-42LC2R
		R858	0RJ1501D677	MCR03EZPJ152 1.5KOHM 5% 1/1-37LC2R
		R246	0RJ1002D677	MCR03EZPJ103 10KOHM 5% 1/10
		R200	0RJ0822D677	MCR03EZPJ820 82OHM 5% 1/10W
		R201	0RJ4700D677	MCR03EZPJ471 470OHM 5% 1/10
		R202	0RJ4700D677	MCR03EZPJ471 470OHM 5% 1/10
		R203	0RJ3900D677	MCR03EZPJ391 390OHM 5% 1/10
		R204	0RJ0000D677	MCR03EZPJ000 0OHM 5% 1/10W
		R205	0RJ2201D677	MCR03EZPJ222 2.2KOHM 5% 1/1
		R206	0RJ3300D677	MCR03EZPJ331 330OHM 5% 1/10
		R207	0RJ3300D677	MCR03EZPJ331 330OHM 5% 1/10
		<b>OTHERS</b>		
		D1003	0DL233309AC	SAM2333 RED/Y-GREEN 2.7V 2.
		D1103	0DL233309AC	SAM2333 RED/Y-GREEN 2.7V 2.
		X400	156-A02M	HC-49/U 18.432MHZ 30PPM 18.
		X1200	6202TST001H	SX-1 27MHZ 30PPM 27MHZ 30PP
		X800	6212AB2015J	HC-49SM 19.66080HZ 19.6608H
		X300	166-E02F	CSBLA500KECF09-B0 500KHZ 2
		SW800	6600VR1004A	SKHMPWE010 1C1P 12VDC 0.05A
		SW900	6600VR1004A	SKHMPWE010 1C1P 12VDC 0.05A
		TU200	6700MF0017B	TAFV-W302P PAL - - - - HORI
		TU201	6700MF0017A	TAUV-W301P PAL - - - - HORI
		<b>CONTROL BOARD</b>		
		SW101	140-313A	THVV501BBC 1C1P 12VDC 0.05A
		SW102	140-313A	THVV501BBC 1C1P 12VDC 0.05A
		SW103	140-313A	THVV501BBC 1C1P 12VDC 0.05A
		SW104	140-313A	THVV501BBC 1C1P 12VDC 0.05A
		SW105	140-313A	THVV501BBC 1C1P 12VDC 0.05A
		SW106	140-313A	THVV501BBC 1C1P 12VDC 0.05A
		SW107	140-313A	THVV501BBC 1C1P 12VDC 0.05A
		SW108	140-313A	THVV501BBC 1C1P 12VDC 0.05A
		R101	0RH1302D622	MCR10EZHJ133 13KOHM 5% 1/8W
		R102	0RH4701D622	MCR10EZHJ472 4.7KOHM 5% 1/8
		R103	0RH1501D622	MCR10EZHJ152 1.5KOHM 5% 1/8
		R104	0RH0000D622	MCR10EZHJ000 0OHM 5% 1/8W 2
		R105	0RH1302D622	MCR10EZHJ133 13KOHM 5% 1/8W
		R106	0RH4701D622	MCR10EZHJ472 4.7KOHM 5% 1/8

DATE: 2006. 04. 05.

*S	*AL	LOC. NO.	PART NO.	DESCRIPTION / SPECIFICATION
		R107	0RH1501D622	MCR10EZJ152 1.5KOHM 5% 1/8
		R108	0RH0000D622	MCR10EZJ000 0OHM 5% 1/8W 2
<b>PREAMP&amp;LED BOARD</b>				
		C200	0CH5101K416	C2012C0G1H101JT 100pF 5% 50
		C201	0CH5330K416	C2012C0G1H330JT 33pF 5% 50V
		C202	0CE476VF6DC	VG476M016S0ANE010 47uF 20%
		C203	0CE476VF6DC	VG476M016S0ANE010 47uF 20%
		C204	0CE476VF6DC	VG476M016S0ANE010 47uF 20%
		L200	0LC1032101A	FI-C3216-103KJT 10UH 10% -
		Q200	0TR387500AA	2SC3875S(ALY) NPN 5V 60V 50
		Q201	0TR387500AA	2SC3875S(ALY) NPN 5V 60V 50
		Q202	0TR387500AA	2SC3875S(ALY) NPN 5V 60V 50
		R200	0RH0000D622	MCR10EZJ000 0OHM 5% 1/8W 2
		R201	0RH0000D622	MCR10EZJ000 0OHM 5% 1/8W 2
		R202	0RH4700D622	MCR10EZJ471 470OHM 5% 1/8W
		R203	0RH0000D622	MCR10EZJ000 0OHM 5% 1/8W 2
		R204	0RH4700D622	MCR10EZJ471 470OHM 5% 1/8W
		R205	0RH0000D622	MCR10EZJ000 0OHM 5% 1/8W 2
		R206	0RH0000D622	MCR10EZJ000 0OHM 5% 1/8W 2
		R207	0RJ1001D677	MCR03EZPJ02 1KOHM 5% 1/10W
		R208	0RH4700D622	MCR10EZJ471 470OHM 5% 1/8W
		D200	0DLAU0410AA	SAW5670 ROUND 5mM AMBER/WHI
		IC201	6712000013A	TSOP4438SO1 4.5TO5.5V 1.5MA
<b>SIDE A/V BOARD</b>				
		C101	0CH5101K416	C2012C0G1H101JT 100pF 5% 50
		C102	0CH5101K416	C2012C0G1H101JT 100pF 5% 50
		R102	0RH0000D622	MCR10EZJ000 0OHM 5% 1/8W 2
		R103	0RH0000D622	MCR10EZJ000 0OHM 5% 1/8W 2
		R104	0RH0000D622	MCR10EZJ000 0OHM 5% 1/8W 2
		R105	0RH4700D622	MCR10EZJ471 470OHM 5% 1/8W
		R106	0RH4700D622	MCR10EZJ471 470OHM 5% 1/8W

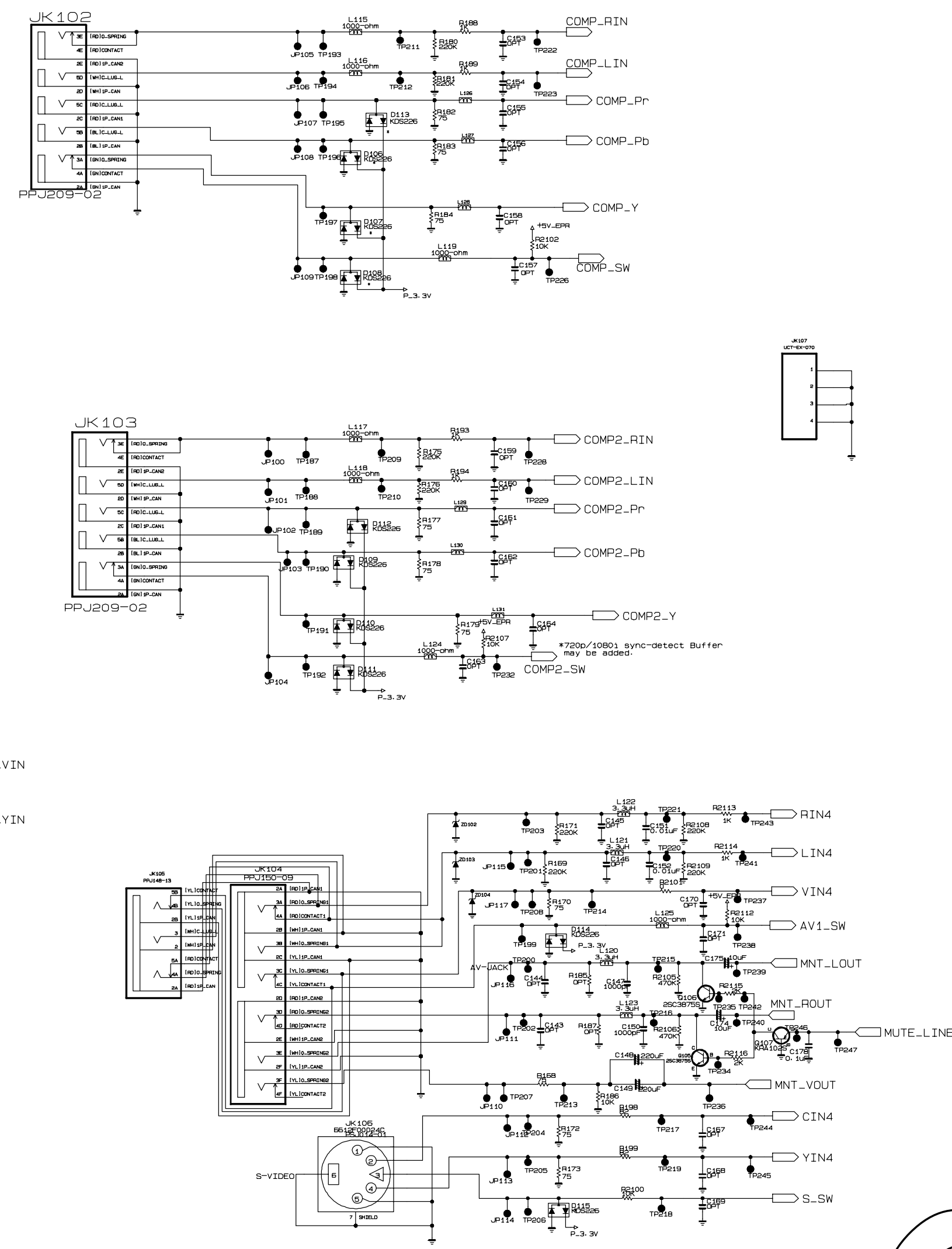
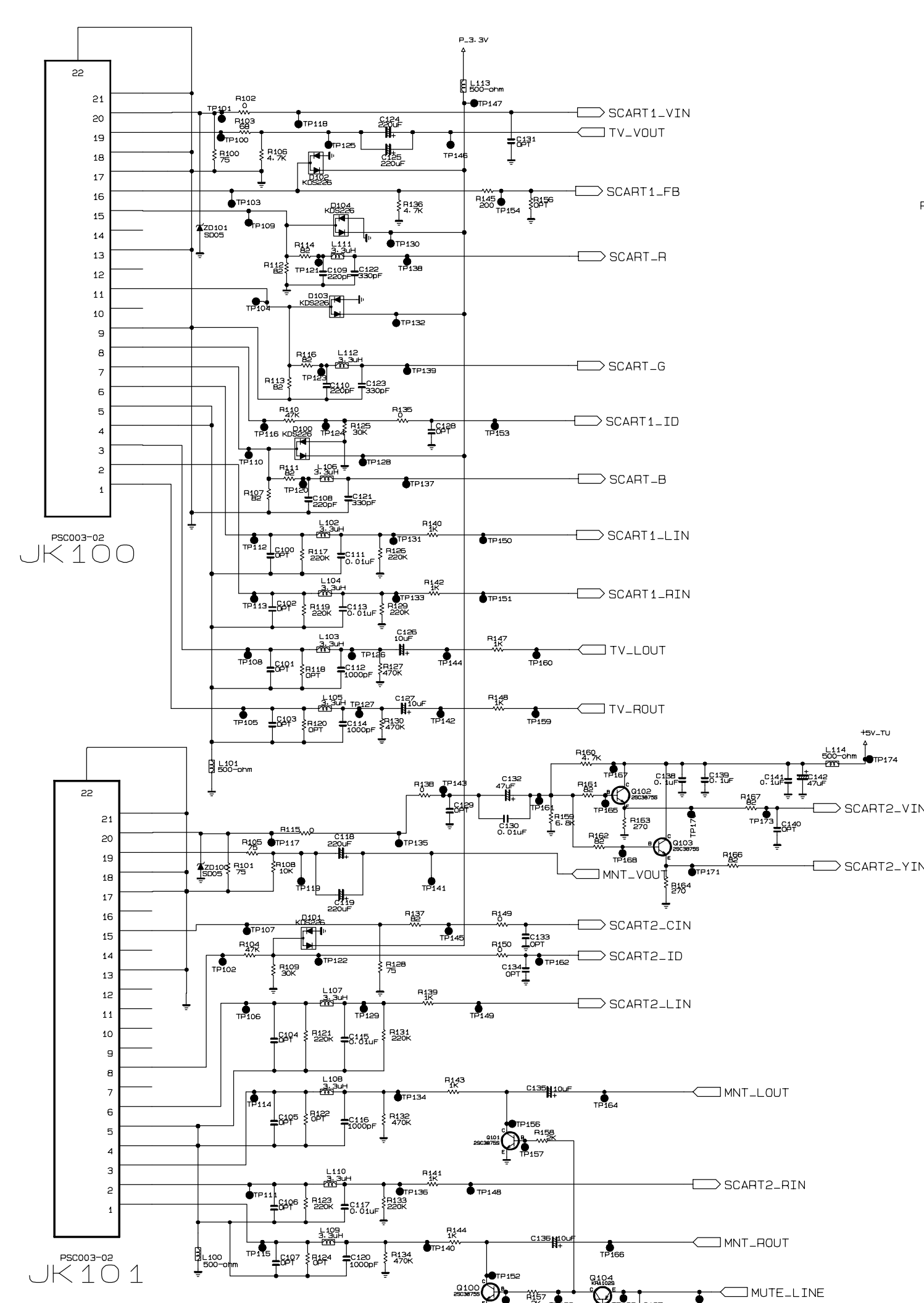

THE SYMBOL MARK OF THIS SCHEMATIC DIAGRAM INCORPORATES SPECIAL FEATURES IMPORTANT FOR PROTECTION FROM X-RADIATION, FILTRATION AND ELECTRICAL SHOCK HAZARDS. WHEN SERVICING IT IS ESSENTIAL THAT ONLY MANUFACTURER SPECIFIED PARTS BE USED FOR THE CRITICAL COMPONENTS IN THE MARK OF THE SCHEMATIC.

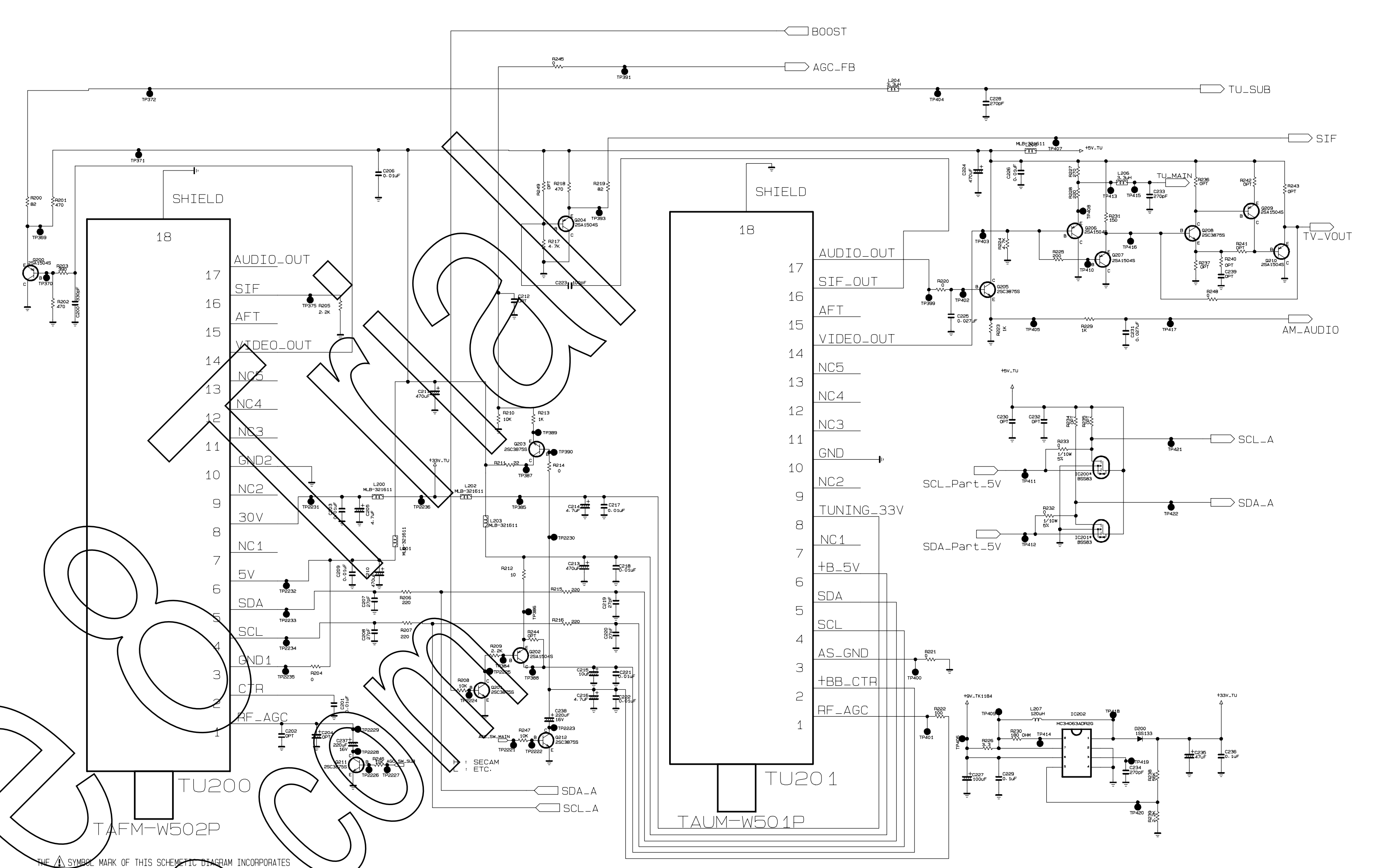

THE SYMBOL MARK OF THIS SCHEMATIC DIAGRAM INCORPORATES SPECIAL FEATURES IMPORTANT FOR PROTECTION FROM X-RADIATION, FILTRATION AND ELECTRICAL SHOCK HAZARDS. WHEN SERVICING IT IS ESSENTIAL THAT ONLY MANUFACTURER SPECIFIED PARTS BE USED FOR THE CRITICAL COMPONENTS IN THE MARK OF THE SCHEMATIC.

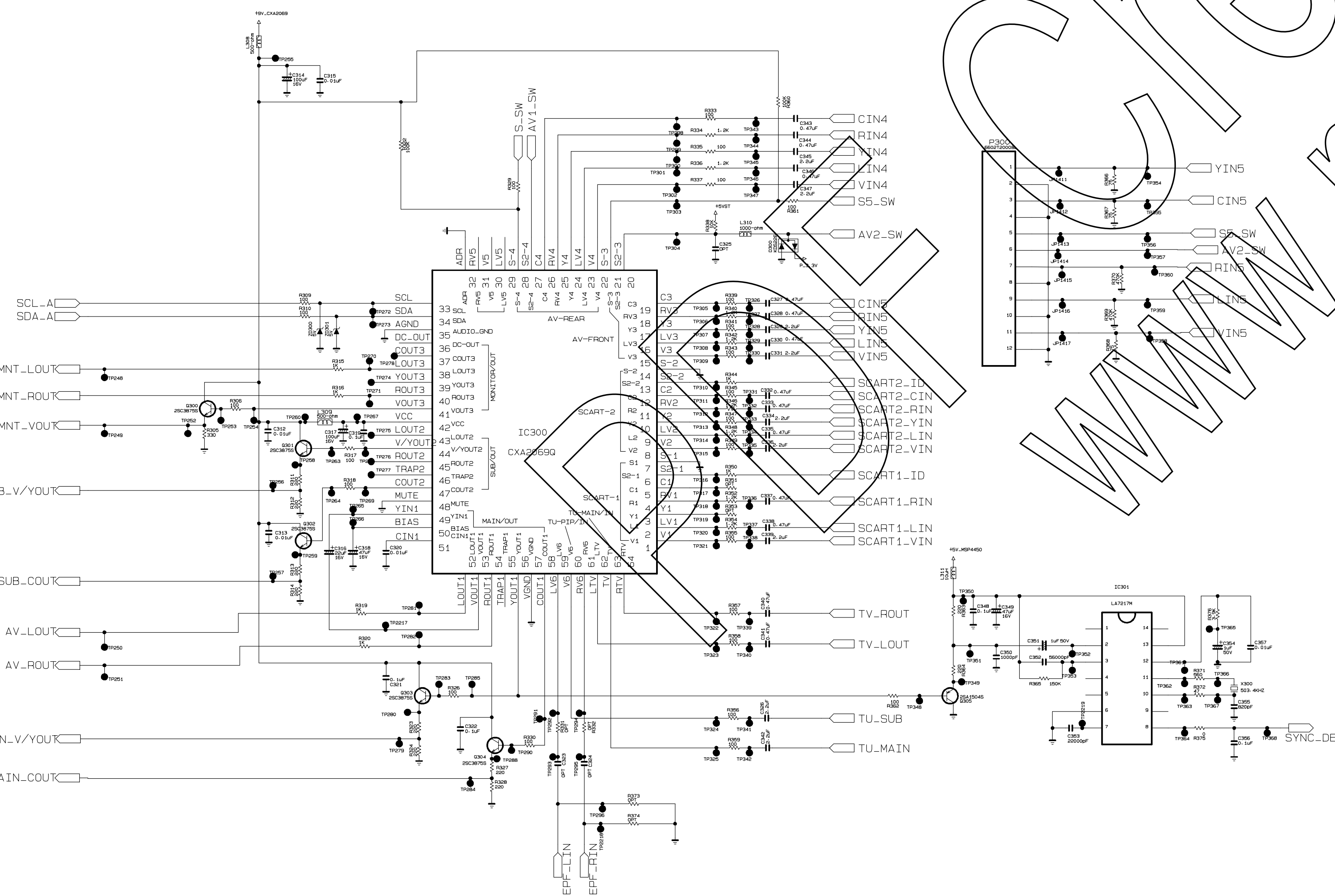

THE SYMBOL MARK OF THIS SCHEMATIC DIAGRAM INCORPORATES SPECIAL FEATURES IMPORTANT FOR PROTECTION FROM X-RADIATION, FILTRATION AND ELECTRICAL SHOCK HAZARDS. WHEN SERVICING IT IS ESSENTIAL THAT ONLY MANUFACTURER SPECIFIED PARTS BE USED FOR THE CRITICAL COMPONENTS IN THE MARK OF THE SCHEMATIC.

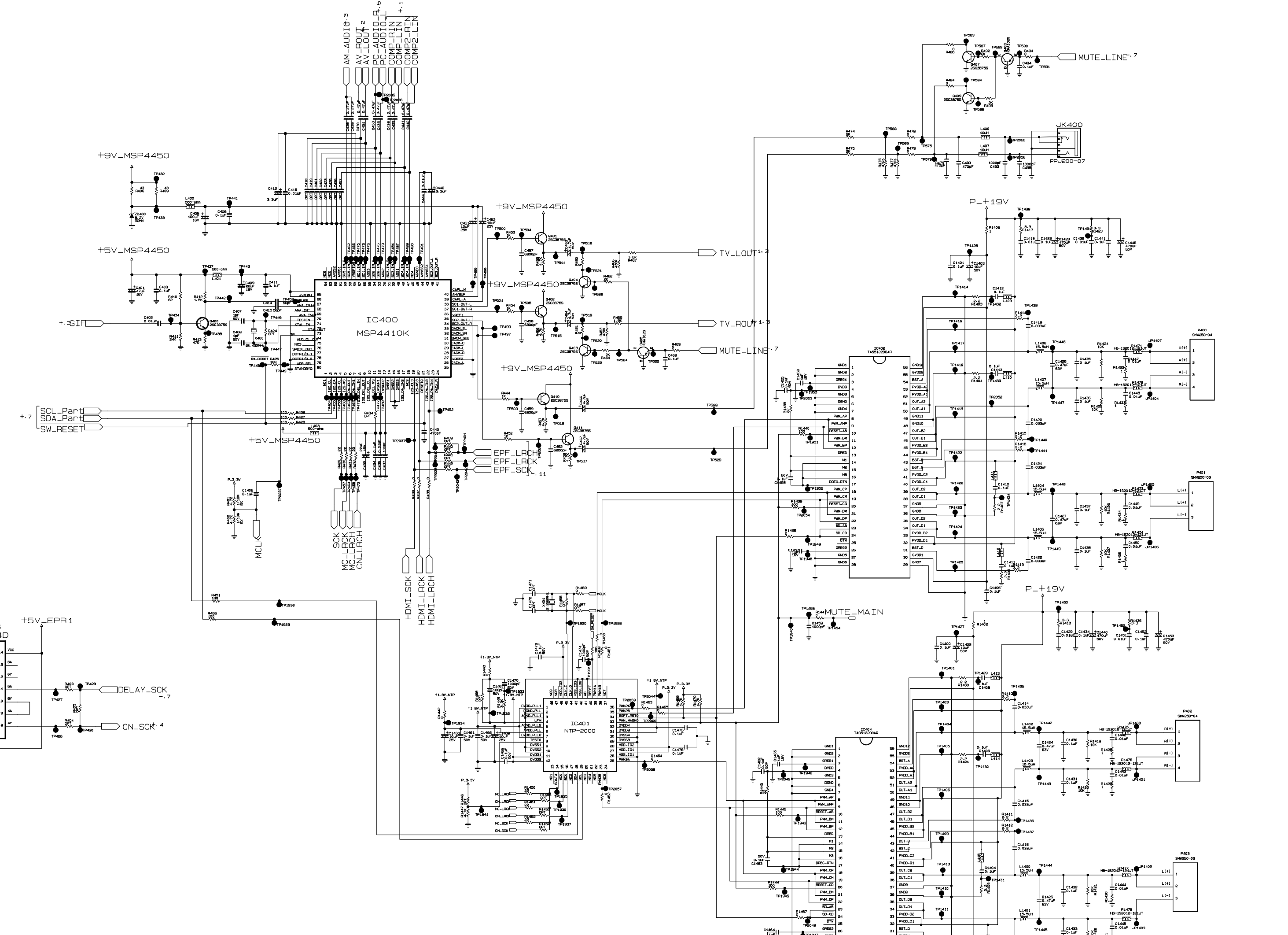

THE SYMBOL MARK OF THIS SCHEMATIC DIAGRAM INCORPORATES SPECIAL FEATURES IMPORTANT FOR PROTECTION FROM X-RADIATION, FILTRATION AND ELECTRICAL SHOCK HAZARDS. WHEN SERVICING IT IS ESSENTIAL THAT ONLY MANUFACTURER SPECIFIED PARTS BE USED FOR THE CRITICAL COMPONENTS IN THE MARK OF THE SCHEMATIC.





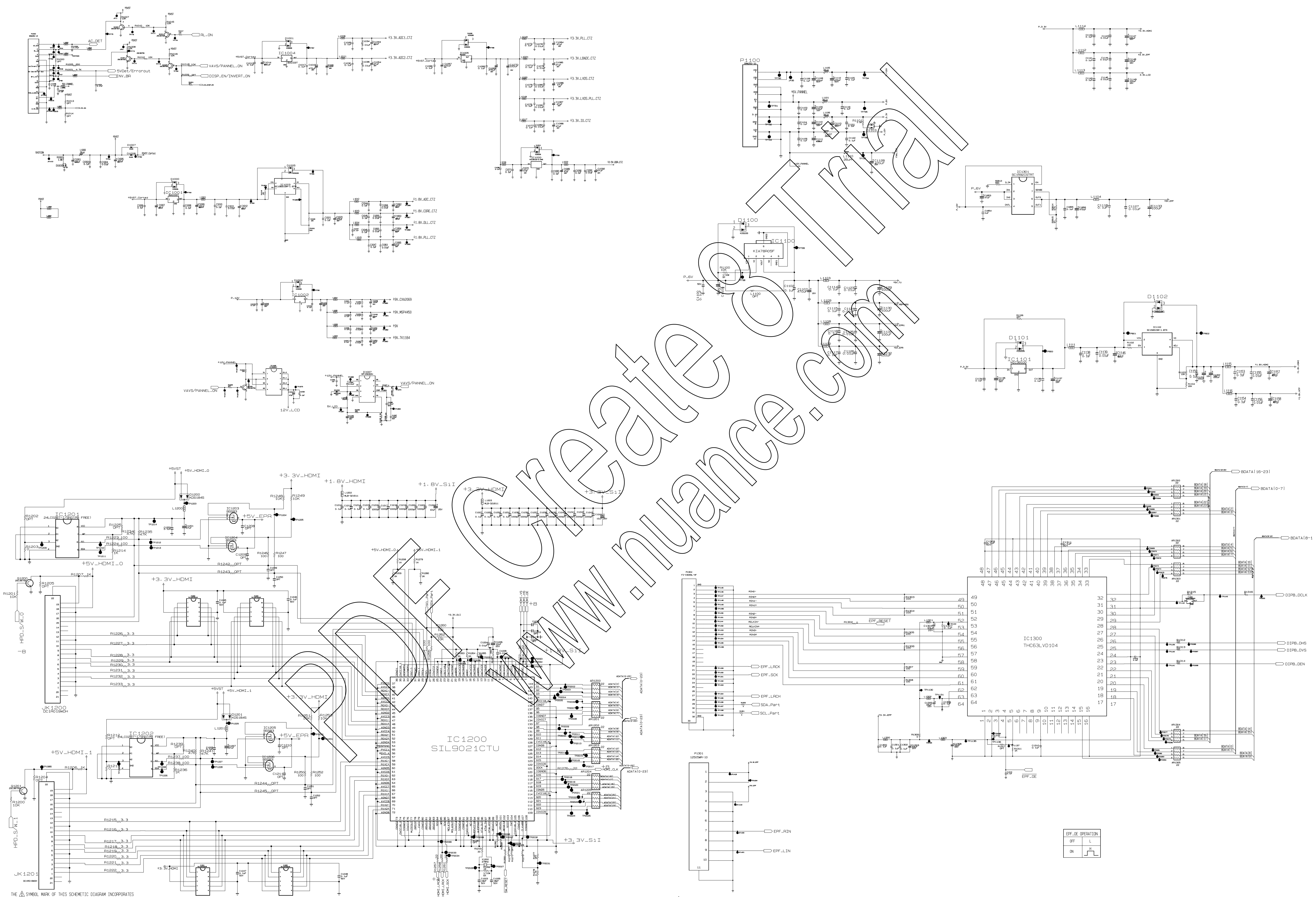

THE SYMBOL MARK OF THIS SCHEMATIC DIAGRAM INCORPORATES SPECIAL FEATURES IMPORTANT FOR PROTECTION FROM X-RADIATION. PLEASE AND ELECTRICAL CHECK MANUALLY WHEN SERVICING IT IS ESSENTIAL THAT ONLY MANUFACTURER SPECIFIED PARTS BE USED FOR THE CRITICAL COMPONENTS IN THE SYMBOL MARK OF THE SCHEMATIC.

THE SYMBOL MARK OF THIS SCHEMATIC DIAGRAM INCORPORATES SPECIAL FEATURES IMPORTANT FOR PROTECTION FROM X-RADIATION. PLEASE AND ELECTRICAL CHECK MANUALLY WHEN SERVICING IT IS ESSENTIAL THAT ONLY MANUFACTURER SPECIFIED PARTS BE USED FOR THE CRITICAL COMPONENTS IN THE SYMBOL MARK OF THE SCHEMATIC.

EPF_OE OPERATION	
OFF	L
ON	H





**LG Electronics Inc.**

P/NO : MFL30105507

Mar., 2006  
Printed in Korea