



Internal Use Only

website:<http://biz.LGservice.com>

LCD TV

SERVICE MANUAL

CHASSIS : LB81C

MODEL : 42LG61YD 42LG61YD-AC

CAUTION

BEFORE SERVICING THE CHASSIS,
READ THE SAFETY PRECAUTIONS IN THIS MANUAL.

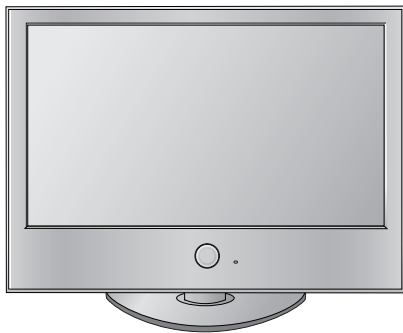

CONTENTS

CONTENTS	2
PRODUCT SAFETY	3
SPECIFICATION	6
ADJUSTMENT INSTRUCTION	12
TROUBLE SHOOTING	18
BLOCK DIAGRAM.....	22
EXPLODED VIEW	34
SVC. SHEET	

SAFETY PRECAUTIONS

IMPORTANT SAFETY NOTICE

Many electrical and mechanical parts in this chassis have special safety-related characteristics. These parts are identified by Δ in the Schematic Diagram and Replacement Parts List.

It is essential that these special safety parts should be replaced with the same components as recommended in this manual to prevent Shock, Fire, or other Hazards.

Do not modify the original design without permission of manufacturer.

General Guidance

An **isolation Transformer should always be used** during the servicing of a receiver whose chassis is not isolated from the AC power line. Use a transformer of adequate power rating as this protects the technician from accidents resulting in personal injury from electrical shocks.

It will also protect the receiver and its components from being damaged by accidental shorts of the circuitry that may be inadvertently introduced during the service operation.

If any fuse (or Fusible Resistor) in this TV receiver is blown, replace it with the specified.

When replacing a high wattage resistor (Oxide Metal Film Resistor, over 1W), keep the resistor 10mm away from PCB.

Keep wires away from high voltage or high temperature parts.

Before returning the receiver to the customer,

always perform an **AC leakage current check** on the exposed metallic parts of the cabinet, such as antennas, terminals, etc., to be sure the set is safe to operate without damage of electrical shock.

Leakage Current Cold Check(Antenna Cold Check)

With the instrument AC plug removed from AC source, connect an electrical jumper across the two AC plug prongs. Place the AC switch in the on position, connect one lead of ohm-meter to the AC plug prongs tied together and touch other ohm-meter lead in turn to each exposed metallic parts such as antenna terminals, phone jacks, etc.

If the exposed metallic part has a return path to the chassis, the measured resistance should be between $1M\Omega$ and $5.2M\Omega$.

When the exposed metal has no return path to the chassis the reading must be infinite.

An other abnormality exists that must be corrected before the receiver is returned to the customer.

Leakage Current Hot Check (See below Figure)

Plug the AC cord directly into the AC outlet.

Do not use a line Isolation Transformer during this check.

Connect 1.5K/10watt resistor in parallel with a 0.15uF capacitor between a known good earth ground (Water Pipe, Conduit, etc.) and the exposed metallic parts.

Measure the AC voltage across the resistor using AC voltmeter with 1000 ohms/volt or more sensitivity.

Reverse plug the AC cord into the AC outlet and repeat AC voltage measurements for each exposed metallic part. Any voltage measured must not exceed 0.75 volt RMS which corresponds to 0.5mA.

In case any measurement is out of the limits specified, there is possibility of shock hazard and the set must be checked and repaired before it is returned to the customer.

Leakage Current Hot Check circuit

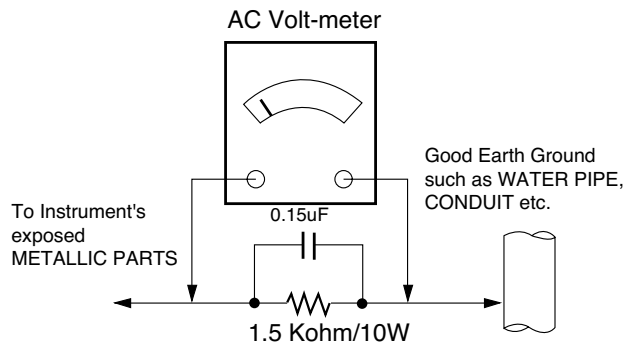

SERVICING PRECAUTIONS

CAUTION: Before servicing receivers covered by this service manual and its supplements and addenda, read and follow the SAFETY PRECAUTIONS on page 3 of this publication.

NOTE: If unforeseen circumstances create conflict between the following servicing precautions and any of the safety precautions on page 3 of this publication, always follow the safety precautions. Remember: Safety First.

General Servicing Precautions

1. Always unplug the receiver AC power cord from the AC power source before;
 - a. Removing or reinstalling any component, circuit board module or any other receiver assembly.
 - b. Disconnecting or reconnecting any receiver electrical plug or other electrical connection.
 - c. Connecting a test substitute in parallel with an electrolytic capacitor in the receiver.
CAUTION: A wrong part substitution or incorrect polarity installation of electrolytic capacitors may result in an explosion hazard.

2. Test high voltage only by measuring it with an appropriate high voltage meter or other voltage measuring device (DVM, FETVOM, etc) equipped with a suitable high voltage probe. Do not test high voltage by "drawing an arc".
3. Do not spray chemicals on or near this receiver or any of its assemblies.
4. Unless specified otherwise in this service manual, clean electrical contacts only by applying the following mixture to the contacts with a pipe cleaner, cotton-tipped stick or comparable non-abrasive applicator; 10% (by volume) Acetone and 90% (by volume) isopropyl alcohol (90%-99% strength)
CAUTION: This is a flammable mixture.
Unless specified otherwise in this service manual, lubrication of contacts is not required.
5. Do not defeat any plug/socket B+ voltage interlocks with which receivers covered by this service manual might be equipped.
6. Do not apply AC power to this instrument and/or any of its electrical assemblies unless all solid-state device heat sinks are correctly installed.
7. Always connect the test receiver ground lead to the receiver chassis ground before connecting the test receiver positive lead.
Always remove the test receiver ground lead last.
8. Use with this receiver only the test fixtures specified in this service manual.
CAUTION: Do not connect the test fixture ground strap to any heat sink in this receiver.

Electrostatically Sensitive (ES) Devices

Some semiconductor (solid-state) devices can be damaged easily by static electricity. Such components commonly are called Electrostatically Sensitive (ES) Devices. Examples of typical ES devices are integrated circuits and some field-effect transistors and semiconductor "chip" components. The following techniques should be used to help reduce the incidence of component damage caused by static by static electricity.

1. Immediately before handling any semiconductor component or semiconductor-equipped assembly, drain off any electrostatic charge on your body by touching a known earth ground. Alternatively, obtain and wear a commercially available discharging wrist strap device, which should be removed to prevent potential shock reasons prior to applying power to the

unit under test.

2. After removing an electrical assembly equipped with ES devices, place the assembly on a conductive surface such as aluminum foil, to prevent electrostatic charge buildup or exposure of the assembly.
3. Use only a grounded-tip soldering iron to solder or unsolder ES devices.
4. Use only an anti-static type solder removal device. Some solder removal devices not classified as "anti-static" can generate electrical charges sufficient to damage ES devices.
5. Do not use freon-propelled chemicals. These can generate electrical charges sufficient to damage ES devices.
6. Do not remove a replacement ES device from its protective package until immediately before you are ready to install it. (Most replacement ES devices are packaged with leads electrically shorted together by conductive foam, aluminum foil or comparable conductive material).
7. Immediately before removing the protective material from the leads of a replacement ES device, touch the protective material to the chassis or circuit assembly into which the device will be installed.
CAUTION: Be sure no power is applied to the chassis or circuit, and observe all other safety precautions.
8. Minimize bodily motions when handling unpackaged replacement ES devices. (Otherwise harmless motion such as the brushing together of your clothes fabric or the lifting of your foot from a carpeted floor can generate static electricity sufficient to damage an ES device.)

General Soldering Guidelines

1. Use a grounded-tip, low-wattage soldering iron and appropriate tip size and shape that will maintain tip temperature within the range or 500°F to 600°F.
2. Use an appropriate gauge of RMA resin-core solder composed of 60 parts tin/40 parts lead.
3. Keep the soldering iron tip clean and well tinned.
4. Thoroughly clean the surfaces to be soldered. Use a mall wire-bristle (0.5 inch, or 1.25cm) brush with a metal handle.
Do not use freon-propelled spray-on cleaners.
5. Use the following unsoldering technique
 - a. Allow the soldering iron tip to reach normal temperature. (500°F to 600°F)
 - b. Heat the component lead until the solder melts.
 - c. Quickly draw the melted solder with an anti-static, suction-type solder removal device or with solder braid.
CAUTION: Work quickly to avoid overheating the circuit board printed foil.
6. Use the following soldering technique.
 - a. Allow the soldering iron tip to reach a normal temperature (500°F to 600°F)
 - b. First, hold the soldering iron tip and solder the strand against the component lead until the solder melts.
 - c. Quickly move the soldering iron tip to the junction of the component lead and the printed circuit foil, and hold it there only until the solder flows onto and around both the component lead and the foil.
CAUTION: Work quickly to avoid overheating the circuit board printed foil.
 - d. Closely inspect the solder area and remove any excess or splashed solder with a small wire-bristle brush.

IC Remove/Replacement

Some chassis circuit boards have slotted holes (oblong) through which the IC leads are inserted and then bent flat against the circuit foil. When holes are the slotted type, the following technique should be used to remove and replace the IC. When working with boards using the familiar round hole, use the standard technique as outlined in paragraphs 5 and 6 above.

Removal

1. Desolder and straighten each IC lead in one operation by gently prying up on the lead with the soldering iron tip as the solder melts.
2. Draw away the melted solder with an anti-static suction-type solder removal device (or with solder braid) before removing the IC.

Replacement

1. Carefully insert the replacement IC in the circuit board.
2. Carefully bend each IC lead against the circuit foil pad and solder it.
3. Clean the soldered areas with a small wire-bristle brush.
(It is not necessary to reapply acrylic coating to the areas).

"Small-Signal" Discrete Transistor Removal/Replacement

1. Remove the defective transistor by clipping its leads as close as possible to the component body.
2. Bend into a "U" shape the end of each of three leads remaining on the circuit board.
3. Bend into a "U" shape the replacement transistor leads.
4. Connect the replacement transistor leads to the corresponding leads extending from the circuit board and crimp the "U" with long nose pliers to insure metal to metal contact then solder each connection.

Power Output, Transistor Device Removal/Replacement

1. Heat and remove all solder from around the transistor leads.
2. Remove the heat sink mounting screw (if so equipped).
3. Carefully remove the transistor from the heat sink of the circuit board.
4. Insert new transistor in the circuit board.
5. Solder each transistor lead, and clip off excess lead.
6. Replace heat sink.

Diode Removal/Replacement

1. Remove defective diode by clipping its leads as close as possible to diode body.
2. Bend the two remaining leads perpendicular y to the circuit board.
3. Observing diode polarity, wrap each lead of the new diode around the corresponding lead on the circuit board.
4. Securely crimp each connection and solder it.
5. Inspect (on the circuit board copper side) the solder joints of the two "original" leads. If they are not shiny, reheat them and if necessary, apply additional solder.

Fuse and Conventional Resistor Removal/Replacement

1. Clip each fuse or resistor lead at top of the circuit board hollow stake.
2. Securely crimp the leads of replacement component around notch at stake top.
3. Solder the connections.

CAUTION: Maintain original spacing between the replaced component and adjacent components and the circuit board to prevent excessive component temperatures.

Circuit Board Foil Repair

Excessive heat applied to the copper foil of any printed circuit board will weaken the adhesive that bonds the foil to the circuit board causing the foil to separate from or "lift-off" the board. The following guidelines and procedures should be followed whenever this condition is encountered.

At IC Connections

To repair a defective copper pattern at IC connections use the following procedure to install a jumper wire on the copper pattern side of the circuit board. (Use this technique only on IC connections).

1. Carefully remove the damaged copper pattern with a sharp knife. (Remove only as much copper as absolutely necessary).
2. Carefully scratch away the solder resist and acrylic coating (if used) from the end of the remaining copper pattern.
3. Bend a small "U" in one end of a small gauge jumper wire and carefully crimp it around the IC pin. Solder the IC connection.
4. Route the jumper wire along the path of the out-away copper pattern and let it overlap the previously scraped end of the good copper pattern. Solder the overlapped area and clip off any excess jumper wire.

At Other Connections

Use the following technique to repair the defective copper pattern at connections other than IC Pins. This technique involves the installation of a jumper wire on the component side of the circuit board.

1. Remove the defective copper pattern with a sharp knife. Remove at least 1/4 inch of copper, to ensure that a hazardous condition will not exist if the jumper wire opens.
2. Trace along the copper pattern from both sides of the pattern break and locate the nearest component that is directly connected to the affected copper pattern.
3. Connect insulated 20-gauge jumper wire from the lead of the nearest component on one side of the pattern break to the lead of the nearest component on the other side. Carefully crimp and solder the connections.
CAUTION: Be sure the insulated jumper wire is dressed so the it does not touch components or sharp edges.

SPECIFICATION

NOTE : Specifications and others are subject to change without notice for improvement.

1. Application range

This specification is applied to the LCD TV used LB81B/C chassis.

2. Requirement for Test

Each part is tested as below without special appointment.

- 1) Temperature : 25±5°C (77±9°F), CST : 40±5°C
- 2) Relative Humidity : 65±10%
- 3) Power Voltage : Standard input voltage(100~240V@50/60Hz)
* Standard Voltage of each products is marked by models.
- 4) Specification and performance of each parts are followed each drawing and specification by part number in accordance with BOM.
- 5) The receiver must be operated for about 20 minutes prior to the adjustment.

3. Test method

- 1) Performance: LGE TV test method followed
- 2) Demanded other specification
 - Safety: CB specification
 - EMC: CISPR 13 specification

4. General specification

Item	Specification	Remark
Broadcasting system	PAL-BG, DTV:DVB-T	
Available Channel	1) VHF : 00~12 2) UHF : 20~75 3) CATV : 02~44 4) DTV : 06~12, 27~69	
Tuner IF	1) PAL : 38.90MHz(Picture), 34.40MHz(Sound) 2) DVB-T : 36.125MHz	
Input Voltage	AC 100~240V, 50/60Hz	
Screen Size	42 inch Wide (1920 x 1080) 47 inch Wide (1920 x 1080) 52 inch Wide (1920 x 1080)	
Aspect Ratio	16:9	
Module	LC420WUE-SAB1 LC470WUE-SAB1 LC420WUF-SAB1 LC470WUF-SAB1 LK520D3LZ9X LC420WUF-SSA LC470WUF-SAT1	42LG60FD-AB 47LG60FD-AB 42LG65YD-AA 47LG65YD-AC 52LG65YD-AC 42LG61YD-AC 47LG61YD-AC
Operating Environment	1) Temp : 0 ~ 40 deg 2) Humidity : ~ 80 %	LGE Spec
Storage Environment	1) Temp : -20 ~ 60 deg 2) Humidity : ~ 85 %	

5. Chrominance & Luminance Specification

5-1. 42LG65YD-AC

No	Item	Min	Typ	Max	Unit	Remark	
1.	White peak brightness	400	500		cd/m ²		
2.	Contrast ratio				cd/m ²	N/A	
3.	Brightness uniformity	70			%	Full white	
4.	Color coordinate	RED	X	Typ. -0.03	0.640	Typ. +0.03	Color coordinate
			Y		0.335		
		GREEN	X	0.289			
			Y	0.610			
		BLUE	X	0.144			
			Y	0.066			
		WHITE	X	0.279			
			Y	0.292			
5.	Color coordinate uniformity					N/A	
6.	Contrast ratio	1000	1400			All mode except RGB/HDMI-PC (With PWM Dimining) RGB/HDMI-PC (Without PWM Dimining)	
7.	Color Distortion, DG			TBD	%		
8.	Color Distortion, DP			TBD	deg		
9.	Color S/N, AM/FM	TBD			dB		
10.	Color Killer Sensitivity	TBD			dBm		

5-2. 47LG65YD-AC

No	Item	Min	Typ	Max	Unit	Remark	
1.	White peak brightness	400	500		cd/m ²		
2.	Contrast ratio				cd/m ²	N/A	
3.	Brightness uniformity	70			%	Full white	
4.	Color coordinate	RED	X	Typ. -0.03	0.638	Typ. +0.03	Color coordinate
			Y		0.335		
		GREEN	X	0.289			
			Y	0.609			
		BLUE	X	0.145			
			Y	0.063			
		WHITE	X	0.279			
			Y	0.292			
5.	Color coordinate uniformity					N/A	
6.	Contrast ratio	900	1300			All mode except RGB/HDMI-PC (With PWM Dimining) RGB/HDMI-PC (Without PWM Dimining)	
7.	Color Distortion, DG			TBD	%		
8.	Color Distortion, DP			TBD	deg		
9.	Color S/N, AM/FM	TBD			dB		
10.	Color Killer Sensitivity	TBD			dBm		

5-3. 52LG65YD-AC

No	Item	Min	Typ	Max	Unit	Remark	
1.	White peak brightness	360	450		cd/m ²		
2.	Contrast ratio				cd/m ²	N/A	
3.	Brightness uniformity	70			%	Full white	
4.	Color coordinate	RED	X	Typ. -0.03	0.640	Typ. +0.03	Color coordinate
			Y		0.330		
		GREEN	X	0.280			
			Y	0.600			
		BLUE	X	0.150			
			Y	0.060			
		WHITE	X	0.272			
			Y	0.277			
5.	Color coordinate uniformity					N/A	
6.	Contrast ratio					All mode except RGB/HDMI-PC (With PWM Dimining) RGB/HDMI-PC (Without PWM Dimining)	
7.	Color Distortion, DG			TBD	%		
8.	Color Distortion, DP			TBD	deg		
9.	Color S/N, AM/FM	TBD			dB		
10.	Color Killer Sensitivity	TBD			dBm		

5-4. 42LG61YD-AC

No	Item	Min	Typ	Max	Unit	Remark	
1.	White peak brightness	360	450		cd/m ²		
2.	Contrast ratio				cd/m ²	N/A	
3.	Brightness uniformity	70			%	Full white	
4.	Color coordinate	RED	X	Typ. -0.03	0.640	Typ. +0.03	Color coordinate
			Y		0.335		
		GREEN	X	0.289			
			Y	0.610			
		BLUE	X	0.144			
			Y	0.066			
		WHITE	X	0.279			
			Y	0.292			
5.	Color coordinate uniformity					N/A	
6.	Contrast ratio	1000 (800)	1400 (1000)			All mode except RGB/HDMI-PC (With PWM Dimining) RGB/HDMI-PC (Without PWM Dimining)	
7.	Color Distortion, DG			TBD	%		
8.	Color Distortion, DP			TBD	deg		
9.	Color S/N, AM/FM	TBD			dB		
10.	Color Killer Sensitivity	TBD			dBm		

5-5. 47LG61YD-AC

No	Item	Min	Typ	Max	Unit	Remark	
1.	White peak brightness	360	450		cd/m ²		
2.	Contrast ratio				cd/m ²	N/A	
3.	Brightness uniformity	70			%	Full white	
4.	Color coordinate	RED	X	Typ. -0.03	0.638	Typ. +0.03	Color coordinate
			Y		0.335		
		GREEN	X	0.289			
			Y	0.610			
		BLUE	X	0.145			
			Y	0.063			
		WHITE	X	0.279			
			Y	0.292			
5.	Color coordinate uniformity					N/A	
6.	Contrast ratio	900	1300			All mode except RGB/HDMI-PC (With PWM Dimining) RGB/HDMI-PC (Without PWM Dimining)	
7.	Color Distortion, DG			TBD	%		
8.	Color Distortion, DP			TBD	deg		
9.	Color S/N, AM/FM	TBD			dB		
10.	Color Killer Sensitivity	TBD			dBm		

6. Component Video Input (Y, Cb/Pb, Cr/Pr)

No	Specification			Remark
	Resolution	H-freq(kHz)	V-freq(Hz)	
1	720x480	15.73	59.94	SDTV, DVD 480i
2	720x480	15.75	60	SDTV, DVD 480i
3	720x480	31.47	59.94	SDTV 480p
4	720X480	31.5	60	SDTV 480p
5	720x576	15.625	50	SDTV, DVD 576i
6	720x576	31.25	50	SDTV 576p
7	1280x720	44.96	59.94	HDTV 720p
8	1280x720	45	60.36	HDTV 720p
9	1280x720	37.5	50	HDTV 720p
10	1920x1080	28.125	50	HDTV 1080i
11	1920x1080	33.75	60	HDTV 1080i
12	1920x1080	33.72	59.94	HDTV 1080i
13	1920x1080	56.25	50	HDTV 1080p
14	1920x1080	67.433	59.94	HDTV 1080p
15	1920x1080	67.5	60	HDTV 1080p

7. RGB PC INPUT

No	Resolution	H-freq(kHz)	V-freq.(Hz)	Pixel clock(MHz)	Proposed	Remark
1	720*400	31.468	70.08	28.321		
2	640*480	31.469	59.94	25.17	VESA	Input 848*480 60Hz, 852*480 60Hz => 640*480 60Hz Display
3	800*600	37.879	60.31	40.00	VESA	
4	1024*768	48.363	60.00	65.00	VESA(XGA)	
5	1280*768	47.78	59.87	79.5	WXGA	
6	1360*768	47.72	59.8	84.75	WXGA	
7	1366*768	47.56	59.6	84.75	WXGA	
8	1280*1024	63.595	60.0	108.875	SXGA	FHD Model only
9	1920*1080	66.647	59.988	138.625	WUXGA	FHD Model only

8. HDMI Input (PC/DTV)

No	Resolution	H-freq(kHz)	V-freq.(Hz)	Pixel clock(MHz)	Proposed	Remark
PC						
1	720*400	31.468	70.08	28.321		HDCP
2	640*480	31.469	59.94	25.17	VESA	HDCP
3	800*600	37.879	60.31	40.00	VESA	HDCP
4	1024*768	48.363	60.00	65.00		
5	1280*768	47.78	59.87	79.5	WXGA	HDCP
6	1360*768	47.72	59.8	84.75	WXGA	HDCP
7	1366*768	47.56	59.6	84.75	WXGA	HDCP
8	1280*1024	63.595	60.0	108.875	SXGA	FHD Model only, HDCP
9	1920*1080	66.647	59.988	138.625	WUXGA	FHD Model only, HDCP
DTV						
1	720*480	31.47	59.94	27.00	SDTV 480P(4:3)	
2	720*480	31.50	60	27.027	SDTV 480P(4:3)	
3	640*480	31.469	59.94	25.175	SDTV 480P(4:3)	
4	640*480	31.469	60.00	25.20	SDTV 480P(4:3)	
5	720*480	31.47	59.94	27.000	SDTV 480P(16:9)	
6	720*480	31.50	60.00	27.027	SDTV 480P(16:9)	
7	720*576	31.25	50.00	27.000	SDTV 576P	
8	1280*720	37.50	50.00	74.176	HDTV 720P	HDCP
9	1280*720	44.96	59.94	74.176	HDTV 720P	HDCP
10	1280*720	45.00	60.00	74.250	HDTV 720P	
11	1920*1080	33.72	59.94	74.176	HDTV 1080I	HDCP
12	1920*1080	33.75	60.00	74.250	HDTV 1080I	HDCP
13	1920*1080	28.125	50.00	74.250	HDTV 1080I 50 Hz	HDCP
14	1920*1080	27.000	24.00	74.250	HDTV 1080P 24Hz	HDCP
15	1920*1080	56.250	50	148.500	HDTV 1080P 50Hz	HDCP
16	1920*1080	67.433	59.94	148.352	HDTV 1080P	HDCP
17	1920*1080	67.500	60	148.500	HDTV 1080P	HDCP

ADJUSTMENT INSTRUCTION

1. Application Range

This specification sheet is applied to all of the LCD TV with LB81C chassis.

2. Designation

- 1) The adjustment is according to the order which is designated and which must be followed, according to the plan which can be changed only on agreeing.
- 2) Power Adjustment: Free Voltage
- 3) Magnetic Field Condition: Nil.
- 4) Input signal Unit: Product Specification Standard
- 5) Reserve after operation: Above 5 Minutes (Heat Run)
Temperature : at 25±5°C
Relative humidity : 65±10%
Input voltage : 220V, 60Hz
- 6) Adjustment equipments: Color Analyzer (CA-210 or CA-110), Pattern Generator (MSPG-925L or Equivalent), DDC Adjustment Jig equipment, SVC remote controller
- 7) Don't push The "IN STOP KEY" after completing the function inspection.

3. Main PCB check process

* APC - After Manual-Insult, executing APC

* Download

- 1) Execute ISP program "Mstar ISP Utility" and then click "Config" tab.
- 2) Set as below, and then click "Auto Detect" and check "OK" message. If display "Error", Check connect computer, jig, and set.
- 3) Click "Connect" tab. If display "Can't", Check connect computer, jig, and set.

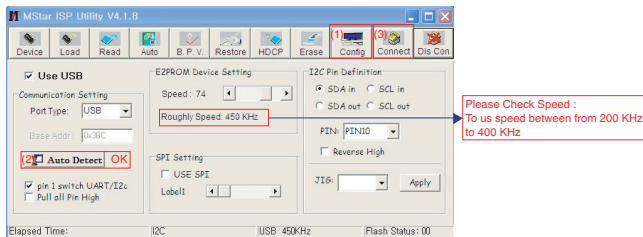

- 4) Click "Read" tab, and then load download file(XXXX.bin) by clicking "Read".

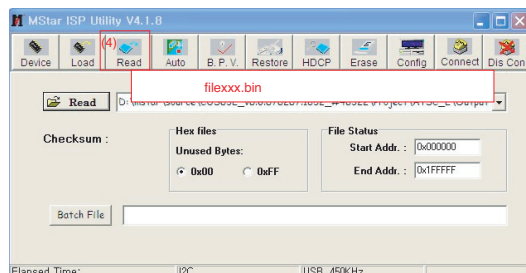

5. Click "Auto" tab and set as below
6. Click "Run".
7. After downloading, check "OK" message.

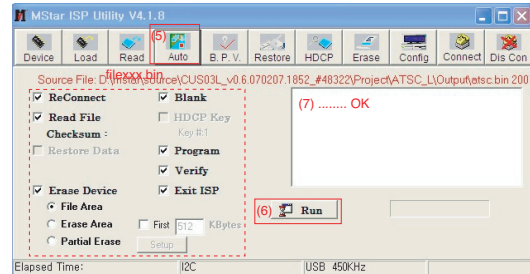

* USB DOWNLOAD

- 1) Put the USB Stick to the USB socket

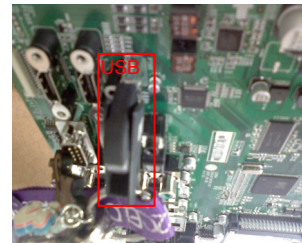

- 2) Automatically detecting update file in USB Stick
- If your downloaded program version in USB Stick is Low, it didn't work. But your downloaded version is High, USB data is automatically detecting
- 3) Show the message "Copying files from memory"

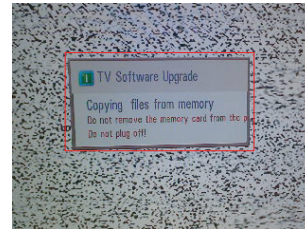

- 4) Updating is starting.

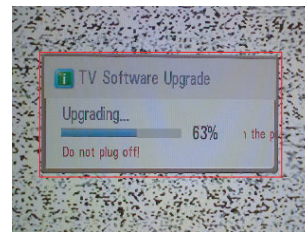

- 5) Fishing the version uploading, you have to put USB stick and "AC Power" off.

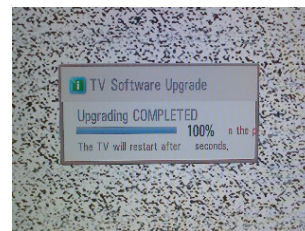

- 6) After putting "AC Power" on and check updated version on your TV.

*** After downloading, have to adjust Tool Option again.**

- 1) Push "IN-START" key in service remote controller
- 2) Select "MODEL SELECT" and Push "OK" button.
- 3) Go To "INCH" and choice proper inch.
- 4) TV power turn off and on.
- 5) Completed selecting Tool option

3.1. ADC Process

(1) PC input ADC

- 1) Auto RGB Gain/Offset Adjustment
 - Convert to PC in Input-source
 - Signal equipment displays
Output Voltage : 700 mVp-p
Impress Resolution XGA (1024 x 768 @ 60Hz)
Model : 60 in Pattern Generator
Pattern : 65 in Pattern Generator (MSPG-925 Series, MSPG-1025D) - 7 color bar.
[gray pattern that left & right is black and center is white signal(Refer below picture)]

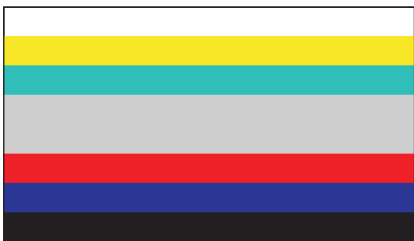

<Fig. 1> Adjustment pattern(PC)

- Adjust by commanding AUTO_COLOR_ADJUST.

- 2) Confirmation
 - We confirm whether "0xAA (RGB)" address of EEPROM "0xA2" is "0xAA" or not.
 - If "0xAA (RGB)" address of EEPROM "0xA2" isn't "0xAA", we adjust once more
 - We can confirm the ADC values from "0xA4~0xA9 (RGB)" addresses in a page "0xA2"

* Manual ADC process using Service Remocon. After enter Service Mode by pushing "ADJ" key, execute "ADC Adjust" by pushing "▶" key at "ADC CALIBRATION: RGB-PC".

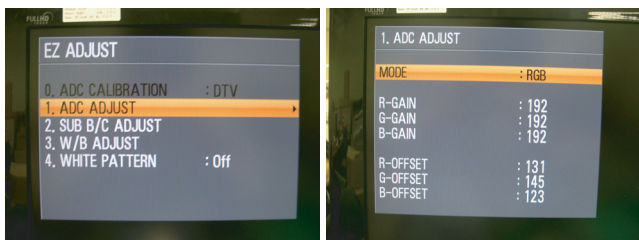

(2) COMPONENT input ADC

- 1) Component Gain/Offset Adjustment
 - Convert to Component in Input-source
 - Signal equipment displays
Impress Resolution 480i
MODEL : 209 in Pattern Generator(480i Mode)
Pattern : 65 in Pattern Generator (MSPG-925 Series, MSPG-1025D) - 7 color bar.

Impress Resolution 1080i
Model : 223 in Pattern Generator(1080i Mode)
Pattern: 65 in Pattern Generator (MSPG-925 Series, MSPG-1025D) - 7 color bar.
- Adjust by commanding AUTO_COLOR_ADJUST.

- 2) Confirmation
 - We confirm whether "0xB3 (480i)/0xBC (1080i)" address of EEPROM "0xA2" is "0xAA" or not.
 - If "0xB3 (480i)/0xBC(1080i)" address of EEPROM "0xA2" isn't "0xAA", we adjust once more.
 - We can confirm the ADC values from "0xAD~0XB2 (480i)/0XB6~BB (1080i)" addresses in a page "0xA2".

* Manual ADC process using Service Remocon. After enter Service Mode by pushing "ADJ" key, execute "ADC Adjust" by pushing "▶" key at "ADC CALIBRATION : COMPONENT".

Impress Resolution 480i

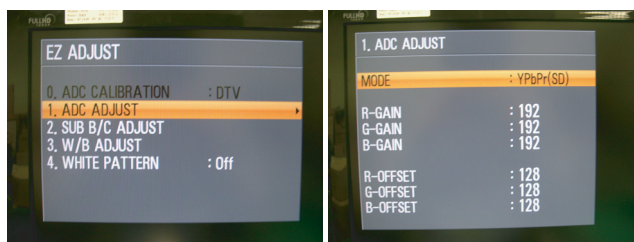

Impress Resolution 1080i

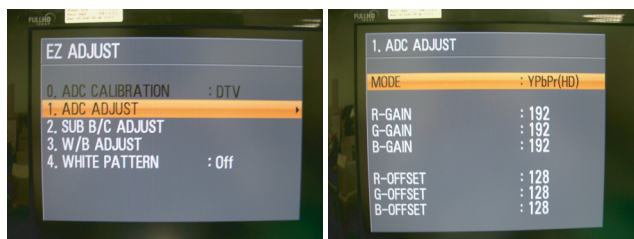

3.2. Function Check

(1) Check display and sound

- Check Input and Signal items. (cf. work instructions)
 - 1) TV
 - 2) AV
 - 3) COMPONENT (480i)
 - 4) RGB (PC : 1024 x 768 @ 60hz)
 - 5) HDMI
 - 6) PC Audio In

* Display and Sound check is executed by Remote controller.

4. Total Assembly line process

4.1. Adjustment Preparation

- (1) W/B Equipment condition
CA210: CH 9, Test signal: Inner pattern (85IRE)
- (2) Above 5 minutes H/run in the inner pattern. ("power on" key of adjust remote control)
- (3) 15 Pin D-Sub Jack is connected to the AUTO W/B EQUIPMENT.
- (4) Adjust Process will start by execute I2C Command (Inner pattern (0xF3, 0xFF)).

Color Temperature	Cool	11,000	°K	X=0.276(±0.002) Y=0.283(±0.002)	<Test Signal> Inner pattern (216gray,85IRE)
	Medium	9,300	°K	X=0.285(±0.002) Y=0.293(±0.002)	
	Warm	6,500	°K	X=0.313(±0.002) Y=0.329(±0.002)	

- (5) Adjust Process will finish by execute I2C Command (Inner pattern (Inner pattern (0xF3,0x00))).

** Caution **

Color Temperature: COOL, Medium, Warm
One of R Gain/G Gain/ B Gain should be kept on 0xC0, and adjust other two lower than C0.
(when R/G/B Gain are all C0, it is the FULL Dynamic Range of Module)

* Manual W/B process using adjusts Remote control.

- After enter Service Mode by pushing "ADJ" key,
- Enter White Pattern off of service mode, and change off ---> on.
- Enter "W/B ADJUST" by pushing "▶" key at "3.W/B ADJUST".
- The default value of RGB-GAIN is 192 at cool, Medium, Warm
(There is a difference between picture image and set)



- * After done all adjustments, Press "In-start" button and compare Tool option and Area option value with its BOM, if it is correctly same then unplug the AC cable.
If it is not same, then correct it same with BOM and unplug AC cable.
For correct it to the model's module from factory JIG model.

- * Don't push The "IN STOP KEY" after completing the function inspection.

4.2. DPM operation confirmation

(Only Apply for MNT Model)

Check if Power LED Color and Power Consumption operate as standard.

- Set Input to RGB and connect D-sub cable to set
- Measurement Condition: (100-240V@ 50/60Hz)
- Confirm DPM operation at the state of screen without Signal

4.3. DDC EDID Write (RGB 128Byte)

- Connect D-sub signal cable to D-sub Jack.
- Write EDID Data to EEPROM(24C02) by using DDC2B protocol.
- Check whether written EDID data is correct or not.

4.4. DDC EDID Write (HDMI 256Byte)

In case of 2008 year new model for Australia and Taiwan which is developed with Mstar scaler, Manufacture gave no use for downlad of EDID for HDMI 1/2/3/4 because HDMI EDID data is in the Application Program.

4.5. LB81C EDID Data

(42LG60FD-AA, 47LG60FD-AA, 42LG65YD-AC, 47LG65YD-AA, 52LG65YD-AA, 42LG61YD-AC, 47LG61YD-AC)
No USE the EDID data of Digital data(HDMI 1, 2, 3, 4) and Analog EDID data (RGB) As EDID data is recorded in the Mstar (Main IC).

4.5.1 Analog data 128Byte(2Bi) - Not USE

	0	1	2	3	4	5	6	7	8	9	A	B	C	D	E	F
0	00	FF	FF	FF	FF	FF	FF	00	1E	6D	FB	9C	01	01	01	01
10	0A	12	01	03	01	46	27	78	EA	D9	B0	A3	57	49	9C	25
20	11	49	4B	A5	4E	00	31	40	45	40	61	40	81	80	01	01
30	01	01	D1	C0	01	01	1A	36	80	A0	70	38	1F	40	30	20
40	35	00	E8	26	32	00	00	1A	1B	21	50	A0	51	00	1E	30
50	48	88	35	00	BC	86	21	00	00	1C	00	00	00	FD	00	39
60	4B	1F	54	12	00	0A	20	20	20	20	20	20	00	00	00	FC
70	00	4C	47	20	54	56	0A	20	20	20	20	20	20	20	00	E4

EDID block 0, Bytes 0-127[00H-7FH]

Block Type : EDID 1.3

4.5.2 Digital data(HDMI-1) 256Byte

	0	1	2	3	4	5	6	7	8	9	A	B	C	D	E	F
0	00	FF	FF	FF	FF	FF	FF	00	1E	6D	F	9C	01	01	01	01
10	0A	12	01	03	80	46	27	78	EA	D9	B0	A3	57	49	9C	25
20	11	49	4B	A1	0C	00	31	40	45	40	61	40	81	80	01	01
30	01	01	D1	C0	01	01	1A	36	80	A0	70	38	1F	40	30	20
40	35	00	E8	26	32	00	00	1A	1B	21	50	A0	51	00	1E	30
50	48	88	35	00	BC	86	21	00	00	1C	00	00	00	FD	00	39
60	4B	1F	54	12	00	0A	20	20	20	20	20	20	00	00	00	FC
70	00	4C	47	20	54	56	0A	20	20	20	20	20	20	20	01	A9

EDID block 0, Bytes 0-127[00H-7FH]

Block Type : EDID 1.3

	0	1	2	3	4	5	6	7	8	9	A	B	C	D	E	F
0	02	03	23	F1	4E	81	02	03	15	12	13	04	14	05	20	21
10	22	1F	10	23	15	07	50	83	01	00	00	67	03	0C	00	10
20	00	B8	2D	01	1D	00	80	51	D0	1C	20	40	80	35	00	BC
30	88	21	00	00	1E	8C	0A	D0	8A	20	E0	2D	10	10	3E	96
40	00	13	8E	21	00	00	18	02	3A	80	18	71	38	2D	40	58
50	2C	45	00	06	44	21	00	00	1E	01	1D	80	18	71	1C	16
60	20	58	2C	25	00	C4	8E	21	00	00	9E	4E	1F	00	80	51
70	00	1E	30	40	80	37	00	BC	88	21	00	00	18	00	00	DF

4.5.3 Digital data(HDMI-2) 256Byte - Not USE

EDID Block 0, Byte 0-127[00H-7FH]
Block Type : EDID 1.3

0	0	1	2	3	4	5	6	7	8	9	A	B	C	D	E	F
0	00	FF	FF	FF	FF	FF	FF	00	1E	6D	FC	9C	01	01	01	01
10	0A	12	01	03	80	46	27	78	EA	D9	B0	A3	57	49	9C	25
20	11	49	4B	A1	0C	00	31	40	45	40	61	40	81	80	01	01
30	01	01	D1	C0	01	01	1A	36	80	A0	70	38	1F	40	30	20
40	35	00	E8	26	32	00	00	1A	1B	21	50	A0	51	00	1E	30
50	48	88	35	00	BC	86	21	00	00	1C	00	00	00	FD	00	39
60	4B	1F	54	12	00	0A	20	20	20	20	20	20	00	00	00	FC
70	00	4C	47	20	54	56	0A	20	20	20	20	20	20	01	01	A9

EDID block 1, Bytes 128-255[80H- FFH]
Block Type : CEA EDID Timing Extension Version 3.

0	1	2	3	4	5	6	7	8	9	A	B	C	D	E	F	
0	02	03	23	F1	4E	81	02	03	15	12	13	04	14	05	20	21
10	22	1F	10	23	15	07	50	83	01	00	00	67	03	0C	00	20
20	00	B0	2D	01	1D	00	80	51	D0	1C	20	40	80	35	00	BC
30	88	21	00	00	1E	8C	0A	D0	8A	20	E0	2D	10	10	3E	96
40	00	13	8E	21	00	00	18	02	3A	80	18	71	38	2D	40	58
50	2C	45	00	06	44	21	00	00	1E	01	1D	80	18	71	1C	16
60	20	58	2C	25	00	C4	8E	21	00	00	9E	4E	1F	00	80	51
70	00	1E	30	40	80	37	00	BC	88	21	00	00	18	00	00	CF

4.5.4 Digital data(HDMI-3) 256Byte - Not USE

EDID Block 0, Byte 0-127[00H-7FH]
Block Type : EDID 1.3

0	1	2	3	4	5	6	7	8	9	A	B	C	D	E	F	
0	00	FF	FF	FF	FF	FF	FF	00	1E	6D	FC	9C	01	01	01	01
10	0A	12	01	03	80	46	27	78	EA	D9	B0	A3	57	49	9C	25
20	11	49	4B	A1	0C	00	31	40	45	40	61	40	81	80	01	01
30	01	01	D1	C0	01	01	1A	36	80	A0	70	38	1F	40	30	20
40	35	00	E8	26	32	00	00	1A	1B	21	50	A0	51	00	1E	30
50	48	88	35	00	BC	86	21	00	00	1C	00	00	00	FD	00	39
60	4B	1F	54	12	00	0A	20	20	20	20	20	20	00	00	00	FC
70	00	4C	47	20	54	56	0A	20	20	20	20	20	20	01	01	A9

EDID block 1, Bytes 128-255[80H- FFH]
Block Type : CEA EDID Timing Extension Version 3.

0	1	2	3	4	5	6	7	8	9	A	B	C	D	E	F	
0	02	03	23	F1	4E	81	02	03	15	12	13	04	14	05	20	21
10	22	1F	10	23	15	07	50	83	01	00	00	67	03	0C	00	30
20	00	B0	2D	01	1D	00	80	51	D0	1C	20	40	80	35	00	BC
30	88	21	00	00	1E	8C	0A	D0	8A	20	E0	2D	10	10	3E	96
40	00	13	8E	21	00	00	18	02	3A	80	18	71	38	2D	40	58
50	2C	45	00	06	44	21	00	00	1E	01	1D	80	18	71	1C	16
60	20	58	2C	25	00	C4	8E	21	00	00	9E	4E	1F	00	80	51
70	00	1E	30	40	80	37	00	BC	88	21	00	00	18	00	00	BF

4.5.5 Digital data(HDMI-4) 256Byte - Not USE

EDID Block 0, Byte 0-127[00H-7FH]
Block Type : EDID 1.3

0	1	2	3	4	5	6	7	8	9	A	B	C	D	E	F	
0	00	FF	FF	FF	FF	FF	FF	00	1E	6D	FC	9C	01	01	01	01
10	0A	12	01	03	80	46	27	78	EA	D9	B0	A3	57	49	9C	25
20	11	49	4B	A1	0C	00	31	40	45	40	61	40	81	80	01	01
30	01	01	D1	C0	01	01	1A	36	80	A0	70	38	1F	40	30	20
40	35	00	E8	15	21	00	00	1A	1B	21	50	A0	51	00	1E	30
50	48	88	35	00	BC	86	21	00	00	1C	00	00	00	FD	00	39
60	4B	1F	54	12	00	0A	20	20	20	20	20	20	00	00	00	FC
70	00	4C	47	20	54	56	0A	20	20	20	20	20	20	01	01	A9

EDID block 1, Bytes 128-255[80H- FFH]
Block Type : CEA EDID Timing Extension Version 3.

0	1	2	3	4	5	6	7	8	9	A	B	C	D	E	F	
0	02	03	23	F1	4E	81	02	03	15	12	13	04	14	05	20	21
10	22	1F	10	23	15	07	50	83	01	00	00	67	03	0C	00	40
20	00	B8	2D	01	1D	00	80	51	D0	1C	20	40	80	35	00	BC
30	88	21	00	00	1E	8C	0A	D0	8A	20	E0	2D	10	10	3E	96
40	00	13	8E	21	00	00	18	02	3A	80	18	71	38	2D	40	58
50	2C	45	00	06	44	21	00	00	1E	01	1D	80	18	71	1C	16
60	20	58	1C	14	00	C4	8E	21	00	00	9E	4E	1F	00	80	51
70	00	1E	30	40	80	37	00	BC	88	21	00	00	18	00	00	AF

- 1) All Data : HEXA Value
- 2) Changeable Data :
 - *: Serial No : Controlled / Data:01
 - ** : Month : Controlled / Data:00
 - ***:Year : Controlled
 - ****:Check sum

4.6. HDCP (High-Bandwidth Digital Contents Protection)

SETTING (Scaler : Mstar)

Because HDCP keys built in HDCP exclusive EEPROM, Download progress is not needed.

HDCP-KEY

0:0x80

89 38 AE 0D ED 40 E6 BB FA 4E DE 51 FB 8E D9 AA
34 A8 C4 EA D8 6C DC 5C 91 5C B1 A6 13 2B 8B 8B
F7 46 CC 1C 88 20 A3 27 0E E1 28 84 89 39 A3 E2
36 86 CE 67 EB A0 F2 35 6B 86 F5 21 71 95 8A 77
A1 28 77 97 D3 7B EF 5C 15 48 AA 9E 97 39 CD 98
40 5E 68 56 66 EF C1 3C E1 8F 2A 82 DE 8F 52 CC
A8 1F 37 D9 D4 C6 24 16 7E 42 FF 57 CD 6B E0 86
00 1A F1 19 5A AF 37 97 86 BA 83 29 FE 41 A8 D5

A1:0x00

F4 73 43 03 23 22 C5 28 96 9E 35 0D 67 A8 8B DD
7A 89 38 E0 94 F0 FF F5 8F F3 4E 5C 82 09 F3 97
EB 01 52 EC D8 98 5C 4F 43 2E E7 9F F5 85 6D 15
B1 83 20 F8 5E D0 33 4F F0 C1 8F 65 77 3D 31 B2
FB A1 6E CA A6 D3 A2 35 1D 16 41 C3 89 86 98 78
8E 3E C1 64 01 79 05 21 47 AF 6A 6F 5B E1 4D 2B
2F CC 18 8E 42 DC 9A F8 3C D0 D0 57 04 FB 14 42
8C 54 9D A9 06 EB E7 48 E2 29 EF 7E FD F6 45 12
AC E4 BC 45 67 A3 9B 65 A1 0E ED 1A 84 AD 49 87
A2 77 3F 11 A7 1B D1 7F 25 36 6C 6F D3 DF 25 D0
FB

4.7 Outgoing condition Configuration

- ffff and make ship condition
- When pressing IN-STOP key by Service remote control, Red LED are blinked alternatively. And then Automatically turn off. (Must not AC power OFF during blinking)

4.8 Internal pressure

Confirm whether is normal or not when between power board's ac block and GND is impacted on 1.5kV(dc) or 2.2kV(dc) for one second

5. Adjustment Command

5.1. I2C(100K BPS)

5.2. COMMUNICATION START

START 6E A STOP 50Ms

Until ACK BIT goes LOW, Repeat it.

5.3. Command form

Command form use DDC2AB standard communication protocol.

START 6E A 50 A LEN A 30 A CMD A 00 A VAL A CS A STOP

- a. LEN : DATA BYTE number to send
- b. CMD : Command language that monitor executes.
- c. VAL : FOS DATA
- d. CS : Data's CHECKSUM that transmit
- e. DELAY : 50Ms
- f. A : Acknowledge

5.4. Adjustment Commands(LENGTH=84)

Adjustment Contents	CMD(hex)	ADR	VAL[HEX]	Description
FACTORY ON	E0	00	00	Factory mode on
FACTORY OFF	E2	00	00	Factory mode off
EEPROM ALL INIT.	E4	00	00	EEPROM All clear
EEPROM Read	E7	00	00	EEPROM Read
EEPROM Write	E8	00	data	EEPROM Write by some values
COLOR SAVE (R/G/B cutoff, Drive, Contrast, Bright)	EB	00	00	Color Save
H POSITION	20	00	00 – 64	They have different range each mode,
V POSITION	30	00	00 – 64	
CLOCK	90	00	00 – 64	FOS Adjustment
PHASE	92	00	00 – 64	
R DRIVE	16	00:cool 01:medium 02:warm	00 – 80	Drive adjustment
G DRIVE	18	00 :cool 01:medium 02:warm	00 – 80	
B DRIVE	1A	00:cool 01:medium 02:warm	00 – 80	
R CUTOFF	80	00	00 – 7F	Offset adjustment
G CUTOFF	82	00	00 – 7F	
B CUTOFF	84	00	00 – 7F	
BRIGHT	10	00	00 – 3F	Bright adjustment
CONTRAST	12	00	00 - 64	Luminance adjustment
AUTO_COLOR_ADJUST	F1	00	02	Auto COLOR Adjustment
CHANGE_COLOR_TEMP	F2	00	0,1,2,3	0: Cool 1: Medium 2: Warm 3: User
White Pattern	F3	00	00,FF	00: White pattern off FF: White pattern on
AUTO_INPUTCHANGE	F4	00	0,10,20,30,40,60,90	0 : TV 10 : DTV 20 : SCART1 30 : SCART2 40 : Component 60 : RGB 90 : HDMI

5.5. EEPROM DATA READ

(1) Signal TABLE

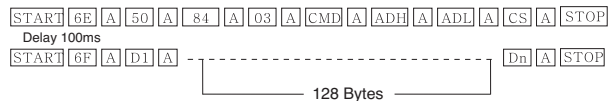

(2) Command Set

Adjustment item	CMD(hex)	ADH(hex)	ADL(hex)	Details
EEPROM READ	E7	A0	0	0-Page 0~7F Read
			80	0-Page 80~FF Read
		A2	0	1-Page 0~7F Read
			80	1-Page 80~FF Read
		A4	0	2-Page 0~7F Read
			80	2-Page 80~FF Read
		A6	0	3-Page 0~7F Read
			80	3-Page 80~FF Read

* Purpose : To read(84h) the appointment Address of EEPROM by 128(80h)-byte

5.6. E²PROM Data Write

(1) Signal TABLE

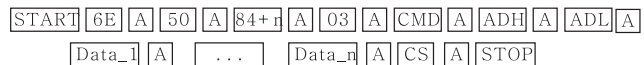

LEN : 84h+Bytes

CMD : 8Eh

ADH : E²PROM Slave Address(A0,A2,A4,A6,A8), Not 00h
(Reserved by Buffer To EEPROM)

ADL : E²PROM Sub Address(00~FF)

Data : Write data

(2) Command Set

Adjustment item	CMD(hex)	LEN	Remark
EEPROM WRITE	E8	94	16-Byte Write
		84+n	n-byte Write

* Purpose

- EDID write : 16-byte by 16-byte, 8 order (128-byte) write(TO "00 – 7F" of "EEPROM Page A4").
- FOS Default write : 16-mode data (HFh, HFI, VF, STD, HP, VP, Clk, ClkPh, PhFine) write
- Random Data write : write the appointment Address of E²PROM.

5.7. VRAM Read

- Send CMD(70h) to read Video RAM value from MICOM and save its value to 128-Bytes Buffer(Common Buffer for the use of EDID)

- Delay 500ms (Time to Wait and Read Video RAM from

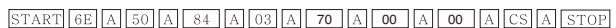

MICOM)

- Be transmitted the contents of MICOM's 128-bytes Buffer to PC. (128th Data is the CheckSum of 127-bytes data : That's OK if the value of adding 128-bytes Data is Zero)



TROUBLESHOOTING

1. TV/CATV doesn't display

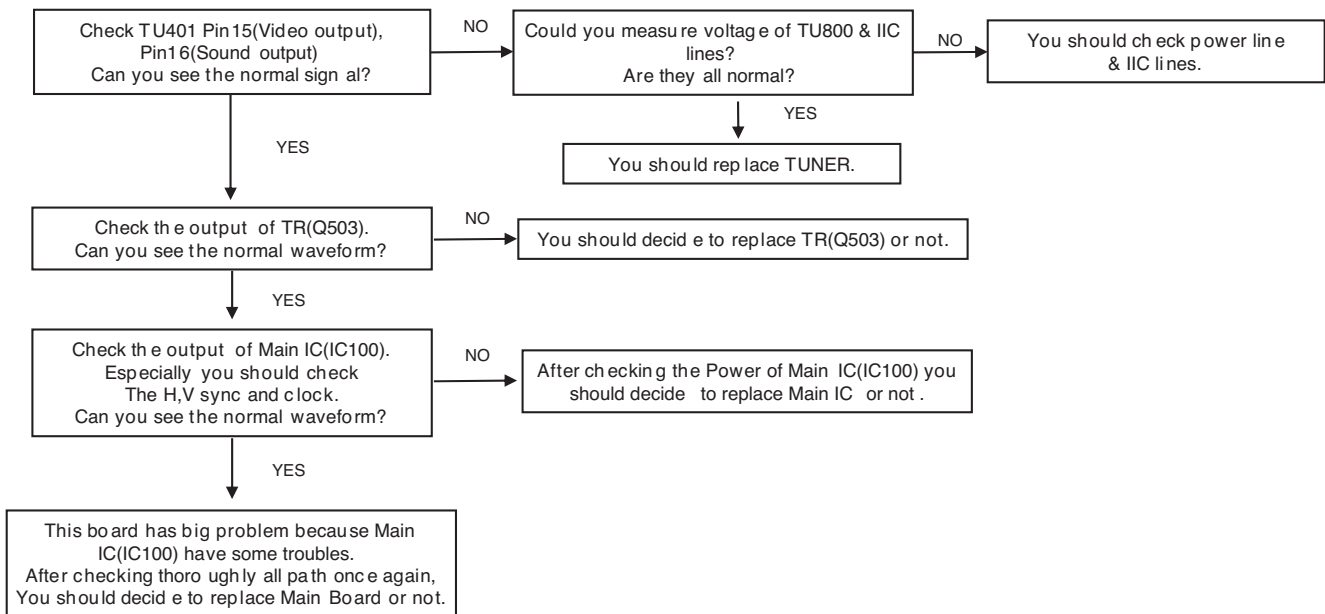

2. DTV doesn't display

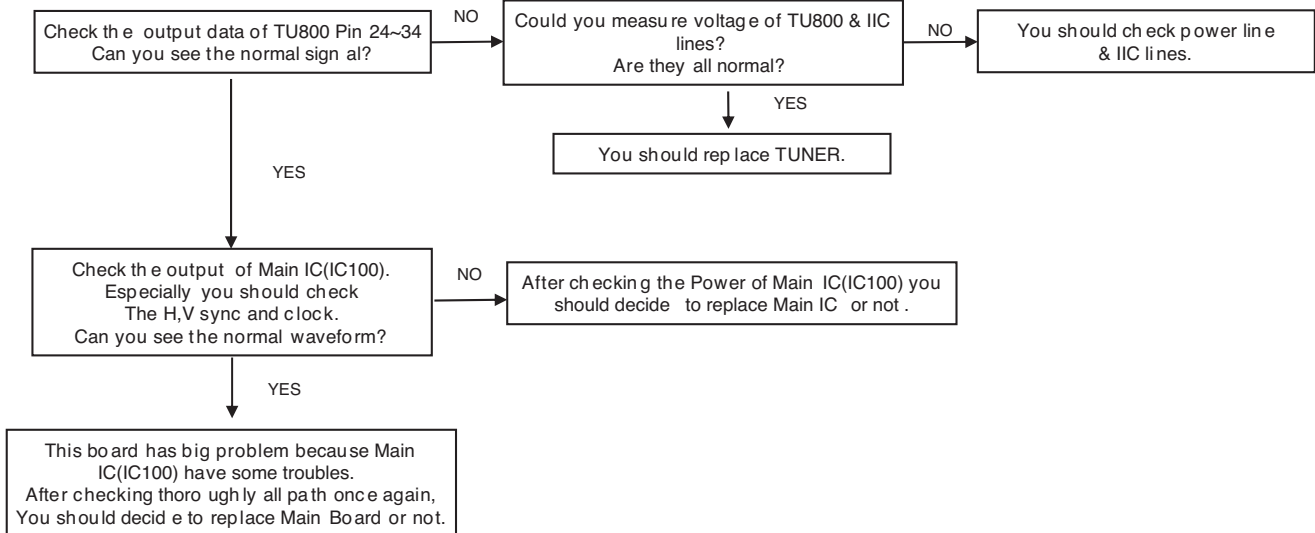

3. AV 1/2/3 doesn't display

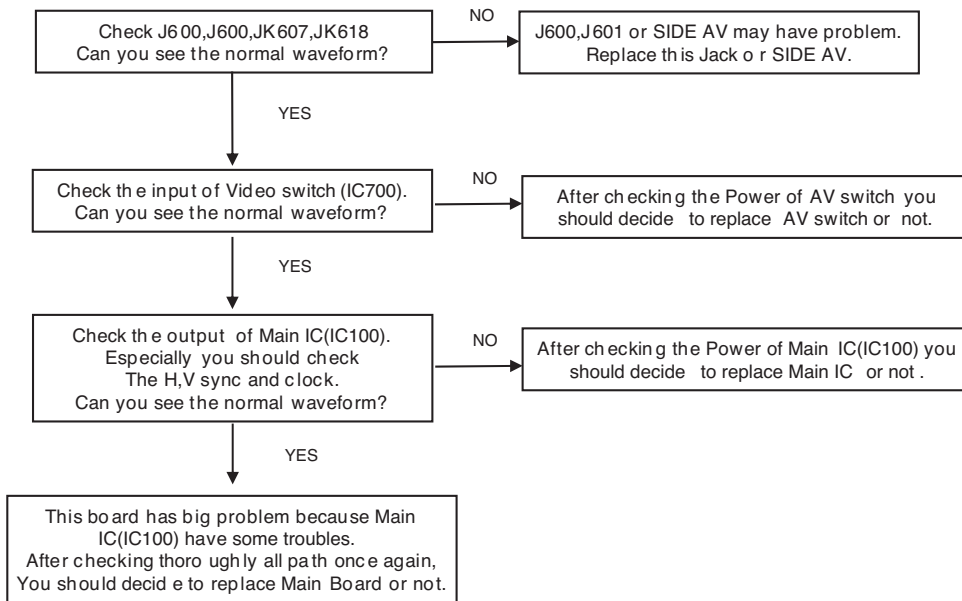

4. Component doesn't display

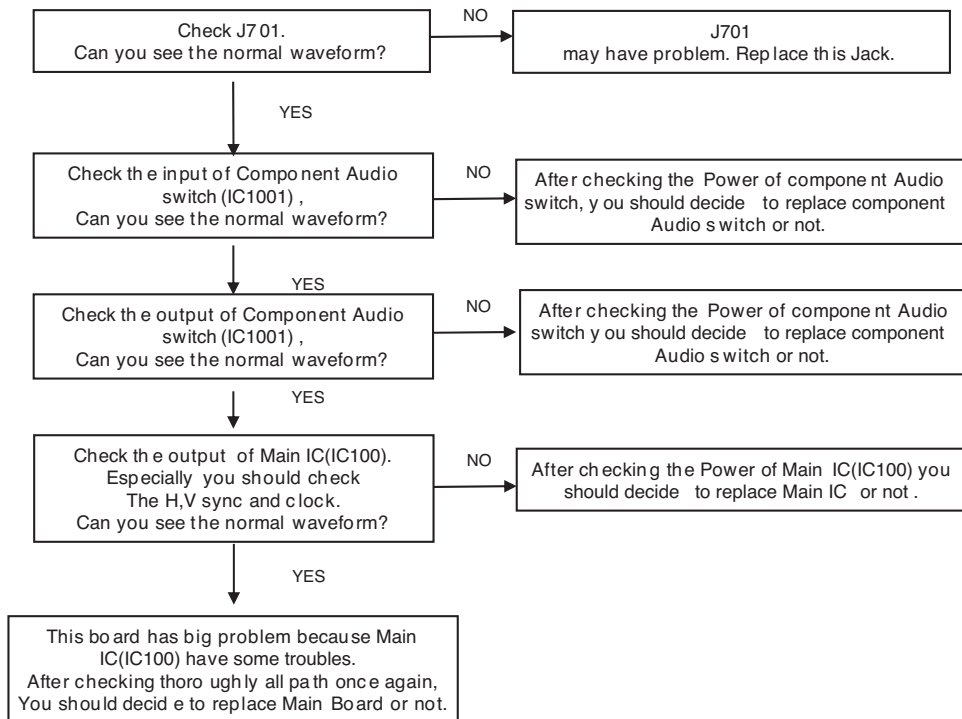

5. RGB PC doesn't display

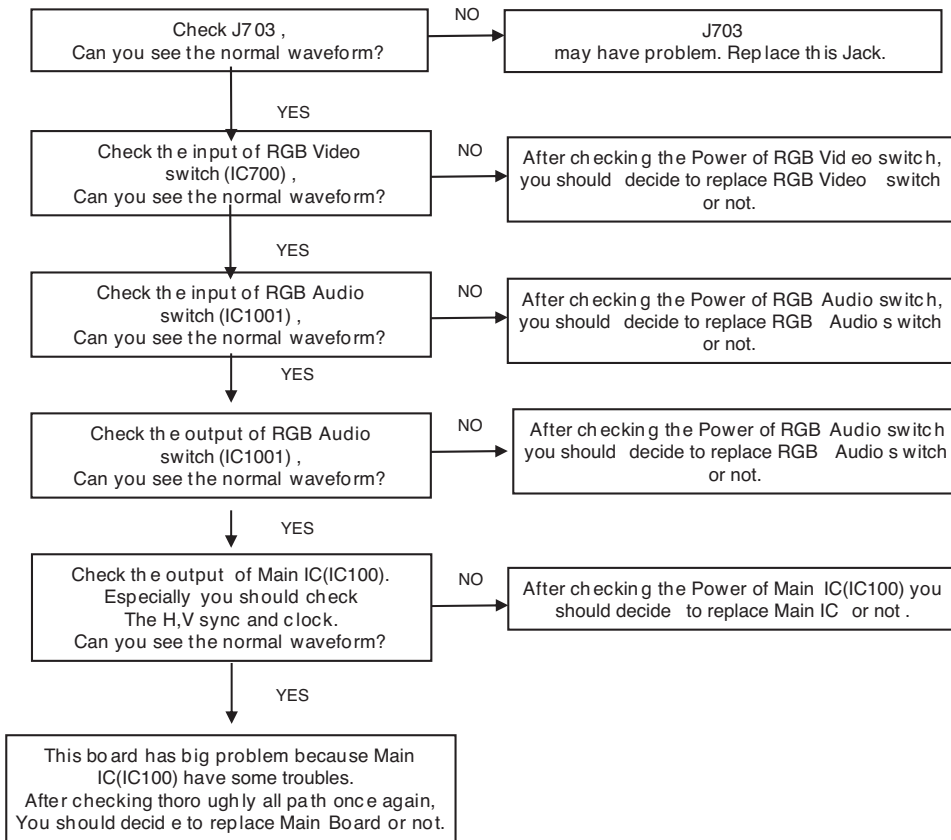

6. HDMI doesn't display

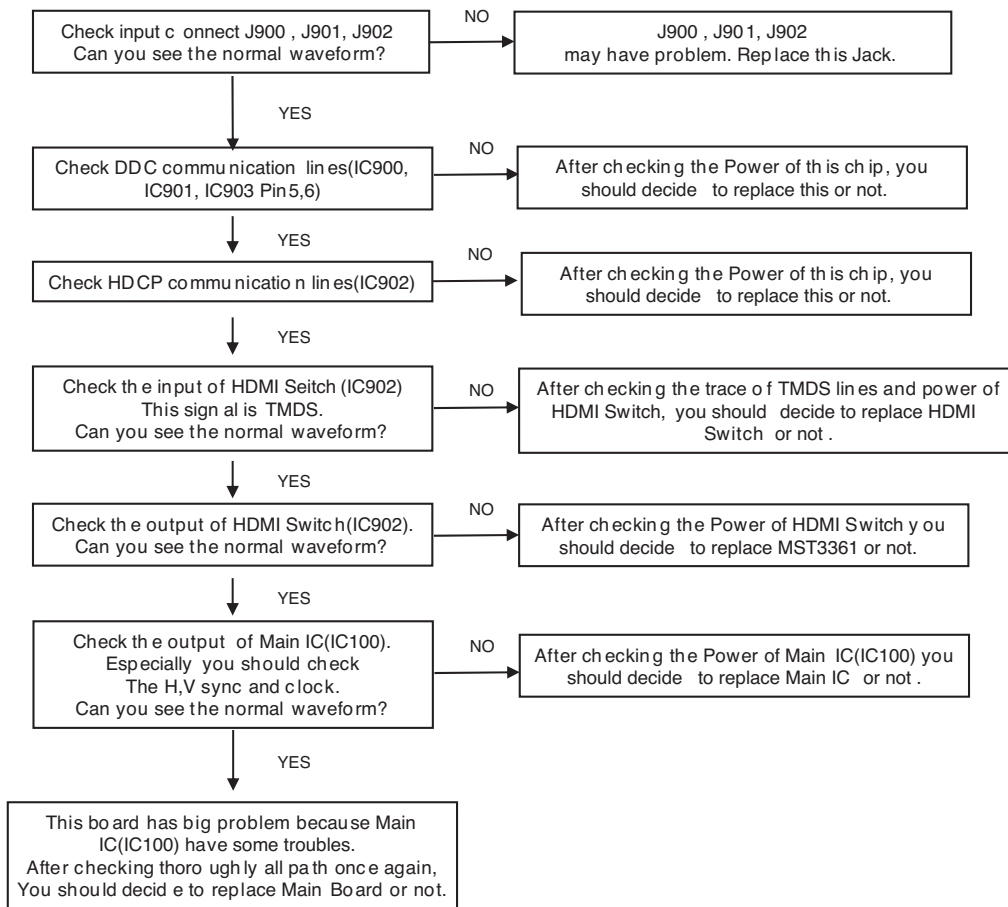

BLOCK DIAGRAM

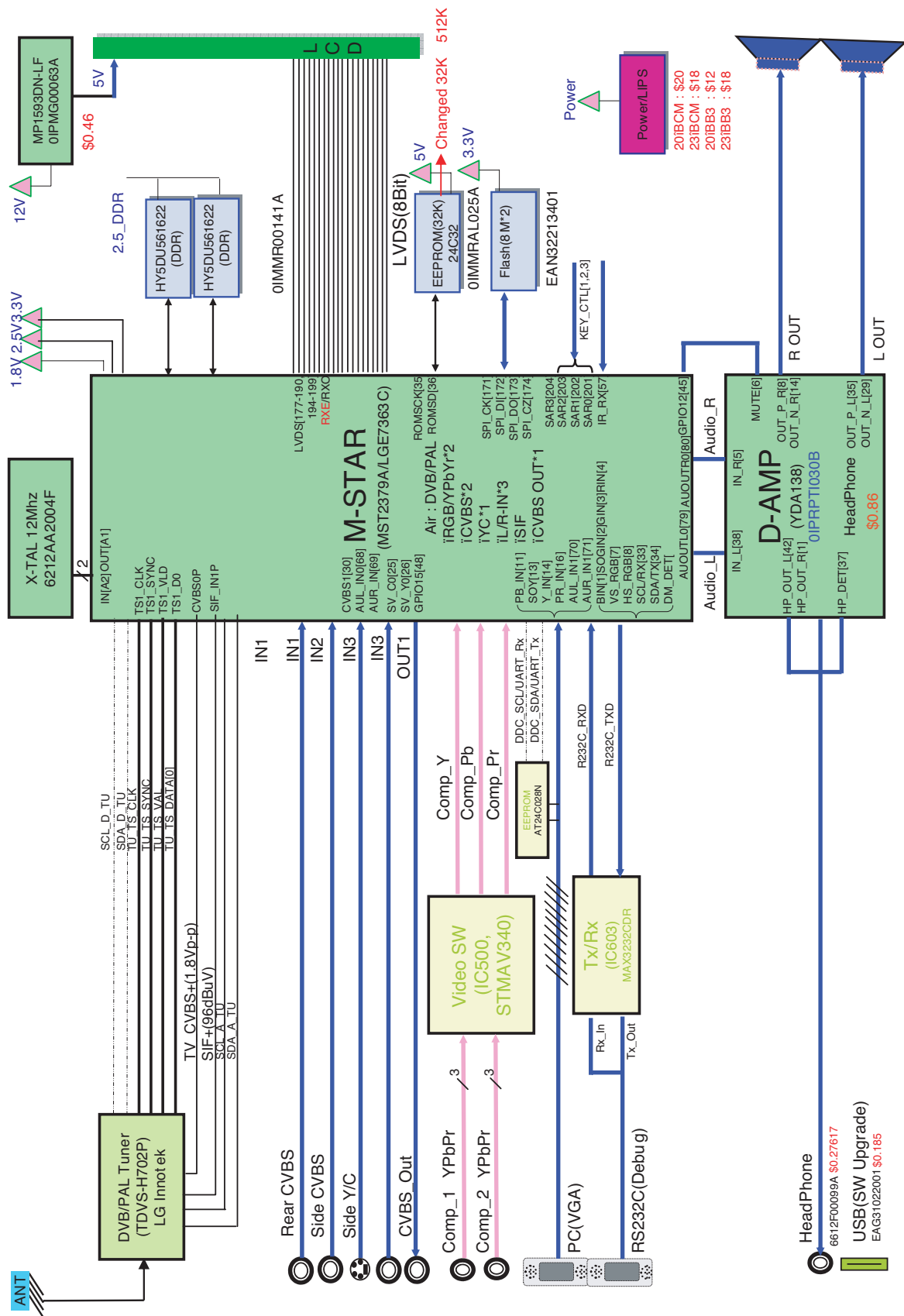

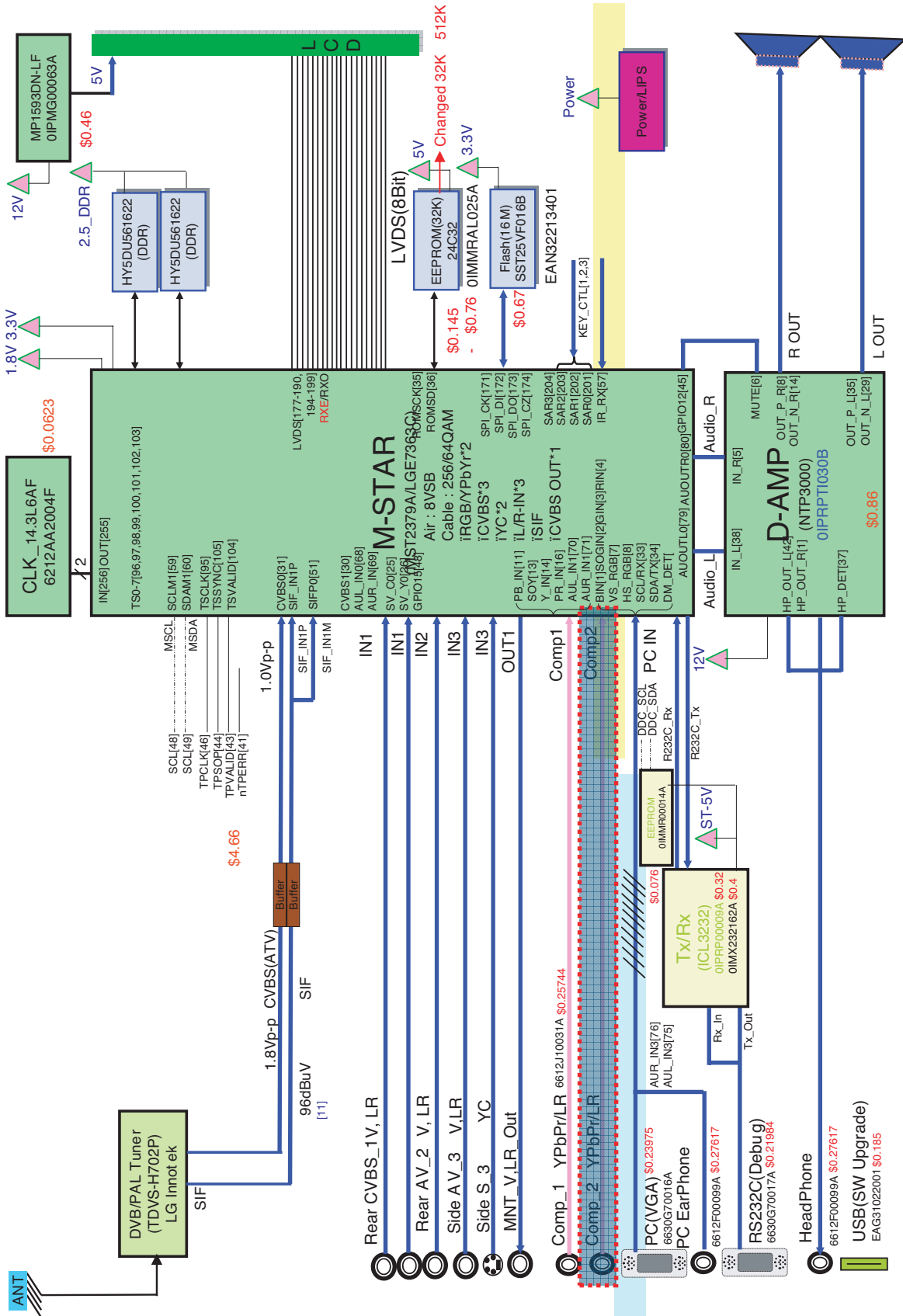

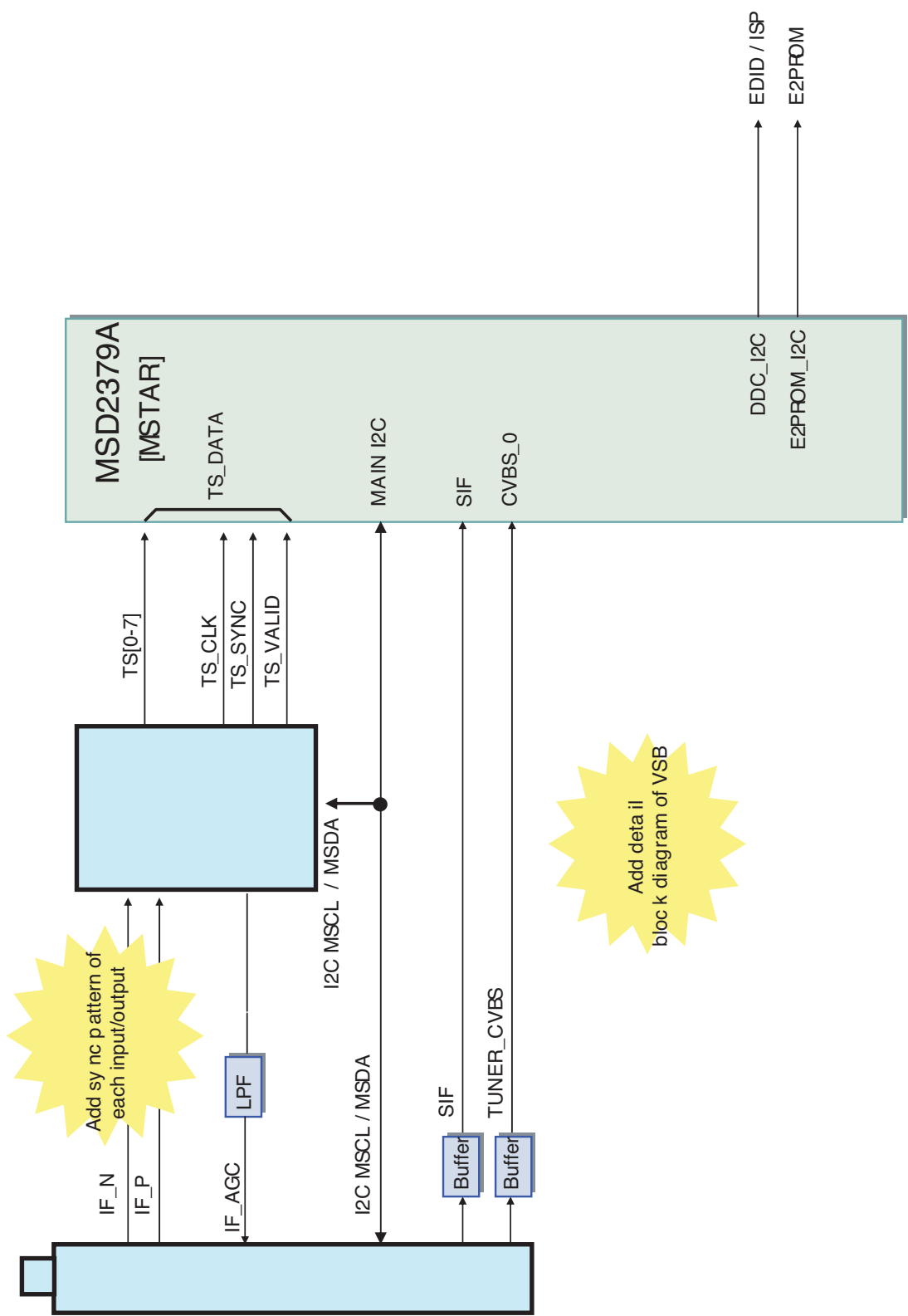

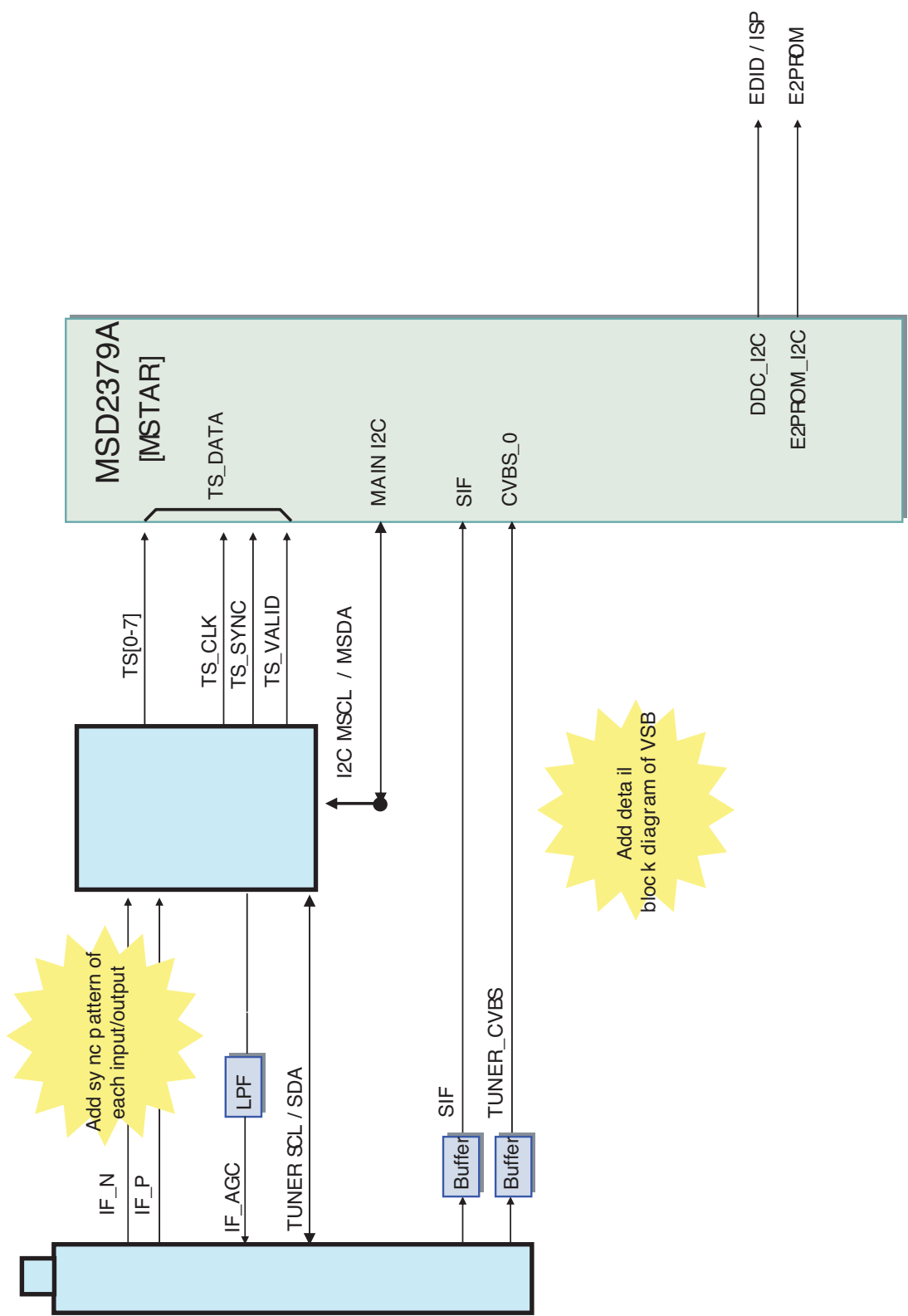

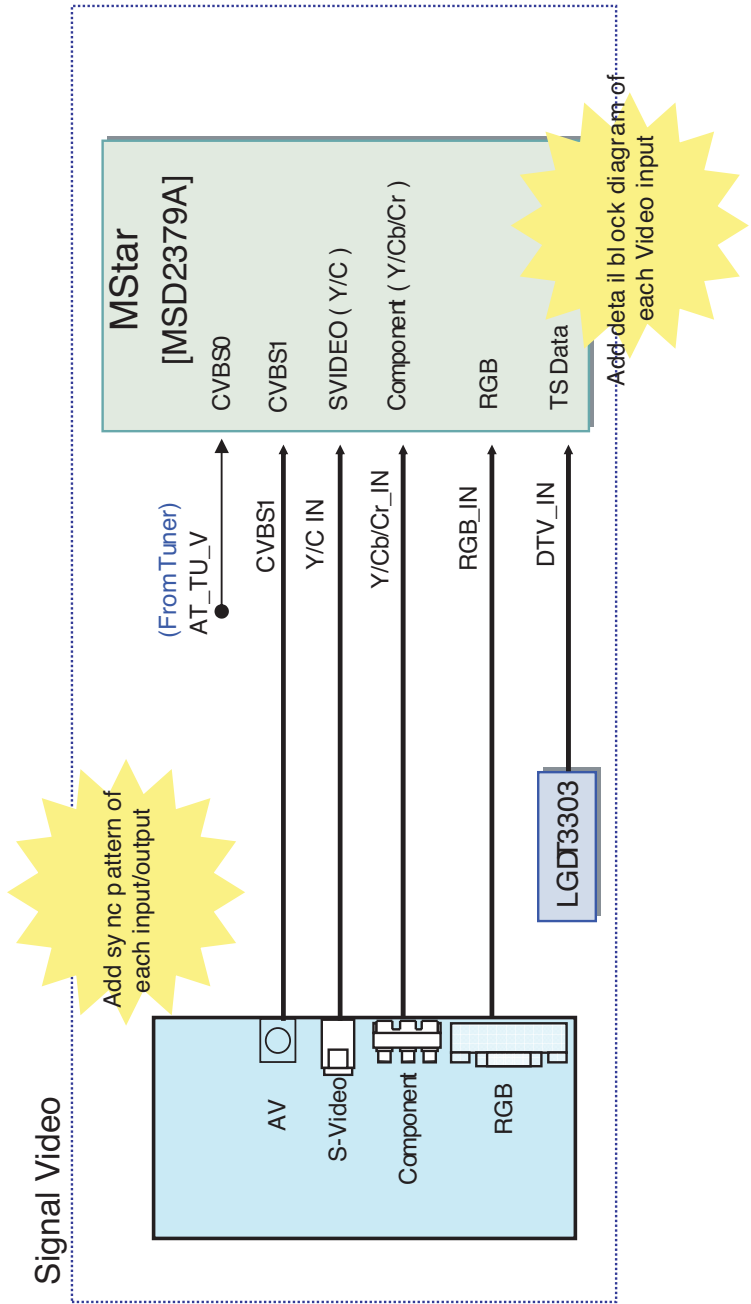

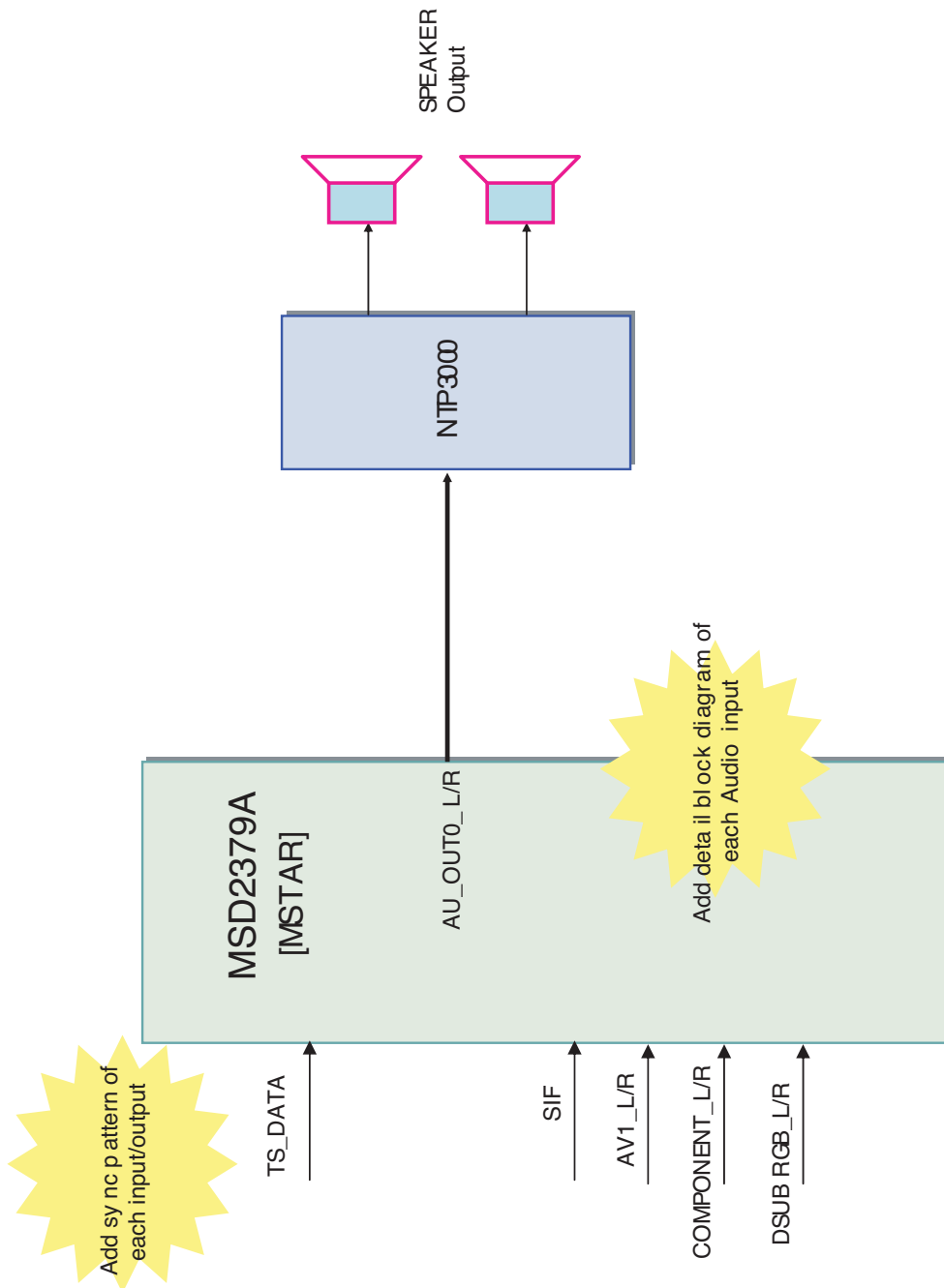

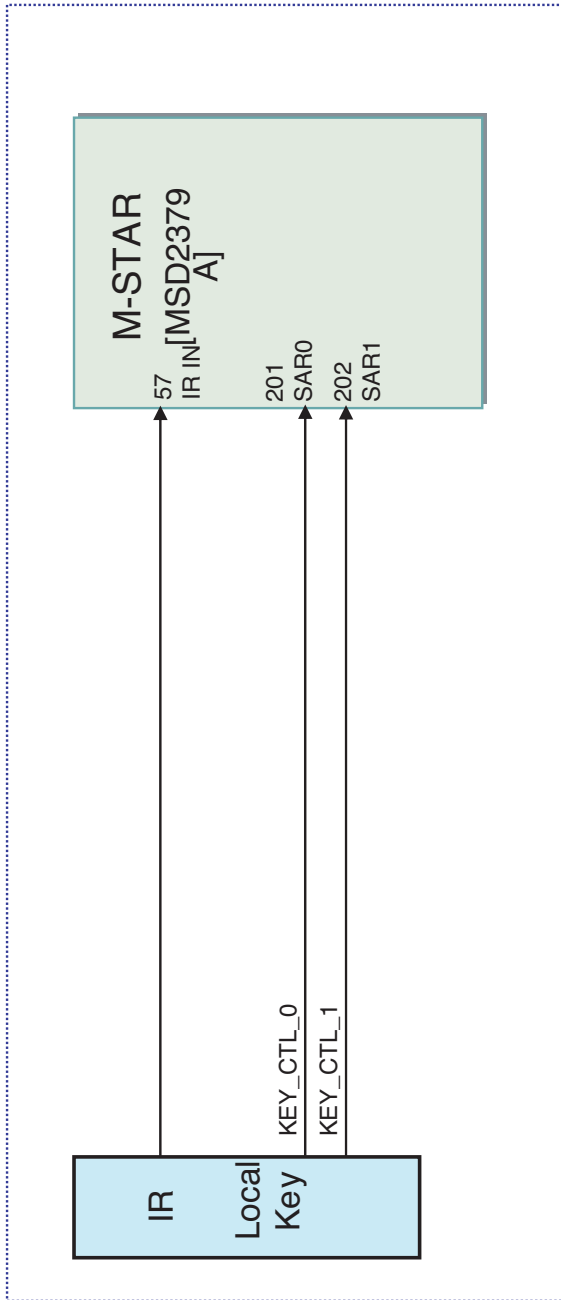

SAR is low speed 6-Bits ADC input and also for GP I/O function use.

The I/O tolerance is 3.3V maximum for use.

The application of AVDD key, the conversion voltage for full scale of MSD1226L is 1.8V.

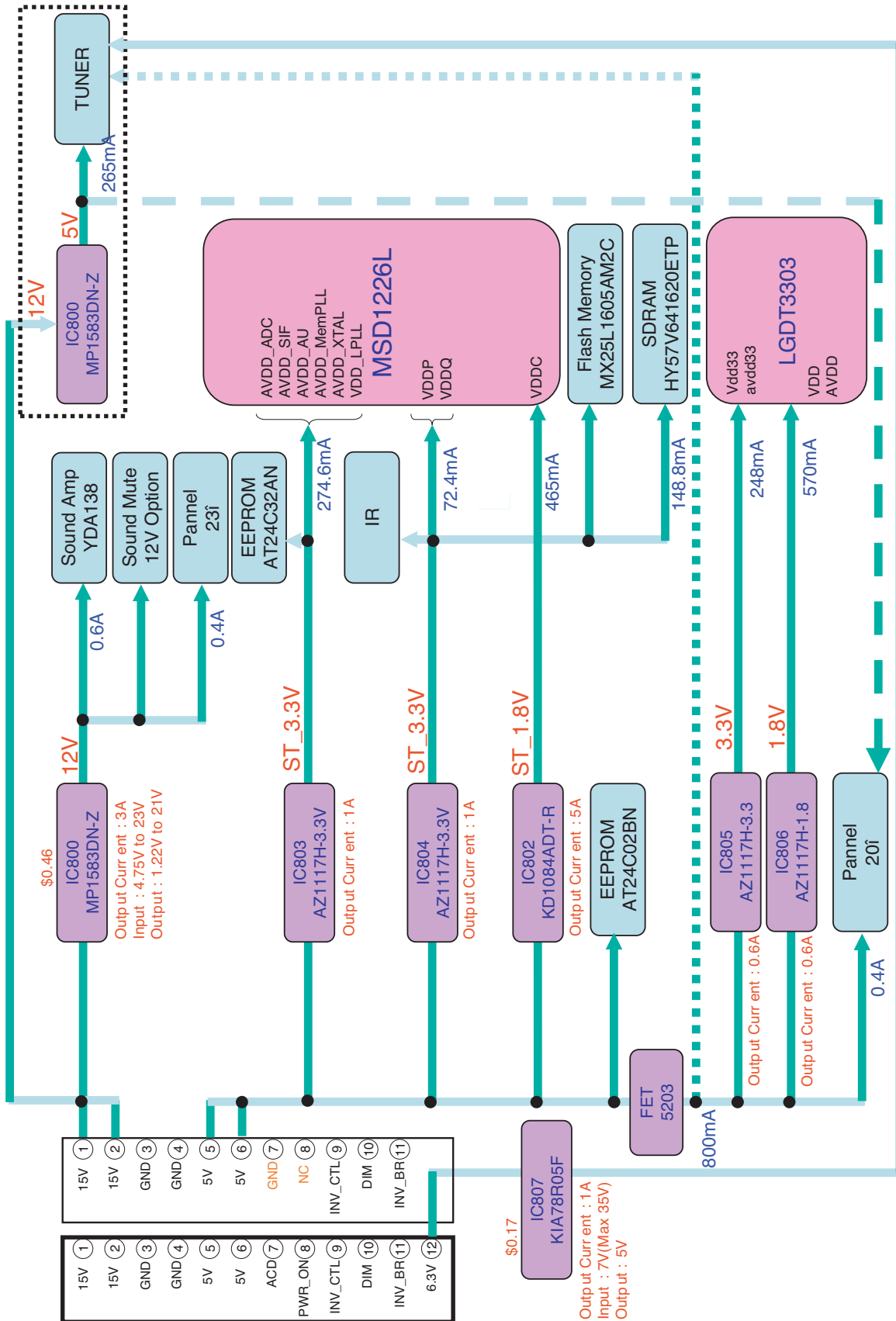

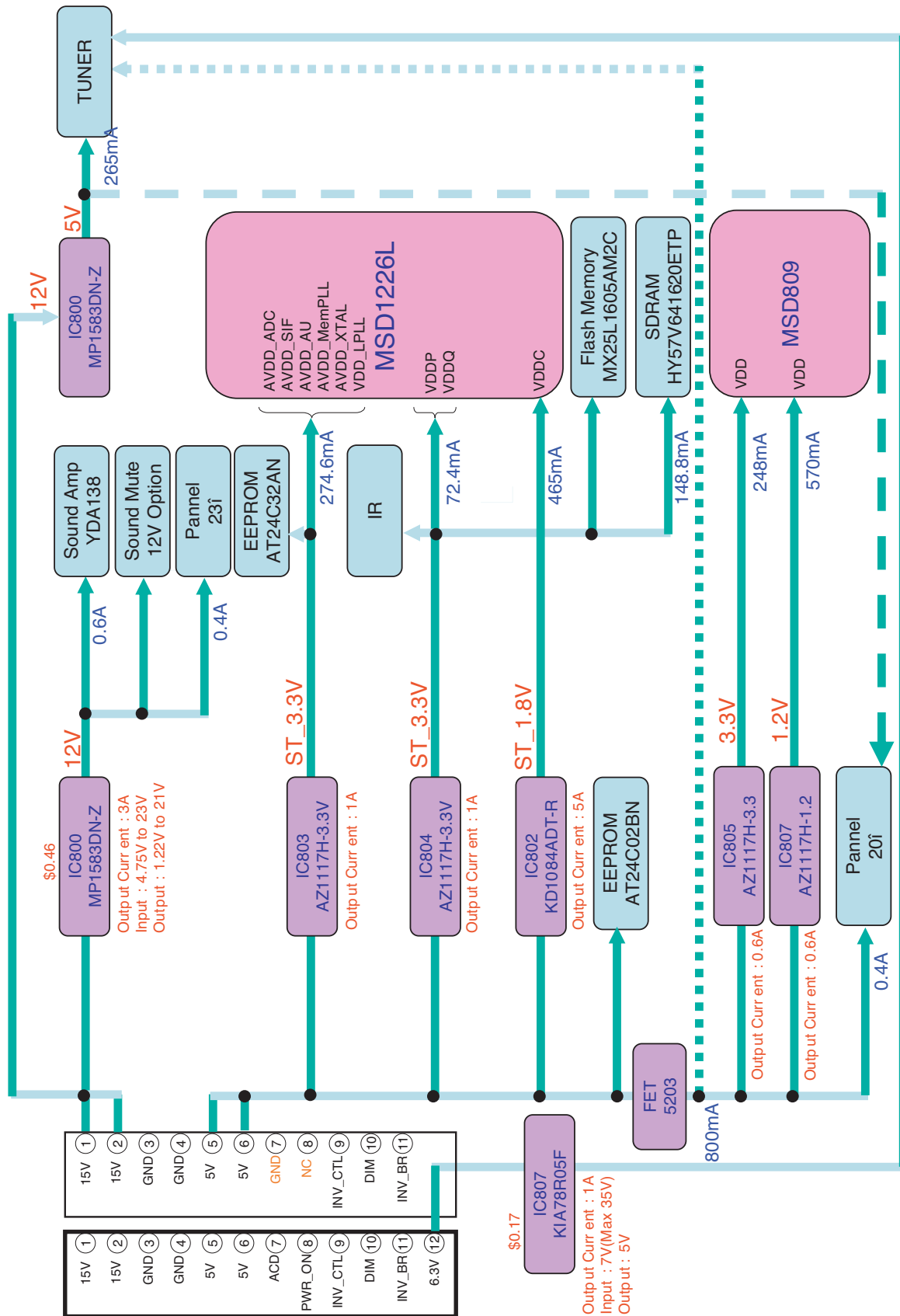

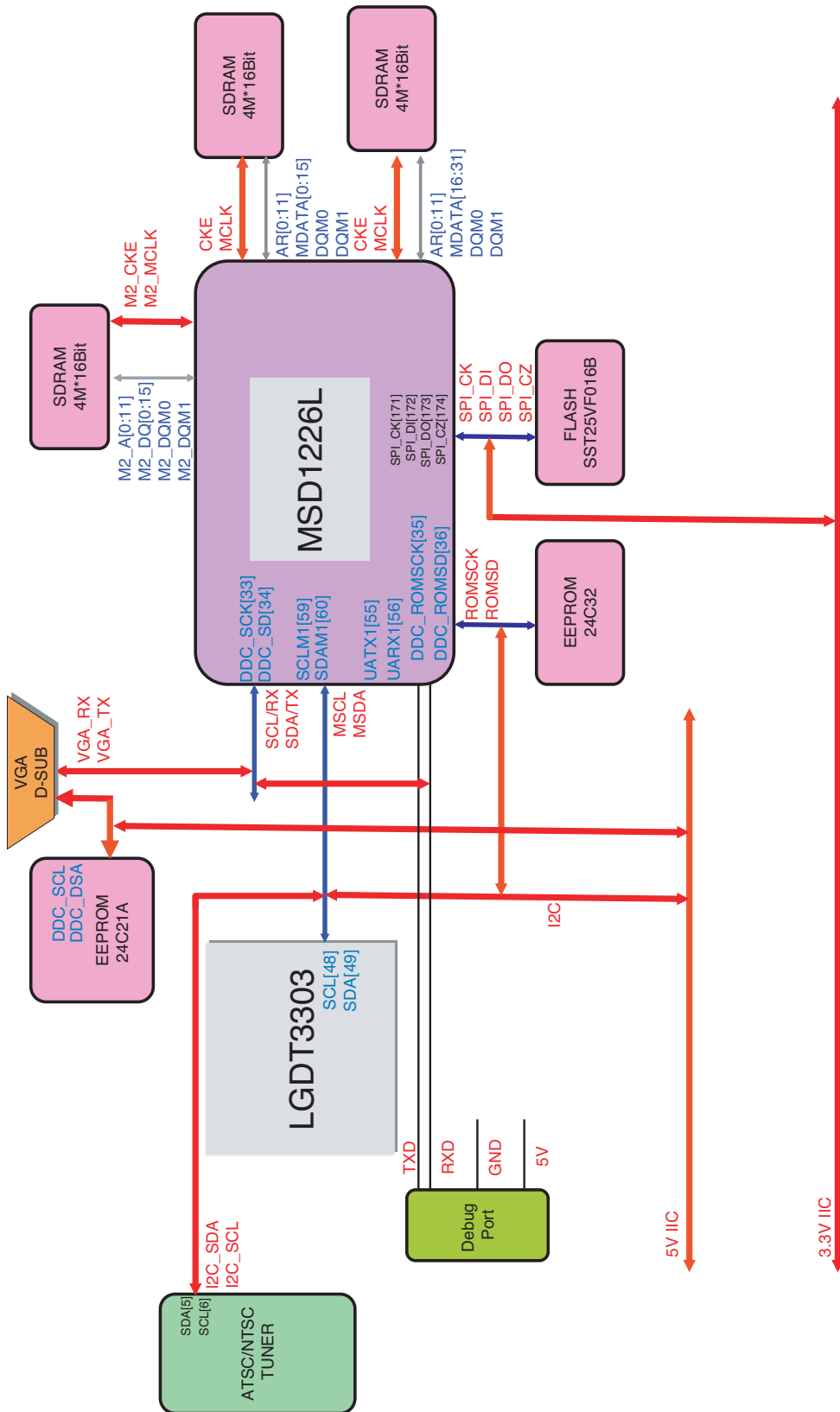

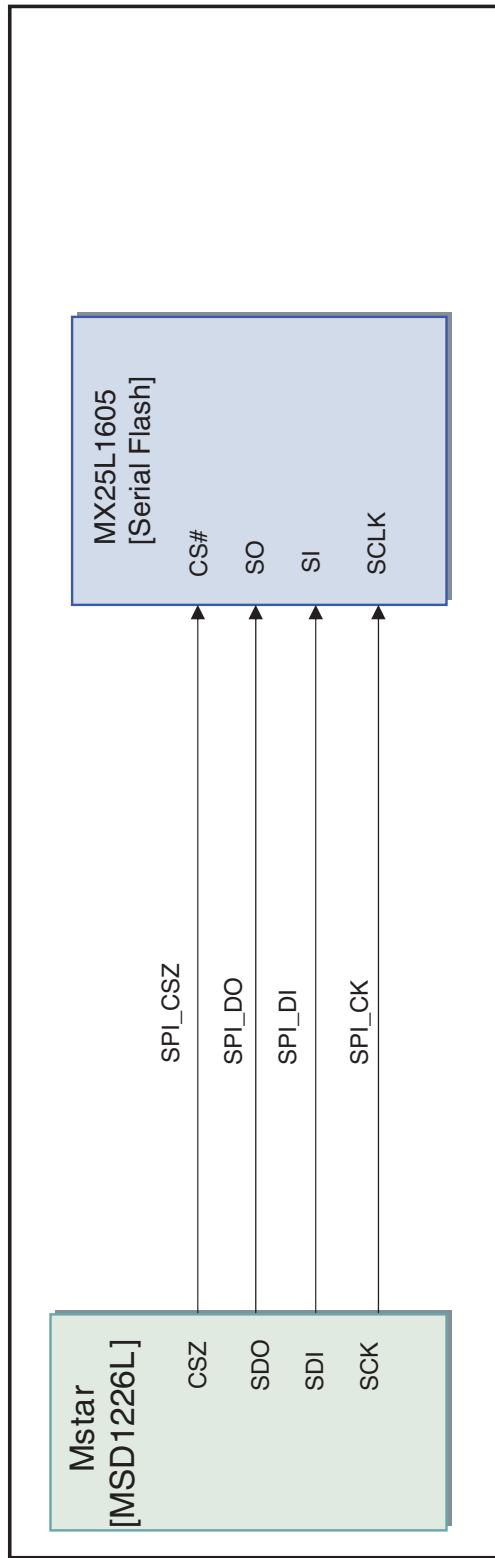
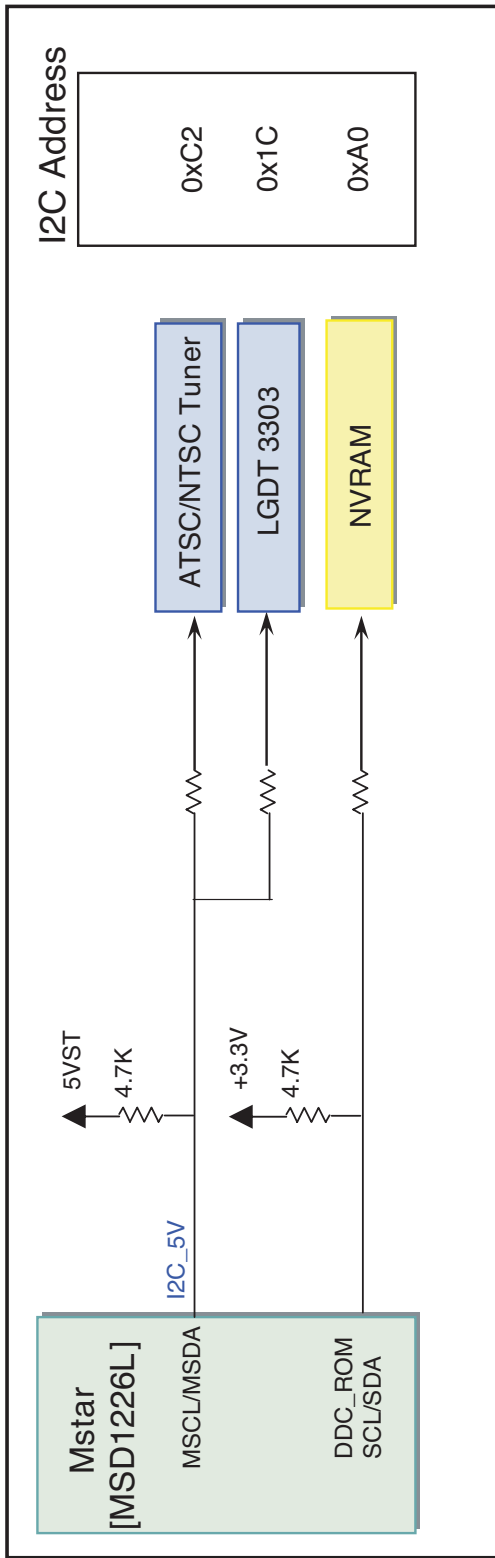

MEMO

EXPLODED VIEW

IMPORTANT SAFETY NOTICE

Many electrical and mechanical parts in this chassis have special safety-related characteristics. These parts are identified by Δ in the Schematic Diagram and EXPLODED VIEW.

It is essential that these special safety parts should be replaced with the same components as recommended in this manual to prevent X-RADIATION, Shock, Fire, or other Hazards.

Do not modify the original design without permission of manufacturer.

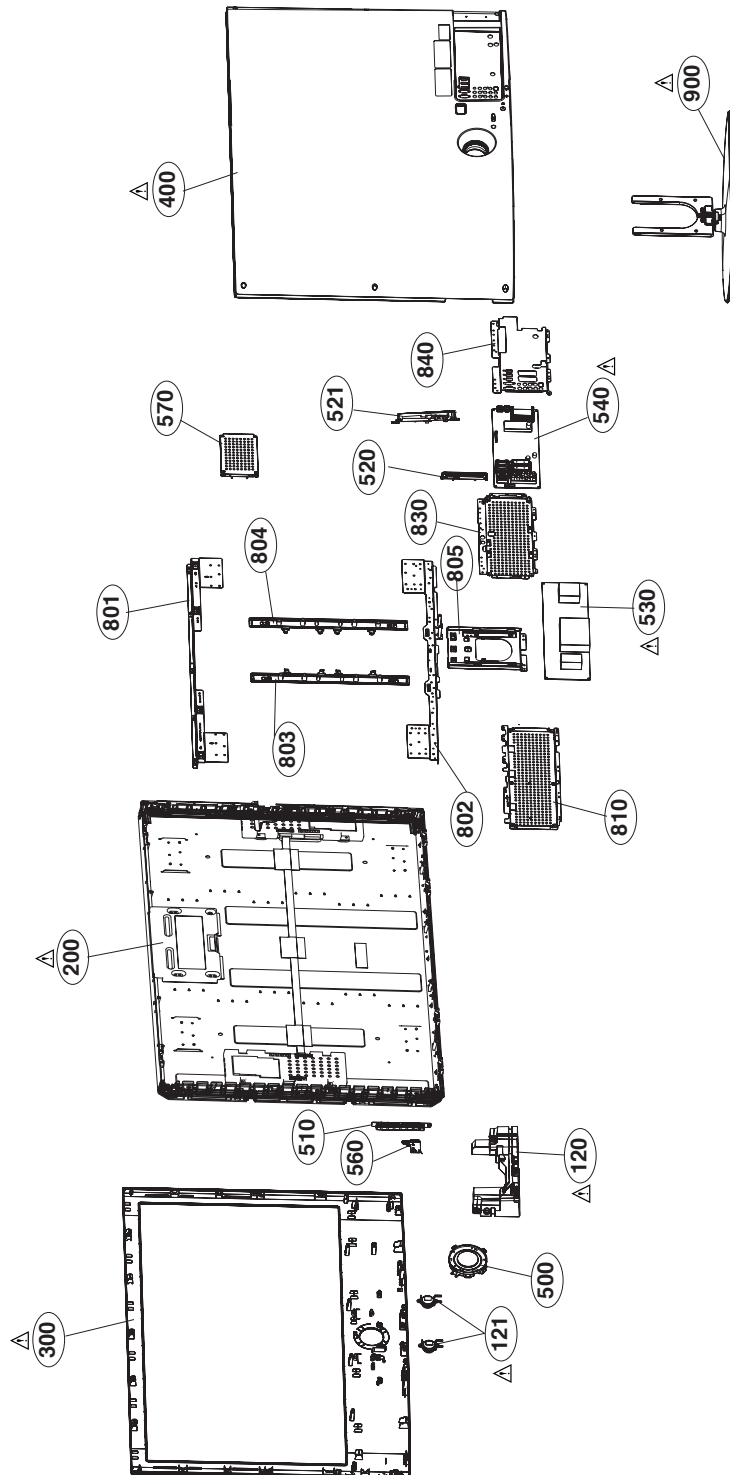

SCHEMATIC DIAGRAM

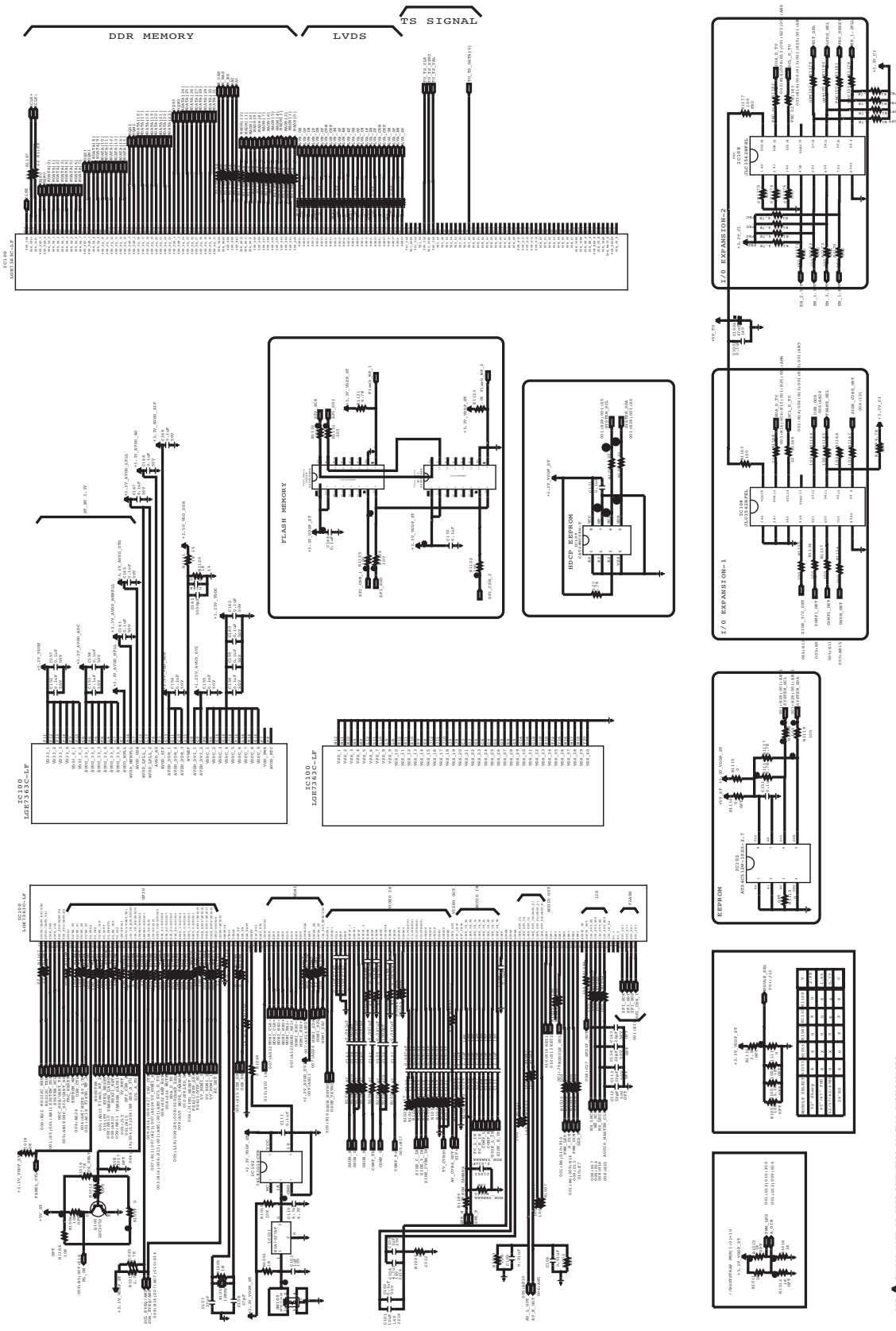

THE SYMBOL MARK OF THIS SCHEMATIC DIAGRAM INCORPORATES SPECIAL FEATURES IMPORTANT FOR PROTECTION FROM X-RADIATION, FIRE AND ELECTRICAL SHOCK HAZARDS. WHEN SERVICING IT IS ESSENTIAL THAT ONLY MANUFACTURER SPECIFIED PARTS BE USED FOR THE CRITICAL COMPONENTS IN THE SYMBOL MARK OF THE SCHEMATIC.

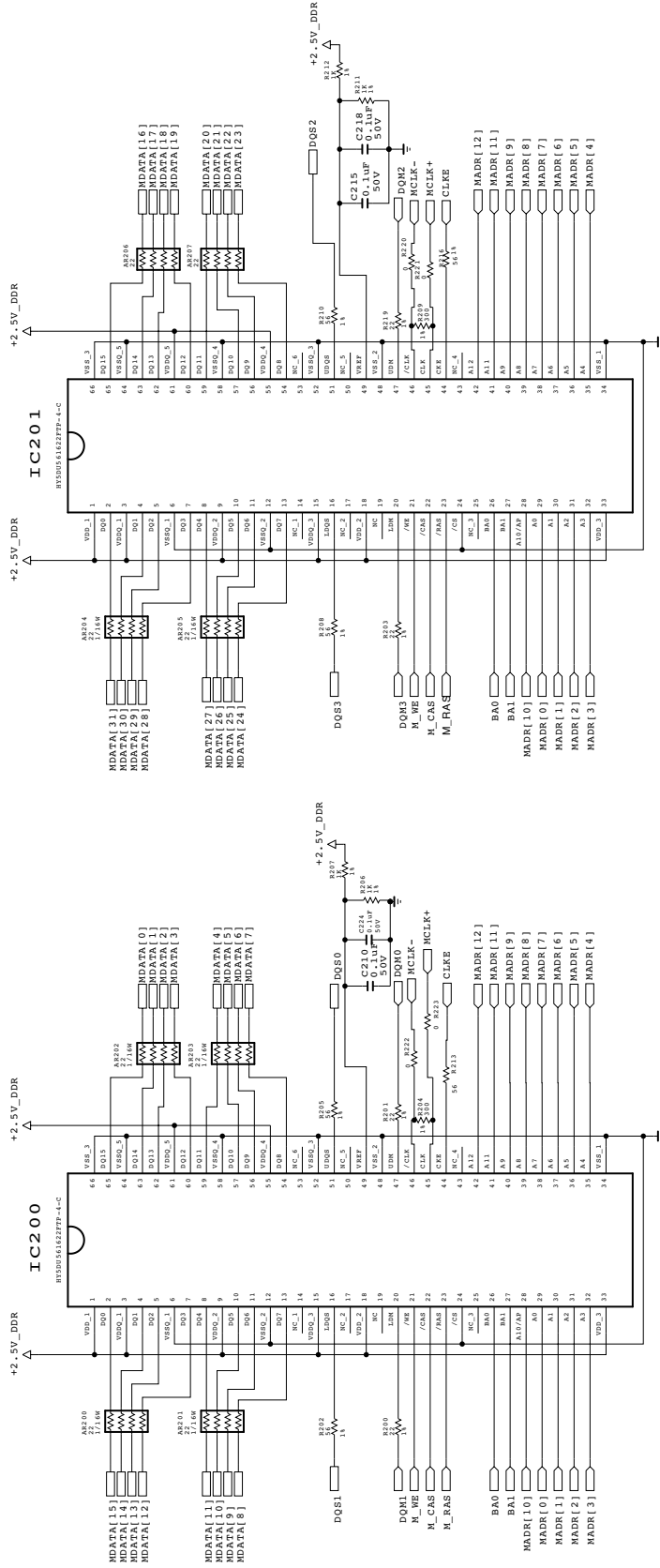
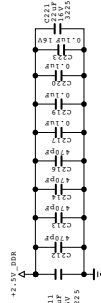

1 milL = 0.0254 mm
 20 milL = 0.508 mm
 40 milL = 1.016 mm

ADDRESS TOTAL LENGTH < 3000 milL (76.2mm)
 DDR1 & DDR2 different length range = +/- 25 milL (max +/- 50 milL)



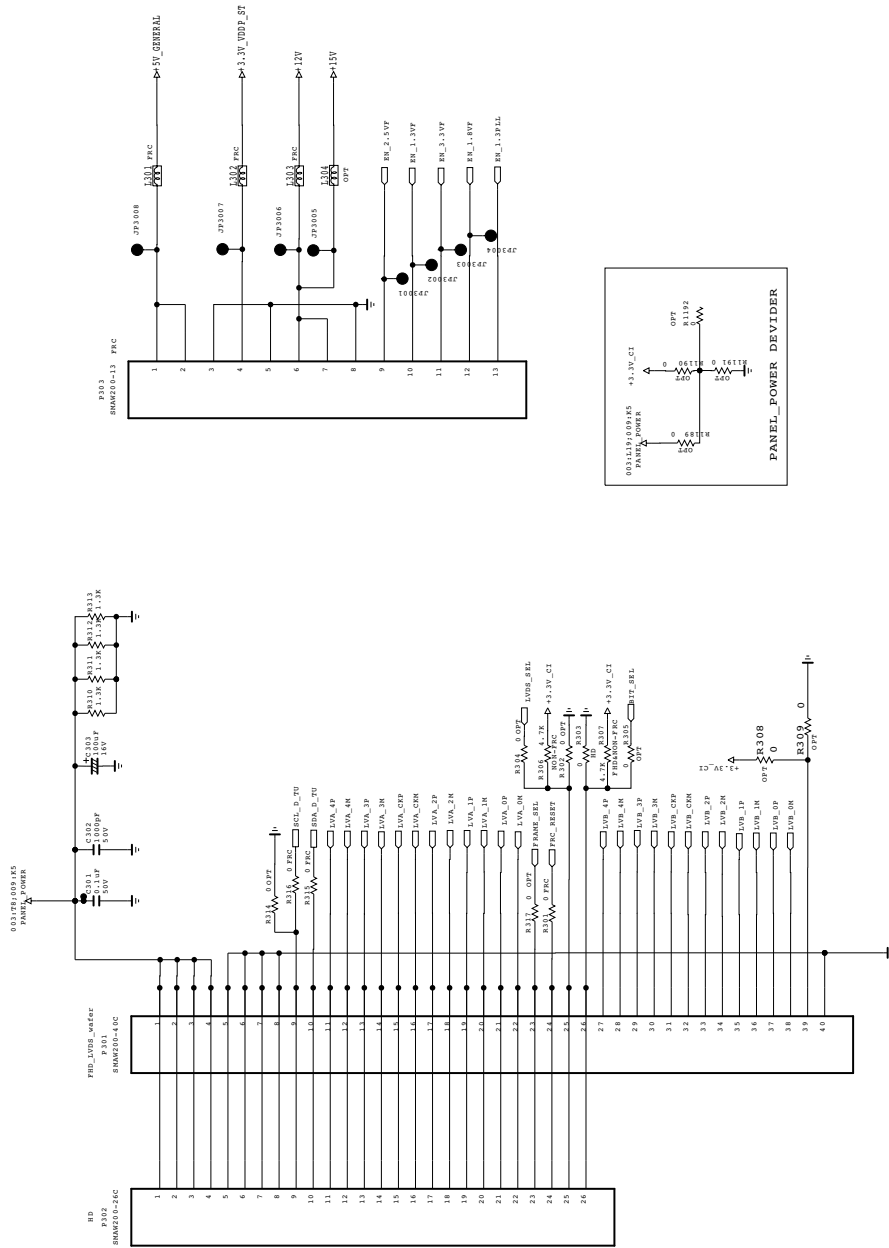

THE Δ SYMBOL MARK OF THIS SCHEMATIC DIAGRAM INCORPORATES SPECIAL FEATURES IMPORTANT FOR PROTECTION FROM X-RADIATION, FILRE AND ELECTRICAL SHOCK HAZARDS, WHEN SERVICING IF IS ESSENTIAL THAT ONLY MANUFACTURES SPECIFIED PARTS BE USED FOR THE CRITICAL COMPONENTS IN THE Δ SYMBOL MARK OF THE SCHEMATIC.



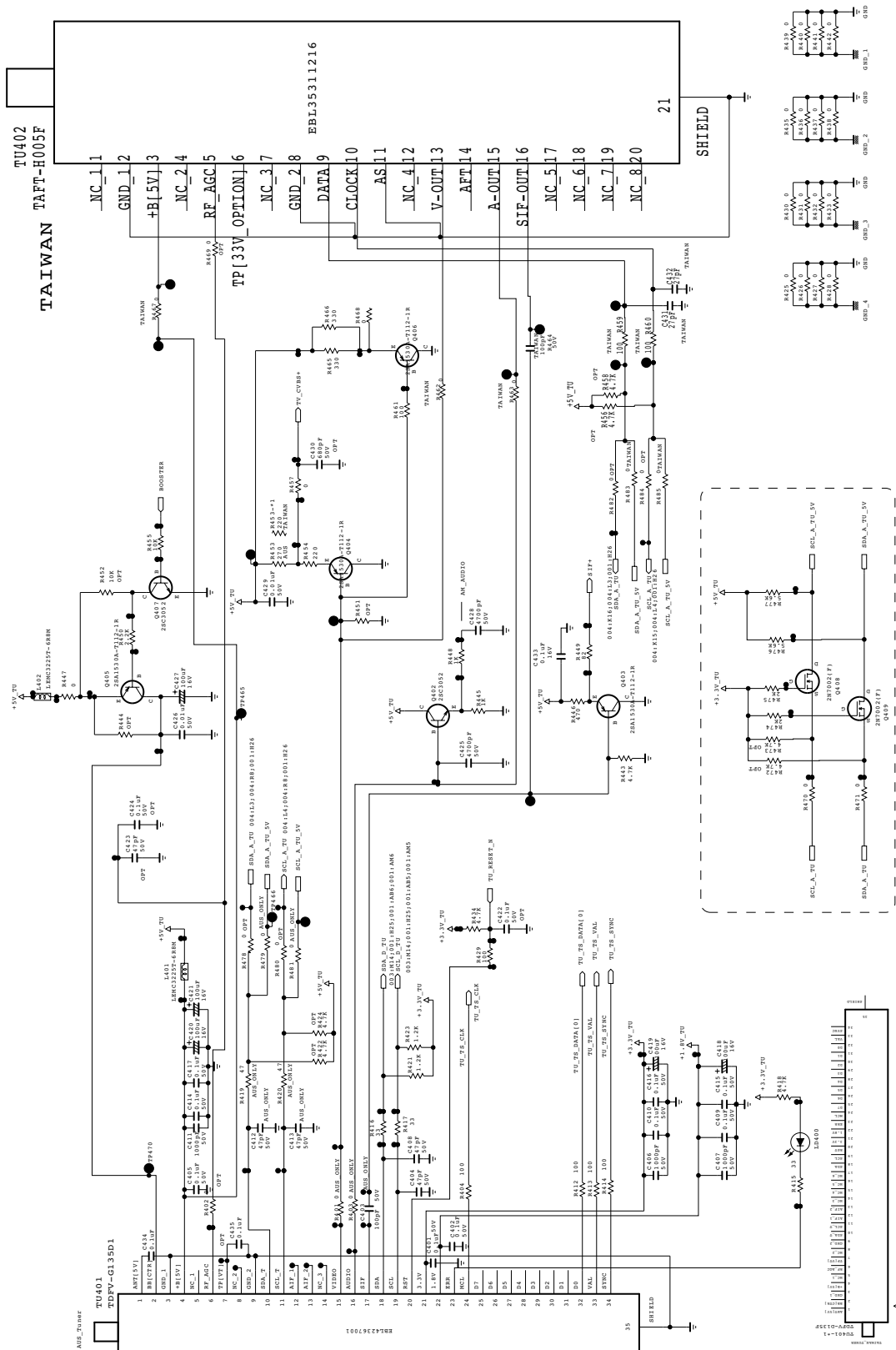

THE  SYMBOL MARK OF THIS SCHEMATIC DIAGRAM INCORPORATES SPECIAL FEATURES IMPORTANT FOR PROTECTION FROM X-RADIATION, FLAME AND ELECTRICAL SHOCK HAZARDS. WHEN SERVICING, IT IS ESSENTIAL THAT ONLY MANUFACTURERS SPECIFIED PARTS BE USED FOR THE CRITICAL COMPONENTS IN THE  SYMBOL MARK OF THE SCHEMATIC.

MODEL:6274



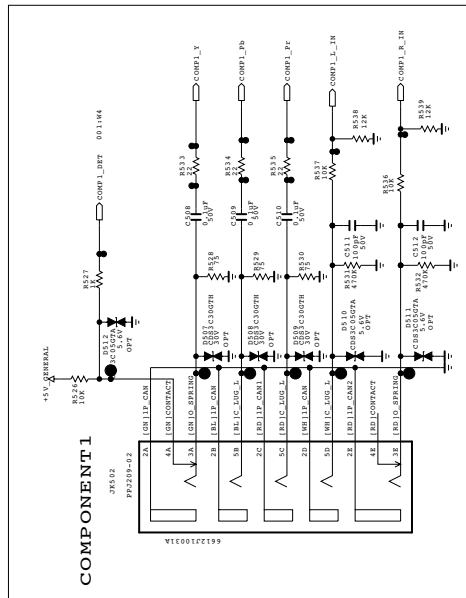
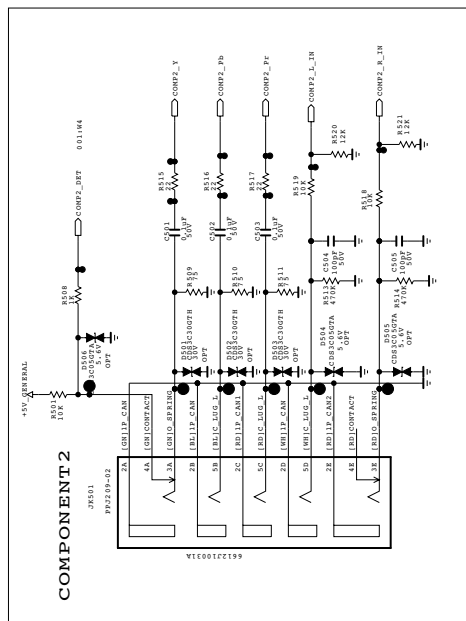
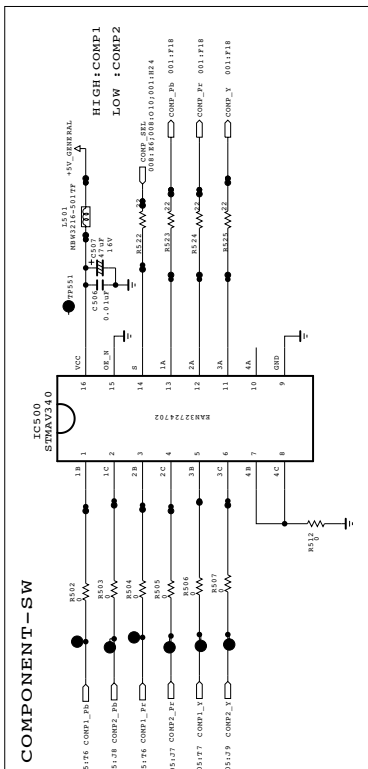
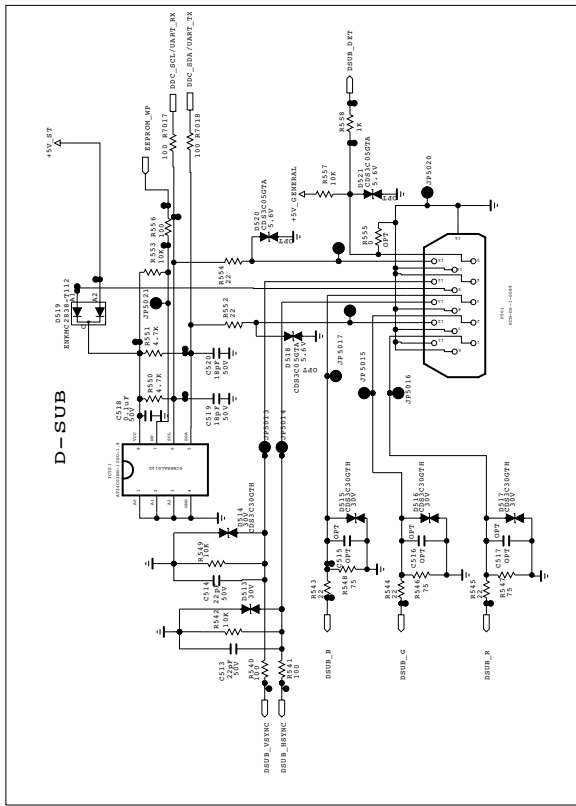

THE  SYMBOL MARK OF THIS SCHEMATIC DIAGRAM INCORPORATES SPECIAL FEATURES IMPORTANT FOR PROTECTION FROM X-RADIATION, FIRE AND ELECTRICAL SHOCK HAZARDS, WHEN SERVICING IT IS ESSENTIAL THAT ONLY MANUFACTURERS SPECIFIED PARTS BE USED FOR THE CRITICAL COMPONENTS IN THE  SYMBOL MARK OF THE SCHEMATIC.

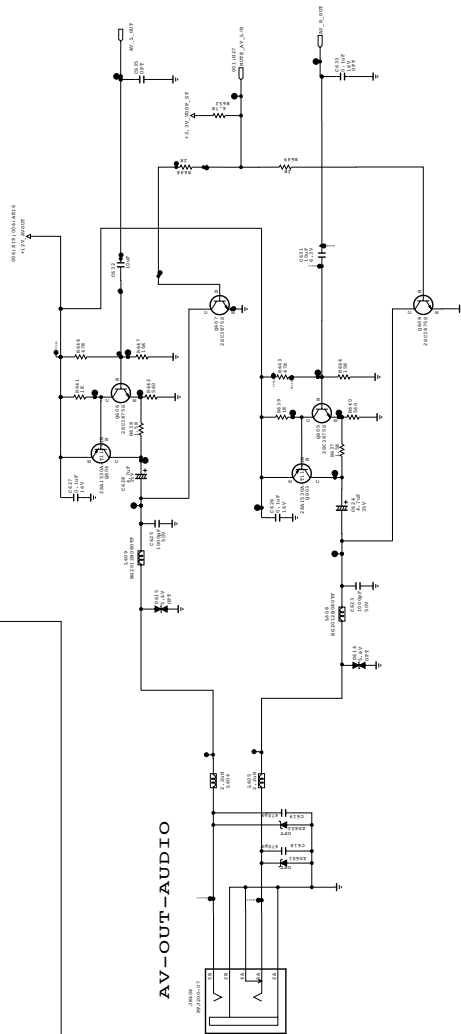
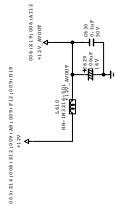
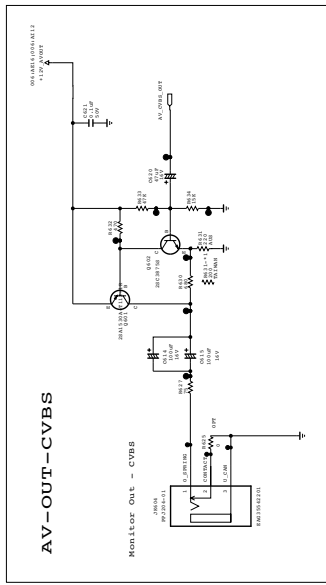
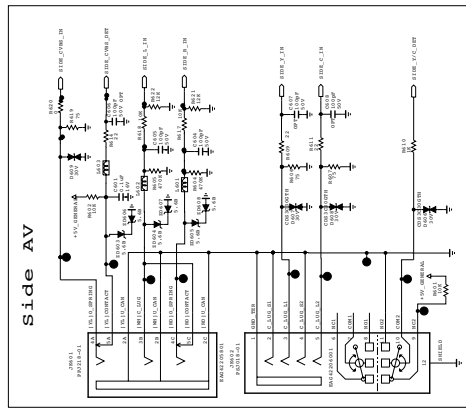
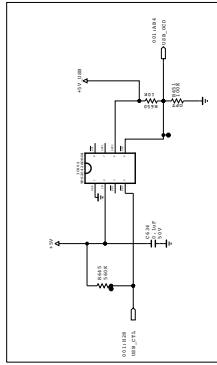
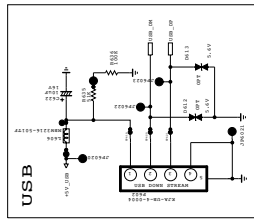
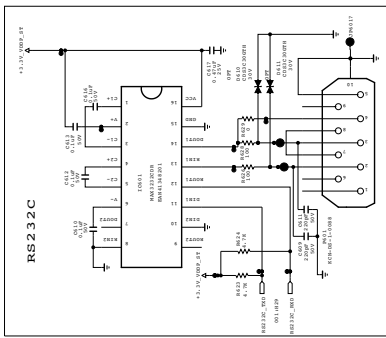
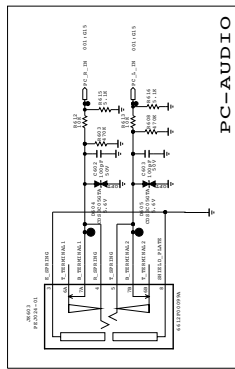

THE  SYMBOL MARK OF THIS SCHEMATIC DIAGRAM INCORPORATES SPECIAL FEATURES IMPORTANT FOR PROTECTION FROM X-RADIATION, FIRE AND ELECTRICAL SHOCK HAZARDS, WHEN SERVICING IT IS ESSENTIAL THAT ONLY MANUFACTURERS SPECIFIED PARTS BE USED FOR THE CRITICAL COMPONENTS IN THE  SYMBOL MARK OF THE SCHEMATIC.



THE  SYMBOL MARK OF THIS SCHEMATIC DIAGRAM INCORPORATES THE INFORMATION OF THE PARTS LIST AND THE PARTS LIST FILE AND ELECTRICAL SHOCK HAZARDS - WHEN SERVICING IT IS ESSENTIAL THAT ONLY MANUFACTURERS SPECIFIED PARTS BE USED FOR THE CRITICAL COMPONENTS IN THE  SYMBOL MARK OF THE SCHEMATIC.

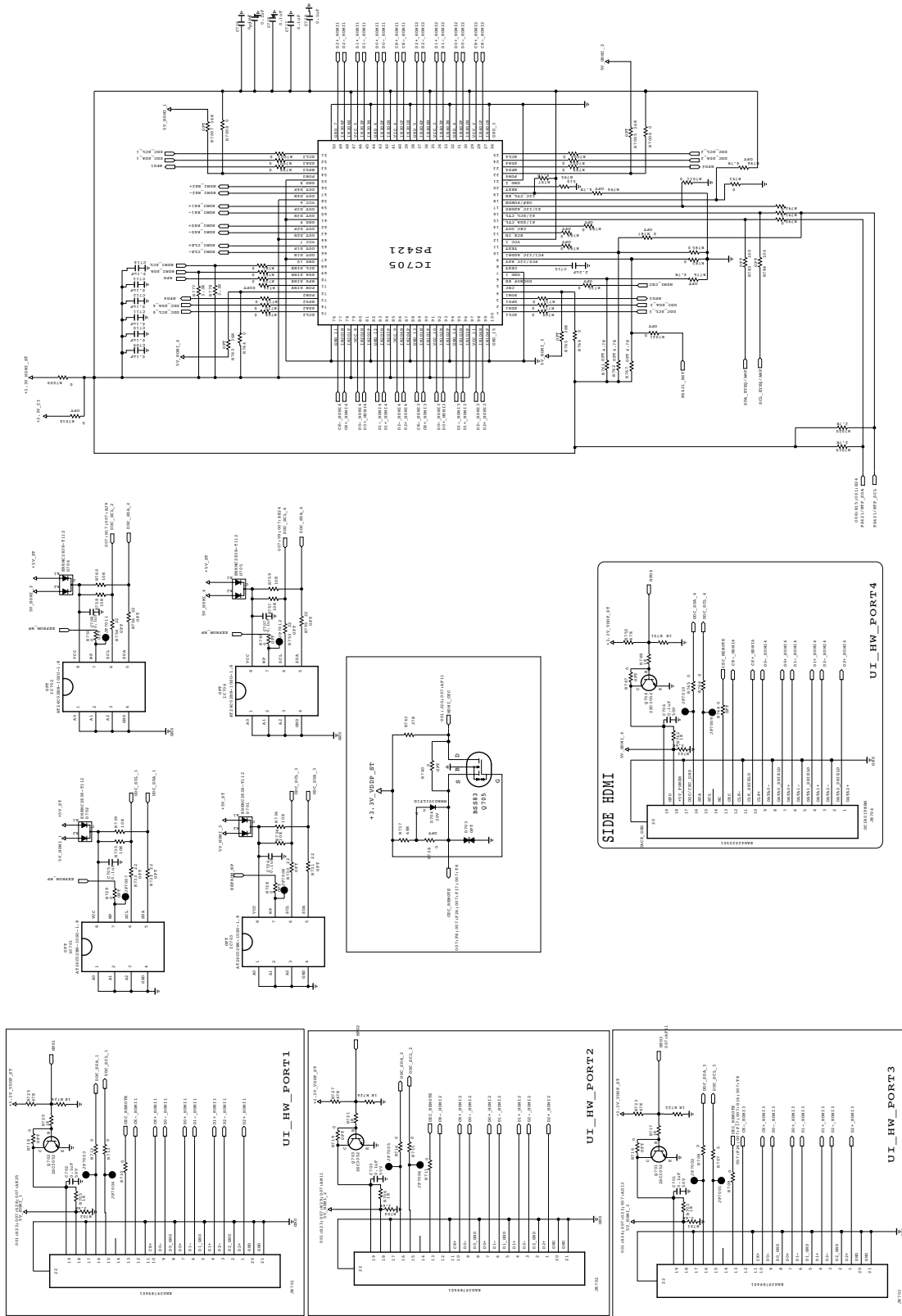

THE SWING MARK OF THIS SCHEMATIC DIAGRAM INCORPORATES THE SWING MARK OF THE REGISTERED TRADEMARK OF LG ELECTRONICS, LTD. THIS TRADEMARK IS A REGISTERED TRADEMARK OF LG ELECTRONICS, LTD. IN THE U.S. AND OTHER COUNTRIES. IT IS ESSENTIAL THAT ONLY MANUFACTURERS SPECIFIED PARTS BE USED FOR THE CRITICAL COMPONENTS IN THE SWING MARK OF THE SCHEMATIC.

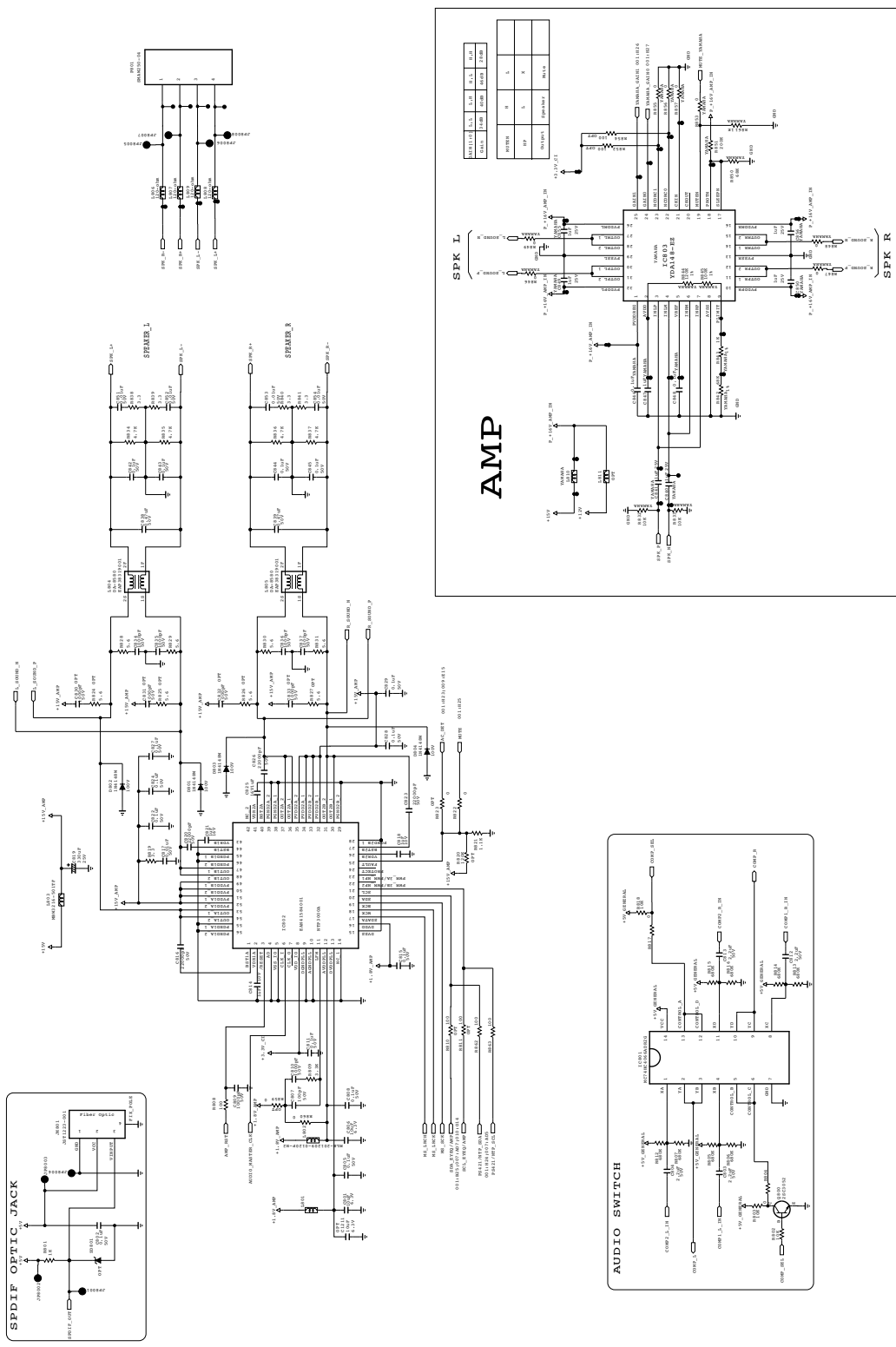

THE Δ SYMBOL MARK OF THIS SCHEMATIC DIAGRAM INCORPORATES SPECIAL FEATURES IMPORTANT FOR PROTECTION FROM X-RADIATION, FIRE AND ELECTRICAL SHOCK HAZARDS. WHEN SERVICING IT IS ESSENTIAL THAT ONLY MANUFACTURERS SPECIFIED PARTS BE USED FOR THE CRITICAL COMPONENTS IN THE Δ SYMBOL MARK OF THE SCHEMATIC.

Stand-by +3.3V +1.25V MST_Core

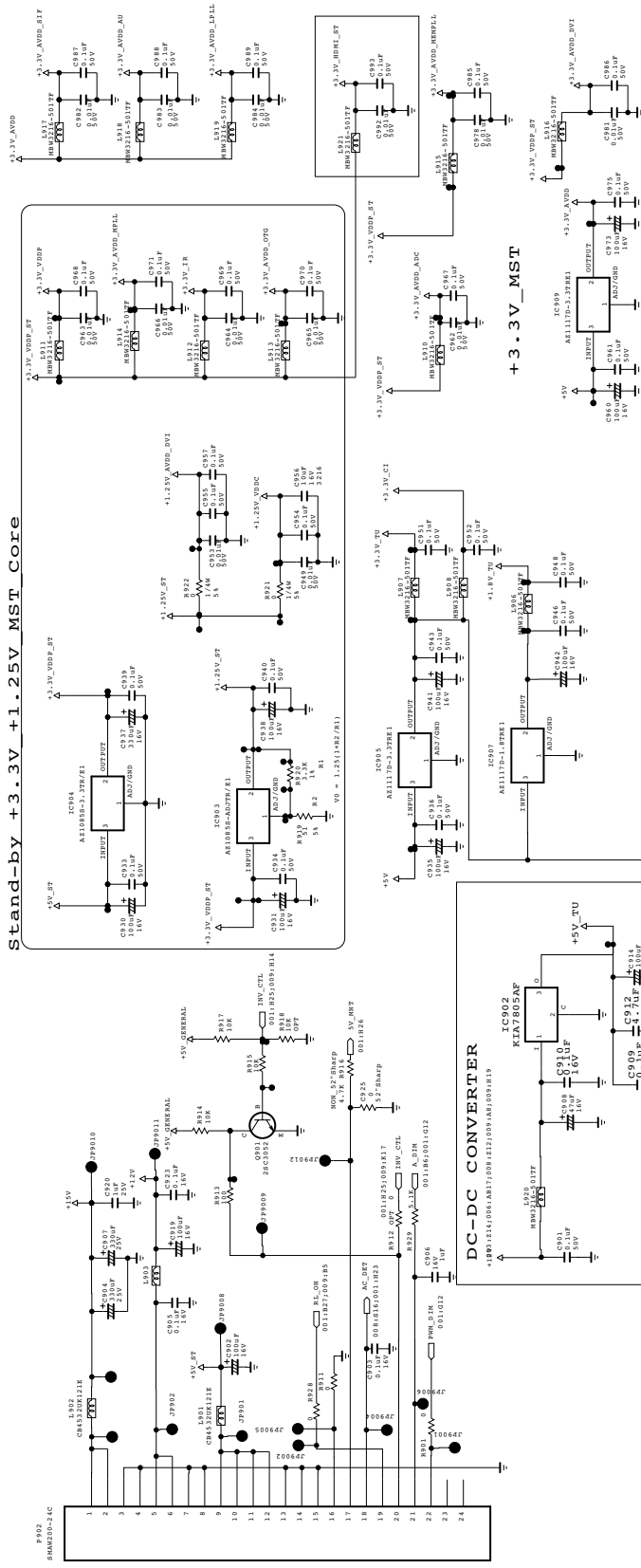

DC-DC CONVERTER

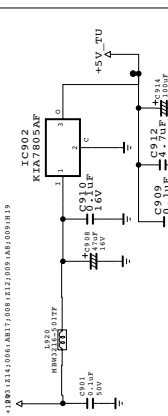

+3.3V_MST

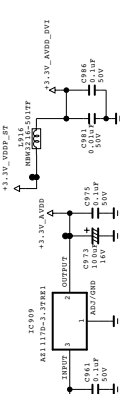

+5V_+12V

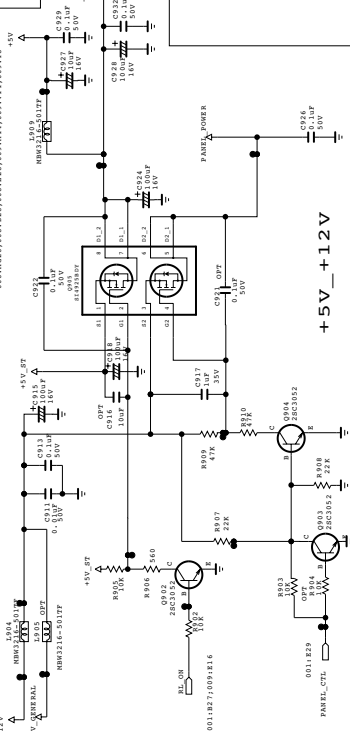

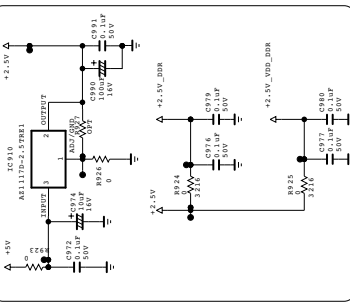

+2.5V_DDR





TUNER_CI +3.3V_+1.8V_+1.5V

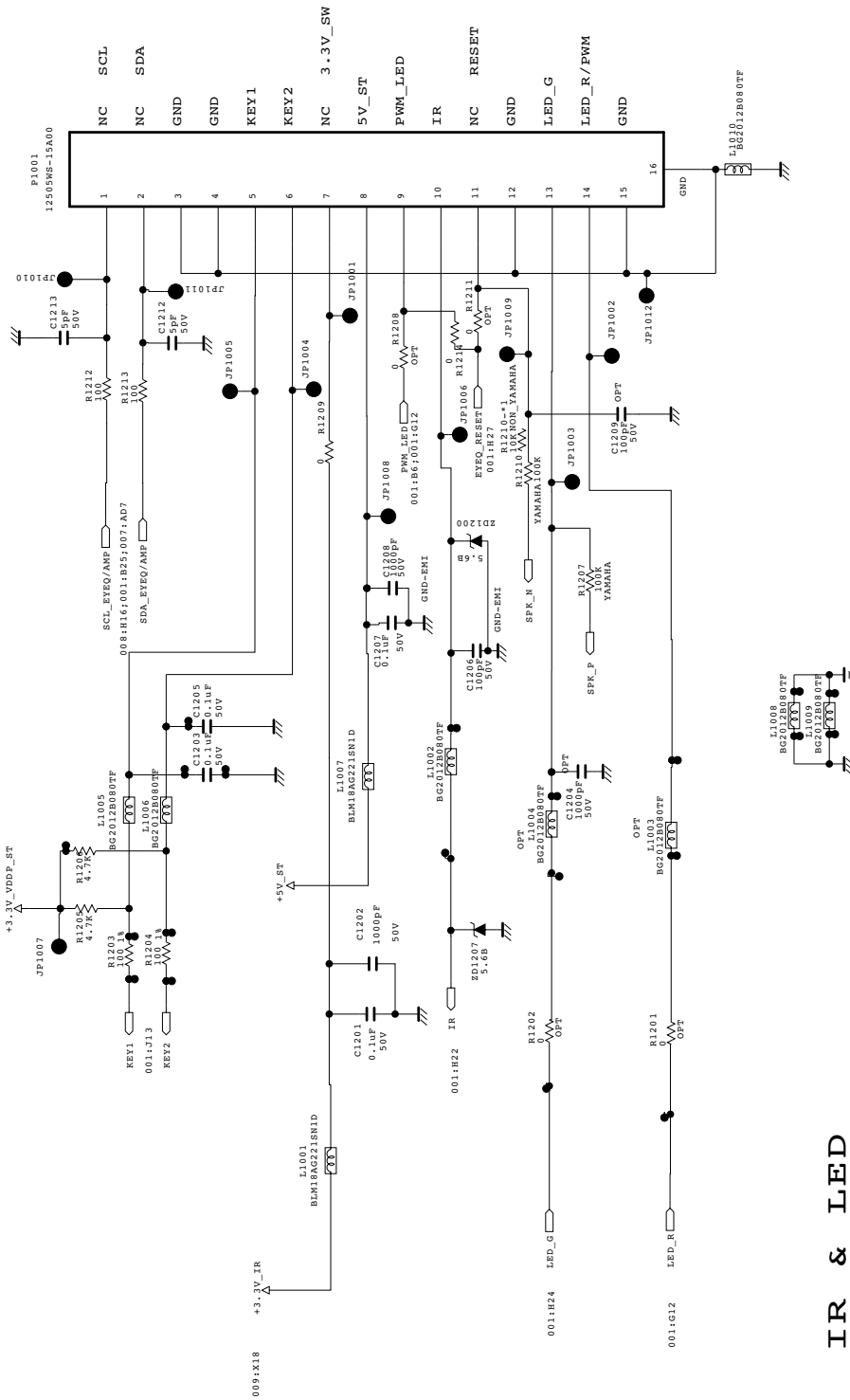

THE  SYMBOL MARK OF THIS SCHEMATIC DIAGRAM INCORPORATES SPECIAL FEATURES IMPORTANT FOR PROTECTION FROM X-RADIATION. FILE AND ELECTRICAL SHOCK HAZARDS. WHEN SERVICING IF IS ESSENTIAL THAT ONLY MANUFACTURERS SPECIFIED PARTS BE USED FOR THE CRITICAL COMPONENTS IN THE  SYMBOL MARK OF THE SCHEMATIC.

CONTROL



THE  SYMBOL MARK OF THIS SCHEMATIC DIAGRAM INCORPORATES SPECIAL FEATURES IMPORTANT FOR PROTECTION FROM X-RADIATION, FIRE AND ELECTRICAL SHOCK HAZARDS, WHEN SERVICING IF IS ESSENTIAL THAT ONLY MANUFACTURES SPECIFIED PARTS BE USED FOR THE CRITICAL COMPONENTS IN THE  SYMBOL MARK OF THE SCHEMATIC.

IR & LED



P/NO : MFL42276206

Jun., 2008
Printed in Korea

