

2 Phase Hybrid Stepper Motor 43H2A series-Size 110mm(1.8 degree)

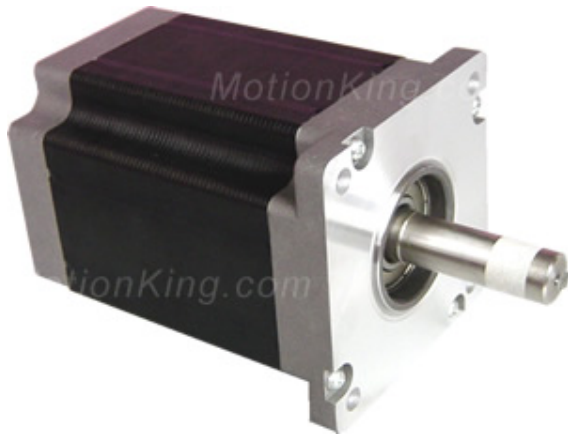

Wiring Diagram:

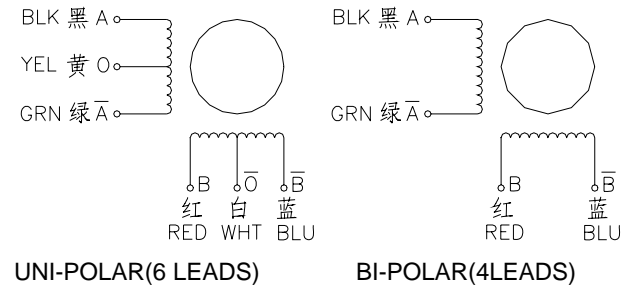

Electrical Specifications (BI-POLAR):

Series Model	Step Angle (deg)	Motor Length (mm)	Rated Current (A)	Phase Resistance (ohm)	Phase Inductance (mH)	Holding Torque (N.m Min)	Rotor Inertia (g.cm ²)	Lead Wire (No.)	Motor Weight (kg)
43H2A100-604	1.8	100	6.0	0.5	6	12.5	3500	4	5.5
43H2A115-604	1.8	115	6.0	0.95	15	14.0	5500	4	6.2
43H2A125-654	1.8	125	6.5	0.66	11	20.0	8500	4	7.5
43H2A150-654	1.8	150	6.5	1.15	18.9	23.0	11000	4	8.4
43H2A165-654	1.8	165	6.5	0.65	14	26.0	13000	4	11
43H2A200-654	1.8	200	6.5	1.00	21	30.0	15000	4	15

***Note:**

- 1) We can manufacture products according to customer's requirements.
- 2) We can also supply UNI-POLAR stepper motors, but not listed, the details please contact us.

Dimensions: unit=mm

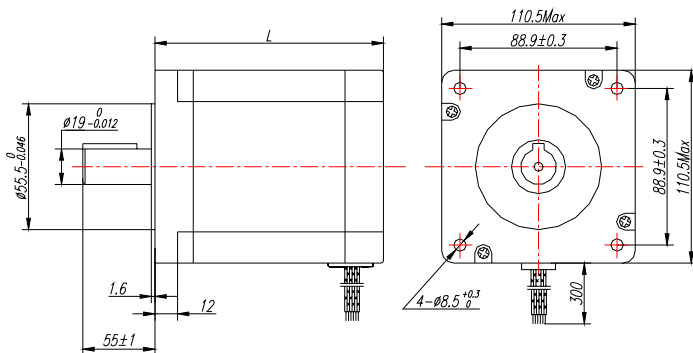

Motor Length:

Model	Length
43H2A100XX	100 mm
43H2A115XX	115 mm
43H2A125XX	125 mm
43H2A150XX	150 mm
43H2A165XX	165 mm
43H2A200XX	200 mm