

450-3320 Swage mount socket, for .040 (1,02) diameter pins.

Recommended mounting hole .094 (2,39) ±.002 (0,05), #42 drill

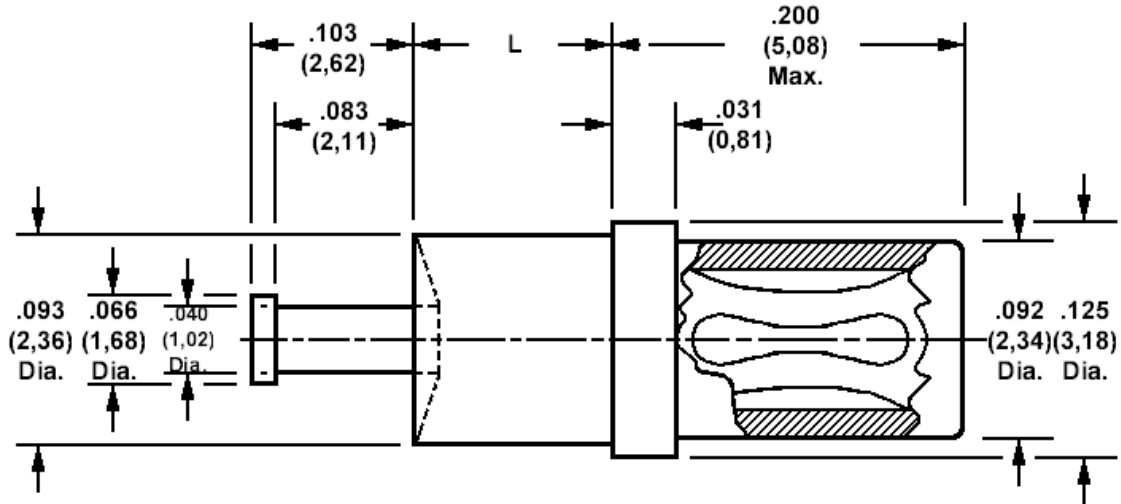

Min hole depth .190 (4,83)

How to order code

450-3320-YY-XX-00

Basic Part No YY = Board thickness XX = Finish

DIMENSIONS		
Dash No (YY)	'L'	Board Thickness
-01	.060 (1,57)	.031 (0,79)
-02	.094 (2,39)	.061 (1,57)
-03	.125 (3,18)	.094 (2,39)
-04	.156 (3,96)	.125 (3,18)
-05	.219 (5,56)	.187 (4,75)

MATERIALS				
Component	Material	Finish(-03)	Finish(-04)	Finish(-06)
Body	Brass	Gold over Nickel	Tin	Tin
Spring	Beryllium copper	Gold over Nickel	Tin	Gold over Nickel

TOOLING	
Recommended Swaging Tools:-	
Anvil	435-6404-01-00-00
Punch	435-6658-02-00-00