



LG

North/Latin America
Europe/Africa
Asia/Oceania

<http://aic.lgservice.com>
<http://eic.lgservice.com>
<http://biz.lgservice.com>

LCD TV

SCHEMATICS AND EXPLODED VIEW

CHASSIS : LA12C

MODEL : 47LW5600 47LW5600-UA

CAUTION

BEFORE SERVICING THE CHASSIS,
READ THE SAFETY PRECAUTIONS IN THIS MANUAL.

EXPLODED VIEW

IMPORTANT SAFETY NOTICE

Many electrical and mechanical parts in this chassis have special safety-related characteristics. These parts are identified by Δ in the Schematic Diagram and EXPLODED VIEW. It is essential that these special safety parts should be replaced with the same components as recommended in this manual to prevent X-RADIATION, Shock, Fire, or other Hazards. Do not modify the original design without permission of manufacturer.

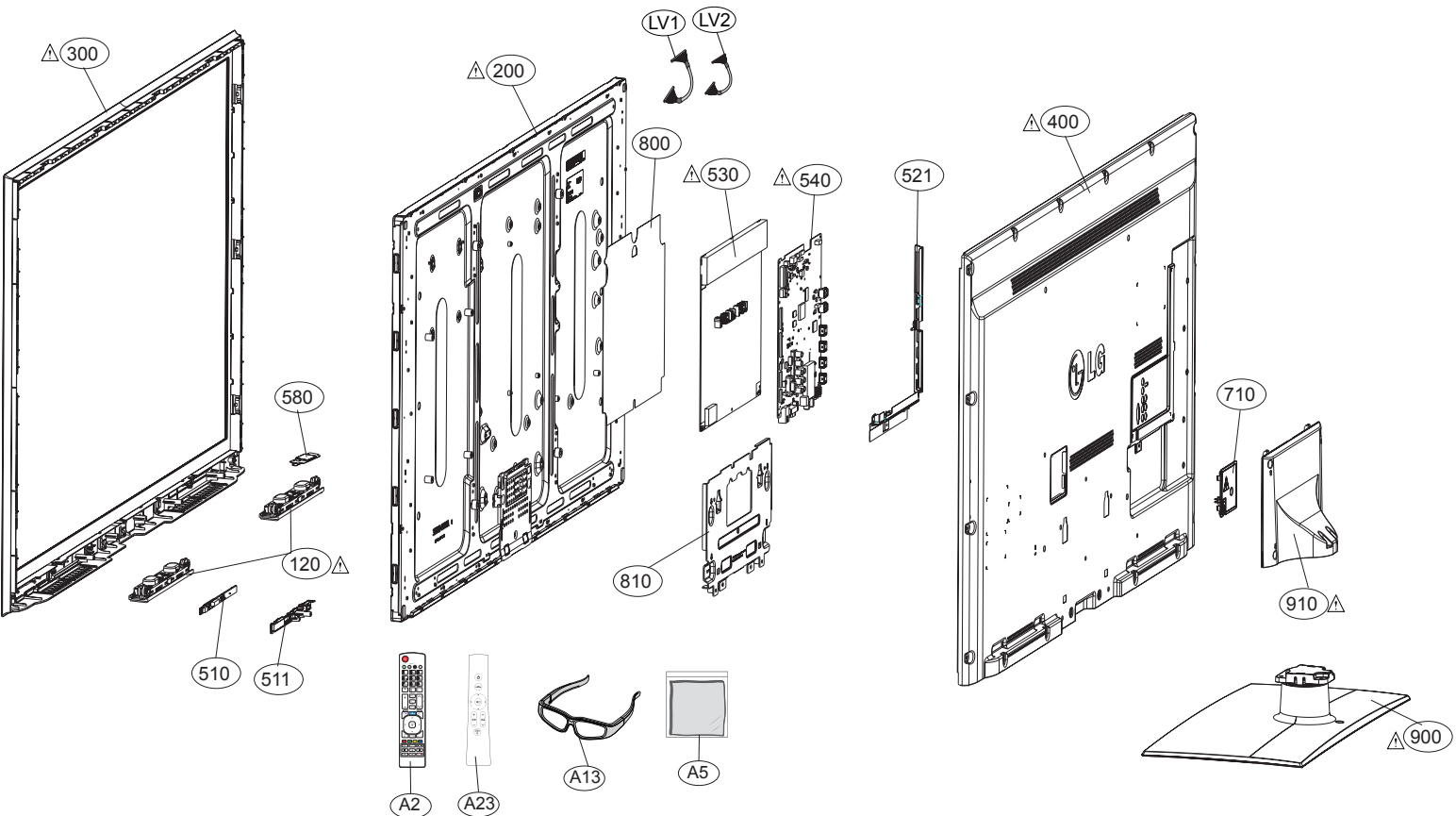

47LW5600 EXPLODED VIEW PARTS LIST

ITEM	PART No	DESCRIPTION
120	EAB62088401	Speaker :EN1080C-6795 ND 10W 8OHM 79DB 150HZ 200x25x27
200	EAJ61768201	Panel: LC470EUF-SDF1 FHD 47INCH 1920X1080 16/9 1600:1 240Hz(T) With Inverter and T-Con Edge V6 LG Display Co. Ltd. AUSYLHR, AUSYLJR, AL
200	EAJ61928101	Panel: LC470EUF-SDF1 FHD 47INCH 1920X1080 16/9 1600:1 240Hz(T) With Inverter and T-Con Edge V6 LG Display Co. Ltd. AUSYLUR
300	ABJ73289108	Front Frame: 47LW5600 Cabinet Assembly
400	ACQ85373502	Back Cover: 47LW5600
510	EBR72671301	IR + Soft Touch Assembly: LW4500
511	MAZ62853702	Soft Touch Bracket
521	MGJ62689302	Side AV Metal Bracket: (Around Main Board)
530	EAY62169801	Power Supply: LGP4247-11SLPB FREE LGP4247-11SLPB LCD HNE/YUYANG/LGIT/LIENCHANG - H&E CO.,LTD
540	EBR72948402	Main Board: BPR Insert PCB Assembly AUSYLHR
540	EBR73145901	Main Board: BPR Insert PCB Assembly AUSYLJR
540	EBR72948404	Main Board: BPR Insert PCB Assembly AUSYLUR
580	EBR72499601	Motion Remote Receiver Board (M3)
710	MAZ62827604	Decorative Piece Around Power Cord
800	AGU73528803	Insulator Sheet behind Power Supply: (Insulation assy to attach on module for 42/47)
810	MJH62198002	Stand Guide Metal
900	AAN73430406	Stand Base
910	MJH62197902	Stand Supporter
A2	AKB73295502	Remote Control
A3	EAD60817902	AC Power Cord 1.625M 75MM 125V 10A SVT 18AWG 3C BLACK. UL/CSA
A5	MAF60779001	Cloth Cleaner
A7	EAT60713304	Dongle WN8522B2-LF-19 AN-WF100 BCM4323 802.11a/b/g/n
A10	FAB30016104	Screw: FAB30016104 Machine Type D4.0 L12.0 Washer D8.5 t0.6
A21	MCK66265801	Remocon Battery Cover
A13	EBX61268401	Accessory,3D Glasses
A23	AKB72914043	Motion Remote Controller (M3)
LV1	EAD61652505	LVDS 455MM 0.50MM 41P White UL20861 Reverse A: 95mm B: 220mm C: 160mm D: 55mm
LV2	EAD61668615	LVDS 365MM 0.50MM 51P White UL20861 reverse Locking A: 95mm B: 180mm C: 125mm D: 55mm

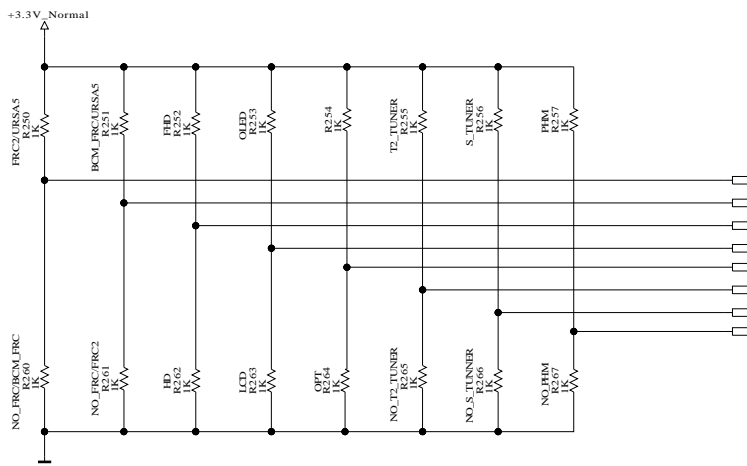

MODEL OPTION

MODEL_OPTION	NO_FRC	BCM Internal FRC	LG FRC2	external URSAS
MODEL_OPT_0	0	0	1	1
MODEL_OPT_1	0	1	0	1
MODEL_OPT_2		HIGH	LOW	
MODEL_OPT_3		FHD	HD	
MODEL_OPT_4		OLED	LCD	
MODEL_OPT_5		DDR speed	1333	1600
MODEL_OPT_6		T2 Tuner	Support	Not Support
MODEL_OPT_7		S Tuner	Support	Not Support
MODEL_OPT_8		PHM	Enable	Disable

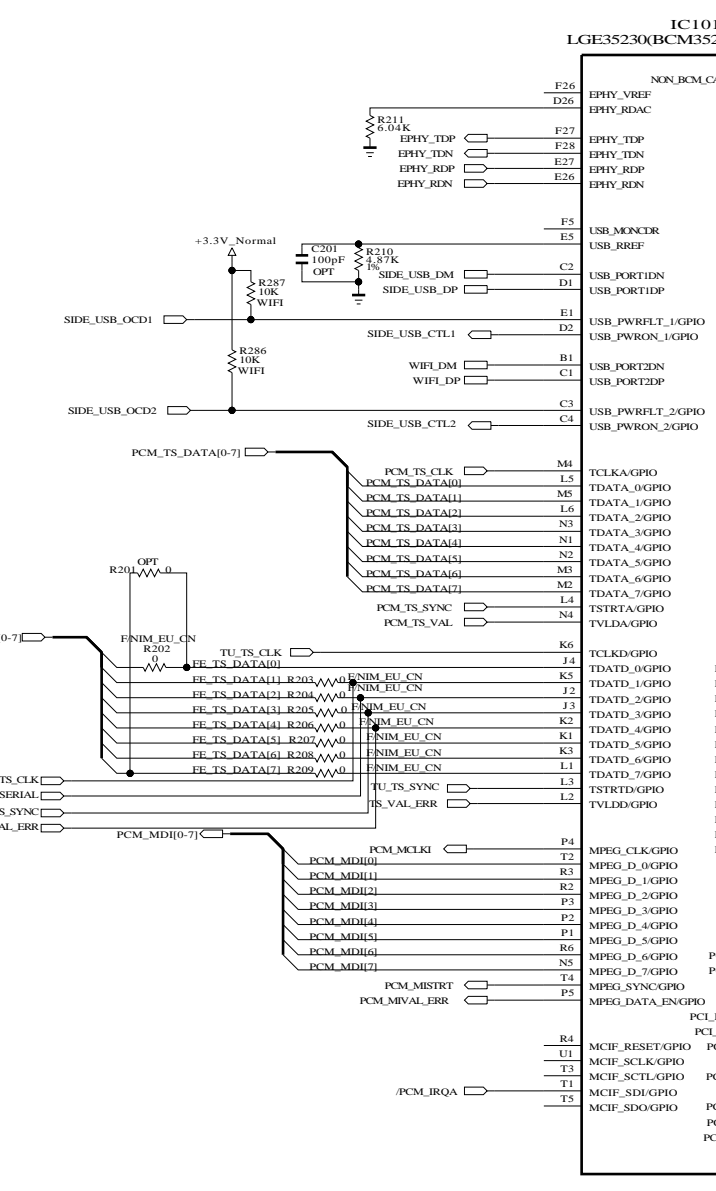
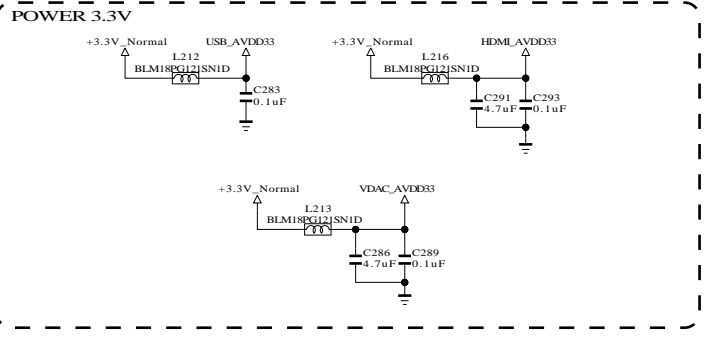
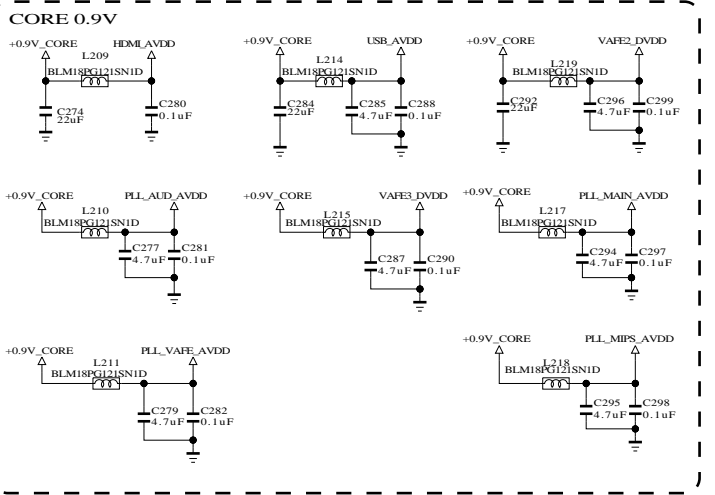
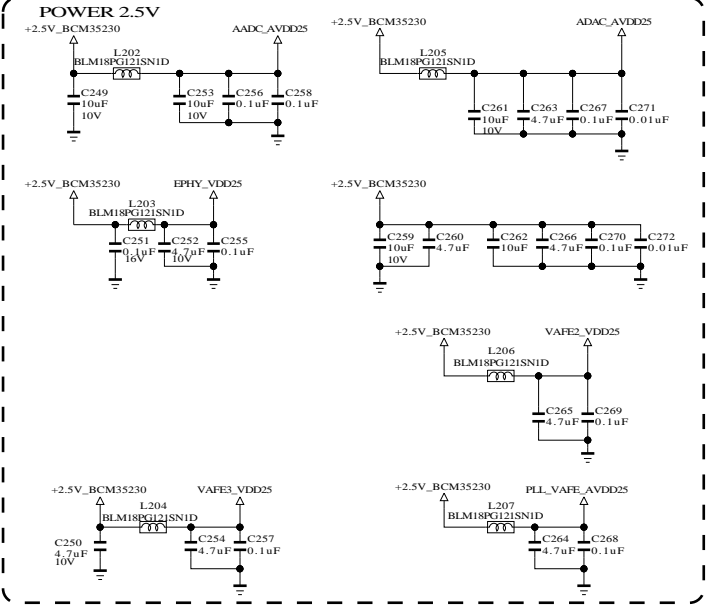
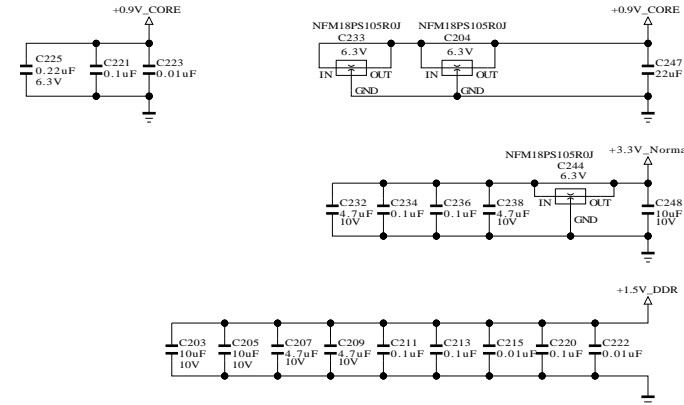

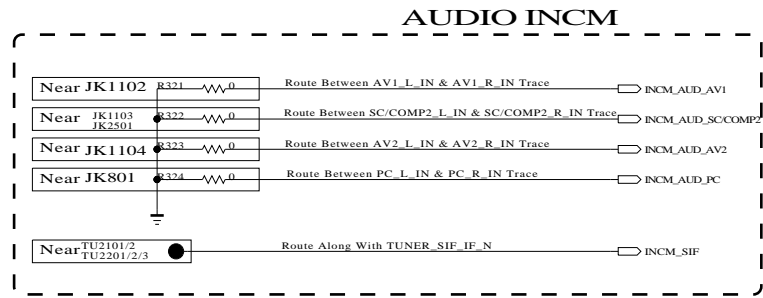
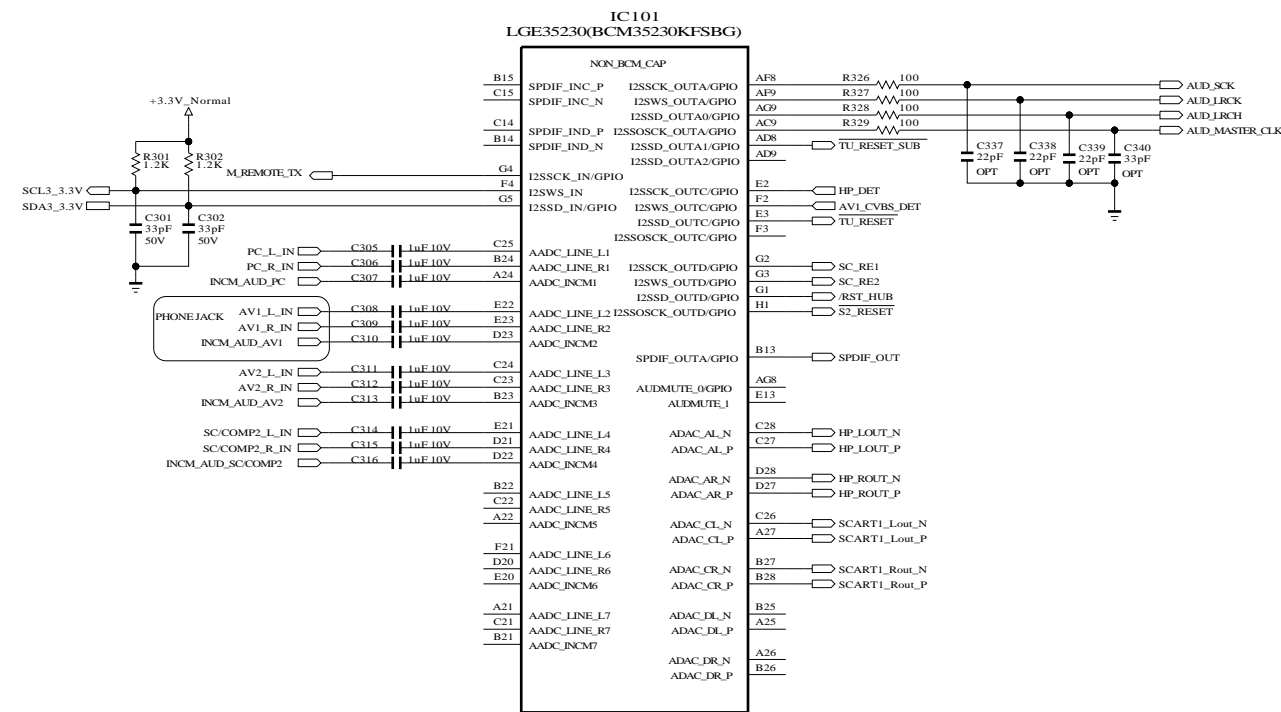
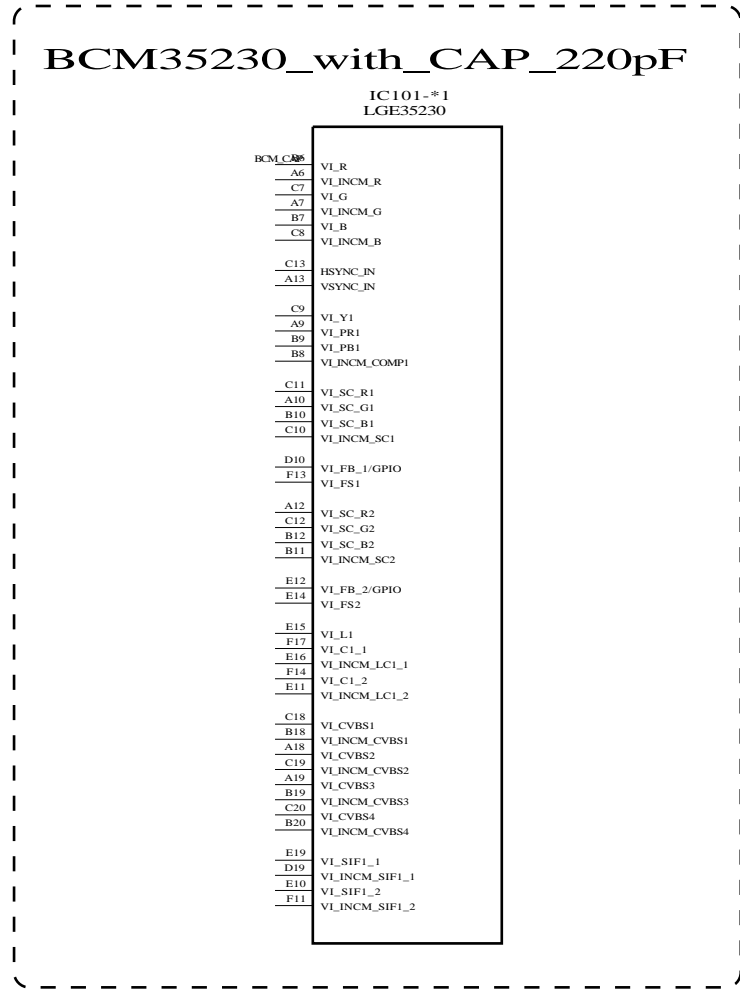
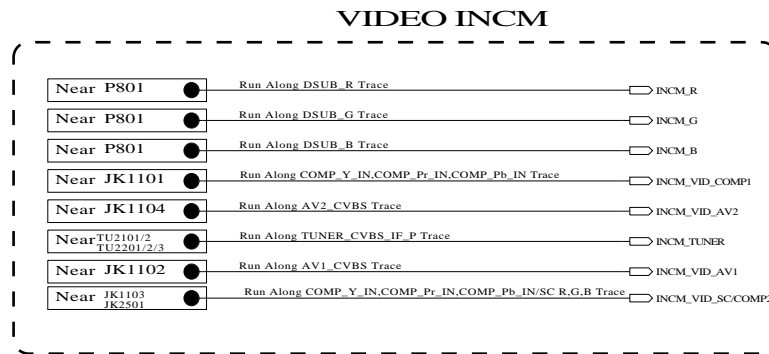
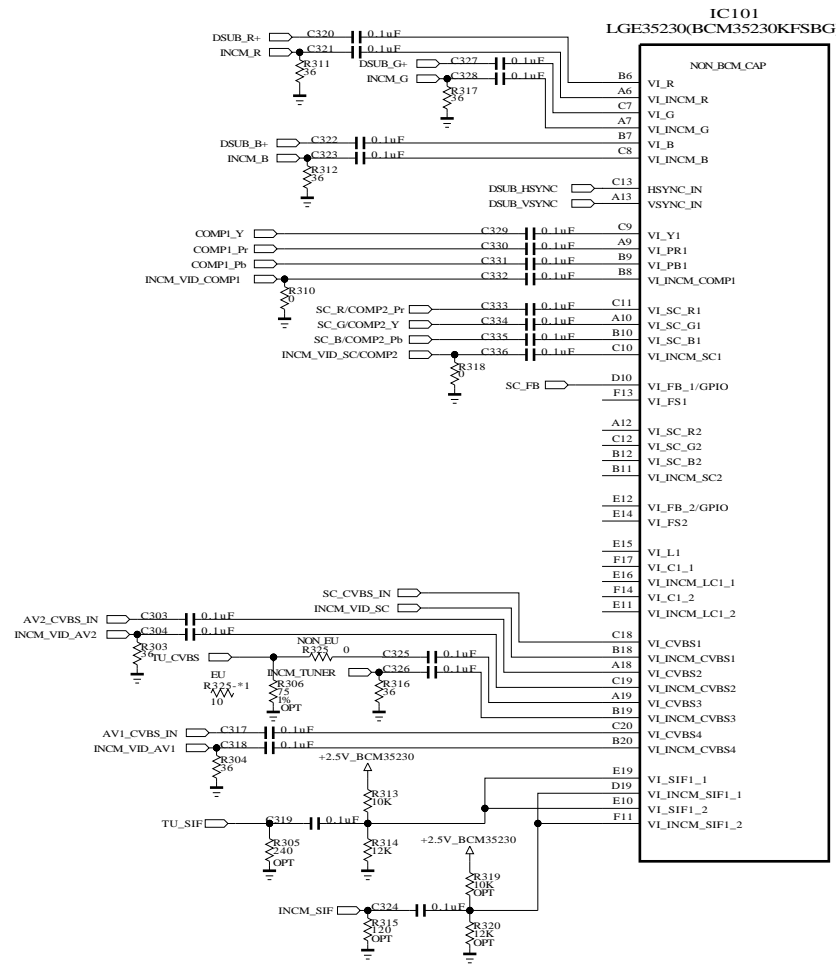

THE SYMBOL MARK OF THIS SCHEMATIC DIAGRAM INCORPORATES SPECIAL FEATURES IMPORTANT FOR PROTECTION FROM X-RADIATION. FILRE AND ELECTRICAL SHOCK HAZARDS, WHEN SERVICING IF IS ESSENTIAL THAT ONLY MANUFACTURES SPECIFIED PARTS BE USED FOR THE CRITICAL COMPONENTS IN THE SYMBOL MARK OF THE SCHEMATIC.

SECRET
LGElectronics



MODEL	BCM35230	DATE	
BLOCK	MAIN AUDIO/VIDEO	SHEET	3 / 50

DUAL COMPONENT	
IC401,IC402	1ST : EAN61667501, 2ND : EAN61570701
IC401-*1 IC402-*1	1ST : T-K4B2G1646B_HCK0, 2ND : T-H5TQ2G63BFR-PBC

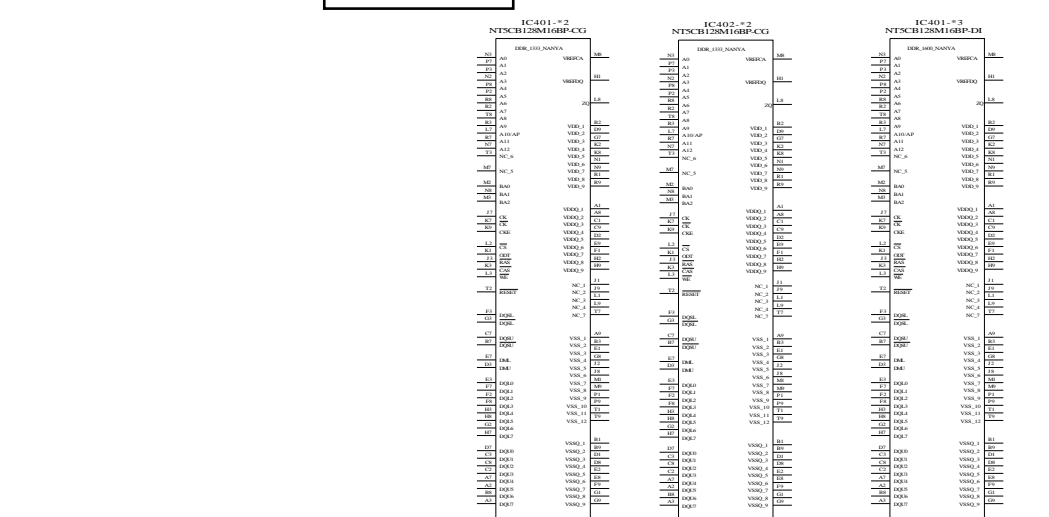
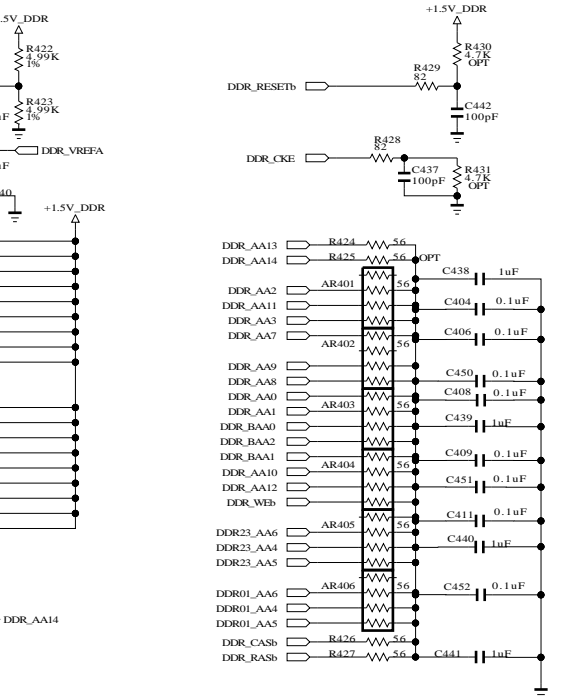
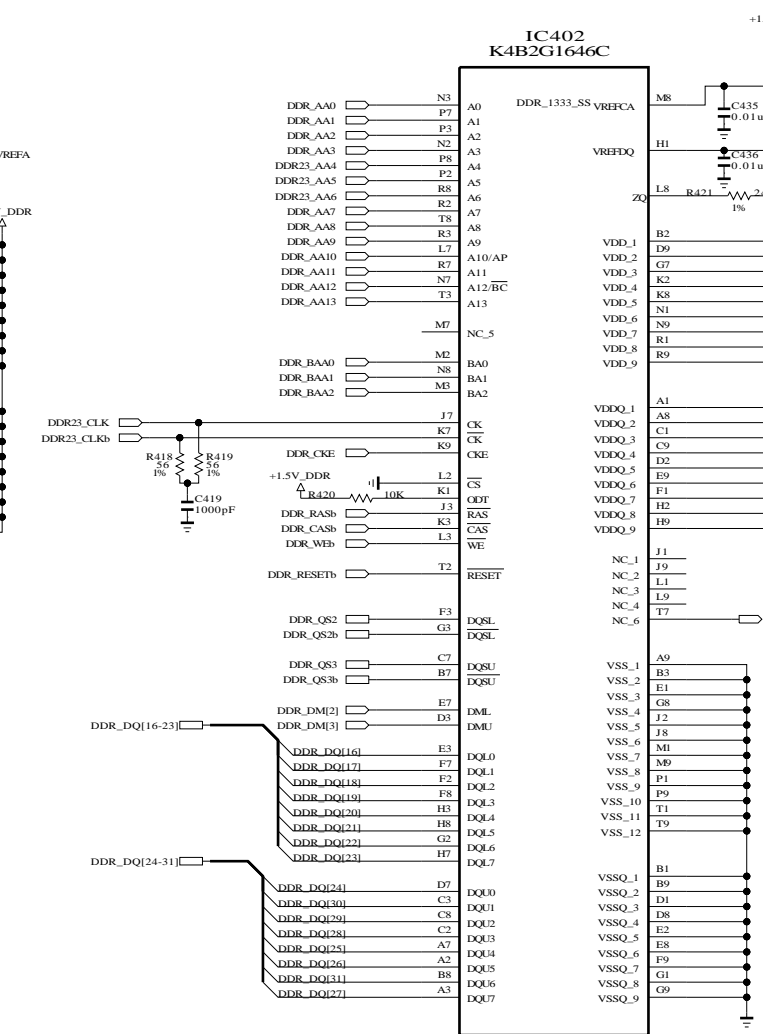
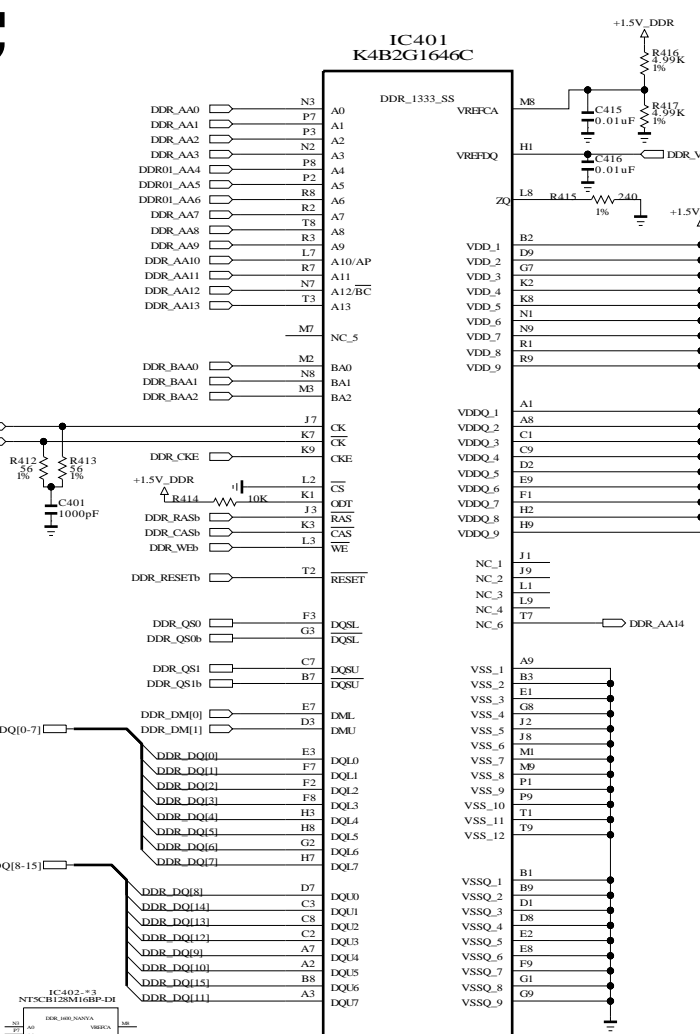
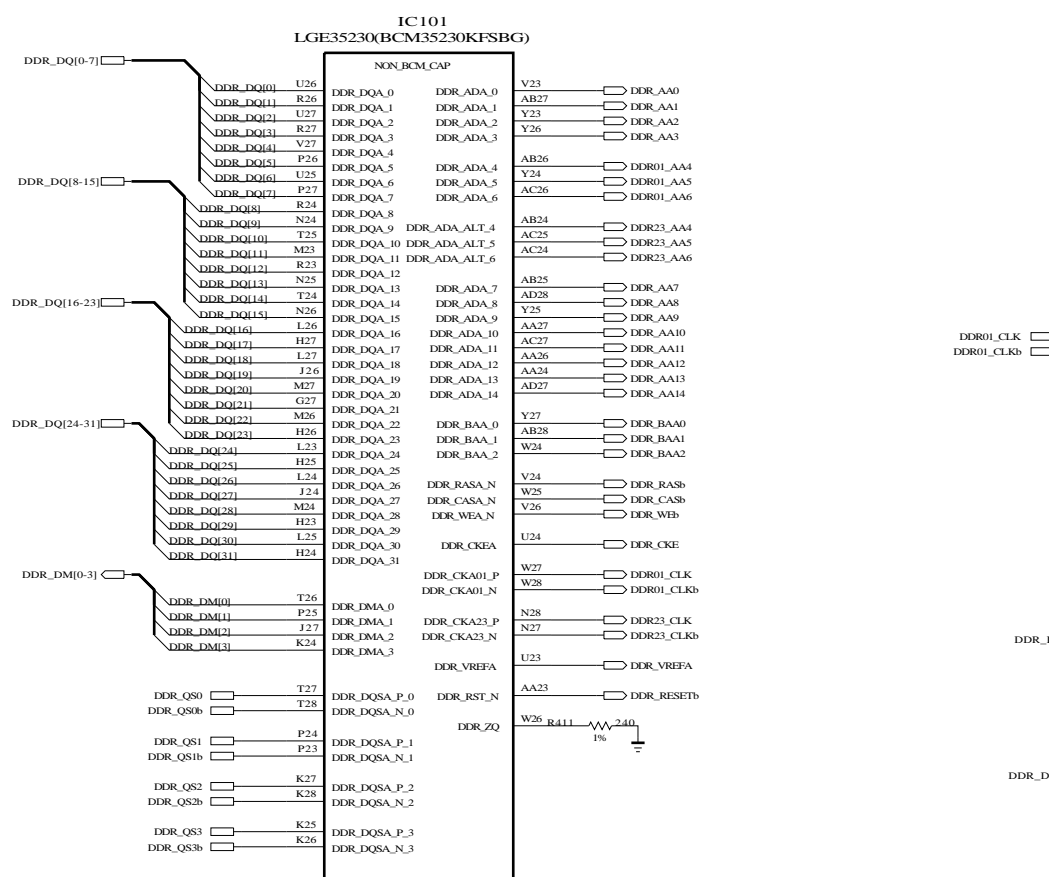
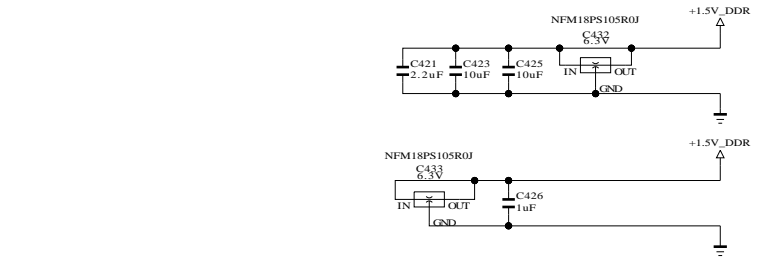
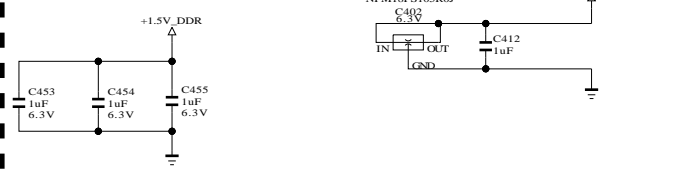
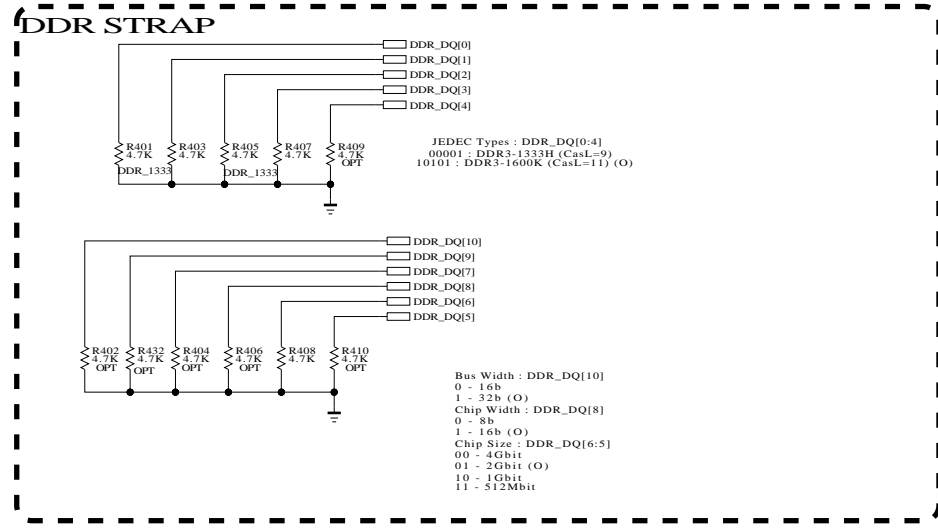

THE SYMBOL MARK OF THIS SCHEMATIC DIAGRAM INCORPORATES SPECIAL FEATURES IMPORTANT FOR PROTECTION FROM X-RADIATION. FILRE AND ELECTRICAL SHOCK HAZARDS, WHEN SERVICING IF IS ESSENTIAL THAT ONLY MANUFACTURES SPECIFIED PARTS BE USED FOR THE CRITICAL COMPONENTS IN THE SYMBOL MARK OF THE SCHEMATIC.

SECRET
LGElectronics



MODEL	BCM35230	DATE	
BLOCK	MAIN DDR	SHEET	4 / 50

FROM LIPS & POWER B/D

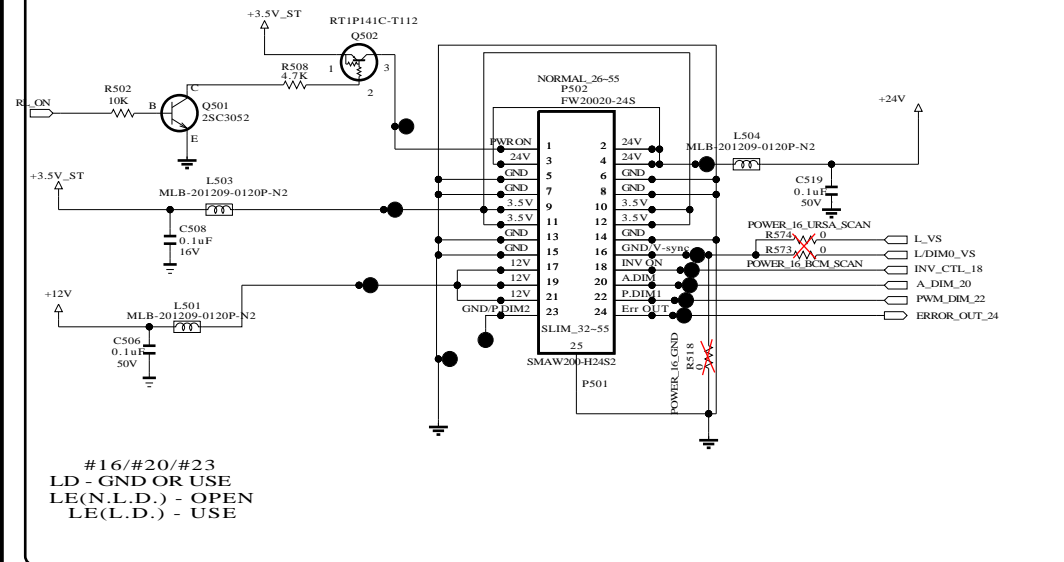

#16/#20/#23
LD - GND OR USE
LE(N.L.D.) - OPEN
LE(L.D.) - USE

DUAL COMPONENT	
Q501,Q504, Q505,Q506	1ST : 0TRIY80001A 2ND : 0TR387500AA
Q502	1ST : 0TRIH80004A, 2ND : EBK61012501, 3RD : 0TR102009AM
Q507	1ST : EBK60752501, 2ND : EBK61011501
IC502,IC503	1ST : EAN61151001, 2ND : EAN60670101

OS Module OPT

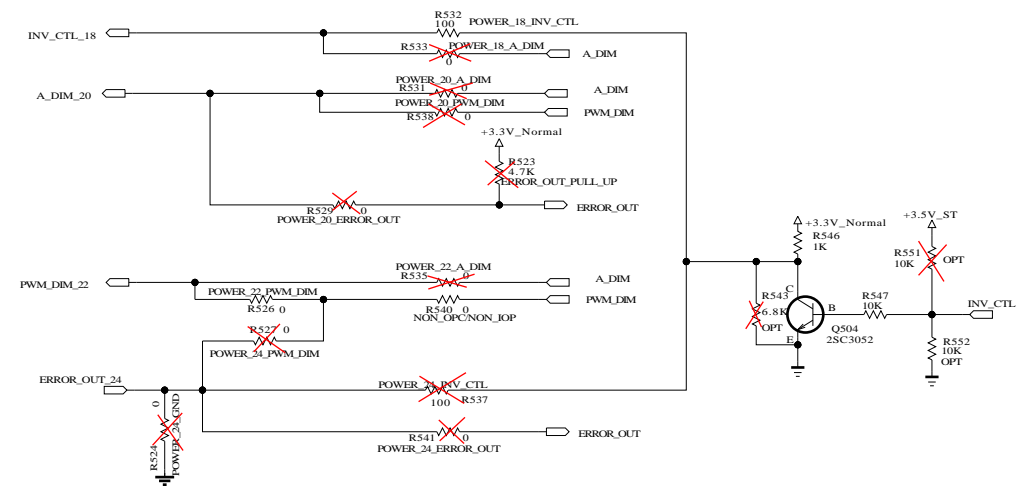

<OS MODULE PIN MAP>

PIN No	LGD	CMO(09)	AUO	SHARP
18	INV_ON	A-DIM	INV_ON	INV_ON
20	V4:VBR-A V5:NC	NC	Err_out	Err_out
22	PWM_DIM	PWM_DIM	A-DIM	PWM_DIM
24	Err_out LED:GND	INV_ON	PWM_DIM	GND

CHECK PWR/MODULE PIN MAP

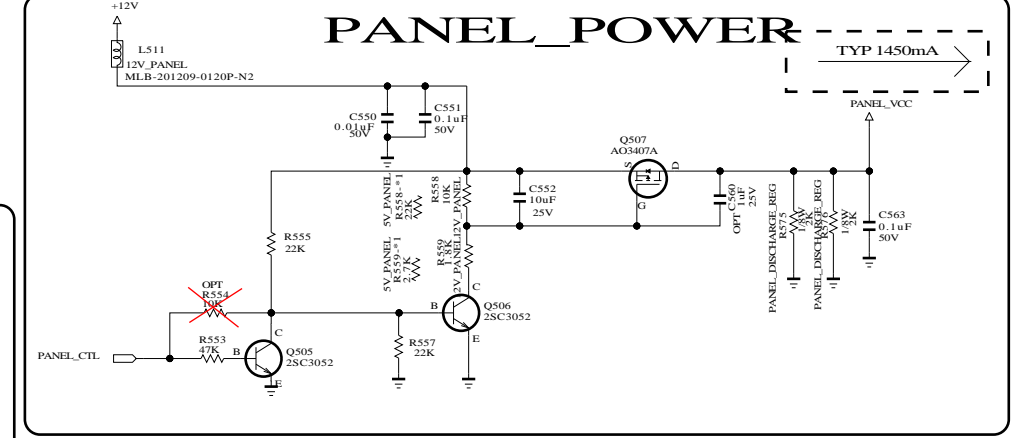

+1.5V_DDR

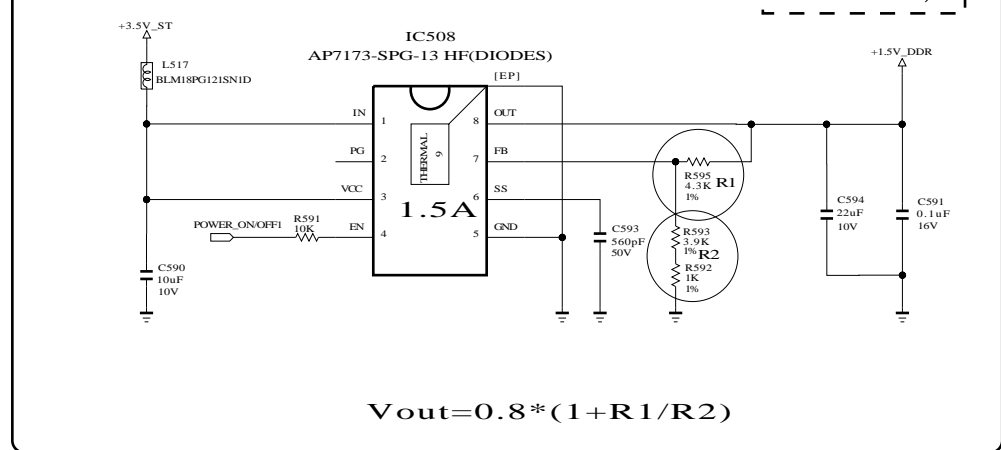

Power_DET

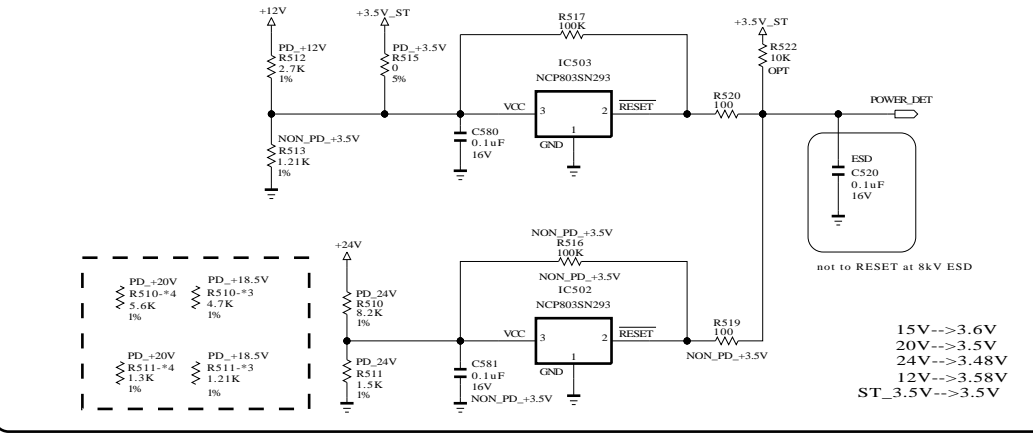

+0.9V_CORE_BCM35230

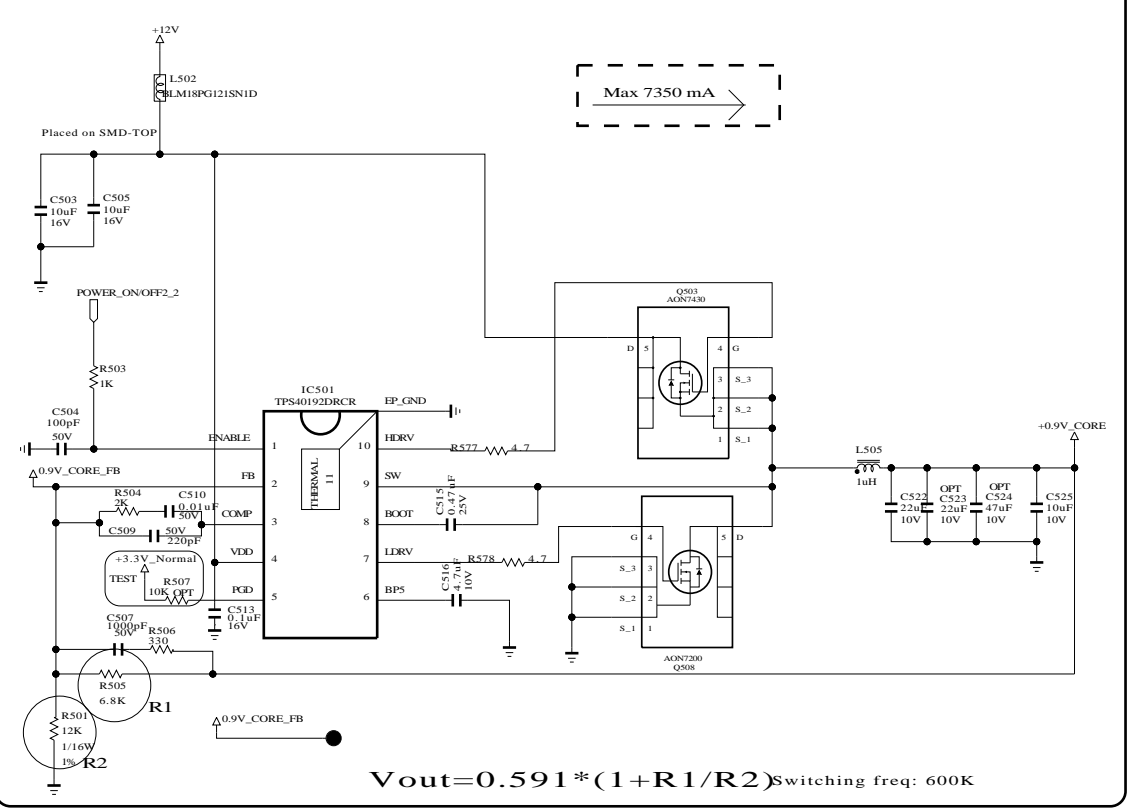

+3.3V_NORMAL

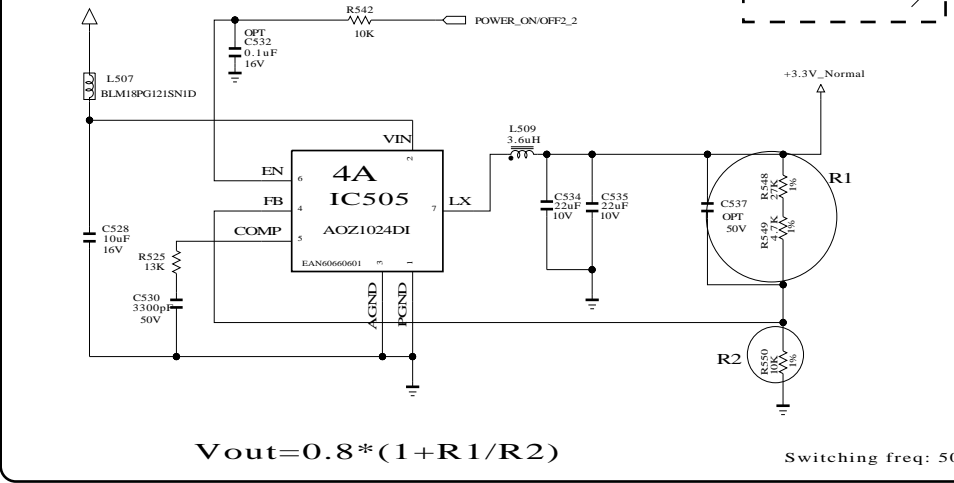

+2.5V_BCM35230

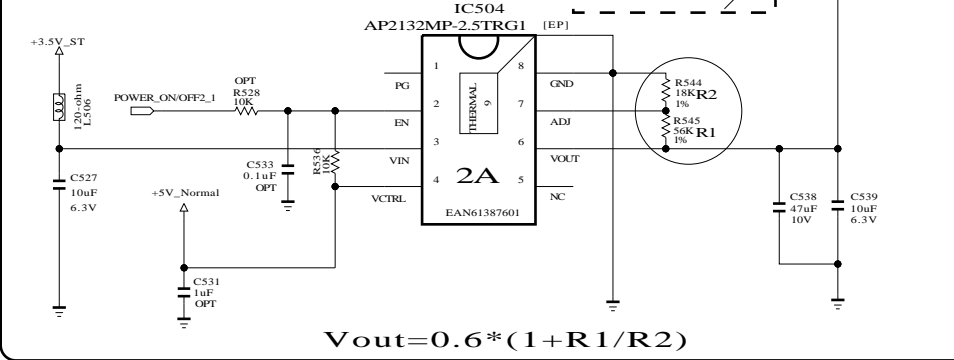

+5V_Normal

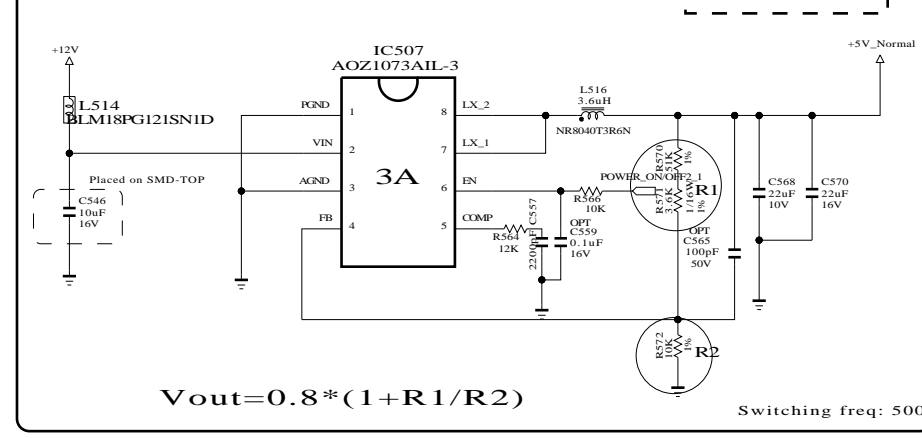

+5V_USB+WIFI

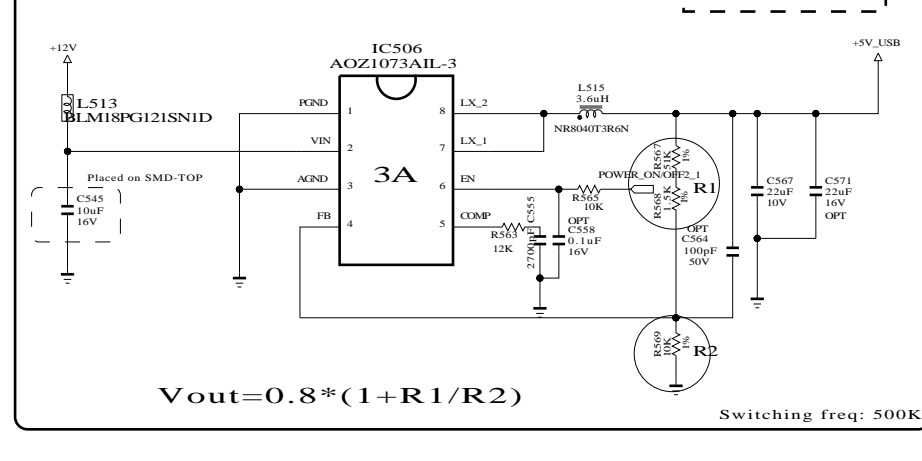

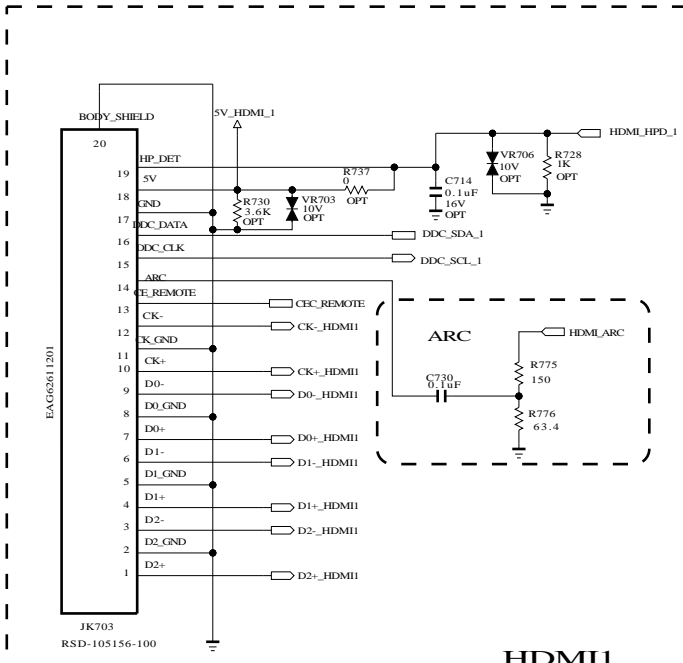

HDMI1

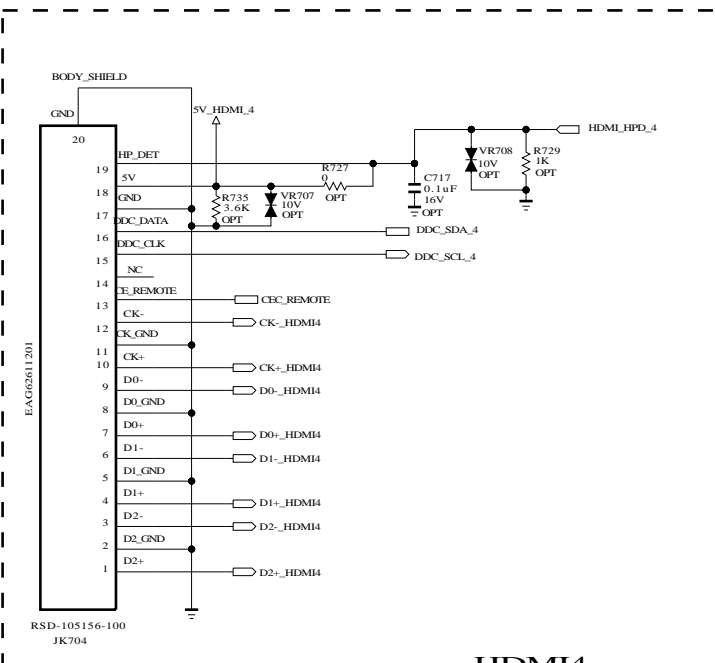

HDMI4

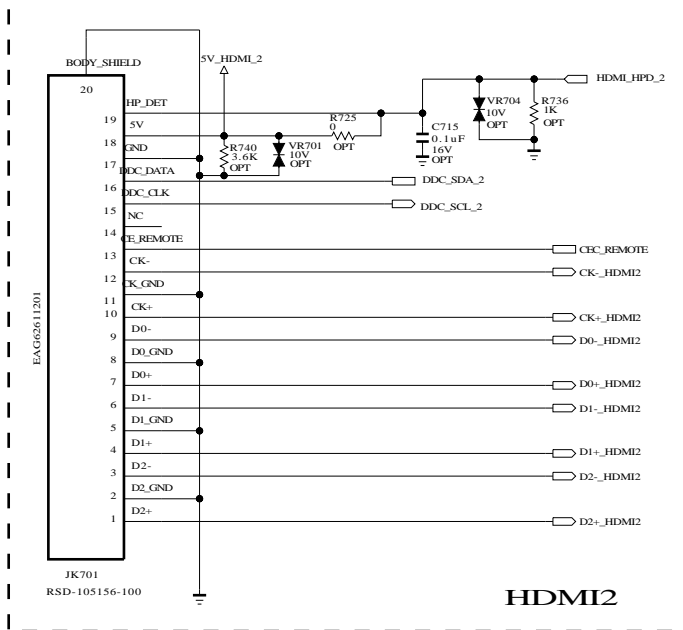

HDMI2

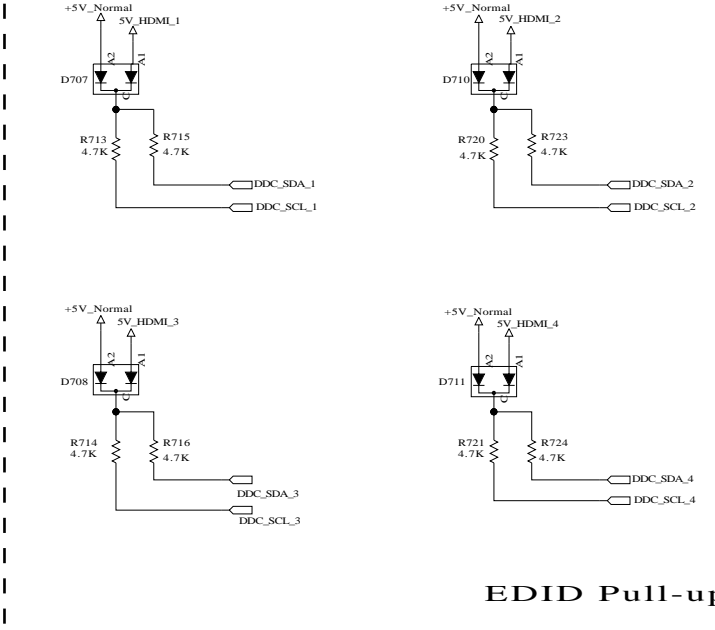

EDID Pull-up

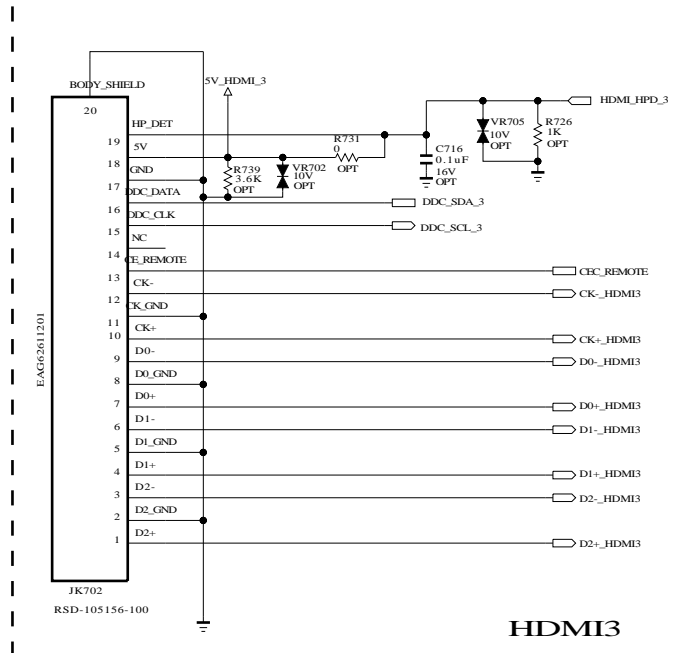

HDMI3

DUAL COMPONENT	
D707,D708 D710,D711	1ST : 0DD184009AA 2ND : 0DSIH00028A
D713	1ST : T-BAT54_SUZHO, 2ND : 0DSON00138A

* HDMI CEC

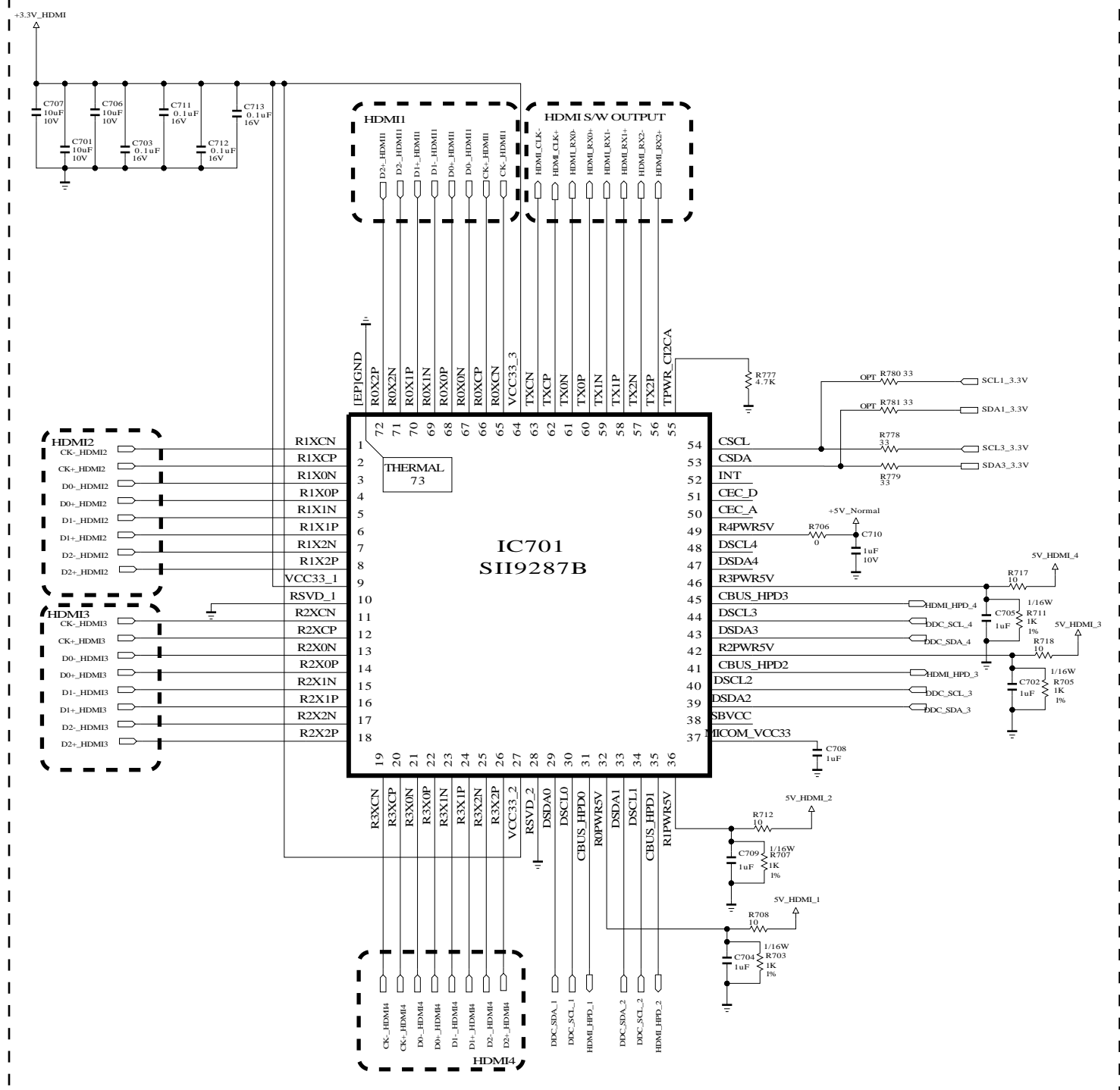
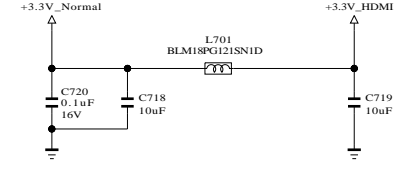
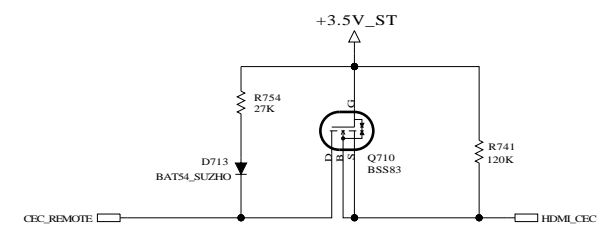

THE SYMBOL MARK OF THIS SCHEMATIC DIAGRAM INCORPORATES SPECIAL FEATURES IMPORTANT FOR PROTECTION FROM X-RADIATION, FILRE AND ELECTRICAL SHOCK HAZARDS, WHEN SERVICING IF IS ESSENTIAL THAT ONLY MANUFACTURES SPECIFIED PARTS BE USED FOR THE CRITICAL COMPONENTS IN THE SYMBOL MARK OF THE SCHEMATIC.

SECRET
LGElectronics



MODEL	BCM35230	DATE	
BLOCK	HDMI	SHEET	7 / 31

RGB PC

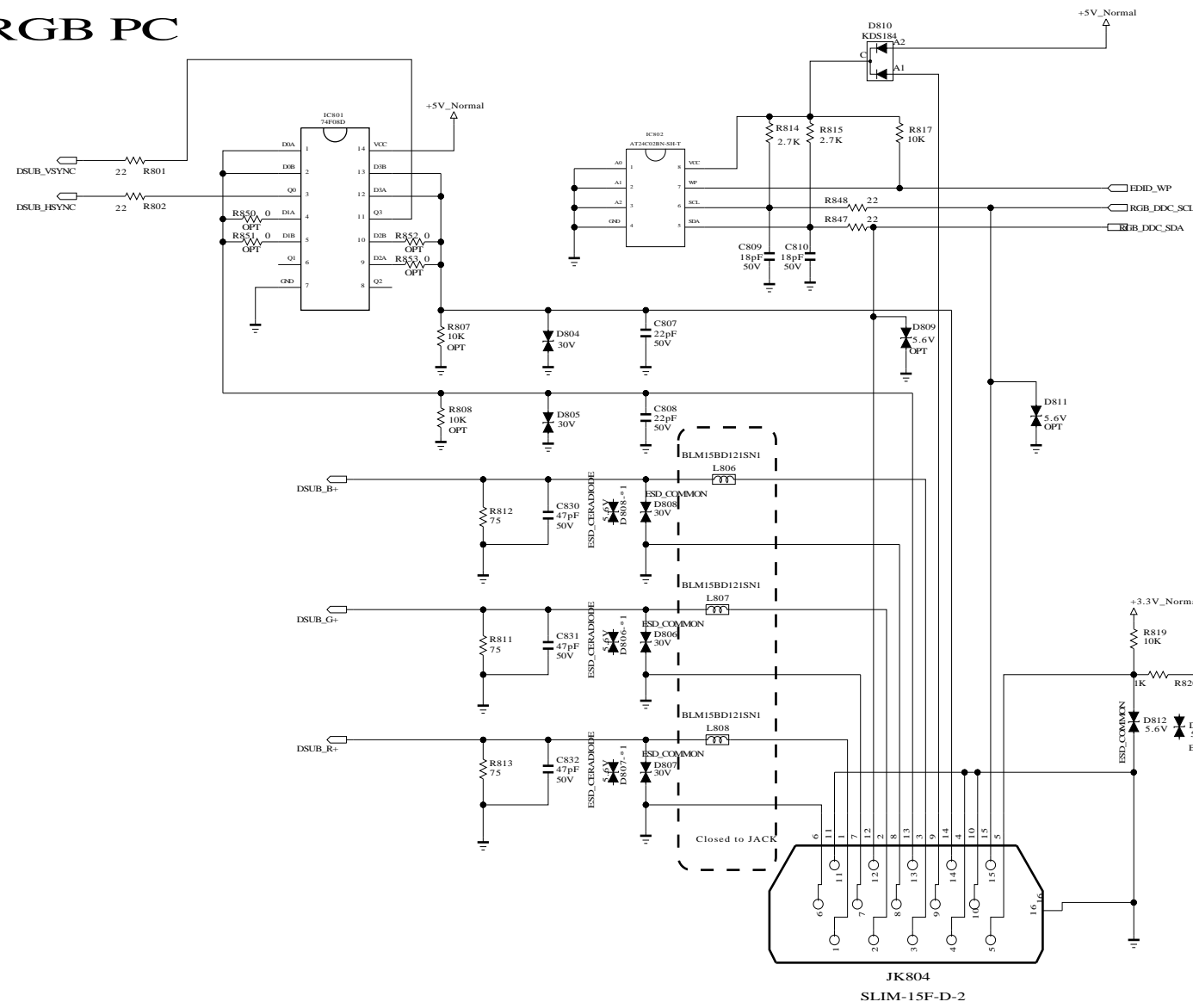

EARPHON JACK

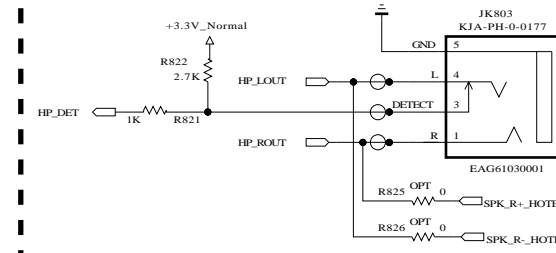

DUAL COMPONENT	
D804, D805, D806 D807, D808, D813 D814	1ST : EAH39491601, 2ND : EAH33945901
D810	1ST : 0DD184009AA, 2ND : 0DSIH00028A
Q801	1ST : 0TRIY80001A, 2ND : 0TR387500AA
IC805	1ST : EAN61151201, 2ND : EAN61130001

EARPHONE AMP

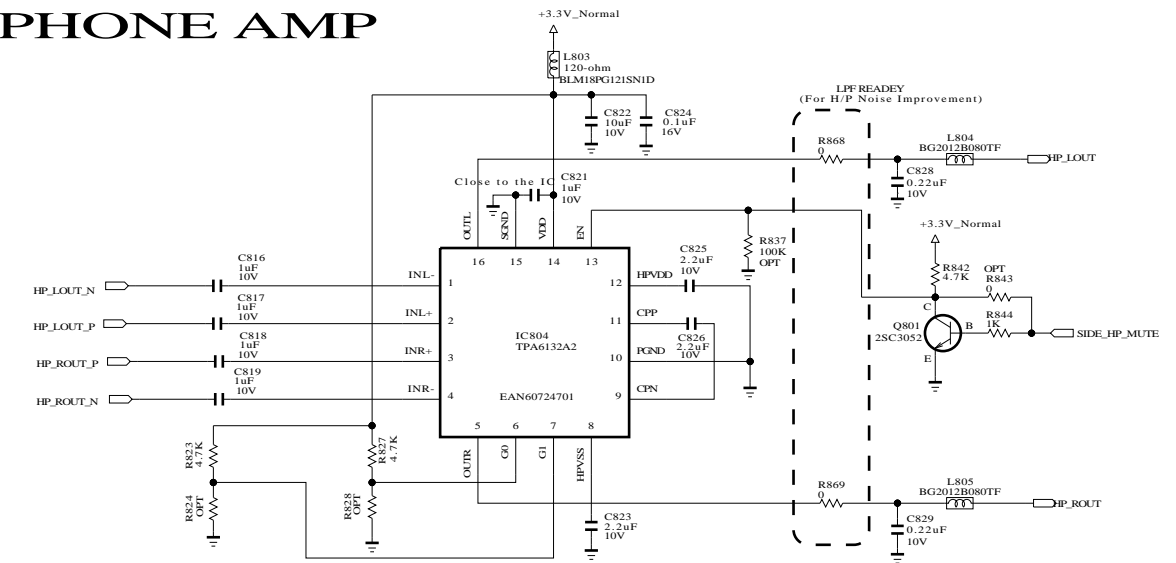

PC AUDIO

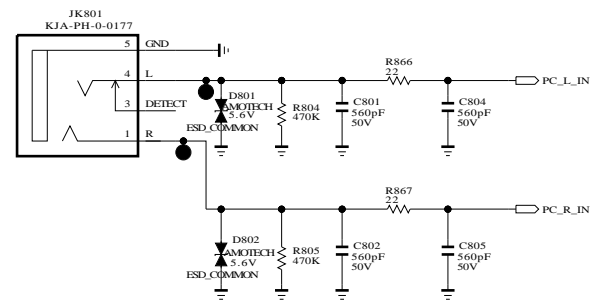

SPDIF OUT

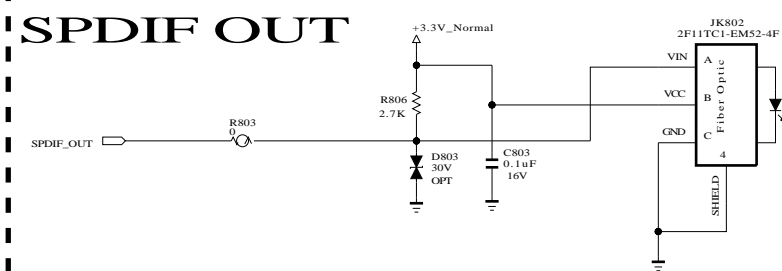

RS232C

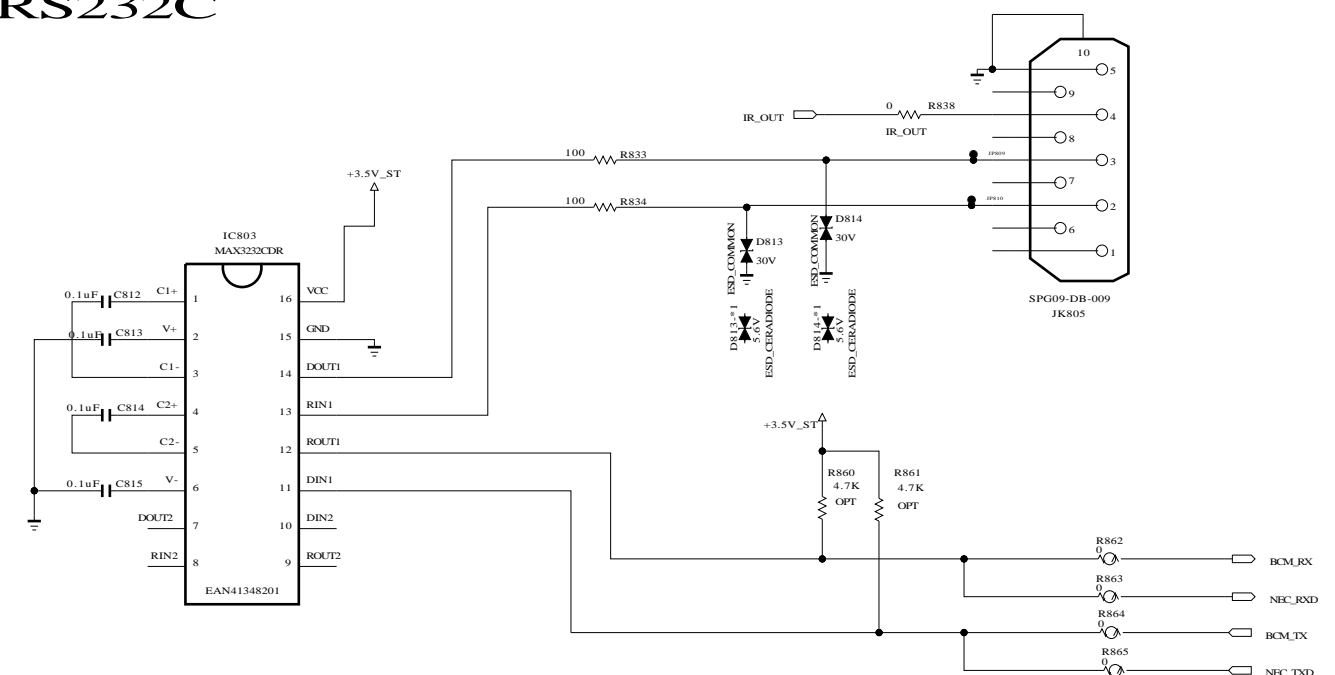

THE SYMBOL MARK OF THIS SCHEMATIC DIAGRAM INCORPORATES SPECIAL FEATURES IMPORTANT FOR PROTECTION FROM X-RADIATION. FILRE AND ELECTRICAL SHOCK HAZARDS, WHEN SERVICING IF IS ESSENTIAL THAT ONLY MANUFACTURES SPECIFIED PARTS BE USED FOR THE CRITICAL COMPONENTS IN THE SYMBOL MARK OF THE SCHEMATIC.

SECRET
LGElectronics



MODEL	BCM35230	DATE	2010.10.21
BLOCK	COMMON JACK	SHEET	8 / 58

DUAL COMPONENT	
Q901,Q902,Q903 Q904,Q905,Q906	1ST : 0TRIY80001A 2ND : 0TR387500AA
D903,D904 D905,D906	1ST : EAH42720601, 2ND : EAH60994401

IR & KEY

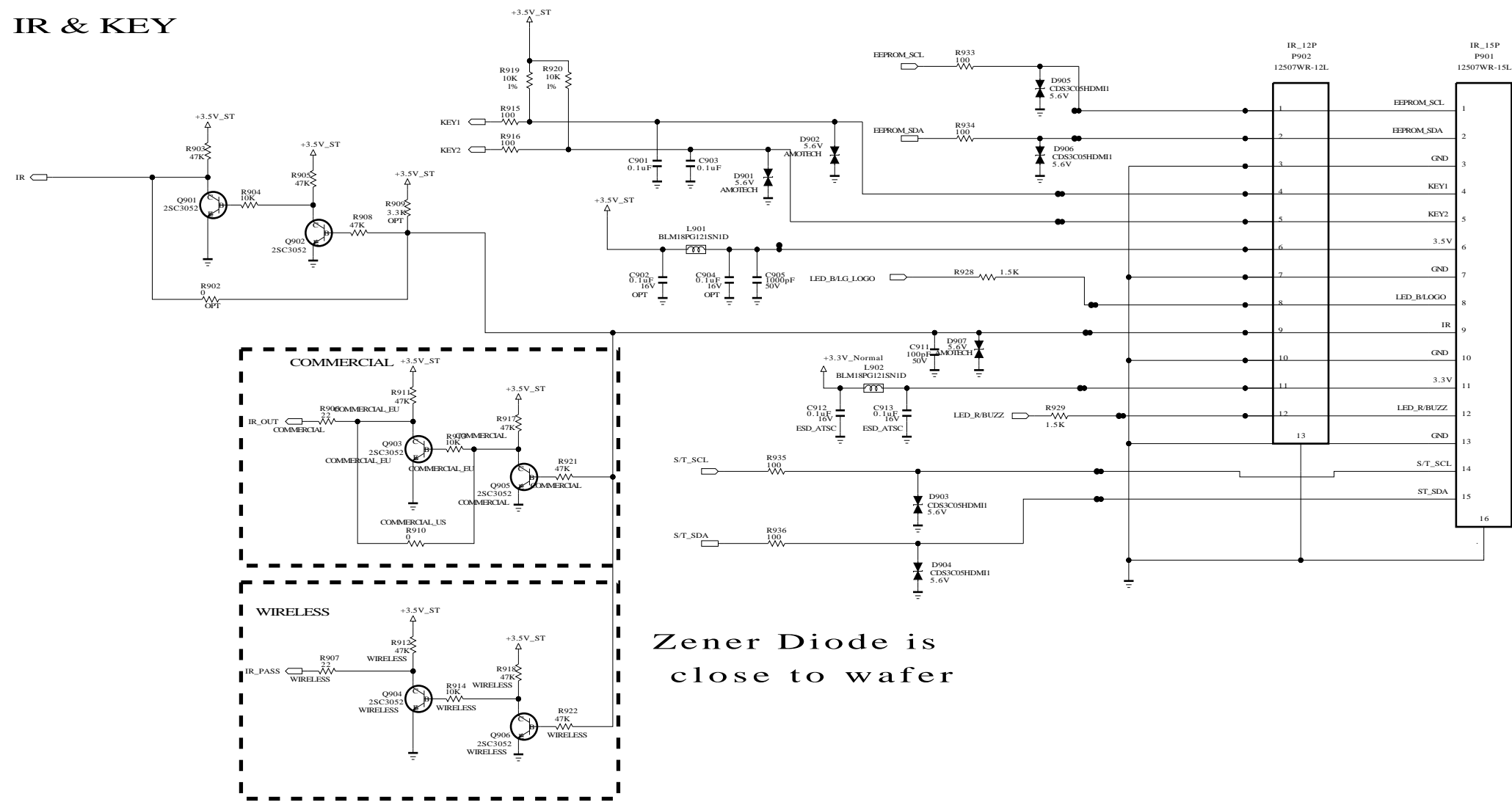

Zener Diode is close to wafer

THE SYMBOL MARK OF THIS SCHEMATIC DIAGRAM INCORPORATES SPECIAL FEATURES IMPORTANT FOR PROTECTION FROM X-RADIATION, FILRE AND ELECTRICAL SHOCK HAZARDS, WHEN SERVICING IF IS ESSENTIAL THAT ONLY MANUFACTURES SPECIFIED PARTS BE USED FOR THE CRITICAL COMPONENTS IN THE SYMBOL MARK OF THE SCHEMATIC.

SECRET
LGElectronics



MODEL	BCM35230	DATE	
BLOCK	IR/KEY	SHEET	9 / 50

WIRELESS READY MODEL

DUAL COMPONENT	
D1001,D1002	1ST : EAH42720601 2ND : EAH60994401
Q1001	1ST : EBK61012601, 2ND : 0TRDI80002A
Q1002	1ST : EBK60752501, 2ND : EBK61011501

Wireless power

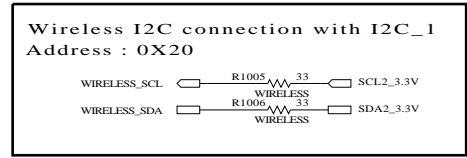
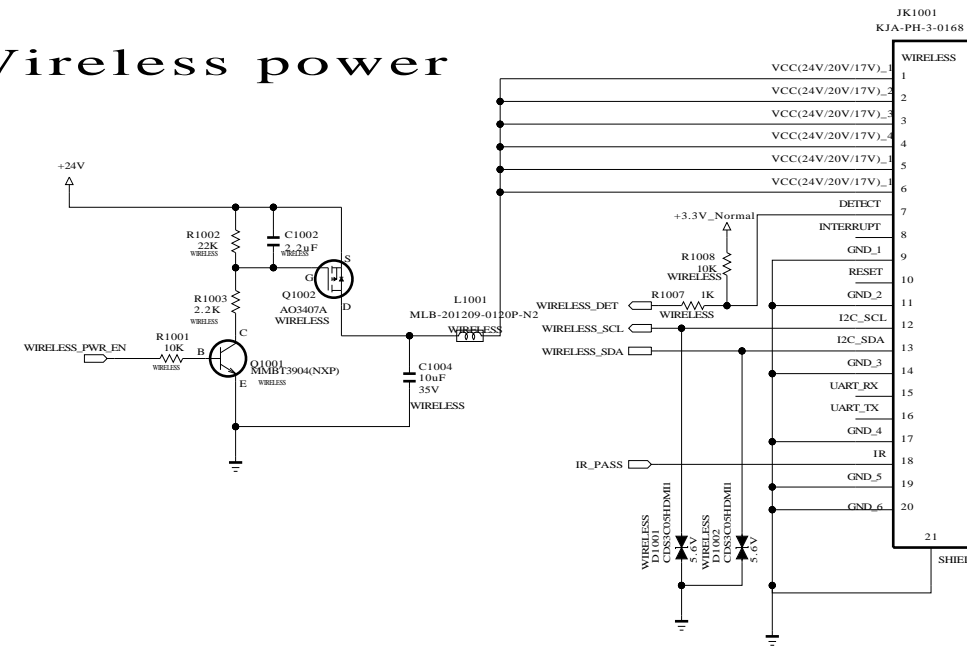

THE SYMBOL MARK OF THIS SCHEMATIC DIAGRAM INCORPORATES SPECIAL FEATURES IMPORTANT FOR PROTECTION FROM X-RADIATION, FILRE AND ELECTRICAL SHOCK HAZARDS, WHEN SERVICING IF IS ESSENTIAL THAT ONLY MANUFACTURES SPECIFIED PARTS BE USED FOR THE CRITICAL COMPONENTS IN THE SYMBOL MARK OF THE SCHEMATIC.

SECRET
LGElectronics



MODEL	BCM35230	DATE	
BLOCK	WIRELESS	SHEET	10 / 50

CVBS 1 PHONE JACK



CVBS2 REAR JACK

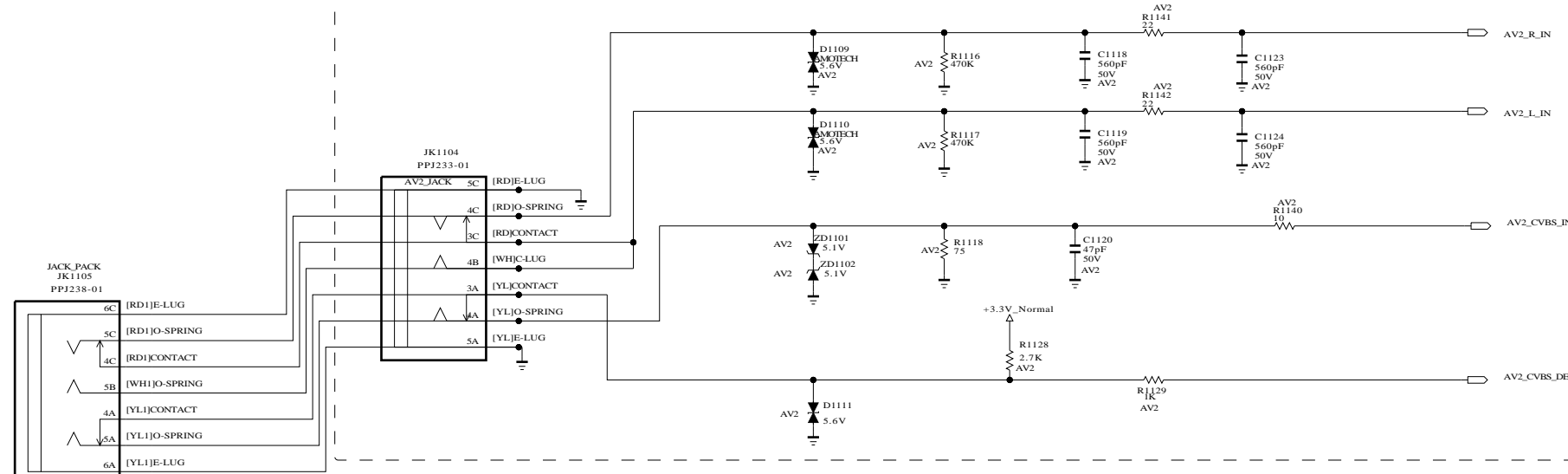

COMP2 REAR JACK

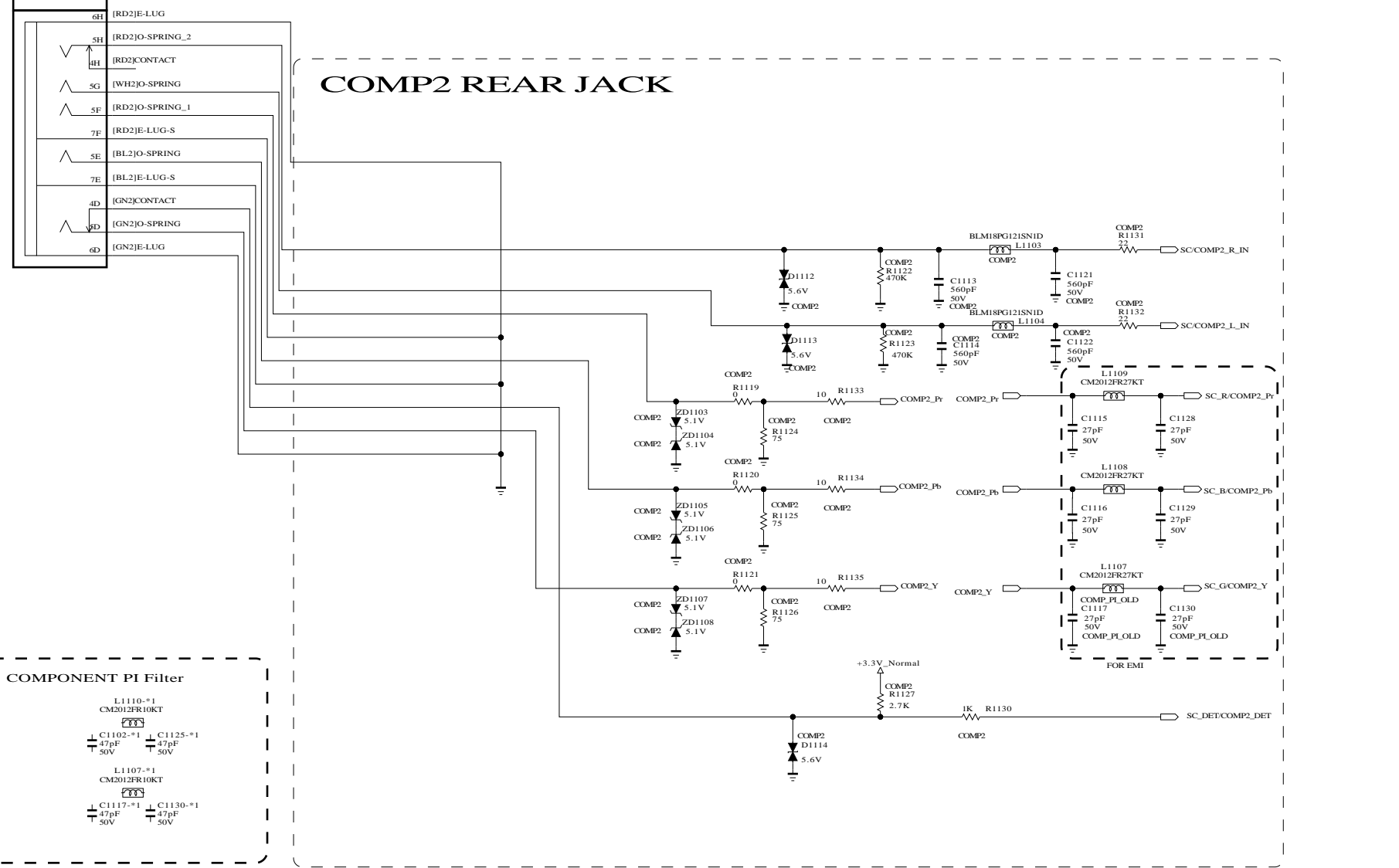

COMPONENT 1 PHONE JACK

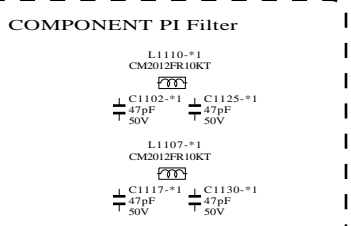
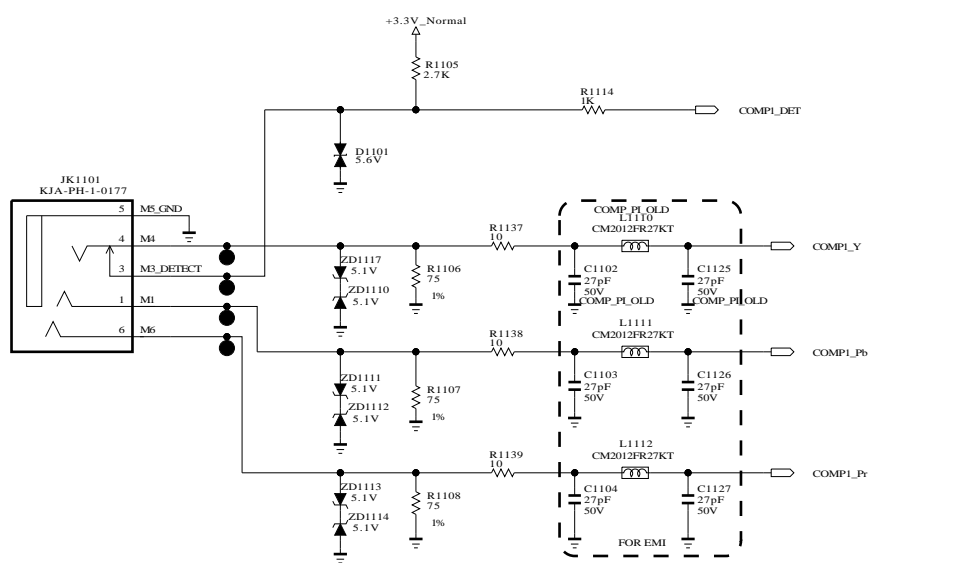

THE SYMBOL MARK OF THIS SCHEMATIC DIAGRAM INCORPORATES SPECIAL FEATURES IMPORTANT FOR PROTECTION FROM X-RADIATION, FILRE AND ELECTRICAL SHOCK HAZARDS, WHEN SERVICING IF IS ESSENTIAL THAT ONLY MANUFACTURES SPECIFIED PARTS BE USED FOR THE CRITICAL COMPONENTS IN THE SYMBOL MARK OF THE SCHEMATIC.

SECRET
LGElectronics



MODEL	BCM35230	DATE	
BLOCK	COMP/AV	SHEET	11 / 50

USB_WIFI

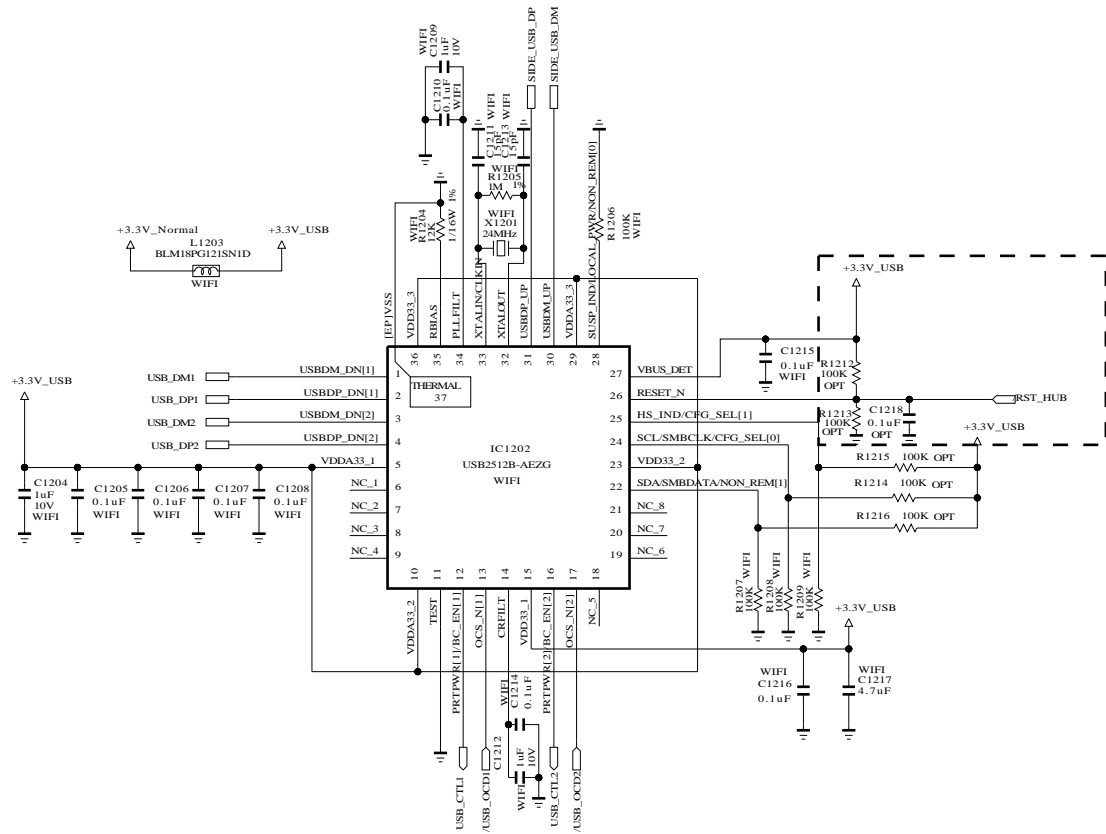
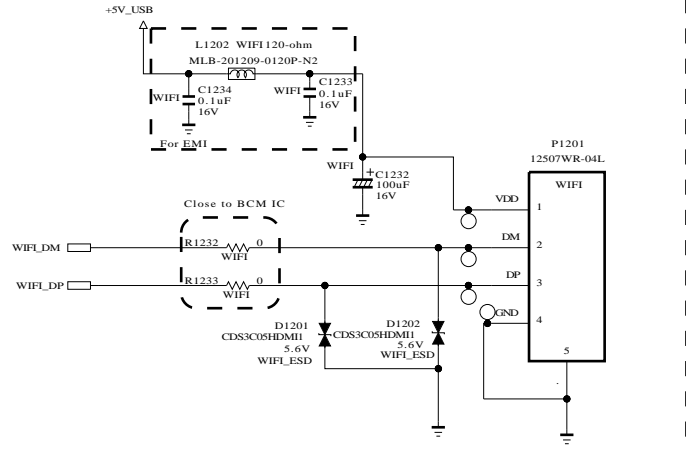

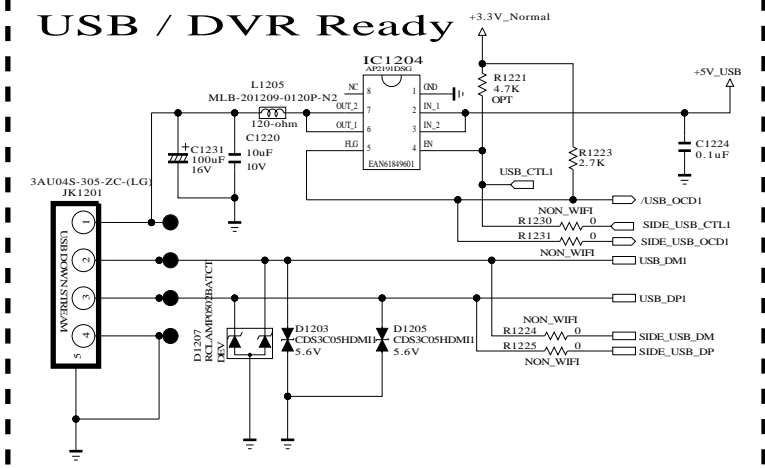

DUAL COMPONENT	
D1201,D1202 D1203,D1204 D1205,D1206	1ST : EAH42720601 2ND : EAH60994401

USB / DVR Ready

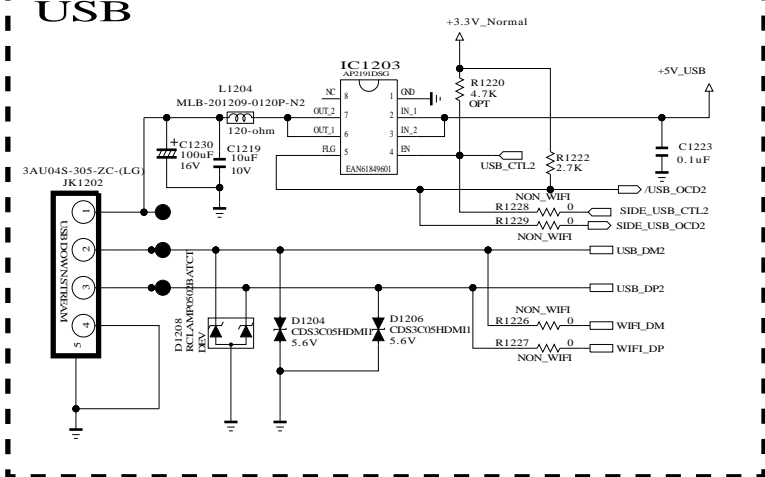

USB



THE  SYMBOL MARK OF THIS SCHEMATIC DIAGRAM INCORPORATES SPECIAL FEATURES IMPORTANT FOR PROTECTION FROM X-RADIATION. FILRE AND ELECTRICAL SHOCK HAZARDS, WHEN SERVICING IF IS ESSENTIAL THAT ONLY MANUFACTURES SPECIFIED PARTS BE USED FOR THE CRITICAL COMPONENTS IN THE  SYMBOL MARK OF THE SCHEMATIC.

SECRET	 LG ELECTRONICS
LGElectronics	

MODEL	BCM35230	DATE	
BLOCK	USB + WIFI	SHEET	12 /

TI solution M_REMOTE OPTION

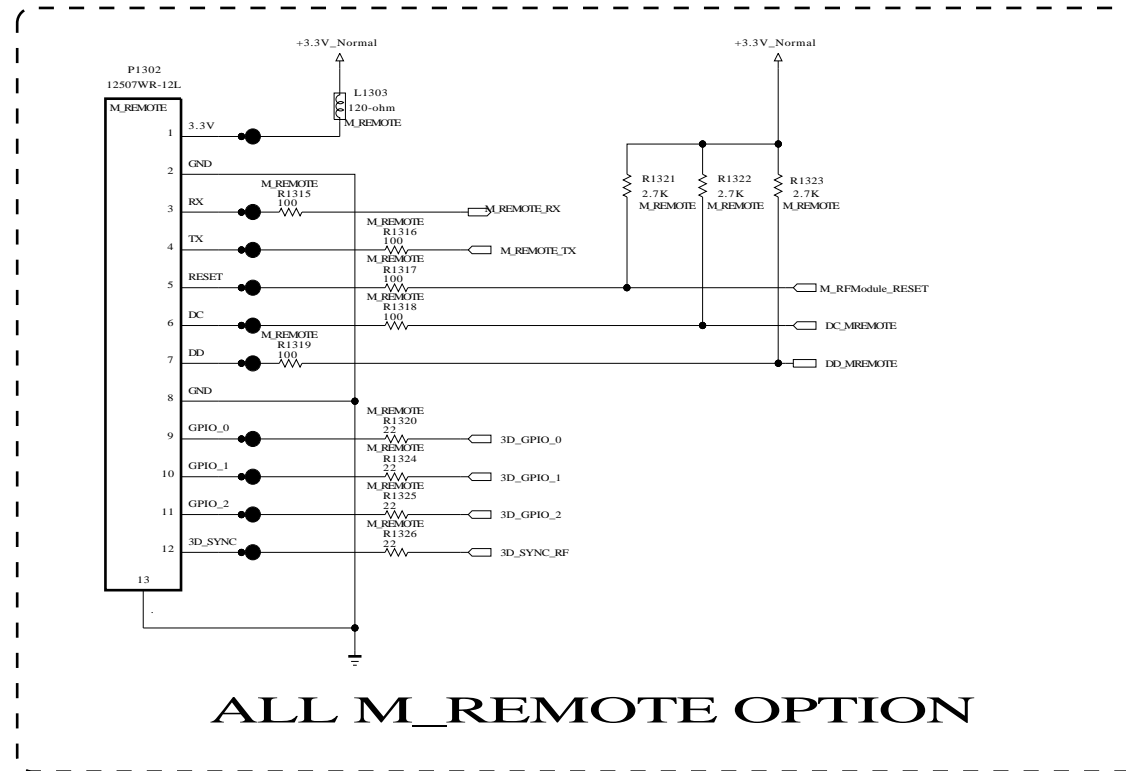

THE SYMBOL MARK OF THIS SCHEMATIC DIAGRAM INCORPORATES SPECIAL FEATURES IMPORTANT FOR PROTECTION FROM X-RADIATION. FILRE AND ELECTRICAL SHOCK HAZARDS, WHEN SERVICING IF IS ESSENTIAL THAT ONLY MANUFACTURES SPECIFIED PARTS BE USED FOR THE CRITICAL COMPONENTS IN THE SYMBOL MARK OF THE SCHEMATIC.

SECRET
LGElectronics

LG ELECTRONICS

MODEL	BCM35230	DATE	
BLOCK	M_REMOCON	SHEET	13 / 50

Ethernet Block

DUAL COMPONENT	
D1401,D1402 D1403,D1404 D1405,D1406	1ST : EAH42720601 2ND : EAH60994401

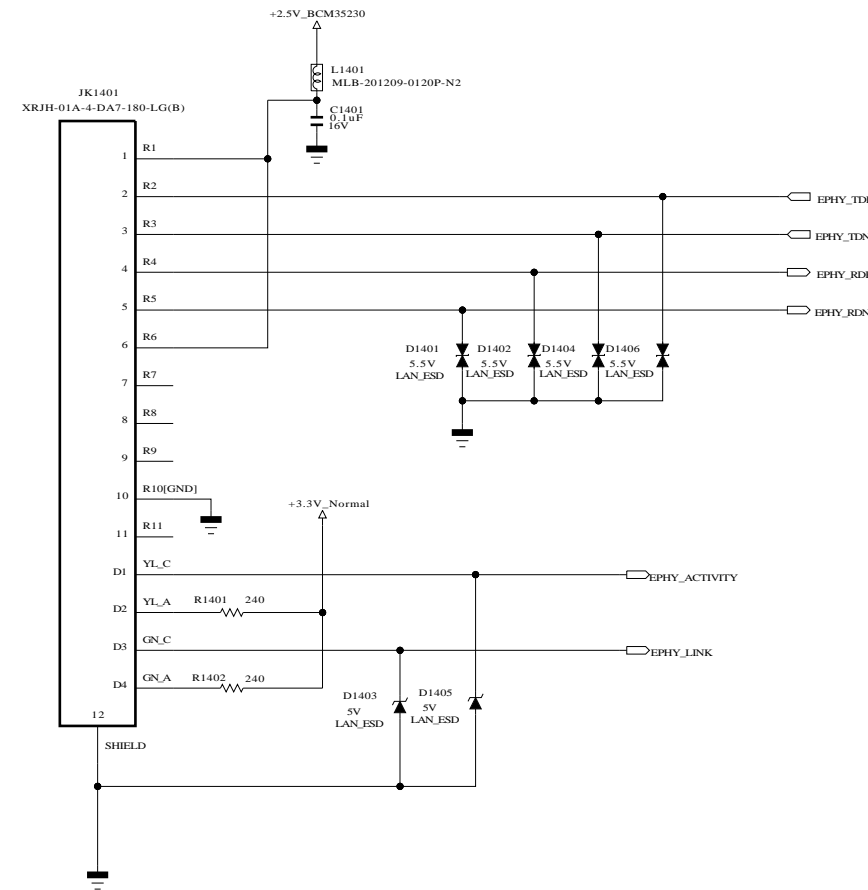

THE SYMBOL MARK OF THIS SCHEMATIC DIAGRAM INCORPORATES SPECIAL FEATURES IMPORTANT FOR PROTECTION FROM X-RADIATION, FILRE AND ELECTRICAL SHOCK HAZARDS, WHEN SERVICING IF IS ESSENTIAL THAT ONLY MANUFACTURES SPECIFIED PARTS BE USED FOR THE CRITICAL COMPONENTS IN THE SYMBOL MARK OF THE SCHEMATIC.

SECRET
LGElectronics



MODEL	BCM35230	DATE	
BLOCK	ETHERNET	SHEET	14 / 50

NON CI

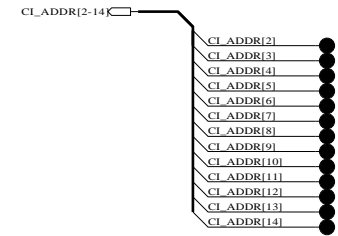
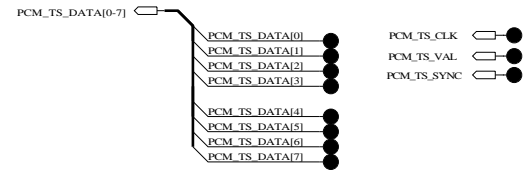
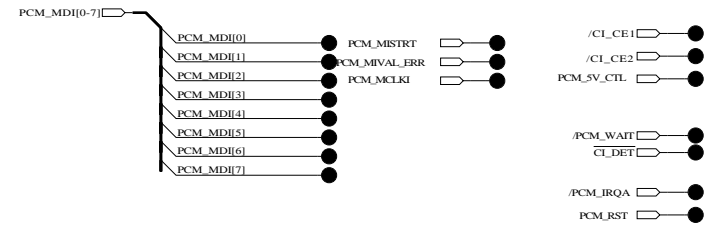

THE SYMBOL MARK OF THIS SCHEMATIC DIAGRAM INCORPORATES SPECIAL FEATURES IMPORTANT FOR PROTECTION FROM X-RADIATION. FILRE AND ELECTRICAL SHOCK HAZARDS, WHEN SERVICING IF IS ESSENTIAL THAT ONLY MANUFACTURES SPECIFIED PARTS BE USED FOR THE CRITICAL COMPONENTS IN THE SYMBOL MARK OF THE SCHEMATIC.

SECRET
LGElectronics



MODEL	BCM35230	DATE	
BLOCK	NON CI	SHEET	20 / 50

LVDS

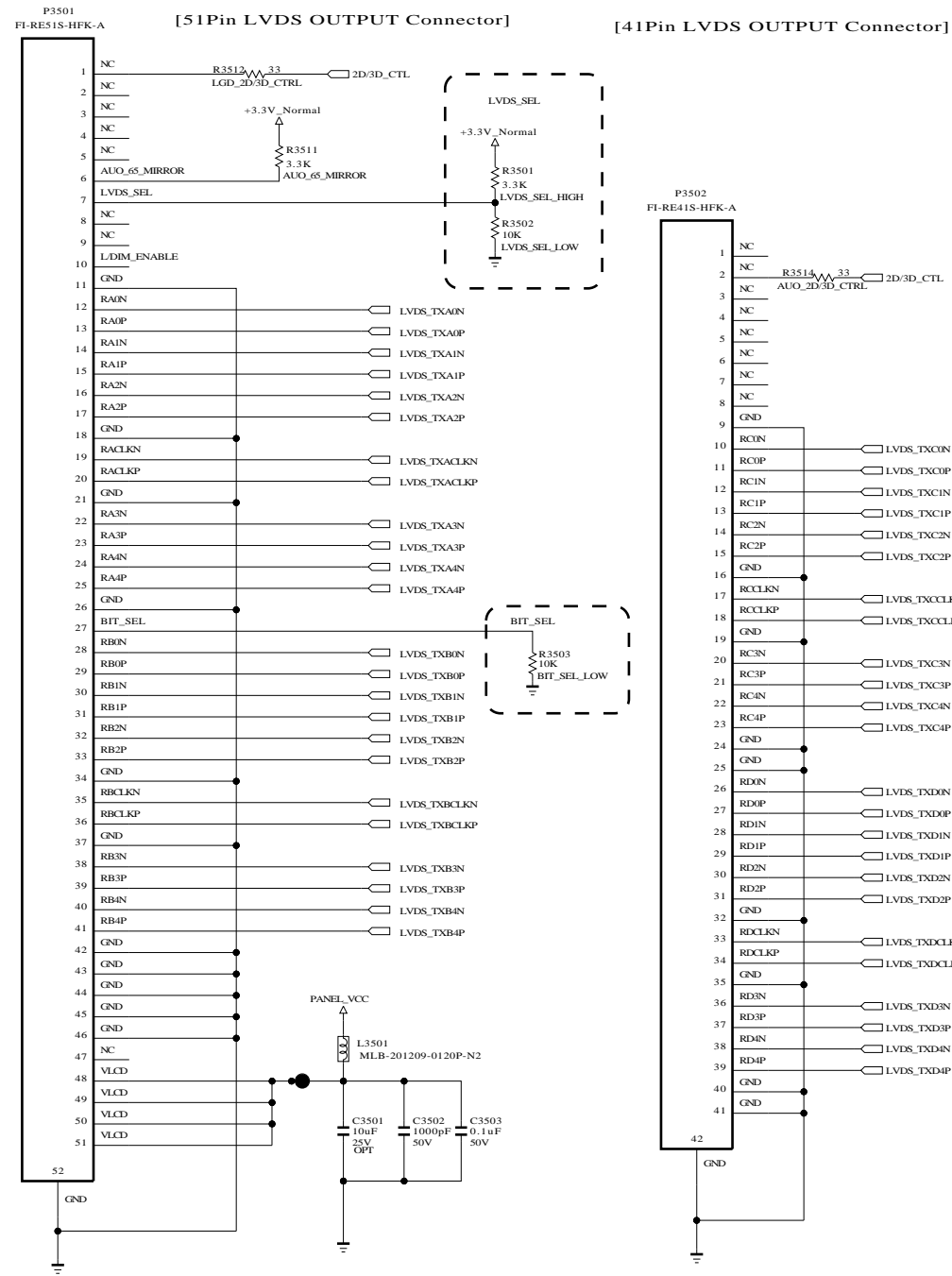

LOCAL DIMMING

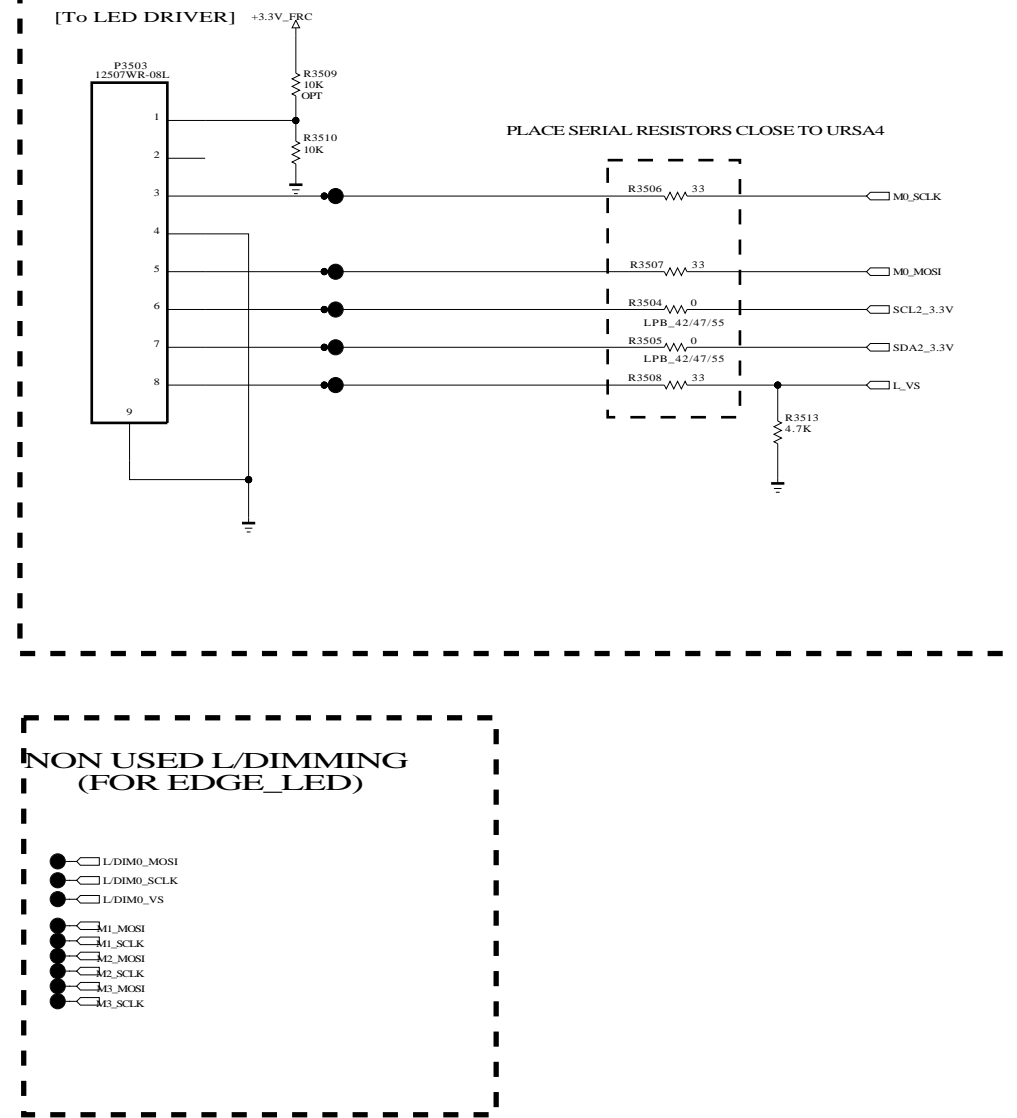

THE SYMBOL MARK OF THIS SCHEMATIC DIAGRAM INCORPORATES SPECIAL FEATURES IMPORTANT FOR PROTECTION FROM X-RADIATION. FILRE AND ELECTRICAL SHOCK HAZARDS, WHEN SERVICING IF IS ESSENTIAL THAT ONLY MANUFACTURES SPECIFIED PARTS BE USED FOR THE CRITICAL COMPONENTS IN THE SYMBOL MARK OF THE SCHEMATIC.

TAS5727

DUAL COMPONENT	
Q1701	1ST : 0TRIY80001A 2ND : 0TR387500AA

MAIN

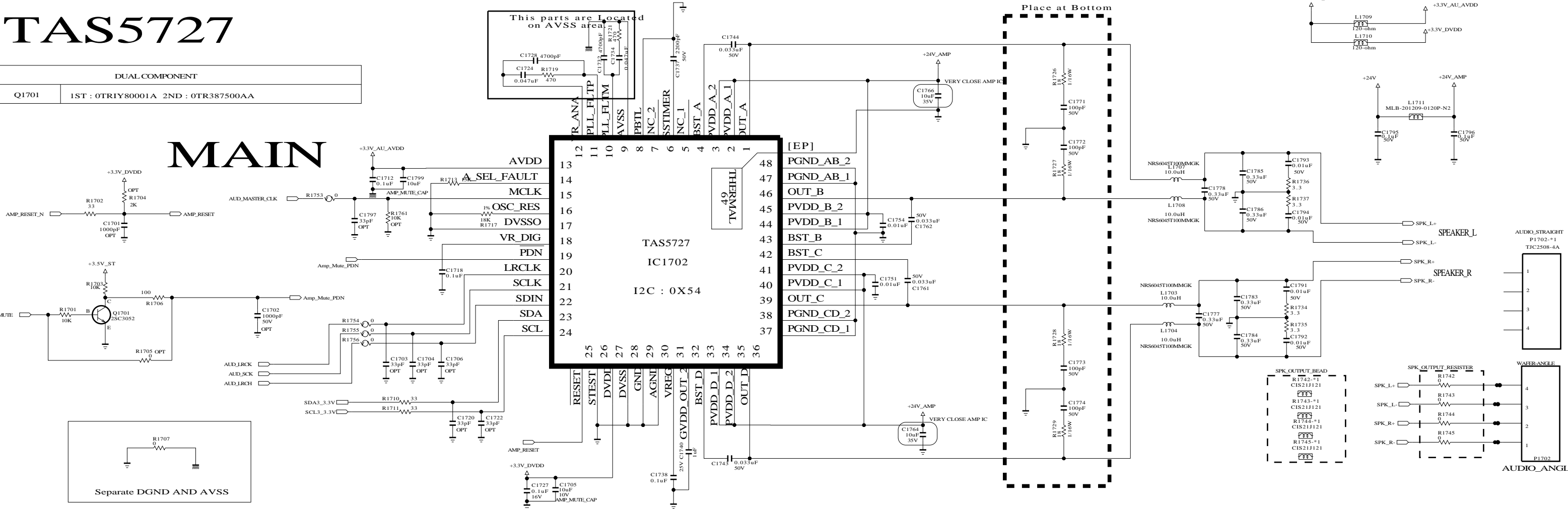

WOOFER

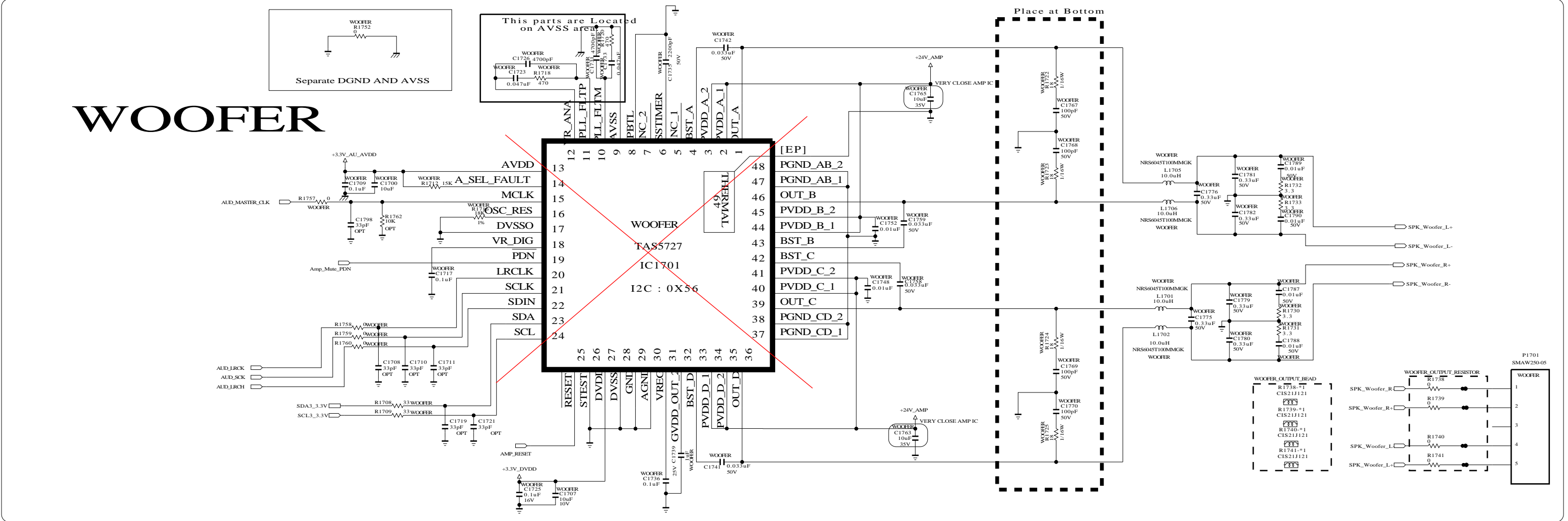

THE SYMBOL MARK OF THIS SCHEMATIC DIAGRAM INCORPORATES SPECIAL FEATURES IMPORTANT FOR PROTECTION FROM X-RADIATION. FILRE AND ELECTRICAL SHOCK HAZARDS, WHEN SERVICING IF IS ESSENTIAL THAT ONLY MANUFACTURES SPECIFIED PARTS BE USED FOR THE CRITICAL COMPONENTS IN THE SYMBOL MARK OF THE SCHEMATIC.

SECRET
LGElectronics



MODEL	BCM35230	DATE	
BLOCK	AUDIO[TI]	SHEET	17 / 50

NON_CHB & CHB TUNER (KOR/USA)

DUAL COMPONENT	
IC2102	1ST : EAN61829801, 2ND : EAN544289201
IC2103	1ST : EAN61507501, 2ND : EAN54428101

NON_CHB_SANYO_TUNER

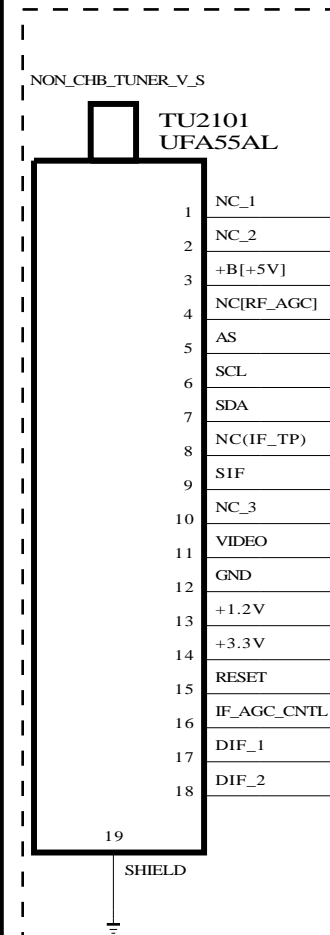

CHB_TUNER

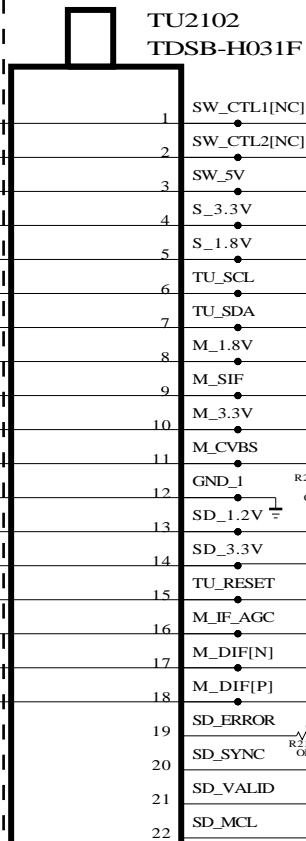

NON_CHB_TUNER_HS

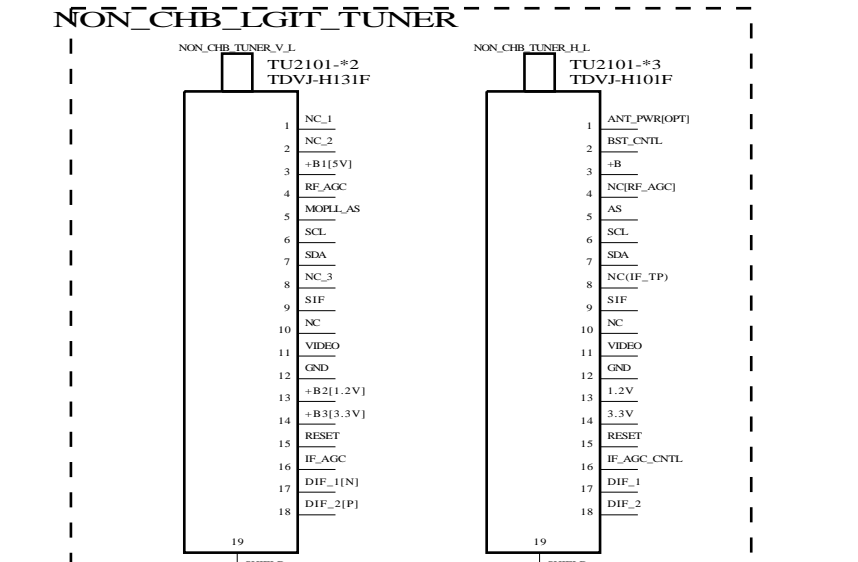
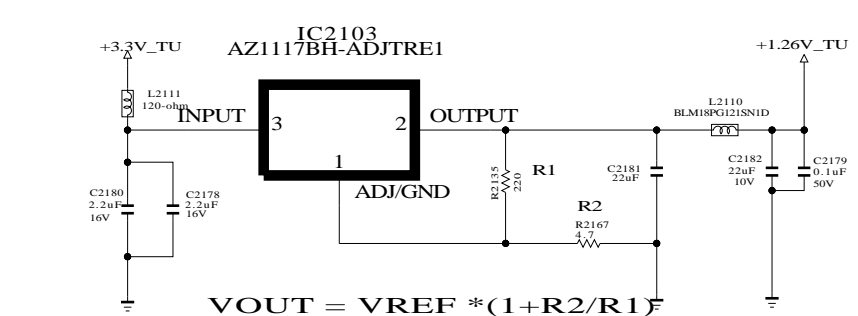
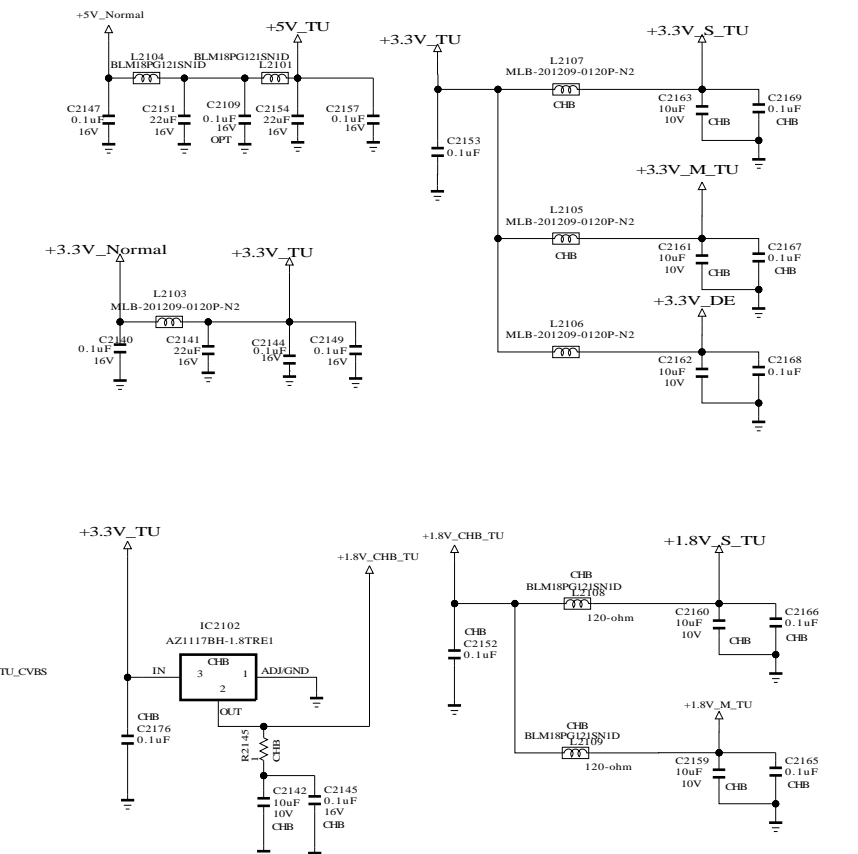
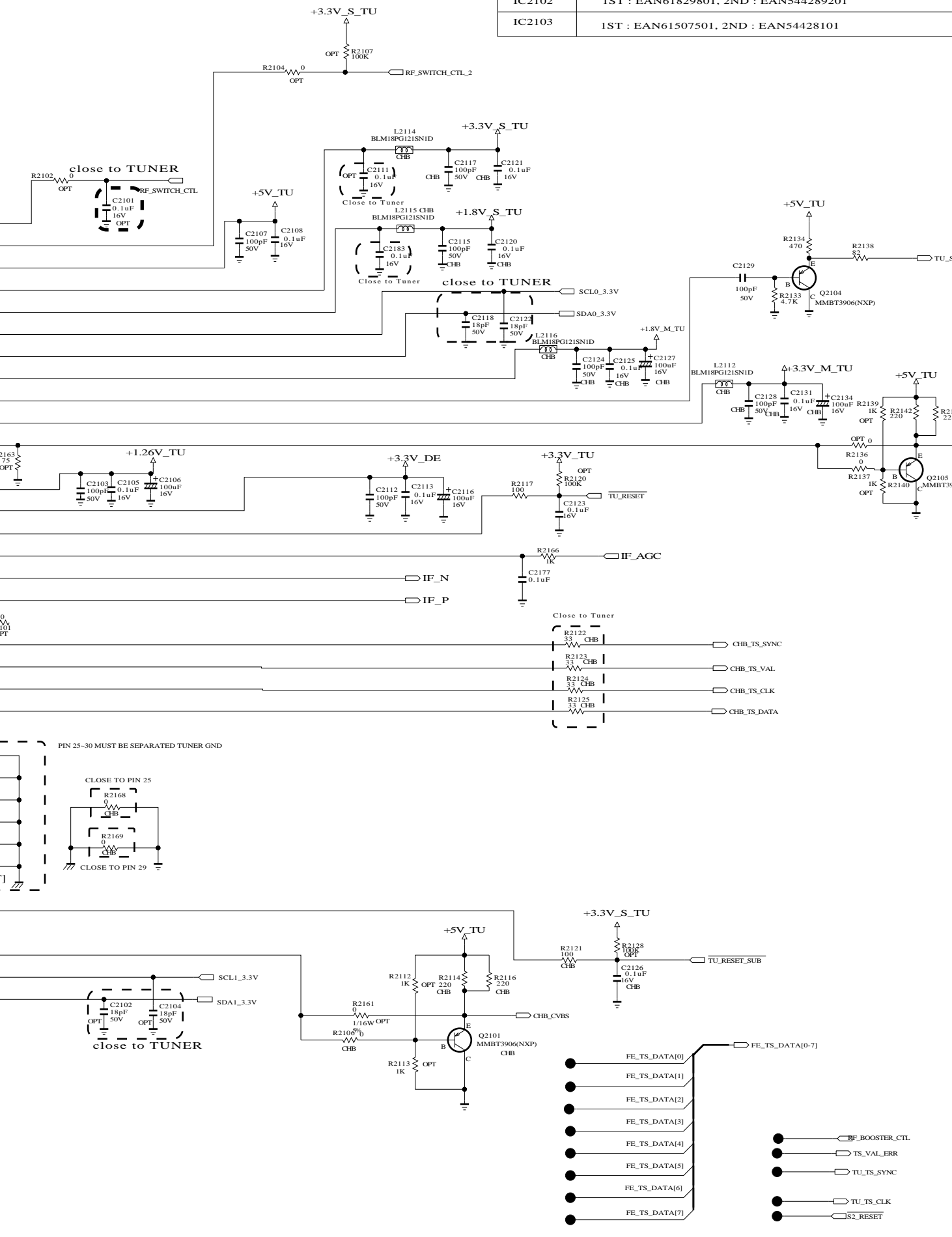
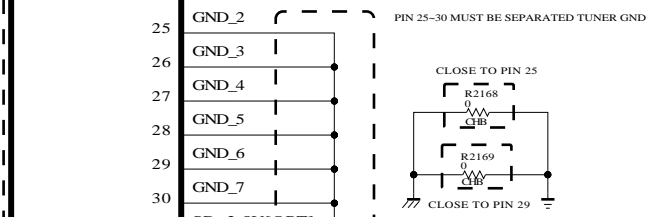
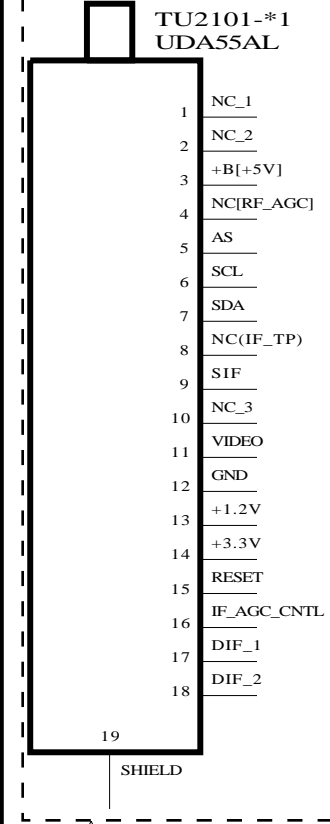

THE SYMBOL MARK OF THIS SCHEMATIC DIAGRAM INCORPORATES SPECIAL FEATURES IMPORTANT FOR PROTECTION FROM X-RADIATION. FILRE AND ELECTRICAL SHOCK HAZARDS, WHEN SERVICING IF IS ESSENTIAL THAT ONLY MANUFACTURES SPECIFIED PARTS BE USED FOR THE CRITICAL COMPONENTS IN THE SYMBOL MARK OF THE SCHEMATIC.

SECRET
LGElectronics



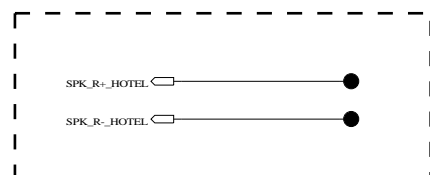

MODEL	BCM35230	DATE	
BLOCK	ATSC_TUNER	SHEET	21 / 50

NON CHINA HOTEL



- JP3001
- JP3002
- JP3003
- JP3004
- JP3005
- JP3006

THE  SYMBOL MARK OF THIS SCHEMATIC DIAGRAM INCORPORATES SPECIAL FEATURES IMPORTANT FOR PROTECTION FROM X-RADIATION. FILRE AND ELECTRICAL SHOCK HAZARDS, WHEN SERVICING IF IS ESSENTIAL THAT ONLY MANUFACTURES SPECIFIED PARTS BE USED FOR THE CRITICAL COMPONENTS IN THE  SYMBOL MARK OF THE SCHEMATIC.

SECRET
LGElectronics



MODEL	BCM35230	DATE	
BLOCK	NON CHINA HOTEL	SHEET	30 / 50

CHANNEL BROWSER

DUAL COMPONENT	
IC2703	1ST : EAN61829801 2ND : EAN54428201

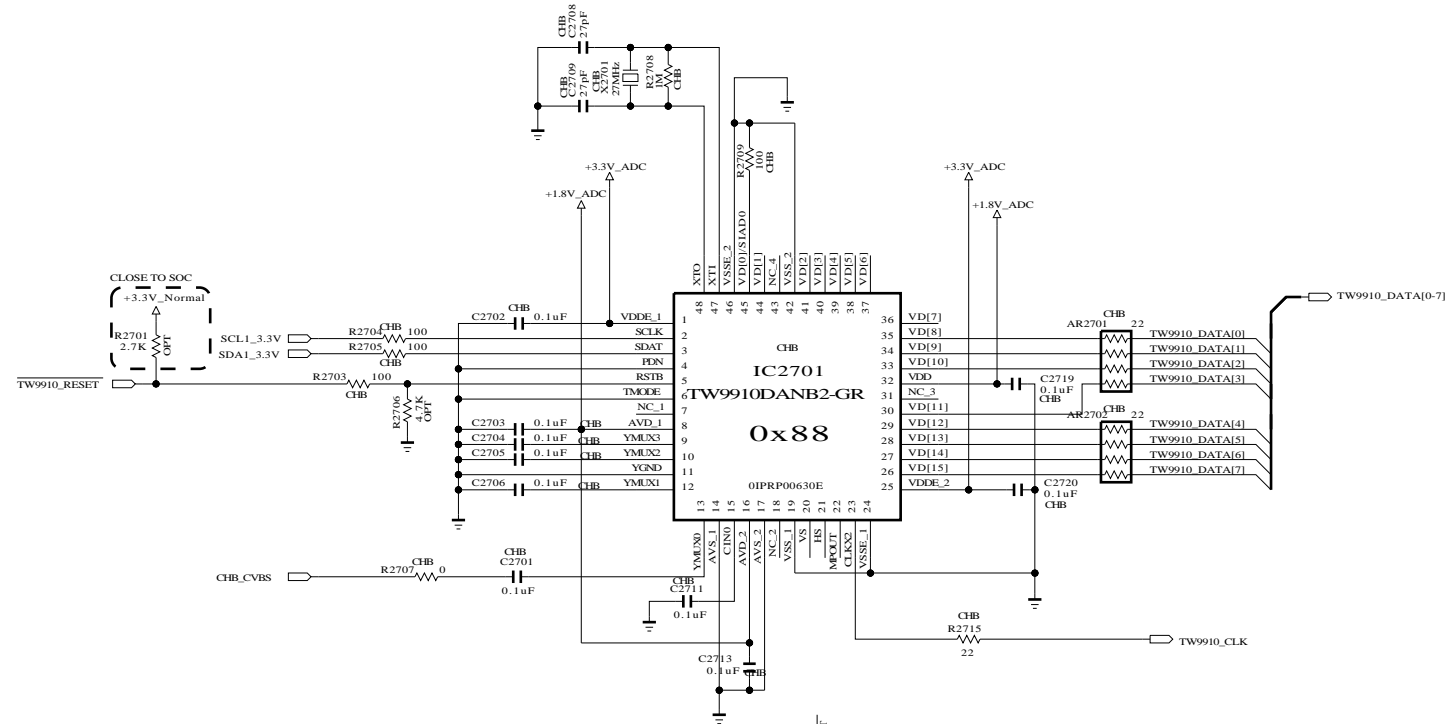

CHB OPTION

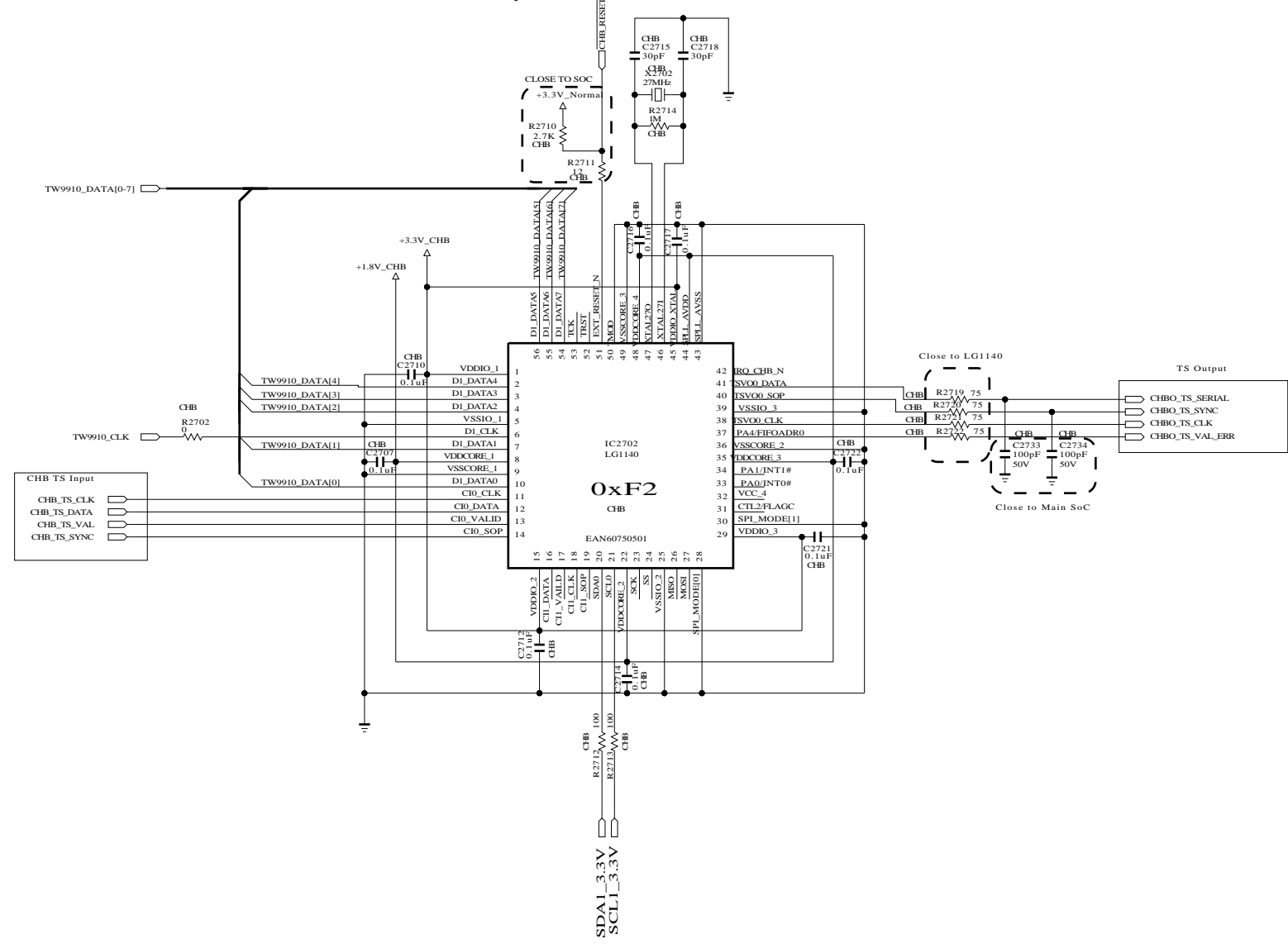
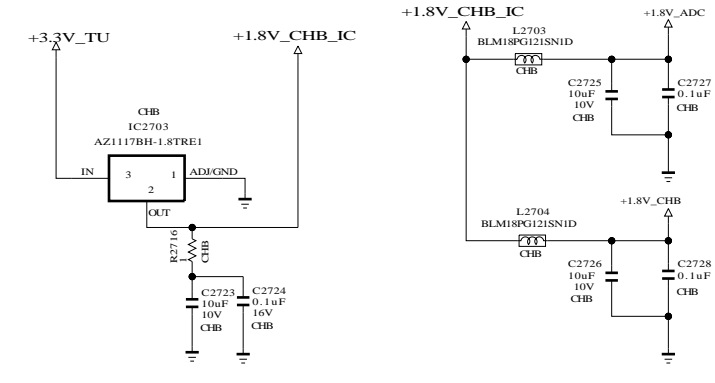

THE SYMBOL MARK OF THIS SCHEMATIC DIAGRAM INCORPORATES SPECIAL FEATURES IMPORTANT FOR PROTECTION FROM X-RADIATION. FILRE AND ELECTRICAL SHOCK HAZARDS, WHEN SERVICING IF IS ESSENTIAL THAT ONLY MANUFACTURES SPECIFIED PARTS BE USED FOR THE CRITICAL COMPONENTS IN THE SYMBOL MARK OF THE SCHEMATIC.

SECRET
LGElectronics



MODEL	BCM35230	DATE	
BLOCK	CHB	SHEET	27 / 50

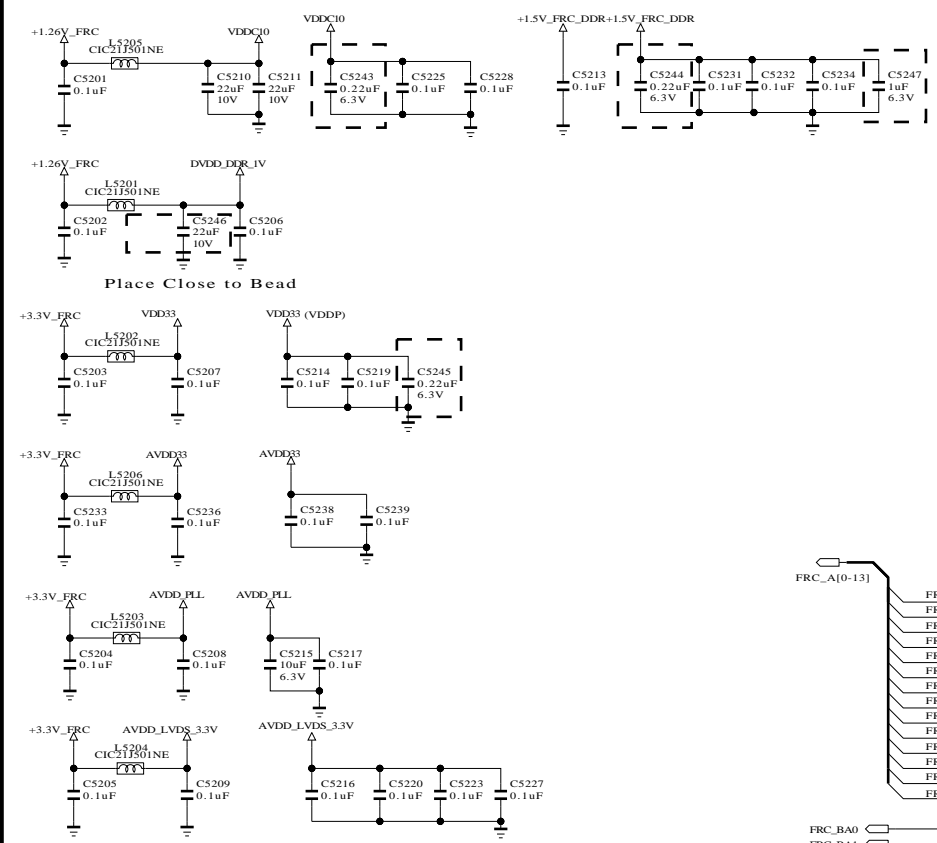

PLACE TERMINATION RESISTORS CLOSE TO URSA5

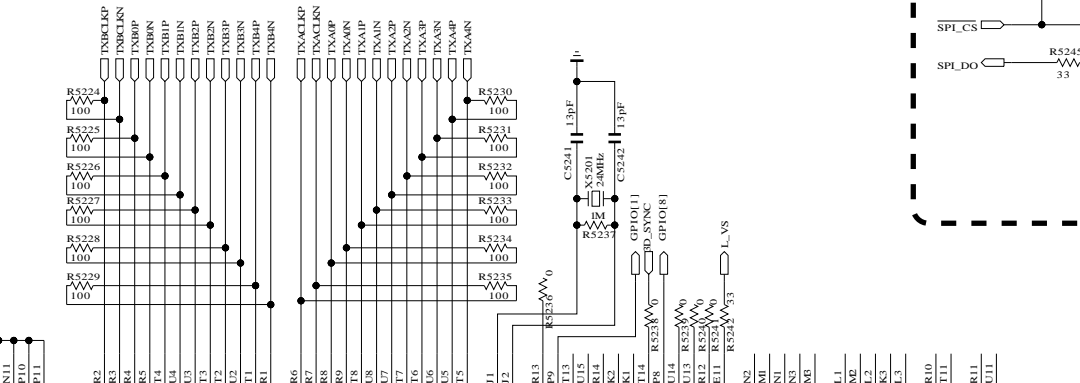

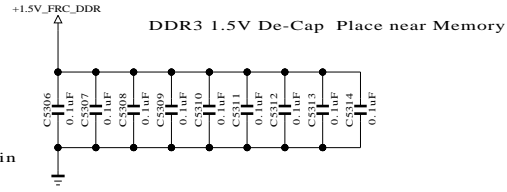
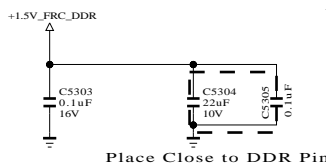
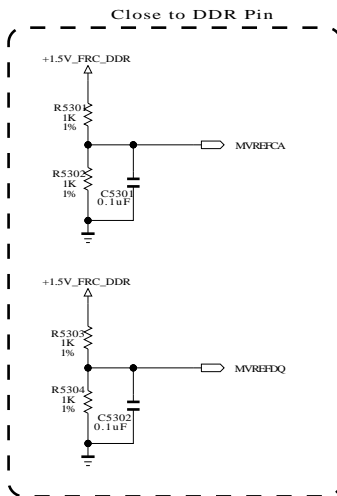

Place the serial damping resist in the middle of DRAM pattern

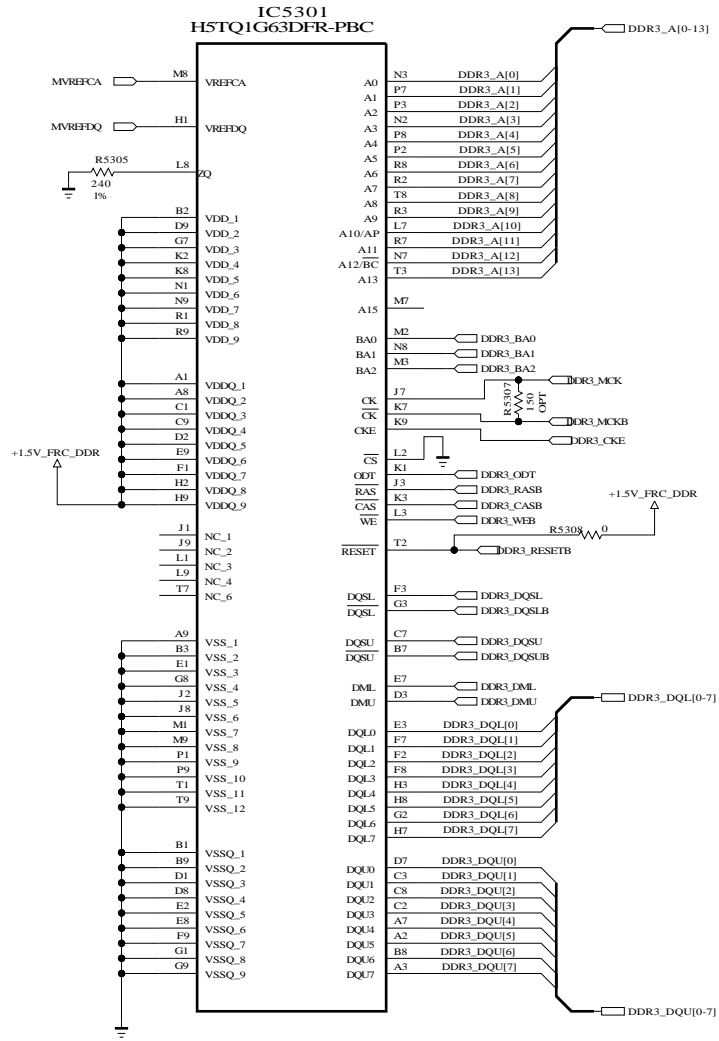
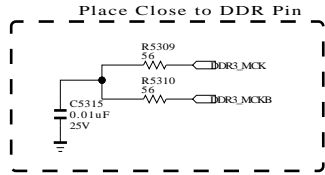
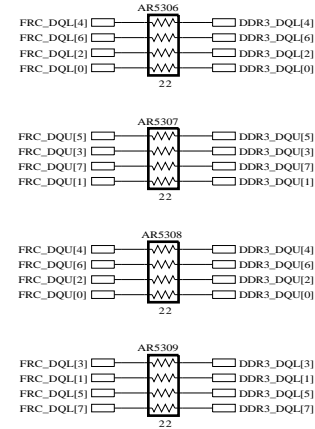
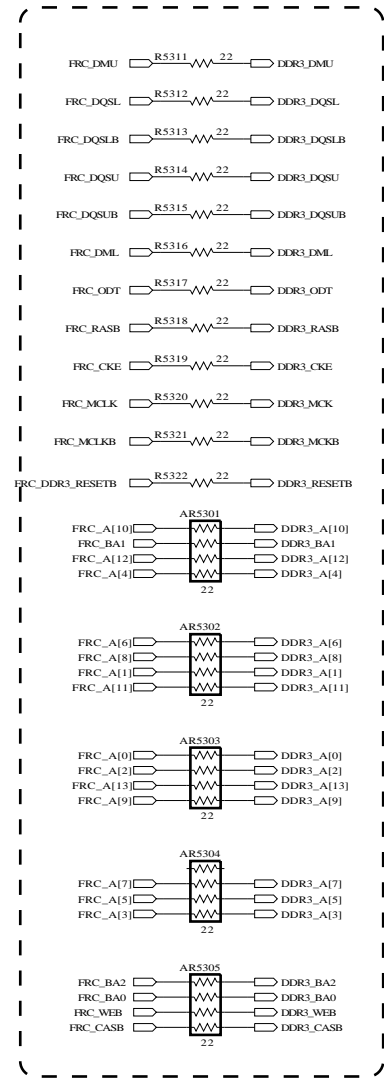

THE SYMBOL MARK OF THIS SCHEMATIC DIAGRAM INCORPORATES SPECIAL FEATURES IMPORTANT FOR PROTECTION FROM X-RADIATION. FILRE AND ELECTRICAL SHOCK HAZARDS. WHEN SERVICING IF IS ESSENTIAL THAT ONLY MANUFACTURES SPECIFIED PARTS BE USED FOR THE CRITICAL COMPONENTS IN THE SYMBOL MARK OF THE SCHEMATIC.

SECRET
LG Electronics

MODEL	MStar URSA5	DATE	2010. 08.18
BLOCK	DDR3 4Mbit	SHEET	53 / 55

CORE +1.26V_FRC

TYPICAL 980mA

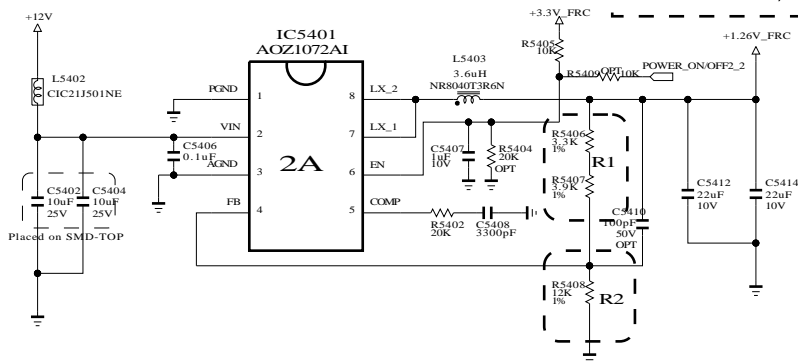

$$V_{out} = (1 + R1/R2) * 0.8$$

+1.5V_FRC

TYPICAL 350mA

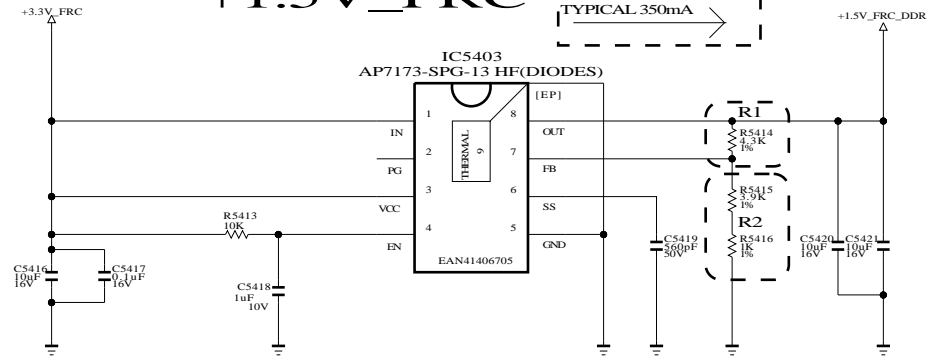

$$V_{out} = 0.6 * (1 + R1/R2)$$



+1.5V of DDR&URSA5 uses same power line

+3.3V_FRC

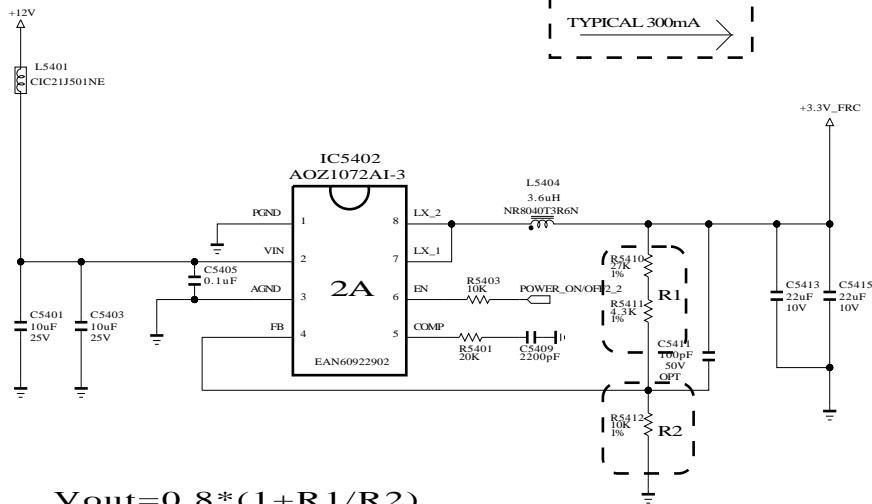
TYPICAL 300mA



$$V_{out} = 0.8 * (1 + R1/R2)$$

THE  SYMBOL MARK OF THIS SCHEMATIC DIAGRAM INCORPORATES SPECIAL FEATURES IMPORTANT FOR PROTECTION FROM X-RADIATION. FILRE AND ELECTRICAL SHOCK HAZARDS. WHEN SERVICING IF IS ESSENTIAL THAT ONLY MANUFACTURES SPECIFIED PARTS BE USED FOR THE CRITICAL COMPONENTS IN THE  SYMBOL MARK OF THE SCHEMATIC.

SECRET

LG Electronics

 LG ELECTRONICS

MODEL	MStar URSA5	DATE	2010. 08.18
BLOCK	URSA5 Power Block	SHEET	54 / 55

SMD GASKET

SMD GASKET 4.5T

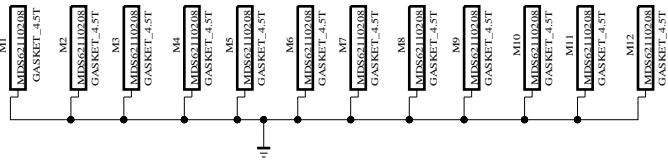

SMD GASKET 5.0T

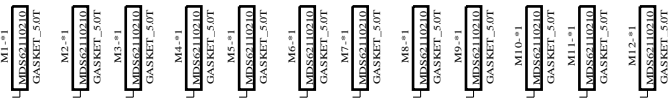

SMD GASKET 5.5T



SMD GASKET 6.5T



SMD GASKET 7.5T

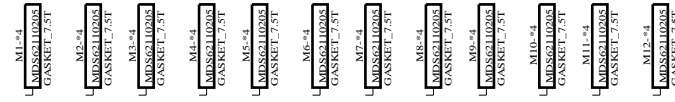

SMD GASKET 8.5T



SMD GASKET 9.5T

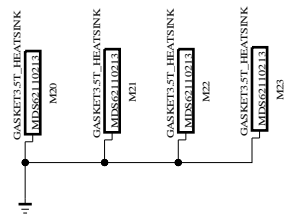

THE SYMBOL MARK OF THIS SCHEMATIC DIAGRAM INCORPORATES SPECIAL FEATURES IMPORTANT FOR PROTECTION FROM X-RADIATION, FILRE AND ELECTRICAL SHOCK HAZARDS, WHEN SERVICING IF IS ESSENTIAL THAT ONLY MANUFACTURES SPECIFIED PARTS BE USED FOR THE CRITICAL COMPONENTS IN THE SYMBOL MARK OF THE SCHEMATIC.

SECRET	
LG Electronics	

MODEL	BCM35230	DATE	2010. 09. 18
BLOCK	SMD GASKET	SHEET	56 / 56

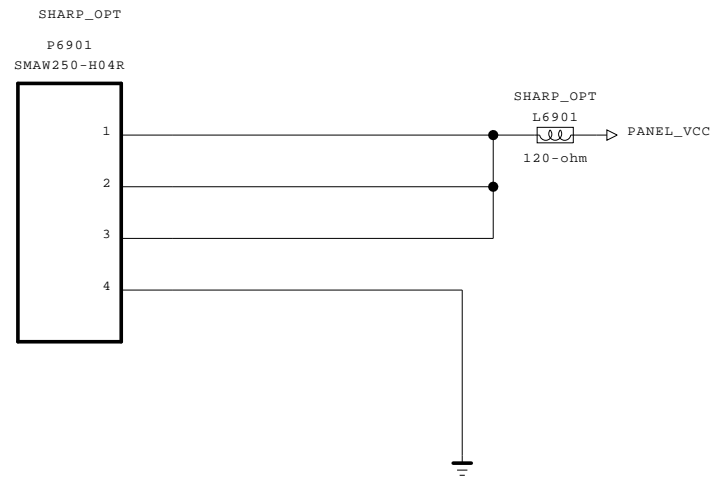

THE ⚠ SYMBOL MARK OF THIS SCHEMATIC DIAGRAM INCORPORATES SPECIAL FEATURES IMPORTANT FOR PROTECTION FROM X-RADIATION. FILRE AND ELECTRICAL SHOCK HAZARDS, WHEN SERVICING IF IS ESSENTIAL THAT ONLY MANUFACTURES SPECIFIED PARTS BE USED FOR THE CRITICAL COMPONENTS IN THE ⚠ SYMBOL MARK OF THE SCHEMATIC.

SECRET
LGElectronics

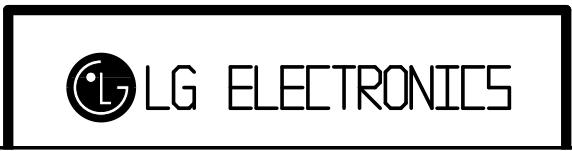

MODEL		DATE	
BLOCK		SHEET	/