

Phase Control Thyristors

Features

1. 495 PT series Thyristors are deigned for various power controls
2. Voltage rating up to 800 V.
3. Typical application
 - DC motor control
 - Controlled DC power supplies
 - AC controllers

Ordering code

495	PT	xx	B	0
(1)	(2)	(3)	(4)	(5)

- (1) Maximum average on-state current , A
- (2) For Phase Control Thyristor
- (3) Voltage code , code x 100 = V_{RRM} / V_{DRM}
- (4) package style : A , B , C , D ,E for Disc Type
- (5) Terminal types
0 - for eyelet

B TYPE

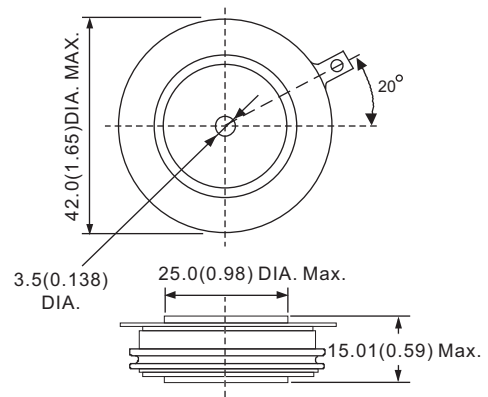

All dimensions in millimeters (inches)

Electrical Characteristics

Symbol	Parameter	Condition	Value			Unit
			Min.	Type	Max.	
$I_T(AV)$	Mean on-state current	180° half sine wave , 50Hz Double side cooled , $T_C = 55^\circ C$			495	A
$I_T(RMS)$	Max. RMS on-state current	Double side cooled , $T_C = 25^\circ C$			1032	A
V_{RRM} V_{DRM}	Repetitive peak off-state voltage Repetitive peak reverse voltage	$V_{DRM} \& V_{RRM} \ t_p = 10ms$ $V_{DsM} \& V_{RsM} = V_{DRM} \& V_{RRM} + 100V$	200		800	V
I_{TSM}	Surge on-state current	10 ms half sine wave			6000	A
I_t^2	For fusing coordination	$V_R = 0.6V_{RRM}$			218	Ka ² s
$V_{T(TO)}$	Threshold voltage				0.85	V
r_t	On-state slope resistance				0.53	mΩ
V_{TM}	Max. Forward voltage drop	$I_{TM} = 900A , F = 8.0KN$			1.26	V
I_H	Holding current	$V_A = 12V , I_A = 1A$			600	mA
d_i/dt	Critical rate of rise of turned-on current	Gate drive 20V , 20 Ω , $t_r \leq 0.5 \mu s$			1000	A/μs
t_q	Typical turn-off time	$I_{TM} = 400A , d_v/dt = 30V/\mu s$ $d_iRR/dt = -10 A/\mu s$			150	μs
d_v/dt	Critical rate of rise of off-state voltage	$V_{DM} = 0.67 V_{DRM}$			1000	V/μs
P_G	Max. average gate power	Square wavepulse width 100 μs			2	W
P_{GM}	Max. peak gate power square				30	W
I_{GT}	Gate trigger current	$V_A = 12V , I_A = 1A$			150	mA
V_{GT}	Gate trigger voltage				3	V
T_{stg}	Storage temperature		- 40		150	°C
T_j	Max. operating temperature range		- 40		125	°C
$R_{th(j-h)}$	Thermal resistance(junction to heatsink)	Double side cooled , clamping force 8.0 KN			0.21	°C/W
F_m	Mounting force		3.3		5.5	KN
W_t	Approximate weight				70	g

Fig. 1

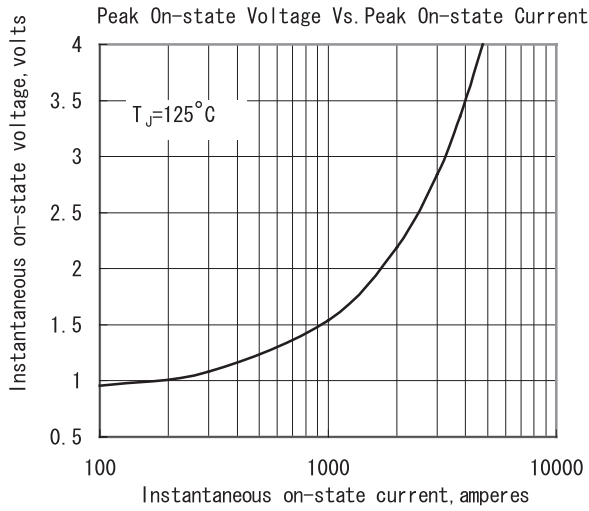

Fig. 2

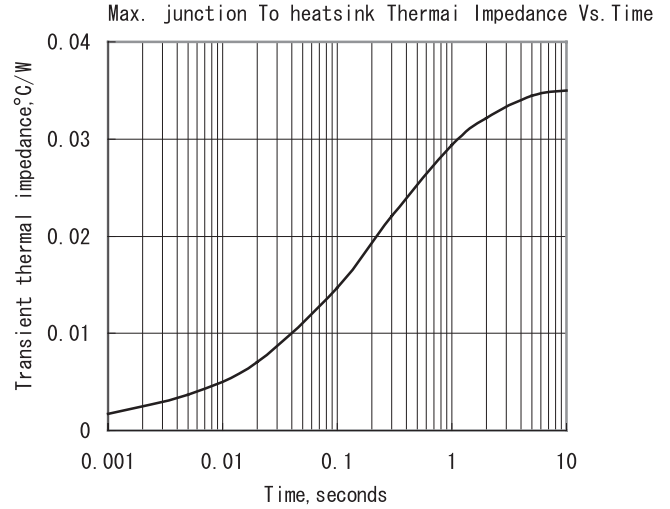

Fig. 3

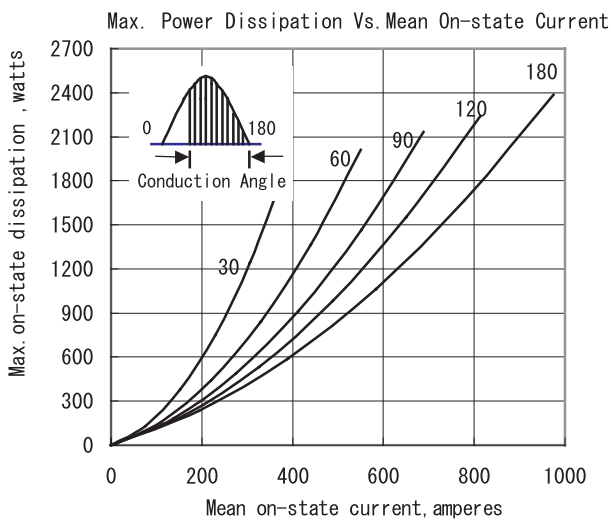

Fig. 4

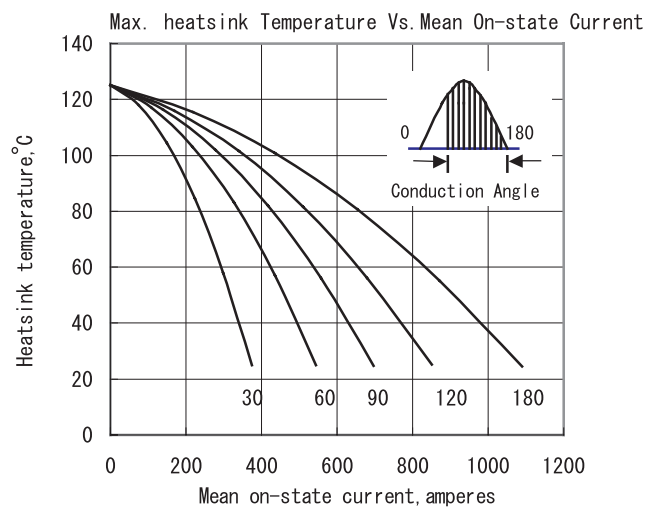

Fig. 5

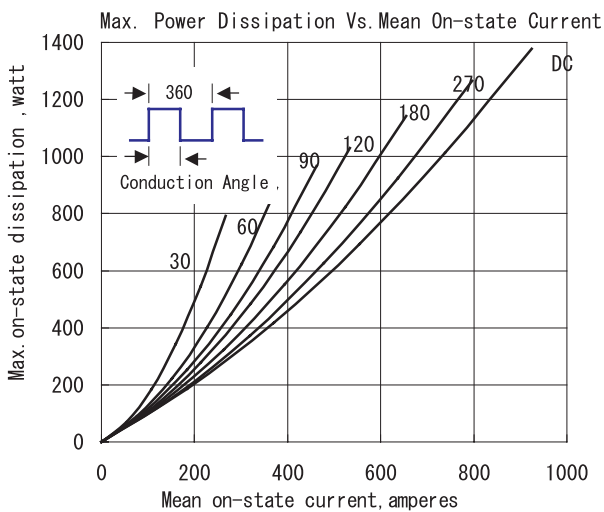

Fig. 6

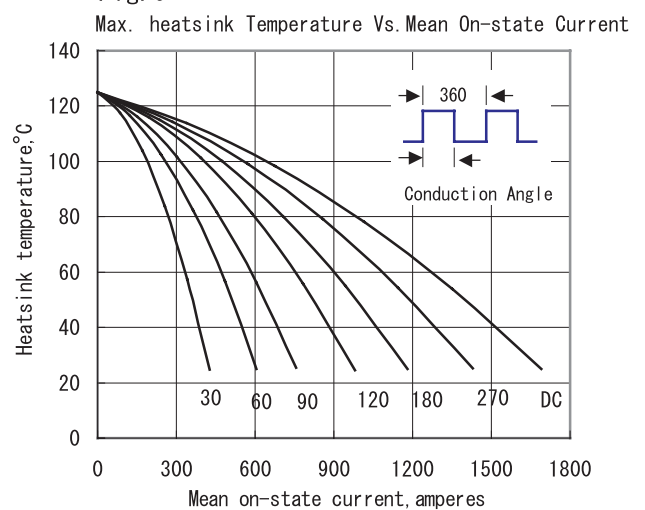

Fig. 7

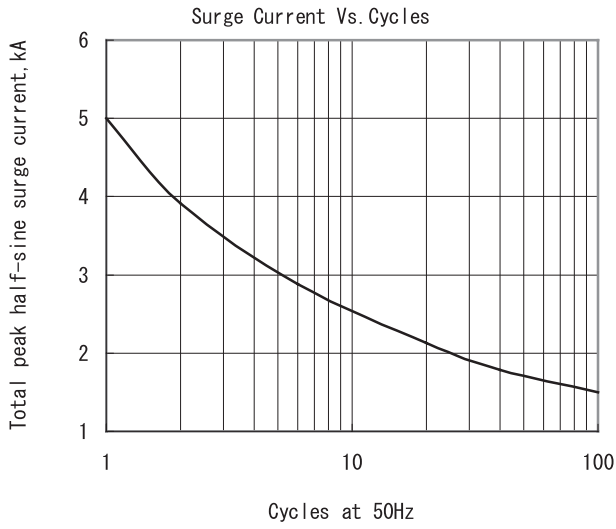

Fig. 8

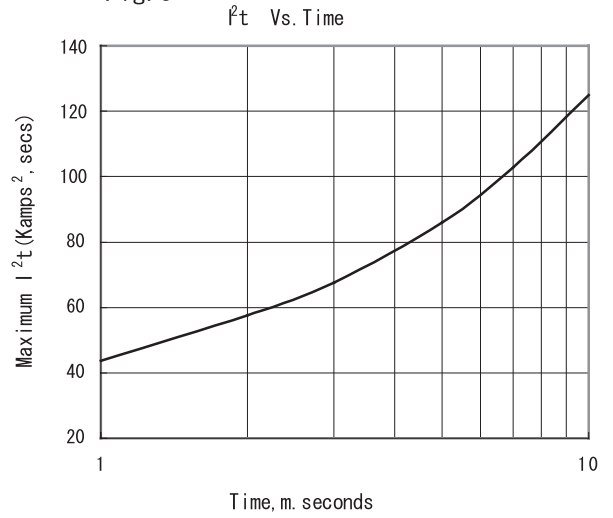

Fig. 9

Gate characteristic at 25°C junction temperature

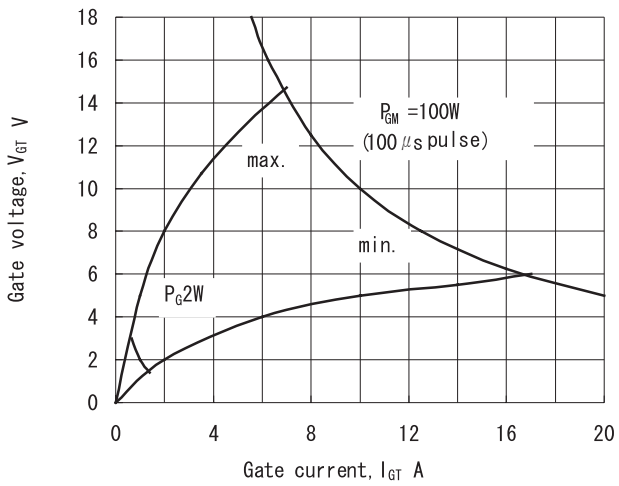

Fig. 10

Gate Trigger Zone at varies temperature

