



# 4N65-S

**Power MOSFET**

## 4A, 650V N-CHANNEL POWER MOSFET

■ DESCRIPTION

The UTC **4N65-S** is a high voltage power MOSFET designed to have better characteristics, such as fast switching time, low gate charge, low on-state resistance and have a high rugged avalanche characteristic. This power MOSFET is usually used in high speed switching applications including power supplies, PWM motor controls, high efficient DC to DC converters and bridge circuits.

■ FEATURES

- \*  $R_{DS(ON)} < 2.9\Omega @ V_{GS} = 10V, I_D = 2A$
- \* Fast Switching Capability
- \* Avalanche Energy Specified
- \* Improved dv/dt Capability, High Ruggedness

■ SYMBOL

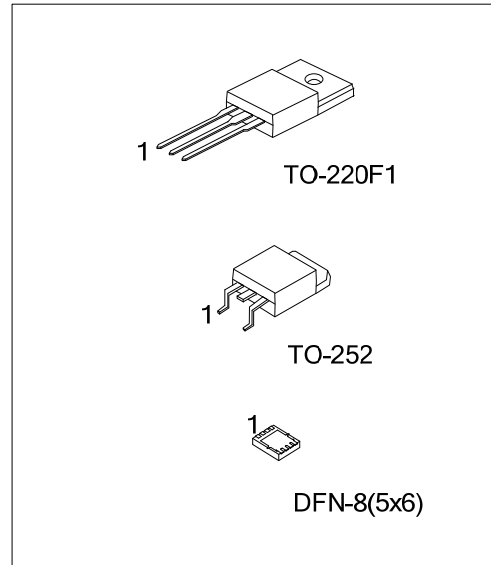
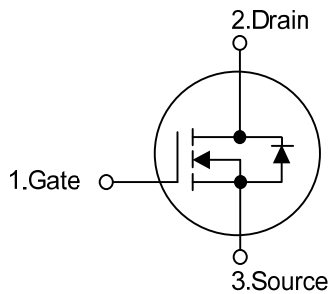

■ ORDERING INFORMATION

Ordering Number		Package	Pin Assignment								Packing
Lead Free	Halogen Free		1	2	3	4	5	6	7	8	
4N65L-TF1-T	4N65G-TF1-T	TO-220F1	G	D	S	-	-	-	-	-	Tube
4N65L-TN3-T	4N65G-TN3-T	TO-252	G	D	S	-	-	-	-	-	Tape Reel
-	4N65G-K08-5060-R	DFN-8(5x6)	S	S	S	G	D	D	D	D	Tape Reel

Note: Pin Assignment: G: Gate D: Drain S: Source

<p>4N65L-TF1-T</p> <p>(1)Packing Type (2)Package Type (3)Green Package</p>	<p>(1) T: Tube, R: Tape Reel (2) TF1: TO-220F1, TN3: TO-252, K08-5060: DFN-8(5x6) (3) L: Lead Free, G: Halogen Free and Lead Free</p>
--	---

■ MARKING

TO-220F1 / TO-252	DFN-8(5x6)
<p>UTC 4N65</p> <p>L: Lead Free G: Halogen Free Data Code</p> <p>Lot Code</p>	<p>UTC 4N65</p> <p>Date Code</p> <p>Lot Code</p>

■ ABSOLUTE MAXIMUM RATINGS ( $T_C = 25^\circ\text{C}$ , unless otherwise specified)

PARAMETER		SYMBOL	RATINGS	UNIT
Drain-Source Voltage		$V_{DSS}$	650	V
Gate-Source Voltage		$V_{GSS}$	$\pm 30$	V
Drain Current	Continuous	$I_D$	4.0	A
	Pulsed (Note2)	$I_{DM}$	16	A
Avalanche Energy	Single Pulsed (Note3)	$E_{AS}$	150	mJ
Peak Diode Recovery dv/dt (Note4)		dv/dt	4.5	V/ns
Power Dissipation	TO-220F1	$P_D$	36	W
	TO-252		50	W
	DFN-8(5×6)		30	W
Junction Temperature		$T_J$	+150	$^\circ\text{C}$
Operating Temperature		$T_{OPR}$	-55 ~ +150	$^\circ\text{C}$
Storage Temperature		$T_{STG}$	-55 ~ +150	$^\circ\text{C}$

Note: 1. Absolute maximum ratings are those values beyond which the device could be permanently damaged.

Absolute maximum ratings are stress ratings only and functional device operation is not implied.

2. Repetitive Rating: Pulse width limited by maximum junction temperature.

3.  $L = 18.75\text{mH}$ ,  $I_{AS} = 4\text{A}$ ,  $V_{DD} = 50\text{V}$ ,  $R_G = 25\ \Omega$ , Starting  $T_J = 25^\circ\text{C}$

4.  $I_{SD} \leq 4\text{A}$ ,  $di/dt \leq 200\text{A}/\mu\text{s}$ ,  $V_{DD} \leq BV_{DSS}$ , Starting  $T_J = 25^\circ\text{C}$

■ THERMAL DATA

PARAMETER	PACKAGE	SYMBOL	RATINGS	UNIT
Junction to Ambient	TO-220F1	$\theta_{JA}$	62.5	$^\circ\text{C}/\text{W}$
	TO-252		110	$^\circ\text{C}/\text{W}$
	DFN-8(5×6)		75 (Note)	$^\circ\text{C}/\text{W}$
Junction to Case	TO-220F1	$\theta_{JC}$	3.47	$^\circ\text{C}/\text{W}$
	TO-252		2.5	$^\circ\text{C}/\text{W}$
	DFN-8(5×6)		4.17 (Note)	$^\circ\text{C}/\text{W}$

Note: Note: The data tested by surface mounted on a 1 inch<sup>2</sup> FR-4 board with 2OZ copper.

■ ELECTRICAL CHARACTERISTICS (T<sub>C</sub>=25°C, unless otherwise specified)

PARAMETER	SYMBOL	TEST CONDITIONS	MIN	TYP	MAX	UNIT
<b>OFF CHARACTERISTICS</b>						
Drain-Source Breakdown Voltage	BV <sub>DSS</sub>	V <sub>GS</sub> = 0 V, I <sub>D</sub> = 250μA	650			V
Drain-Source Leakage Current	I <sub>DSS</sub>	V <sub>DS</sub> = 650 V, V <sub>GS</sub> = 0 V			10	μA
Gate-Source Leakage Current	Forward	I <sub>GSS</sub>			100	nA
	Reverse				-100	nA
Breakdown Voltage Temperature Coefficient	ΔBV <sub>DSS</sub> /ΔT <sub>J</sub>	I <sub>D</sub> =250μA, Referenced to 25°C		0.6		V/°C
<b>ON CHARACTERISTICS</b>						
Gate Threshold Voltage	V <sub>GS(TH)</sub>	V <sub>DS</sub> = V <sub>GS</sub> , I <sub>D</sub> = 250μA	2.0		4.0	V
Static Drain-Source On-State Resistance	R <sub>DS(ON)</sub>	V <sub>GS</sub> = 10 V, I <sub>D</sub> = 2A			2.9	Ω
<b>DYNAMIC CHARACTERISTICS</b>						
Input Capacitance	C <sub>ISS</sub>	V <sub>DS</sub> = 25 V, V <sub>GS</sub> = 0V, f = 1MHz		420	550	pF
Output Capacitance	C <sub>OSS</sub>			40	60	pF
Reverse Transfer Capacitance	C <sub>RSS</sub>			4	8	pF
<b>SWITCHING CHARACTERISTICS<sup>10</sup></b>						
Turn-On Delay Time	t <sub>D(ON)</sub>	V <sub>DS</sub> = 30 V, I <sub>D</sub> = 0.5 A, R <sub>G</sub> = 25Ω (Note 1, 2)		60		ns
Turn-On Rise Time	t <sub>R</sub>			25		ns
Turn-Off Delay Time	t <sub>D(OFF)</sub>			125		ns
Turn-Off Fall Time	t <sub>F</sub>			30		ns
Total Gate Charge	Q <sub>G</sub>	V <sub>DS</sub> = 50 V, I <sub>D</sub> = 1.3 A, V <sub>GS</sub> = 10V (Note 1, 2)		15	20	nC
Gate-Source Charge	Q <sub>GS</sub>			5		nC
Gate-Drain Charge	Q <sub>GD</sub>			2		nC
<b>SOURCE- DRAIN DIODE RATINGS AND CHARACTERISTICS</b>						
Drain-Source Diode Forward Voltage	V <sub>SD</sub>	V <sub>GS</sub> = 0 V, I <sub>S</sub> = 4A			1.4	V
Maximum Continuous Drain-Source Diode Forward Current	I <sub>S</sub>				4	A
Maximum Pulsed Drain-Source Diode Forward Current	I <sub>SM</sub>				16	A

Note: 1. Pulse Test: Pulse width ≤ 300μs, Duty cycle ≤ 2%.  
 2. Essentially independent of operating temperature.

■ TEST CIRCUITS AND WAVEFORMS

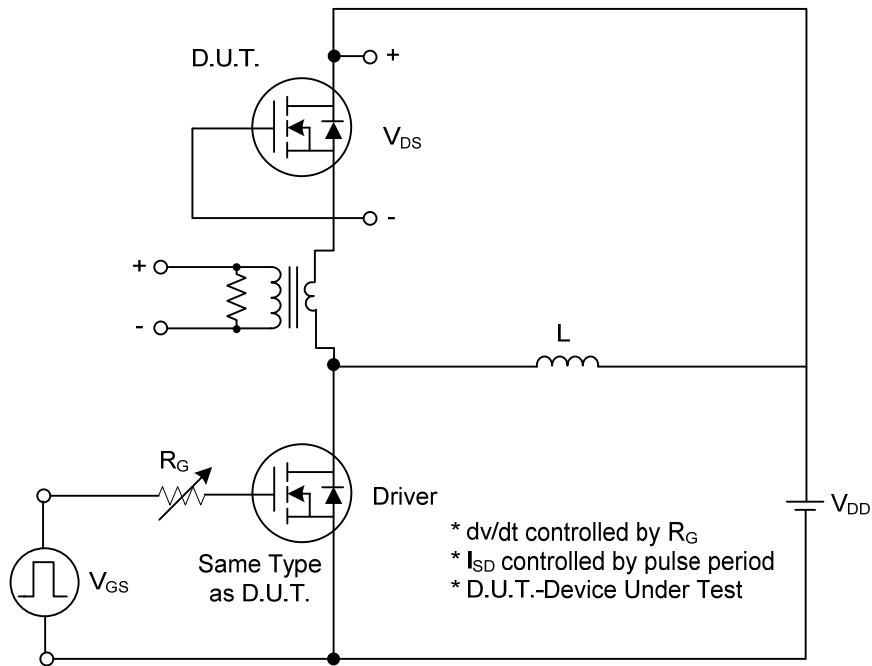

Peak Diode Recovery  $dv/dt$  Test Circuit

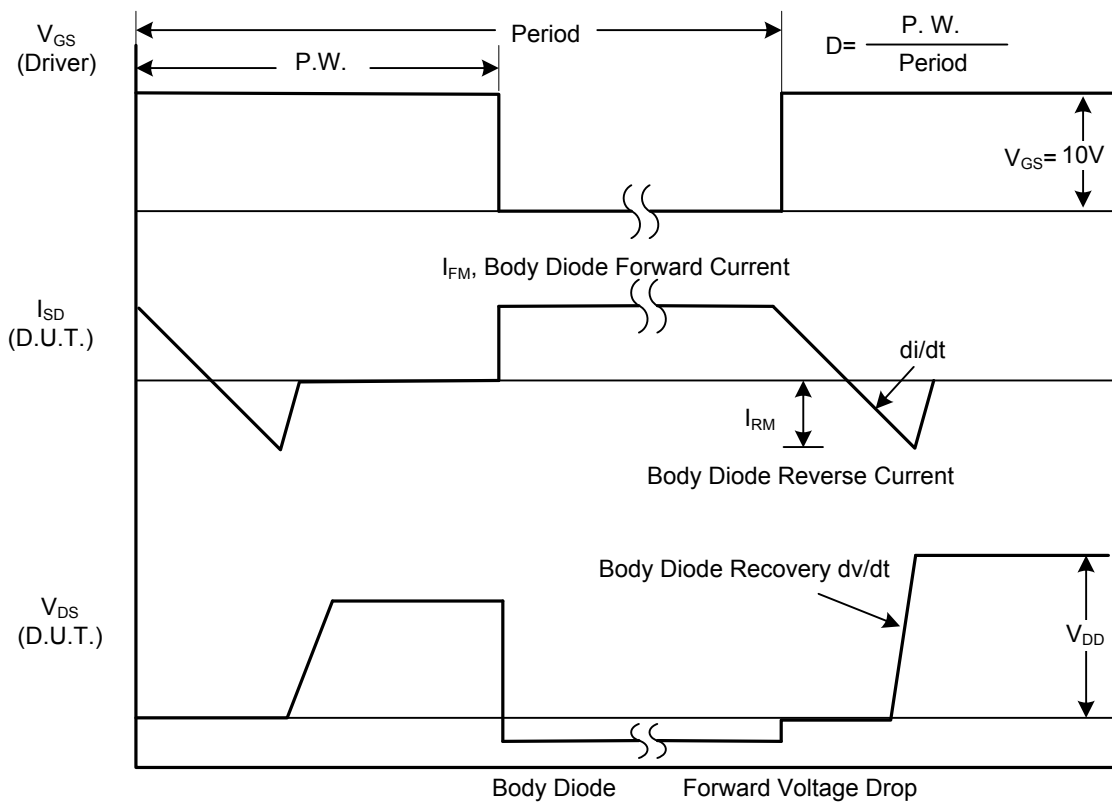

Peak Diode Recovery  $dv/dt$  Waveforms

## TEST CIRCUITS AND WAVEFORMS (Cont.)

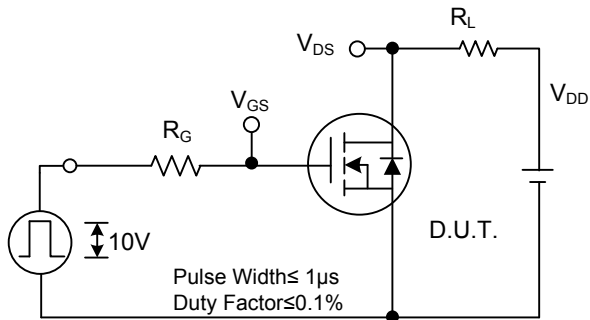

**Switching Test Circuit**

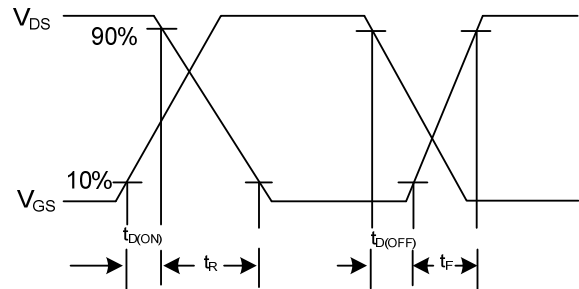

**Switching Waveforms**

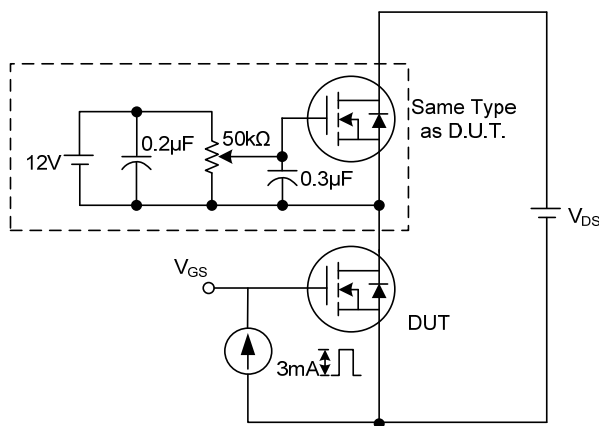

**Gate Charge Test Circuit**

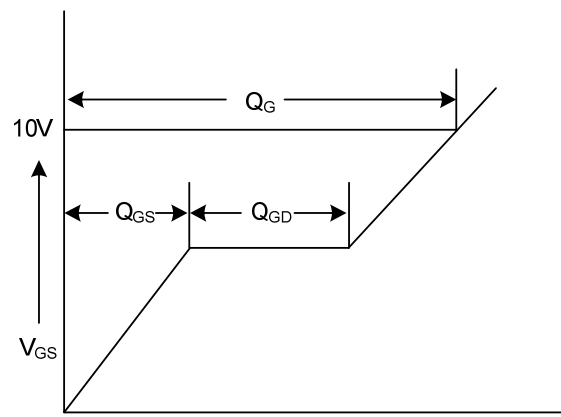

**Gate Charge Waveform**

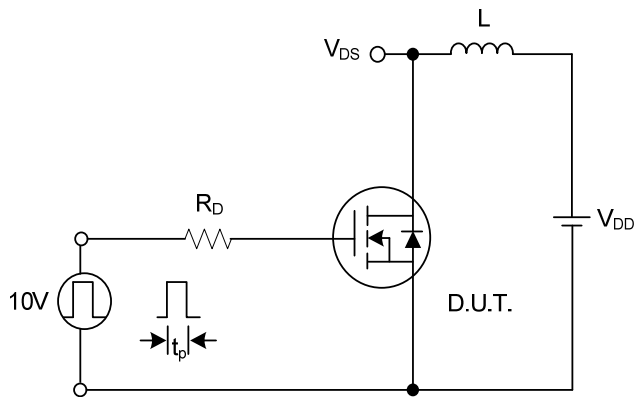

**Unclamped Inductive Switching Test Circuit**

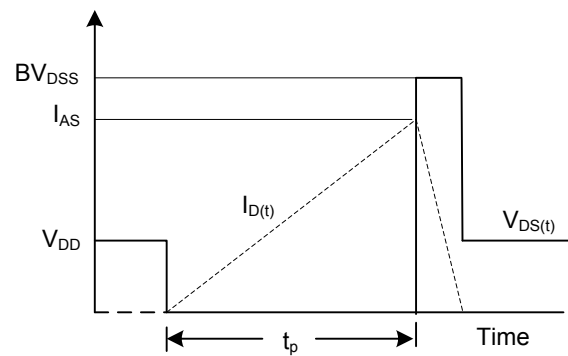

**Unclamped Inductive Switching Waveforms**

UTC assumes no responsibility for equipment failures that result from using products at values that exceed, even momentarily, rated values (such as maximum ratings, operating condition ranges, or other parameters) listed in products specifications of any and all UTC products described or contained herein. UTC products are not designed for use in life support appliances, devices or systems where malfunction of these products can be reasonably expected to result in personal injury. Reproduction in whole or in part is prohibited without the prior written consent of the copyright owner. The information presented in this document does not form part of any quotation or contract, is believed to be accurate and reliable and may be changed without notice.