

Sensitive gate SCRs, 4A

Main Features

Symbol	Value	Unit
$I_{T(RMS)}$	4	A
V_{DRM}/V_{RRM}	600 to 800	V
I_{GT}	10 to 200	μA

DESCRIPTION

Thanks to highly sensitive triggering levels, the 4PT series is suitable for all applications where the available gate current is limited, such as motor control for hand tools, kitchen aids, capacitive discharge ignitions, overvoltage crowbar protection for low power supplies among others.

Available in through-hole or surface-mount packages, they provide an optimized performance in a limited space area.

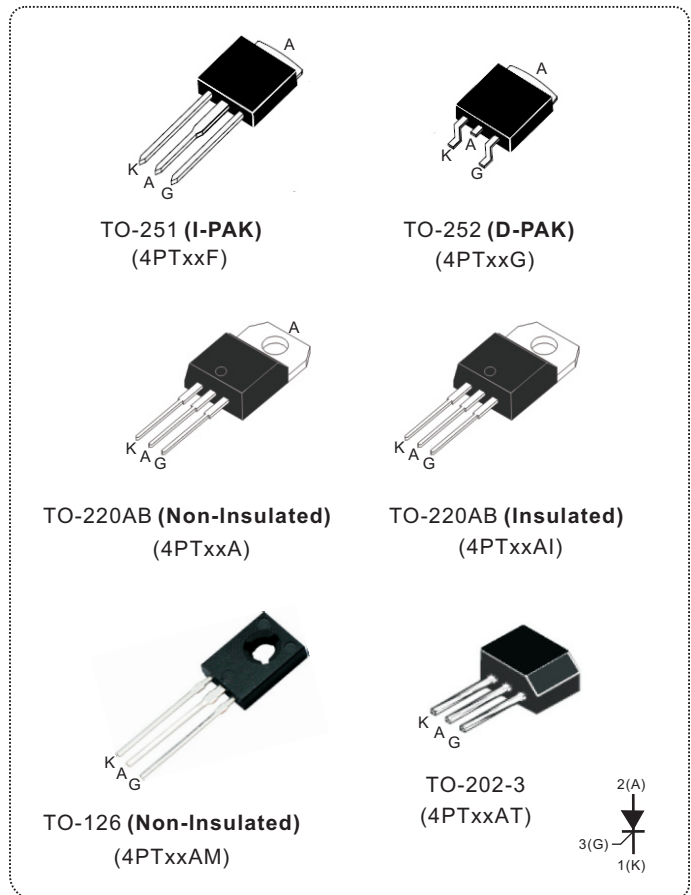

ABSOLUTE MAXIMUM RATINGS

PARAMETER	SYMBOL	TEST CONDITIONS		VALUE	UNIT
RMS on-state current full sine wave (180° conduction angle)	$I_{T(RMS)}$	TO-251/TO-252/TO-220AB	$T_c=115^\circ C$	4	A
		TO-220AB insulated	$T_c=110^\circ C$		
		TO-126	$T_c=95^\circ C$		
		TO-202-3	$T_c=60^\circ C$		
Average on-state current (180° conduction angle)	$I_{T(AV)}$	TO-251/TO-252/TO-220AB	$T_c=115^\circ C$	2.5	A
		TO-220AB insulated	$T_c=110^\circ C$		
		TO-126	$T_c=95^\circ C$		
		TO-202-3	$T_c=60^\circ C$		
Non repetitive surge peak on-state current (full cycle, T_j initial = 25°C)	I_{TSM}	F = 50 Hz	t = 20 ms	30	A
		F = 60 Hz	t = 16.7 ms	33	
I^2t Value for fusing	I^2t	$t_p = 10$ ms		4.5	A^2s
Critical rate of rise of on-state current $I_G = 2xI_{GT}$, $t_r \leq 100ns$	di/dt	F = 60 Hz	$T_j = 125^\circ C$	50	A/ μs
Peak gate current	I_{GM}	$T_p = 20 \mu s$	$T_j = 125^\circ C$	1.2	A
Average gate power dissipation	$P_{G(AV)}$	$T_j = 125^\circ C$		0.2	W
Repetitive peak off-state voltage	V_{DRM}	$T_j = 125^\circ C$		600 and 800	V
Repetitive peak reverse voltage	V_{RRM}				
Storage temperature range	T_{stg}			- 40 to + 150	°C
Operating junction temperature range	T_j			- 40 to + 125	

ELECTRICAL SPECIFICATIONS (T_J = 25 °C unless otherwise specified)

SYMBOL	TEST CONDITIONS		4PTxxxx	Unit	
I _{GT}	V _D = 12V, R _L = 30Ω	Min.	10	μA	
		Max.	200		
V _{GT}		Max.	0.8	V	
V _{GD}	V _D = V _{DRM} , R _L = 3.3KΩ, R _{GK} = 220Ω, T _J = 125°C	Min.	0.1	V	
I _H	I _T = 50mA, R _{GK} = 1KΩ	Max.	5	mA	
I _L	I _G = 1mA, R _{GK} = 1KΩ	Max.	6	mA	
dV/dt	V _D = 67% V _{DRM} , R _{GK} = 1KΩ, T _J = 125°C	Min.	10	V/μs	
V _{TM}	I _T = 8A, t _p = 380 μs	T _J = 25°C	Max.	1.6	V
I _{DRM}	V _D = V _{DRM} , V _R = V _{RRM}	T _J = 25°C	Max.	5	μA
I _{RRM}	R _{GK} = 1K	T _J = 125°C	Max.	1	mA

THERMAL RESISTANCE

SYMBOL	Parameter		VALUE	UNIT
R _{th(j-c)}	Junction to case (DC)	IPAK/DPAK/TO-220AB/TO-126	2.8	°C/W
R _{th(j-a)}	Junction to ambient	S = 0.5 cm ² TO-252(D-PAK)	70	
		TO-220AB	60	
		TO-251(I-PAK)/TO-126	100	
R _{th(j-l)}	Junction to lead (DC)	TO-202-3	15	

PRODUCT SELECTOR

PART NUMBER	VOLTAGE (xx)		SENSITIVITY	PACKAGE
	600 V	800 V		
4PTxxA-S/4PTxxAI-S	V	V	70~200 μA	TO-220AB
4PTxxA-03/4PTxxAI-03	V	V	10~30 μA	TO-220AB
4PTxxA-05/4PTxxAI-05	V	V	20~30 μA	TO-220AB
4PTxxA-06/4PTxxAI-06	V	V	30~60 μA	TO-220AB
4PTxxA-08/4PTxxAI-08	V	V	50~80 μA	TO-220AB
4PTxxF-S	V	V	70~200 μA	I-PAK
4PTxxF-03	V	V	10~30 μA	I-PAK
4PTxxF-05	V	V	20~30 μA	I-PAK
4PTxxF-06	V	V	30~60 μA	I-PAK
4PTxxF-08	V	V	50~80 μA	I-PAK
4PTxxG-S	V	V	70~200 μA	D-PAK
4PTxxG-03	V	V	10~30 μA	D-PAK
4PTxxG-05	V	V	20~30 μA	D-PAK
4PTxxG-06	V	V	30~60 μA	D-PAK
4PTxxG-08	V	V	50~80 μA	D-PAK
4PTxxAM-S	V	V	70~200 μA	TO-126
4PTxxAM-03	V	V	10~30 μA	TO-126
4PTxxAM-05	V	V	20~30 μA	TO-126
4PTxxAM-06	V	V	30~60 μA	TO-126
4PTxxAM-08	V	V	50~80 μA	TO-126
4PTxxAT-03	V	V	10~30 μA	TO-202-3
4PTxxAT-06	V	V	30~60 μA	TO-202-3
4PTxxAT-08	V	V	50~80 μA	TO-202-3

ORDERING INFORMATION					
ORDERING TYPE	MARKING	PACKAGE	WEIGHT	BASE Q'TY	DELIVERY MODE
4PTxxA-yy	4PTxxA-yy	TO-220AB	2.0g	50	Tube
4PTxxAI-yy	4PTxxAI-yy	TO-220AB (insulated)	2.3g	50	Tube
4PTxxF-yy	4PTxxF-yy	TO-251(I-PAK)	0.40g	80	Tube
4PTxxG-yy	4PTxxG-yy	TO-252(D-PAK)	0.38g	80	Tube
4PTxxAM-yy	4PTxxAM-yy	TO-126	0.75g	500	Bag
4PTxxAT-yy	4PTxxAT-yy	TO-202-3	g	500	Bag

Note: xx = voltage, yy = sensitivity

ORDERING INFORMATION SCHEME	
<p>4 PT 06 AI - S</p>	<p>Current 4 = 4A, $I_{T(RMS)}$</p> <p>SCR series</p> <p>Voltage Code 06 = 600V 08 = 800V</p> <p>Package type A = TO-220AB (non-insulated) AI = TO-220AB (insulated) F = TO-251 (I-PAK) G = TO-252 (D-PAK) AM = TO-126 AT = TO-202-3</p> <p>IGT Sensitivity 03 = 10~30 μA 05 = 20~50 μA 06 = 30~60 μA 08 = 50~80 μA S = 70~200 μA</p>

Fig.1 Maximum average power dissipation versus on-state current

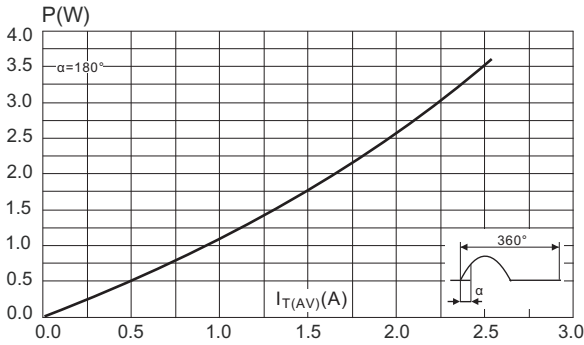

Fig.2 Average and DC on-state current versus case temperature

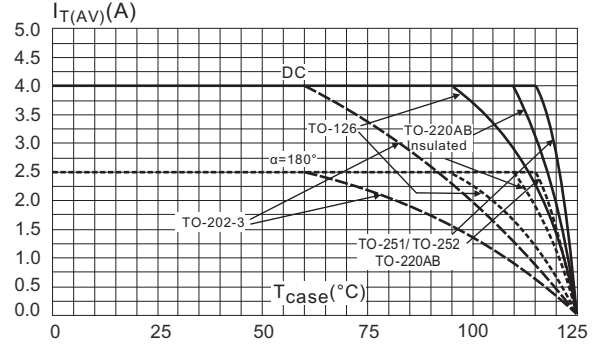

Fig.3 Average and DC on-state current versus ambient temperature (DPAK)

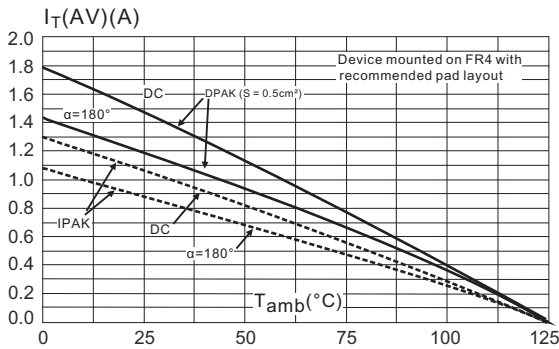

Fig.4 Relative variation of thermal impedance junction to ambient versus pulse duration (DPAK)

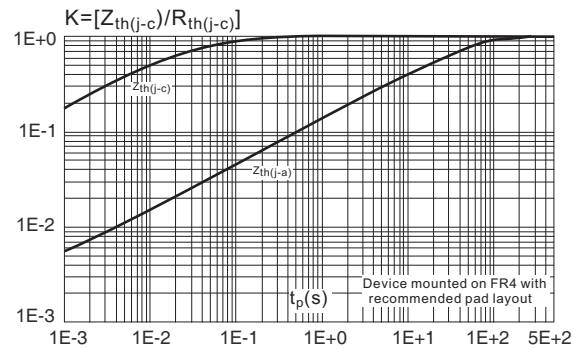

Fig.5 Relative variation of gate trigger current and holding current versus junction temperature

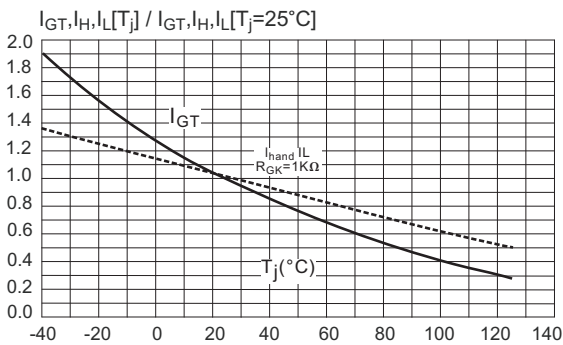

Fig.6 Relative variation of holding current versus gate-cathode resistance (typical values)

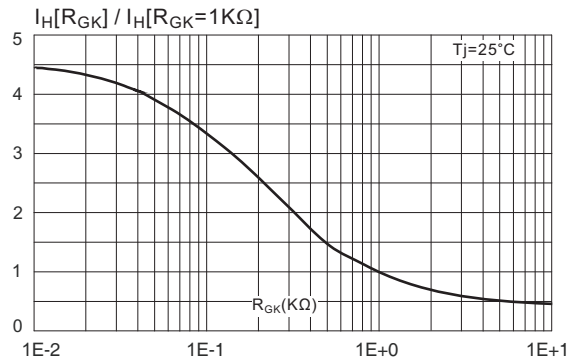

Fig.7 Relative variation of dV/dt immunity versus gate-cathode resistance (typical values)

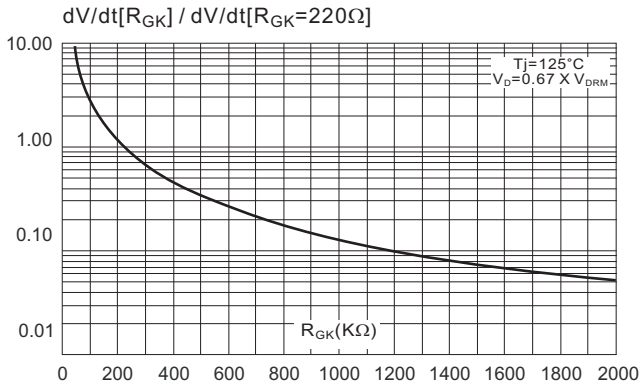

Fig.8 Relative variation of dV/dt immunity versus gate-cathode capacitance (typical values)

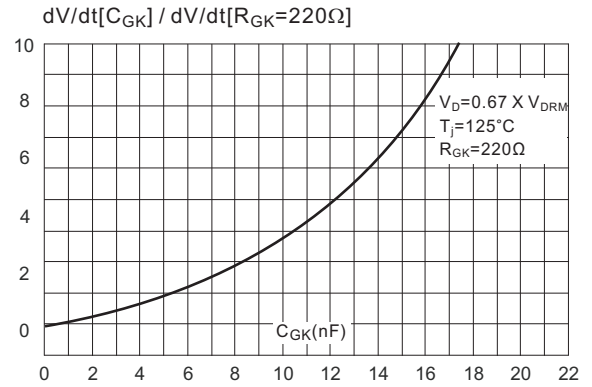

Fig.9 Surge peak on-state current versus number of cycles

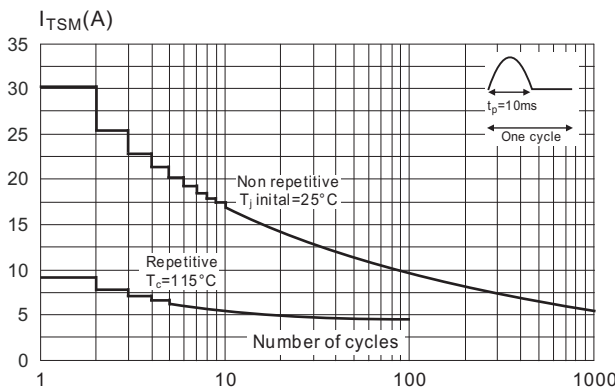

Fig.10 Non-repetitive surge peak on-state current, and corresponding values of I²t

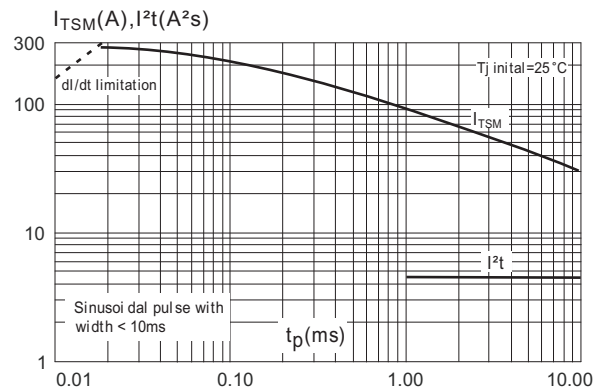

Fig.11 On-state characteristics (maximum values)

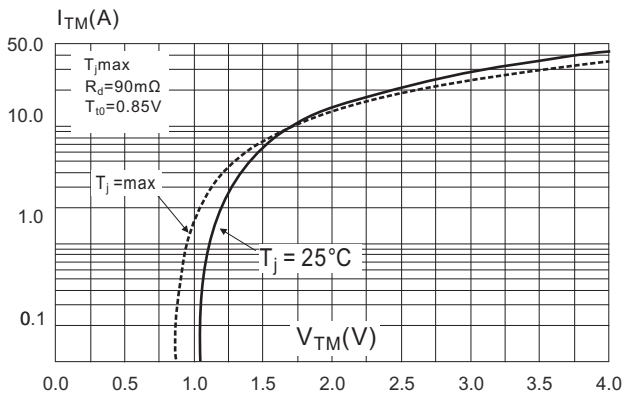
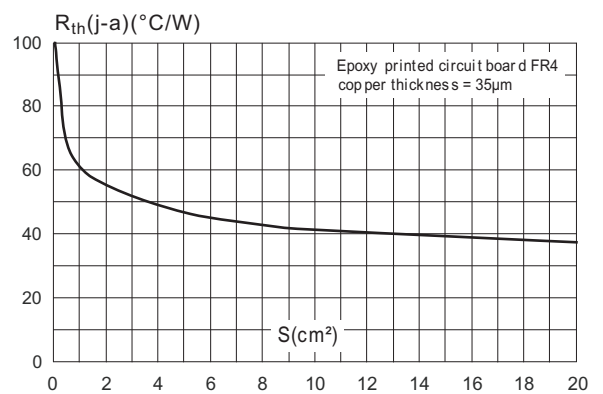
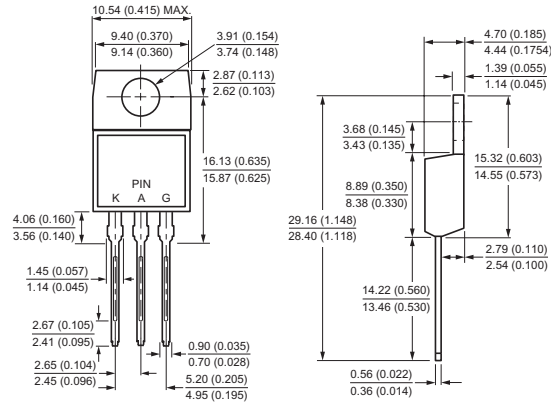

Fig.12 Thermal resistance junction to ambient versus copper surface under tab (DPAK)



Case Style

TO-220AB



**TO-251
(I-PAK)**

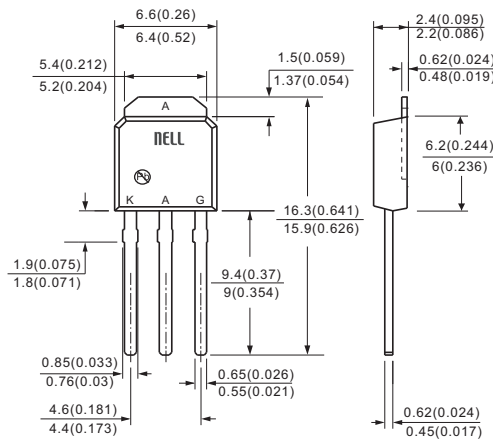

**TO-252
(D-PAK)**

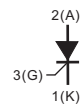
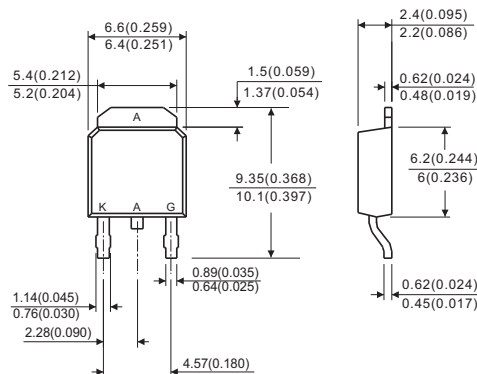

All dimensions in millimeters(inches)

Case Style

TO-202-3

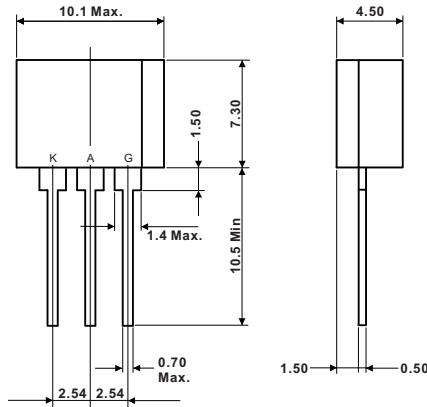

TO-126

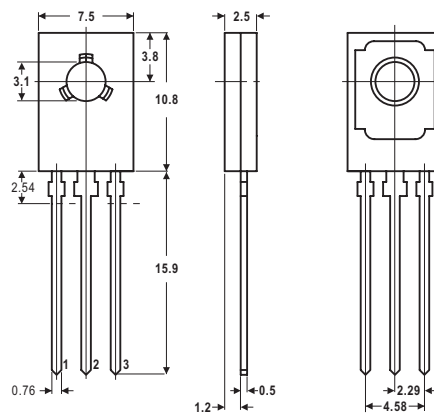

All dimensions in millimeters(inches)

