



54170/DM74170 4 x 4 Register File with Open-Collector Outputs

General Description

The '170 contains 16 high speed, low power, transparent D-type latches arranged as four words of four bits each, to function as a 4 x 4 register file. Separate read and write inputs, both address and enable, allow simultaneous read and write operation. Open-collector outputs make it possible to connect up to 128 outputs in a wired-AND configuration to increase the word capacity up to 512 words. Any number of these devices can be operated in parallel to generate an n-bit length.

Connection Diagram

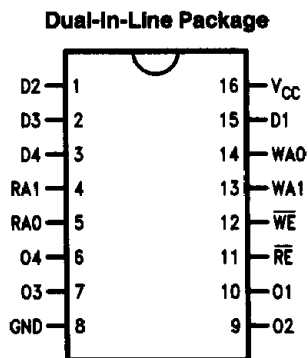

TL/F/9783-1

Order Number 54170DMQB, 54170FMQB or DM74170N
See NS Package Number J16A, N16E and W16A

Logic Symbol

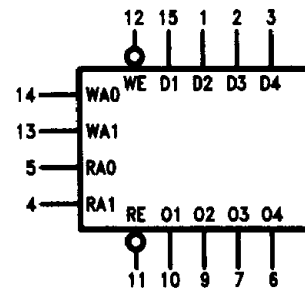

V_{CC} = Pin 16
GND = Pin 8

TL/F/9783-2

Pin Names	Description
D1-D4	Data Inputs
WA0, WA1	Write Address Inputs
WE	Write Enable Input (Active LOW)
RA0-RA1	Read Address Inputs
RE	Read Enable Input (Active LOW)
O1-O4	Data Outputs

Absolute Maximum Ratings

If Military/Aerospace specified devices are required, please contact the National Semiconductor Sales Office/Distributors for availability and specifications.

Supply Voltage	7V
Input Voltage	5.5V
Operating Free Air Temperature Range	
54	-55°C to +125°C
DM74	0°C to +70°C
Storage Temperature Range	-65°C to +150°C

Note: The "Absolute Maximum Ratings" are those values beyond which the safety of the device cannot be guaranteed. The device should not be operated at these limits. The parametric values defined in the "Electrical Characteristics" table are not guaranteed at the absolute maximum ratings. The "Recommended Operating Conditions" table will define the conditions for actual device operation.

Recommended Operating Conditions

Symbol	Parameter	54170			DM74170			Units
		Min	Nom	Max	Min	Nom	Max	
V _{CC}	Supply Voltage	4.5	5	5.5	4.75	5	5.25	V
V _{IH}	High Level Input Voltage	2			2			V
V _{IL}	Low Level Input Voltage			0.8			0.8	V
V _{OH}	High Level Output Voltage			5.5				V
I _{OL}	Low Level Output Current			16			16	mA
T _A	Free Air Operating Temperature	-55		125	0		70	°C
t _s	Setup Time HIGH or LOW D _n to Rising \overline{WE}	10			10			ns
t _h	Hold Time HIGH or LOW D _n to Rising \overline{WE}	15			15			ns
t _s	Setup Time HIGH or LOW WA _n to Falling \overline{WE}	15			15			ns
t _h	Hold Time HIGH or LOW WA _n to Rising \overline{WE}	5.0			5.0			ns
t _w (L)	\overline{WE} or \overline{RE} Pulse Width LOW	25			25			ns

Electrical Characteristics

Over recommended operating free air temperature range (unless otherwise noted)

Symbol	Parameter	Conditions	Min	Typ (Note 1)	Max	Units
V _I	Input Clamp Voltage	V _{CC} = Min, I _I = -12 mA			-1.5	V
I _{OH}	High Level Output Current	V _{CC} = Min, V _{OH} = Max V _{IL} = Max			30	μA
V _{OL}	Low Level Output Voltage	V _{CC} = Min, I _{OL} = Max V _{IH} = Min		0.2	0.4	V
I _I	Input Current @ Max Input Voltage	V _{CC} = Max, V _I = 5.5V			1	mA
I _{IH}	High Level Input Current	V _{CC} = Max, V _I = 2.4V			40	μA
I _{IL}	Low Level Input Current	V _{CC} = Max, V _I = 0.4V			-1.6	mA
I _{CC}	Supply Current	V _{CC} = Max, RA _n = 0V D _n , \overline{WE} , \overline{RE} = 4.5V				
			54		140	mA
			DM74		150	mA

Note 1: All typicals are at V_{CC} = 5V, T_A = 25°C.

Switching Characteristics

$V_{CC} = +5.0V$, $T_A = +25^\circ C$ (See Section 2 for waveforms and load configurations)

Symbol	Parameter	54/DM74		Units
		$C_L = 15 \text{ pF}$ $R_L = 400\Omega$		
		Min	Max	
t_{PLH} t_{PHL}	Propagation Delay* RA ₀ or RA ₁ to O _n		35 40	ns
t_{PLH} t_{PHL}	Propagation Delay \overline{RE} to O _n		15 30	ns
t_{PLH} t_{PHL}	Propagation Delay \overline{WE} to O _n		40 45	ns
t_{PLH} t_{PHL}	Propagation Delay D _n to O _n		30 45	ns

*Measured at least 25 ns after entry of new data at selected location.

Timing Waveforms

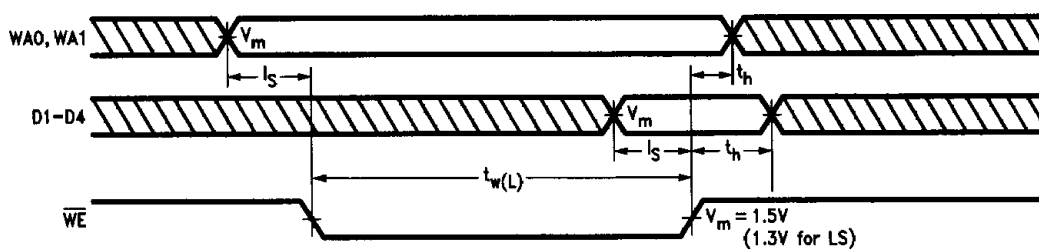

TL/F/9783-4

Logic Diagram

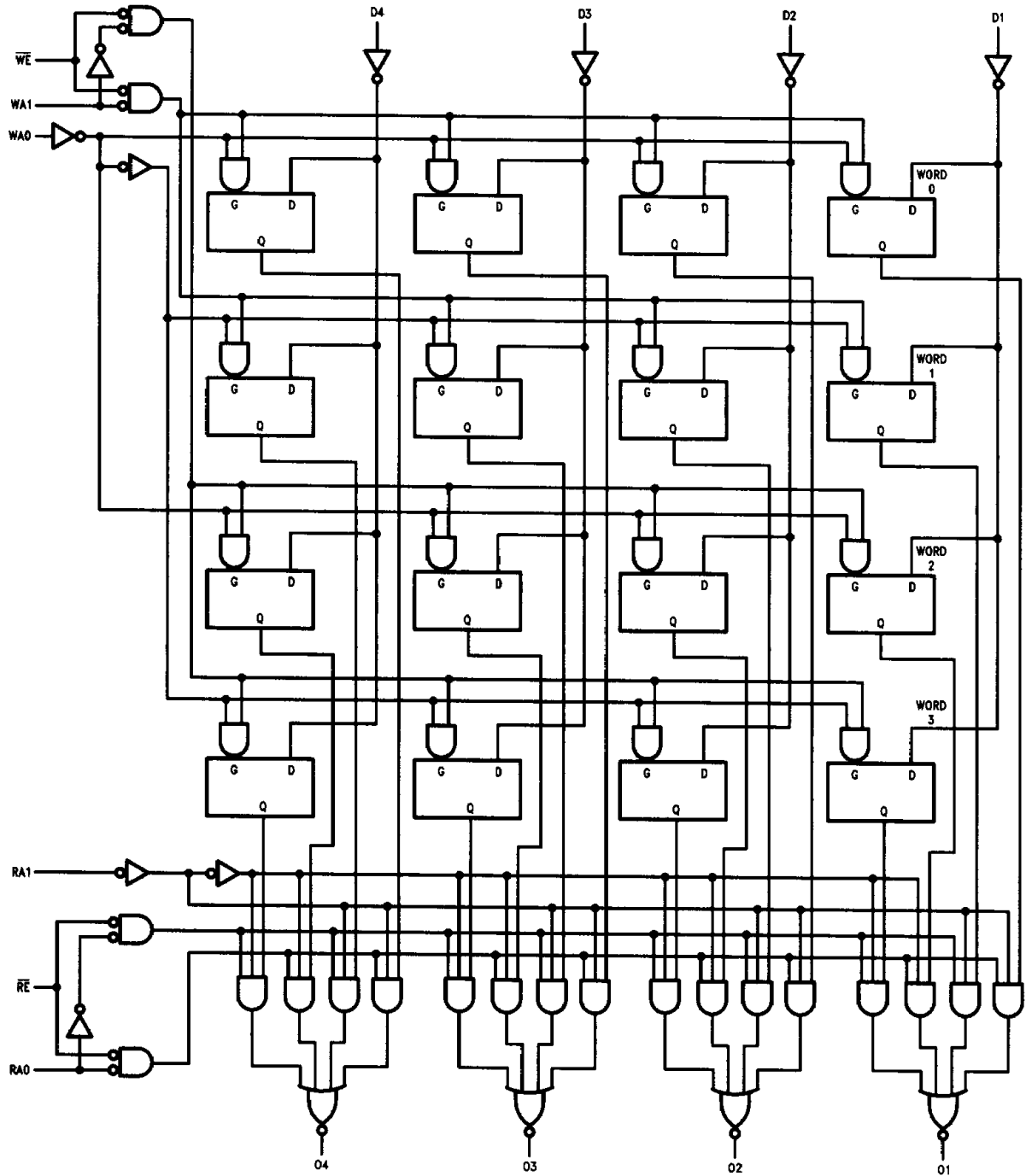

TL/F/9783-3

Write Function Table

Write Inputs			D Inputs To
WE	WA ₁	WA ₀	
L	L	L	Word 0
L	L	H	Word 1
L	H	L	Word 2
L	H	H	Word 3
H	X	X	None (Hold)

Read Function Table

Read Inputs			Outputs From
RE	RA ₁	RA ₀	
L	L	L	Word 0
L	L	H	Word 1
L	H	L	Word 2
L	H	H	Word 3
H	X	X	None (HIGH Z)

H = HIGH Voltage Level L = LOW Voltage Level X = Immaterial