

# 54AC05

## Hex Inverter with Open Drain Outputs

### General Description

The 'AC05 contains six inverters.

### Features

- Outputs sink 24 mA
- Open drain for wired NOR function
- Standard Microcircuit Drawing (SMD) 5962-9059001

### Logic Symbol

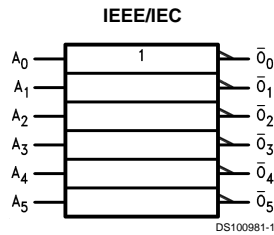

### Connection Diagrams

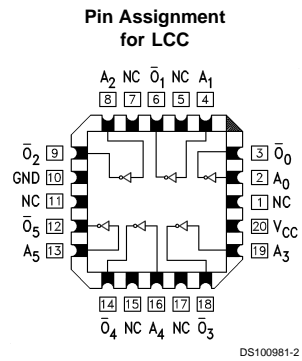
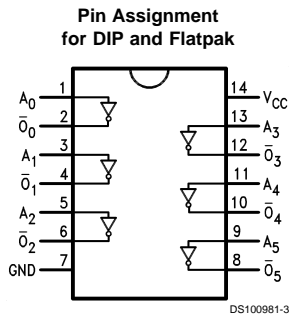

Pin Names	Description
$A_n$	Inputs
$\bar{O}_n$	Outputs

FACT™ is a trademark of Fairchild Semiconductor Corporation.

### Absolute Maximum Ratings (Note 1)

If Military/Aerospace specified devices are required, please contact the National Semiconductor Sales Office/Distributors for availability and specifications.

Supply Voltage ( $V_{CC}$ )	-0.5V to +7.0V
DC Input Diode Current ( $I_{IK}$ )	
$V_I = -0.5V$	-20 mA
$V_I = V_{CC} + 0.5V$	+20 mA
DC Input Voltage ( $V_I$ )	-0.5V to $V_{CC} + 0.5V$
DC Output Diode Current ( $I_{OK}$ )	
$V_O = -0.5V$	-20 mA
$V_O = V_{CC} + 0.5V$	+20 mA
DC Output Voltage ( $V_O$ )	-0.5V to to $V_{CC} + 0.5V$
DC Output Source	
or Sink Current ( $I_O$ )	±50 mA
DC $V_{CC}$ or Ground Current	
per Output Pin ( $I_{CC}$ or $I_{GND}$ )	±50 mA

Storage Temperature ( $T_{STG}$ )	-65°C to +150°C
Junction Temperature ( $T_J$ )	
CDIP	175°C

### Recommended Operating Conditions

Supply Voltage ( $V_{CC}$ )	'AC	2.0V to 6.0V
Input Voltage ( $V_I$ )		0V to $V_{CC}$
Output Voltage ( $V_O$ )		0V to $V_{CC}$
Operating Temperature ( $T_A$ )	54AC	-55°C to +125°C
Minimum Input Edge Rate ( $\Delta V/\Delta t$ )		
$V_{IN}$ from 30% to 70% of $V_{CC}$		
$V_{CC}$ @ 3.3V, 4.5V, 5.5V		125 mV/ns

**Note 1:** Absolute maximum ratings are those values beyond which damage to the device may occur. The databook specifications should be met, without exception, to ensure that the system design is reliable over its power supply, temperature, and output/input loading variables. National does not recommend operation of FACT® circuits outside databook specifications.

### DC Characteristics for 'AC Family Devices

Symbol	Parameter	$V_{CC}$ (V)	54AC	Units	Conditions
			$T_A = -55^\circ\text{C to } +125^\circ\text{C}$		
			Guaranteed Limits		
$V_{IH}$	Minimum High Level Input Voltage	3.0	2.1	V	$V_{OUT} = 0.1V$ or $V_{CC} - 0.1V$
		4.5	3.15		
		5.5	3.85		
$V_{IL}$	Maximum Low Level Input Voltage	3.0	0.9	V	$V_{OUT} = 0.1V$ or $V_{CC} - 0.1V$
		4.5	1.35		
		5.5	1.65		
$V_{OL}$	Maximum Low Level Output Voltage	3.0	0.1	V	$I_{OUT} = 50 \mu A$
		4.5	0.1		
		5.5	0.1		
		3.0	0.5	V	(Note 2) $V_{IN} = V_{IL}$ or $V_{IH}$ 12 mA $I_{OL}$ 24 mA 24 mA
		4.5	0.5		
	5.5	0.5			
$I_{IN}$	Maximum Input Leakage Current	5.5	±1.0	μA	$V_I = V_{CC}, GND$
$I_{OHC}$	Output Leakage Current High	5.5	-10.0	μA	$V_{IN} = V_{CC}$
$I_{OLD}$	Minimum Dynamic Output Current	5.5	50.0	mA	$V_{OLD} = 1.65V$ Max (Note 3)
$I_{CC}$	Maximum Quiescent Supply Current	5.5	80.0	μA	$V_{IN} = V_{CC}$ or GND

**Note 2:** All outputs loaded; thresholds on input associated with output under test.

**Note 3:** Maximum test duration 2.0 ms, one output loaded at a time.

## AC Electrical Characteristics

Symbol	Parameter	V <sub>CC</sub> (V) (Note 4)	54AC		Units	Fig. No.
			T <sub>A</sub> = -55°C to +125°C C <sub>L</sub> = 50 pF			
			Min	Max		
t <sub>PLH</sub>	Propagation Delay	3.3	1.0	15.5	ns	
		5.0	1.0	15.5		
t <sub>PHL</sub>	Propagation Delay	3.3	1.0	8.0	ns	
		5.0	1.5	6.0		

**Note 4:** Voltage Range 3.3 is 3.3V ±0.3V  
Voltage Range 5.0 is 5.0V ±0.5V

## Capacitance

Symbol	Parameter	Max	Units	Conditions
C <sub>IN</sub>	Input Capacitance	10.0	pF	V <sub>CC</sub> = Open
C <sub>PD</sub>	Power Dissipation Capacitance	50.0	pF	V <sub>CC</sub> = 5.0V



**Physical Dimensions** inches (millimeters) unless otherwise noted

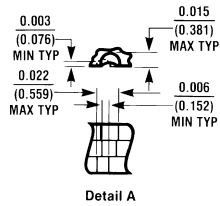
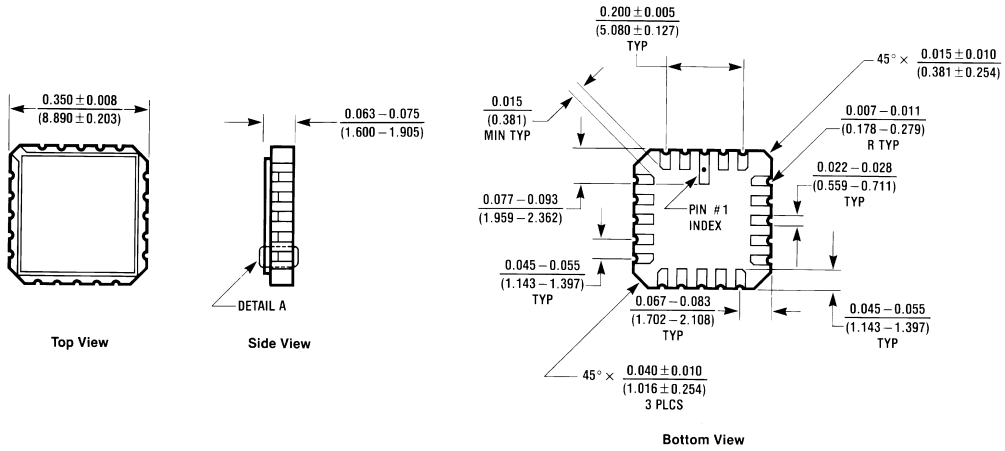

**20 Terminal Ceramic Leadless Chip Carrier (L)**  
NS Package Number E20A

E20A (REV D)

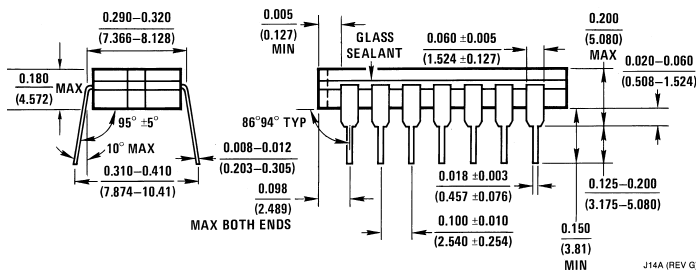
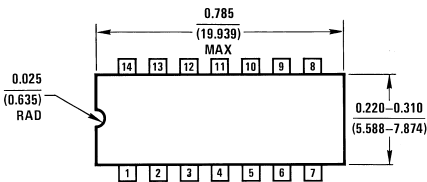

**14 Lead Ceramic Dual-In-Line Package (D)**  
NS Package Number J14A

J14A (REV G)

**Physical Dimensions** inches (millimeters) unless otherwise noted (Continued)

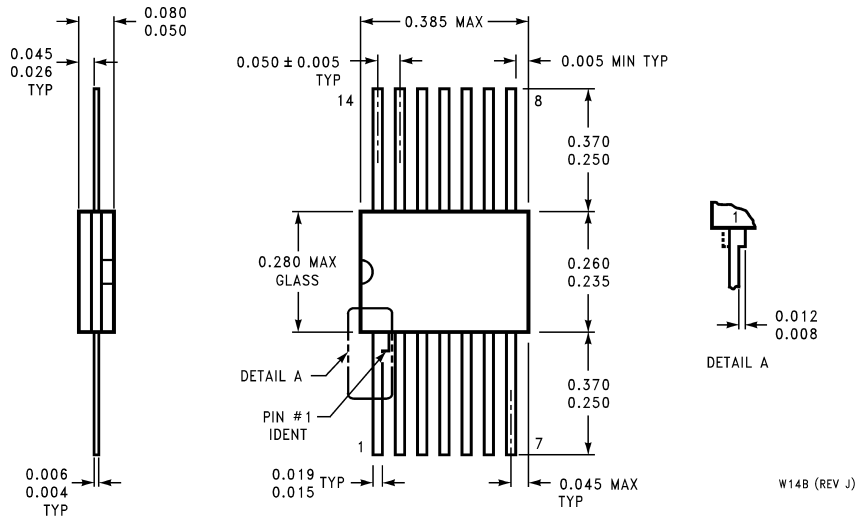

**14 Lead Ceramic Flatpak (F)  
NS Package Number W14B**

W14B (REV J)

**LIFE SUPPORT POLICY**

NATIONAL'S PRODUCTS ARE NOT AUTHORIZED FOR USE AS CRITICAL COMPONENTS IN LIFE SUPPORT DEVICES OR SYSTEMS WITHOUT THE EXPRESS WRITTEN APPROVAL OF THE PRESIDENT OF NATIONAL SEMICONDUCTOR CORPORATION. As used herein:

1. Life support devices or systems are devices or systems which, (a) are intended for surgical implant into the body, or (b) support or sustain life, and whose failure to perform when properly used in accordance with instructions for use provided in the labeling, can be reasonably expected to result in a significant injury to the user.
2. A critical component in any component of a life support device or system whose failure to perform can be reasonably expected to cause the failure of the life support device or system, or to affect its safety or effectiveness.



**National Semiconductor Corporation**  
Americas  
Tel: 1-800-272-9959  
Fax: 1-800-737-7018  
Email: support@nsc.com

**National Semiconductor Europe**  
Fax: +49 (0) 1 80-530 85 86  
Email: europe.support@nsc.com  
Deutsch Tel: +49 (0) 1 80-530 85 85  
English Tel: +49 (0) 1 80-532 78 32  
Français Tel: +49 (0) 1 80-532 93 58  
Italiano Tel: +49 (0) 1 80-534 16 80

**National Semiconductor Asia Pacific Customer Response Group**  
Tel: 65-2544466  
Fax: 65-2504466  
Email: sea.support@nsc.com

**National Semiconductor Japan Ltd.**  
Tel: 81-3-5620-6175  
Fax: 81-3-5620-6179

www.national.com