

54AC257 • 54ACT257 Quad 2-Input Multiplexer with TRI-STATE Outputs

Check for Samples: [54AC257](#), [54ACT257](#)

FEATURES

- I_{CC} and I_{OZ} Reduced by 50%
- Multiplexer Expansion by Tying Outputs Together
- Noninverting TRI-STATE Outputs
- Outputs Source/Sink 24 mA
- 'ACT257 has TTL-Compatible Inputs
- Standard Military Drawing (SMD)
 - 'AC257: 5962-88703
 - 'ACT257: 5962-89689

Logic Symbols

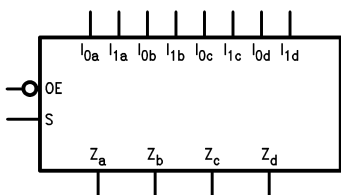

Figure 1.

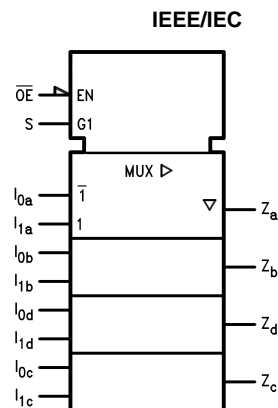

Figure 2.

PIN DESCRIPTION

Pin Names	Description
S	Common Data Select Input
\overline{OE}	TRI-STATE Output Enable Input
$I_{0a}-I_{0d}$	Data Inputs from Source 0
$I_{1a}-I_{1d}$	Data Inputs from Source 1
Z_a-Z_d	TRI-STATE Multiplexer Outputs



Please be aware that an important notice concerning availability, standard warranty, and use in critical applications of Texas Instruments semiconductor products and disclaimers thereto appears at the end of this data sheet.

FACT is a trademark of Fairchild Semiconductor.

All other trademarks are the property of their respective owners.

Connection Diagrams

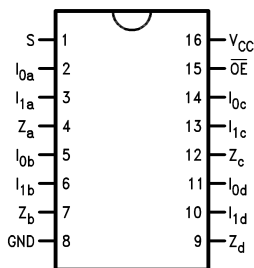

Figure 3. 16-Pin CERDIP or CLGA
See NAD0016A Package

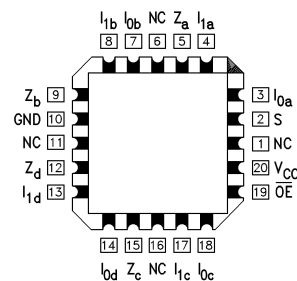

Figure 4. 20-Pin LCCC
See NAJ0020A Package

Functional Description

The 'AC/ACT257 is quad 2-input multiplexer with TRI-STATE outputs. It selects four bits of data from two sources under control of a Common Data Select input. When the Select input is LOW, the I_{0x} inputs are selected and when Select is HIGH, the I_{1x} inputs are selected. The data on the selected inputs appears at the outputs in true (noninverted) form. The device is the logic implementation of a 4-pole, 2-position switch where the position of the switch is determined by the logic levels supplied to the Select input. The logic equations for the outputs are shown below:

$$Z_a = \overline{OE} \cdot (1_{1a} \cdot S + I_{0a} \cdot \overline{S})$$

$$Z_b = \overline{OE} \cdot (1_{1b} \cdot S + I_{0b} \cdot \overline{S})$$

$$Z_c = \overline{OE} \cdot (1_{1c} \cdot S + I_{0c} \cdot \overline{S})$$

$$Z_d = \overline{OE} \cdot (1_{1d} \cdot S + I_{0d} \cdot \overline{S})$$

When the Output Enable (\overline{OE}) is HIGH, the outputs are forced to a high impedance state. If the outputs are tied together, all but one device must be in the high impedance state to avoid high currents that would exceed the maximum ratings. Designers should ensure the Output Enable signals to TRI-STATE devices whose outputs are tied together are designed so there is no overlap.

TRUTH TABLE⁽¹⁾

Output Enable	Select Input	Data Inputs		Outputs
\overline{OE}	S	I_0	I_1	Z
H	X	X	X	Z
L	H	X	L	L
L	H	X	H	H
L	L	L	X	L
L	L	H	X	H

- (1) H = HIGH Voltage Level
L = LOW Voltage Level
X = Immaterial
Z = High Impedance

Logic Diagram

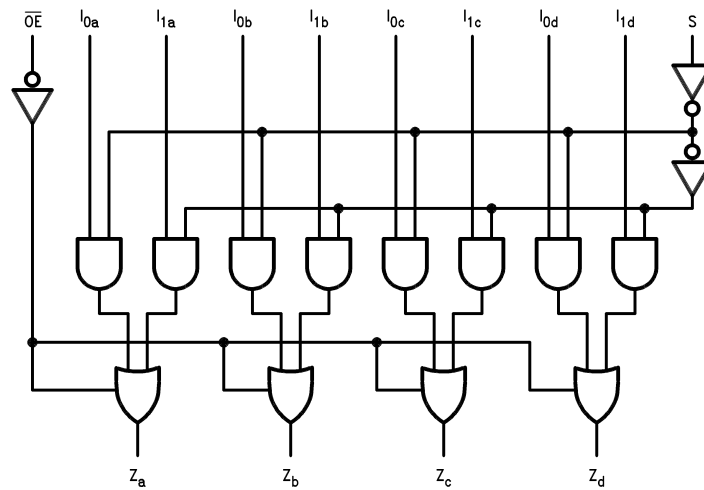

Please note that this diagram is provided only for the understanding of logic operations and should not be used to estimate propagation delays.



These devices have limited built-in ESD protection. The leads should be shorted together or the device placed in conductive foam during storage or handling to prevent electrostatic damage to the MOS gates.

ABSOLUTE MAXIMUM RATINGS ⁽¹⁾⁽²⁾

Supply Voltage (V_{CC})		-0.5V to +7.0V
DC Input Diode Current (I_{IK})	$V_I = -0.5V$	-20 mA
	$V_I = V_{CC} + 0.5V$	+20 mA
DC Input Voltage (V_I)		-0.5V to $V_{CC} + 0.5V$
DC Output Diode Current (I_{OK})	$V_O = -0.5V$	-20 mA
	$V_O = V_{CC} + 0.5V$	+20 mA
DC Output Voltage (V_O)		-0.5V to $V_{CC} + 0.5V$
DC Output Source or Sink Current (I_O)		± 50 mA
DC V_{CC} or Ground Current Per Output Pin (I_{CC} or I_{GND})		± 50 mA
Storage Temperature (T_{STG})		-65°C to +150°C
Junction Temperature (T_J)	CDIP	175°C

- (1) Absolute Maximum Ratings are those values beyond which damage to the device may occur. The databook specifications should be met, without exception, to ensure that the system design is reliable over its power supply, temperature, and output/input loading variables. Texas Instruments does not recommend operation of FACT™ circuits outside databook specifications.
- (2) If Military/Aerospace specified devices are required, please contact the Texas Instruments Sales Office/ Distributors for availability and specifications.

RECOMMENDED OPERATING CONDITIONS

Supply Voltage (V_{CC})	'AC	2.0V to 6.0V
	'ACT	4.5V to 5.5V
Input Voltage (V_I)		0V to V_{CC}
Output Voltage (V_O)		0V to V_{CC}
Operating Temperature (T_A)	54AC/ACT	-55°C to +125°C
Minimum Input Edge Rate ($\Delta V/\Delta t$) 'AC Devices	V_{IN} from 30% to 70% of V_{CC}	125 mV/ns
	V_{CC} @ 3.3V, 4.5V, 5.5V	
Minimum Input Edge Rate ($\Delta V/\Delta t$) 'ACT Devices	V_{IN} from 0.8V to 2.0V	125 mV/ns
	V_{CC} @ 4.5V, 5.5V	

DC CHARACTERISTICS FOR 'AC FAMILY DEVICES

Symbol	Parameter	V_{CC} (V)	54AC	Units	Conditions	
			$T_A =$ -55°C to +125°C			
			Ensured Limits			
V_{IH}	Minimum High Level Input Voltage	3.0	2.1	V	$V_{OUT} = 0.1V$ or $V_{CC} - 0.1V$	
		4.5	3.15			
		5.5	3.85			
V_{IL}	Maximum Low Level Input Voltage	3.0	0.9	V	$V_{OUT} = 0.1V$ or $V_{CC} - 0.1V$	
		4.5	1.35			
		5.5	1.65			
V_{OH}	Minimum High Level Output Voltage	3.0	2.9	V	$I_{OUT} = -50 \mu A$	
		4.5	4.4			
		5.5	5.4			
		3.0	2.4	V	$V_{IN} = V_{IL}$ or $V_{IH}^{(1)}$ I_{OH}	
		4.5	3.7			-12 mA
		5.5	4.7			-24 mA

- (1) All outputs loaded; thresholds on input associated with output under test.

DC CHARACTERISTICS FOR 'AC FAMILY DEVICES (continued)

Symbol	Parameter	V _{CC} (V)	54AC		Units	Conditions	
			T _A = -55°C to +125°C				
			Ensured Limits				
V _{OL}	Maximum Low Level Output Voltage	3.0	0.1		V	I _{OUT} = 50 μA	
		4.5	0.1				
		5.5	0.1				
			3.0	0.50		V	(1) V _{IN} = V _{IL} or V _{IH} I _{OL} 12 mA 24 mA 24 mA
			4.5	0.50			
			5.5	0.50			
I _{IN}	Maximum Input Leakage Current	5.5	±1.0		μA	V _I = V _{CC} , GND	
I _{OZ}	Maximum TRI-STATE Leakage Current	5.5	±10.0		μA	V _I (OE) = V _{IL} , V _{IH} V _I = V _{CC} , GND V _O = V _{CC} , GND	
I _{OLD}	⁽²⁾ Minimum Dynamic Output Current	5.5	50		mA	V _{OLD} = 1.65V Max	
I _{OHD}		5.5	-50		mA	V _{OHD} = 3.85V Min	
I _{CC}	Maximum Quiescent Supply Current	5.5	80.0		μA	V _{IN} = V _{CC} or GND	

(2) Maximum test duration 2.0 ms, one output loaded at a time.

DC CHARACTERISTICS FOR 'ACT FAMILY DEVICES

Symbol	Parameter	V _{CC} (V)	54ACT		Units	Conditions	
			T _A = -55°C to +125°C				
			Ensured Limits				
V _{IH}	Minimum High Level Input Voltage	4.5	2.0		V	V _{OUT} = 0.1V or V _{CC} - 0.1V	
		5.5	2.0				
V _{IL}	Maximum Low Level Input Voltage	4.5	0.8		V	V _{OUT} = 0.1V or V _{CC} - 0.1V	
		5.5	0.8				
V _{OH}	Minimum High Level Output Voltage	4.5	4.4		V	I _{OUT} = -50 μA	
		5.5	5.4				
			4.5	3.70		V	V _{IN} = V _{IL} or V _{IH} ⁽¹⁾ I _{OH} -24 mA -24 mA
			5.5	4.70			
V _{OL}	Maximum Low Level Output Voltage	4.5	0.1		V	I _{OUT} = 50 μA	
		5.5	0.1				
			4.5	0.50		V	V _{IN} = V _{IL} or V _{IH} ⁽¹⁾ I _{OL} 24 mA 24 mA
5.5			0.50				
I _{IN}	Maximum Input Leakage Current	5.5	±1.0		μA	V _I = V _{CC} , GND	
I _{OZ}	Maximum TRI-STATE Leakage Current	5.5	±10.0		μA	V _I = V _{IL} , V _{IH} V _O = V _{CC} , GND	
I _{CCT}	Maximum I _{CC} /Input	5.5	1.6		mA	V _I = V _{CC} - 2.1V	
I _{OLD}	Minimum Dynamic Output Current ⁽²⁾	5.5	50		mA	V _{OLD} = 1.65V Max	
I _{OHD}		5.5	-50		mA	V _{OHD} = 3.85V Min	
I _{CC}	Maximum Quiescent Supply Current	5.5	80.0		μA	V _{IN} = V _{CC} or GND	

(1) All outputs loaded; thresholds on input associated with output under test.

(2) Maximum test duration 2.0 ms, one output loaded at a time.

AC ELECTRICAL CHARACTERISTICS

Symbol	Parameter	V _{CC} (V) ⁽¹⁾	54AC		Units
			T _A = -55°C to +125°C C _L = 50 pF		
t _{PLH}	Propagation Delay I _n to Z _n	3.3	1.0	11.0	ns
		5.0	1.0	8.0	
t _{PHL}	Propagation Delay I _n to Z _n	3.3	1.0	11.0	ns
		5.0	1.0	8.5	
t _{PLH}	Propagation Delay S to Z _n	3.3	1.0	14.5	ns
		5.0	1.0	11.0	
t _{PHL}	Propagation Delay S to Z _n	3.3	1.0	14.5	ns
		5.0	1.0	11.0	
t _{PZH}	Output Enable Time	3.3	1.0	13.0	ns
		5.0	1.0	10.0	
t _{PZL}	Output Enable Time	3.3	1.0	11.0	ns
		5.0	1.0	9.5	
t _{PHZ}	Output Disable Time	3.3	1.0	13.0	ns
		5.0	1.0	11.0	
t _{PLZ}	Output Disable Time	3.3	1.0	10.5	ns
		5.0	1.0	9.5	

(1) Voltage Range 3.3 is 3.0V ±0.3V. Voltage Range 5.0 is 5.0V ±0.5V.

AC ELECTRICAL CHARACTERISTICS

Symbol	Parameter	V _{CC} (V) ⁽¹⁾	54ACT		Units
			T _A = -55°C to +125°C C _L = 50 pF		
t _{PLH}	Propagation Delay I _n to Z _n	5.0	1.0	8.0	ns
t _{PHL}	Propagation Delay I _n to Z _n	5.0	1.0	9.5	ns
t _{PLH}	Propagation Delay S to Z _n	5.0	1.0	11.0	ns
t _{PHL}	Propagation Delay S to Z _n	5.0	1.0	11.5	ns
t _{PZH}	Output Enable Time	5.0	1.0	9.5	ns
t _{PZL}	Output Enable Time	5.0	1.0	9.5	ns
t _{PHZ}	Output Disable Time	5.0	1.0	10.5	ns
t _{PLZ}	Output Disable Time	5.0	1.0	9.5	ns

(1) Voltage Range 5.0 is 5.0V ±0.5V.

CAPACITANCE

Symbol	Parameter	Typ	Units	Conditions
C _{IN}	Input Capacitance	4.5	pF	V _{CC} = OPEN
C _{PD}	Power Dissipation Capacitance	50.0	pF	V _{CC} = 5.0V

REVISION HISTORY

Changes from Revision A (April 2013) to Revision B	Page
<hr/> <ul style="list-style-type: none">• Changed layout of National Data Sheet to TI format	<hr/> 6

IMPORTANT NOTICE

Texas Instruments Incorporated and its subsidiaries (TI) reserve the right to make corrections, enhancements, improvements and other changes to its semiconductor products and services per JESD46, latest issue, and to discontinue any product or service per JESD48, latest issue. Buyers should obtain the latest relevant information before placing orders and should verify that such information is current and complete. All semiconductor products (also referred to herein as "components") are sold subject to TI's terms and conditions of sale supplied at the time of order acknowledgment.

TI warrants performance of its components to the specifications applicable at the time of sale, in accordance with the warranty in TI's terms and conditions of sale of semiconductor products. Testing and other quality control techniques are used to the extent TI deems necessary to support this warranty. Except where mandated by applicable law, testing of all parameters of each component is not necessarily performed.

TI assumes no liability for applications assistance or the design of Buyers' products. Buyers are responsible for their products and applications using TI components. To minimize the risks associated with Buyers' products and applications, Buyers should provide adequate design and operating safeguards.

TI does not warrant or represent that any license, either express or implied, is granted under any patent right, copyright, mask work right, or other intellectual property right relating to any combination, machine, or process in which TI components or services are used. Information published by TI regarding third-party products or services does not constitute a license to use such products or services or a warranty or endorsement thereof. Use of such information may require a license from a third party under the patents or other intellectual property of the third party, or a license from TI under the patents or other intellectual property of TI.

Reproduction of significant portions of TI information in TI data books or data sheets is permissible only if reproduction is without alteration and is accompanied by all associated warranties, conditions, limitations, and notices. TI is not responsible or liable for such altered documentation. Information of third parties may be subject to additional restrictions.

Resale of TI components or services with statements different from or beyond the parameters stated by TI for that component or service voids all express and any implied warranties for the associated TI component or service and is an unfair and deceptive business practice. TI is not responsible or liable for any such statements.

Buyer acknowledges and agrees that it is solely responsible for compliance with all legal, regulatory and safety-related requirements concerning its products, and any use of TI components in its applications, notwithstanding any applications-related information or support that may be provided by TI. Buyer represents and agrees that it has all the necessary expertise to create and implement safeguards which anticipate dangerous consequences of failures, monitor failures and their consequences, lessen the likelihood of failures that might cause harm and take appropriate remedial actions. Buyer will fully indemnify TI and its representatives against any damages arising out of the use of any TI components in safety-critical applications.

In some cases, TI components may be promoted specifically to facilitate safety-related applications. With such components, TI's goal is to help enable customers to design and create their own end-product solutions that meet applicable functional safety standards and requirements. Nonetheless, such components are subject to these terms.

No TI components are authorized for use in FDA Class III (or similar life-critical medical equipment) unless authorized officers of the parties have executed a special agreement specifically governing such use.

Only those TI components which TI has specifically designated as military grade or "enhanced plastic" are designed and intended for use in military/aerospace applications or environments. Buyer acknowledges and agrees that any military or aerospace use of TI components which have **not** been so designated is solely at the Buyer's risk, and that Buyer is solely responsible for compliance with all legal and regulatory requirements in connection with such use.

TI has specifically designated certain components as meeting ISO/TS16949 requirements, mainly for automotive use. In any case of use of non-designated products, TI will not be responsible for any failure to meet ISO/TS16949.

Products

Audio	www.ti.com/audio
Amplifiers	amplifier.ti.com
Data Converters	dataconverter.ti.com
DLP® Products	www.dlp.com
DSP	dsp.ti.com
Clocks and Timers	www.ti.com/clocks
Interface	interface.ti.com
Logic	logic.ti.com
Power Mgmt	power.ti.com
Microcontrollers	microcontroller.ti.com
RFID	www.ti-rfid.com
OMAP Applications Processors	www.ti.com/omap
Wireless Connectivity	www.ti.com/wirelessconnectivity

Applications

Automotive and Transportation	www.ti.com/automotive
Communications and Telecom	www.ti.com/communications
Computers and Peripherals	www.ti.com/computers
Consumer Electronics	www.ti.com/consumer-apps
Energy and Lighting	www.ti.com/energy
Industrial	www.ti.com/industrial
Medical	www.ti.com/medical
Security	www.ti.com/security
Space, Avionics and Defense	www.ti.com/space-avionics-defense
Video and Imaging	www.ti.com/video

TI E2E Community

e2e.ti.com