

Low voltage CMOS 16-bit bus buffer (3-state non inverter) with 3.6 V tolerant inputs and outputs



FLAT-48
The upper metallic lid is internally connected to ground

Features

- 1.8 to 3.6 V operating voltage
- 5 ns propagation delay
- 100 mV typical input hysteresis
- Power down protection on inputs and outputs
- Symmetrical output impedance
- 26 Ω series resistance in outputs
- Bus hold on data inputs
- Cold spare function
- Latch-up performance exceeds 300 mA (JESD 17)
- 300 krad(Si) total ionizing dose (TID)
- No SEL, no SEU and no SET at 110 MeV.cm²/mg LET
- QML-V qualified
- SMD 5962F05210

Description

The 54VCXH162244 is a low voltage CMOS 16-bit bus buffer (non inverted) fabricated with submicron silicon gate and five-layer metal wiring C²MOS technology. It is ideal for low power and very high speed 1.8 V to 3.6 V applications; it can be interfaced to 3.6 V signal environment for both inputs and outputs. Any nG output control governs four BUS buffers. Output enable input (nG) tied together gives full 16-bit operation. When nG is low, the outputs are on. When nG is high, the output are in high impedance state. This device is designed to be used with 3-state memory address drivers, etc. Bus hold on data inputs is provided in order to eliminate the need for external pull-up or pull-down resistor. The device circuits is including 26 Ω series resistance in the outputs. These resistors permit to reduce line noise in high speed applications. All inputs and outputs are equipped with protection circuits against static discharge, giving them 2 kV ESD immunity and transient excess voltage.

Product status link

[54VCXH162244](#)

1 Logic symbols and I/O equivalent circuit

Figure 1. IEC logic symbols

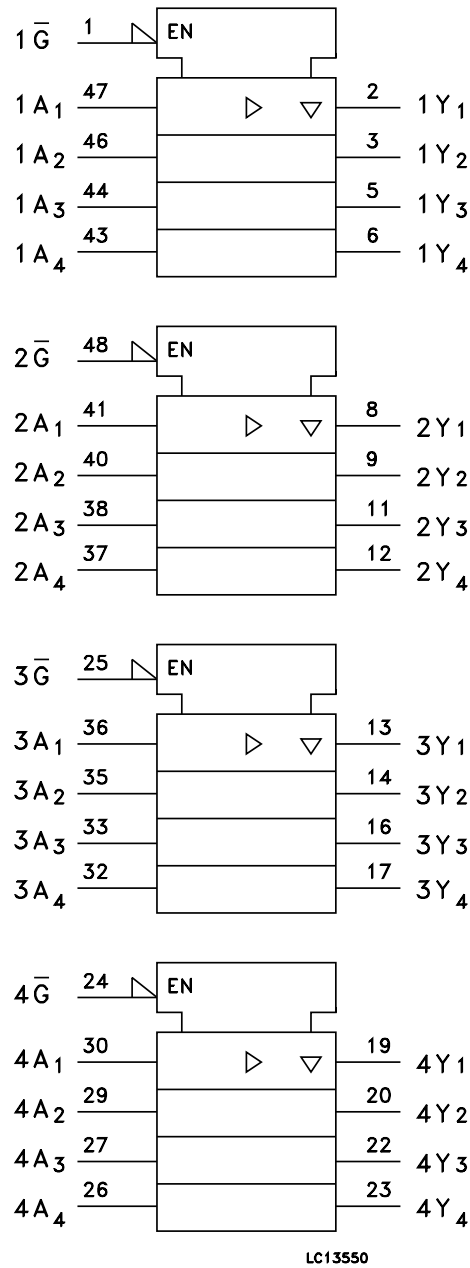
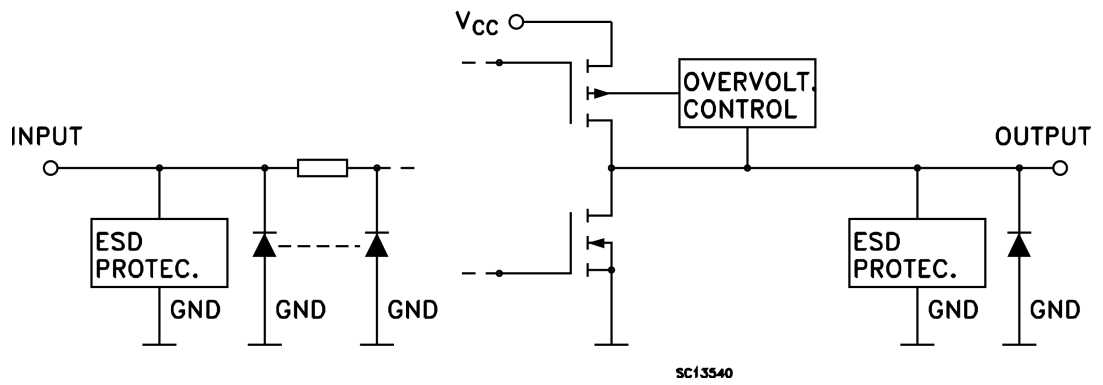

Figure 2. Input and output equivalent circuit



2 Pin settings

2.1 Pin connection

Figure 3. Pin connection (top through view)

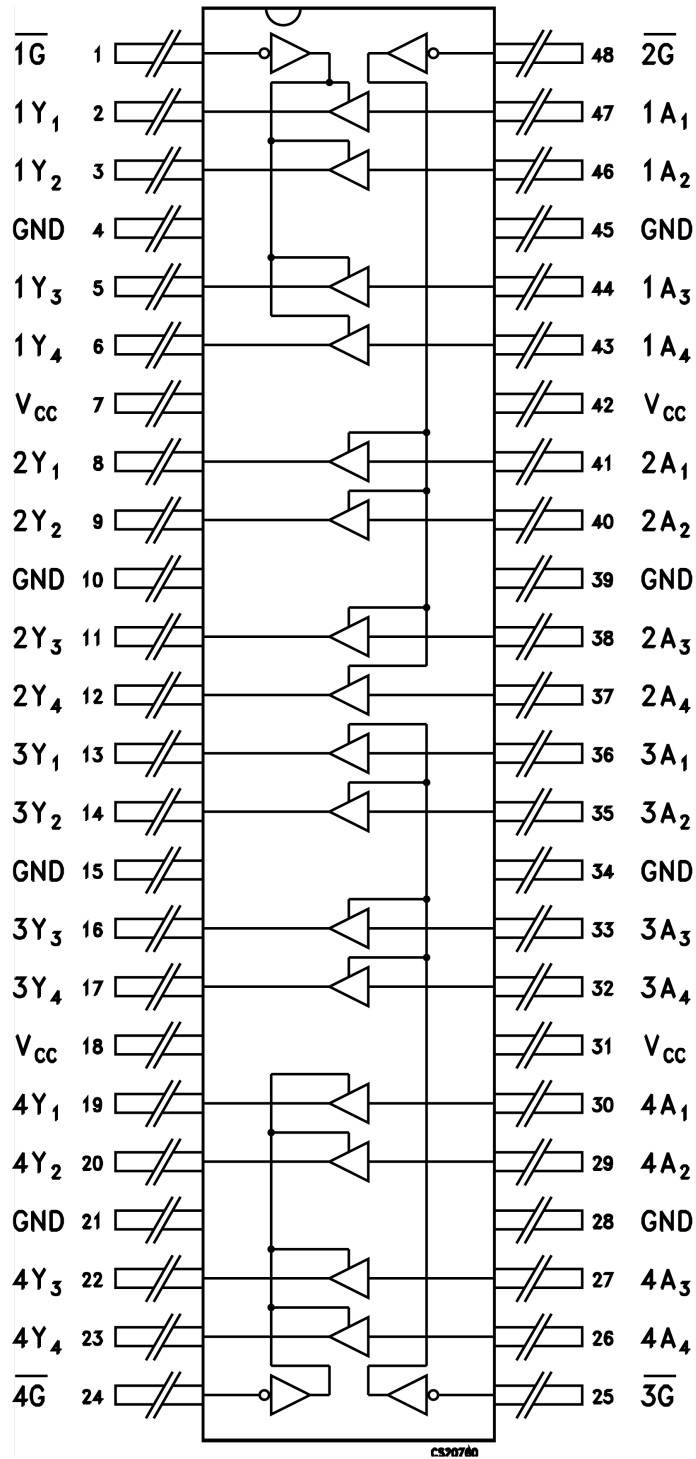

2.2 Pin description

Table 1. Pin description

Pin	Symbol	Name and function
1	$1\bar{G}$	Output enable input
2, 3, 5, 6	1Y1 to 1Y4	Data outputs
8, 9, 11, 12	2Y1 to 2Y4	Data outputs
13, 14, 16, 17	3Y1 to 3Y4	Data outputs
19, 20, 22, 23	4Y1 to 4Y4	Data outputs
24	$4\bar{G}$	Output enable input
25	$3\bar{G}$	Output enable input
30, 29, 27, 26	4A1 to 4A4	Data outputs
36, 35, 33, 32	3A1 to 3A4	Data outputs
41, 40, 38, 37	2A1 to 2A4	Data outputs
47, 46, 44, 43	1A1 to 1A4	Data outputs
48	$2\bar{G}$	Output enable input
4, 10, 15, 21, 28, 34, 39, 45	GND	Ground (0 V)
7, 18, 31, 42	VCC	Positive supply voltage

2.3 Truth table

Table 2. Truth table

Inputs		Outputs
G	An	Yn
L	L	L
L	H	H
H	X	Z

X = do not care; Z = high impedance

3 Maximum ratings

Stressing the device above the rating listed in the “absolute maximum ratings” table may cause permanent damage to the device. These are stress ratings only and operation of the device at these or any other conditions above those indicated in the operating sections of this specification is not implied. Exposure to absolute maximum rating conditions for extended periods may affect device reliability.

Table 3. Absolute maximum ratings

Symbol	Parameter	Value	Unit
V_{CC}	Supply voltage	-0.5 to +4.6	V
V_I	DC input voltage	-0.5 to +4.6	V
V_O	DC output voltage (OFF-state) ⁽¹⁾	-0.5 to +4.6	V
V_O	DC output voltage (high or low-state)	-0.5 to $V_{CC} + 0.5$	V
I_{IK}	DC input diode current	-50	mA
I_{OK}	DC output diode current ⁽²⁾	-50	mA
I_O	DC output current	±50	mA
I_{CC} or I_{GND}	DC V_{CC} or ground current per supply pin	±100	mA
P_D	Power dissipation	400	mW
T_{stg}	Storage temperature	-65 to +150	°C
T_L	Lead temperature (10 s)	260	°C
R_{thjc}	Thermal resistance junction-to-case ⁽³⁾	22	°C/W
ESD	HBM: human body model ⁽⁴⁾	2	kV

- I_O absolute maximum rating must be observed.
- $V_O < GND$, $V_O > V_{CC}$.
- Short-circuits can cause excessive heating and destructive dissipation. Values are typical.
- Human body model: a 100 pF capacitor is charged to the specified voltage, then discharged through a 1.5 kΩ resistor between two pins of the device. This is done for all couples of connected pin combinations while the other pins are floating.

3.1 Recommended conditions

Table 4. Recommended operating conditions

Symbol	Parameter	Value	Unit
V_{CC}	Supply voltage	1.8 to 3.6	V
V_I	Input voltage	-0.3 to 3.6	V
V_O	Output voltage (OFF-state)	0 to 3.6	V
V_O	Output voltage (high or low-state)	0 to V_{CC}	V
I_{OH}, I_{OL}	High or low level output current ($V_{CC} = 3.0$ to 3.6 V)	± 12	mA
I_{OH}, I_{OL}	High or low level output current ($V_{CC} = 2.3$ to 2.7 V)	± 8	mA
T_{op}	Operating temperature	-55 to 125	$^{\circ}C$
dt/dv	Input rise and fall time ⁽¹⁾	0 to 10	ns/V

1. V_{IN} from 0.8 V to 2 V at $V_{CC} = 3.0$ V.

4 Electrical characteristics

Table 5. DC specifications

Symbol	Parameter	Test conditions		Value		Unit
		V _{CC} (V)		-55 to 125 °C		
				Min.	Max.	
V _{IH}	High level input voltage	2.7 to 3.6		2.0		V
V _{IL}	Low level input voltage			0.8		
V _{OH}	High level output voltage	2.7 to 3.6	I _O = -100 μA	V _{CC} -0.2		V
		2.7	I _O = -6 mA	2.2		
		3.0	I _O = -8 mA	2.4		
			I _O = -12 mA	2.2		
V _{OL}	Low level output voltage	2.7 to 3.6	I _O = 100 μA		0.2	V
		2.7	I _O = 6 mA		0.4	
		3	I _O = 8 mA		0.5	
			I _O = 12 mA		0.8	
I _I	Input leakage current	2.7 to 3.6	V _I = V _{CC} or GND		±5	μA
I _{I(HOLD)}	Input hold current	3	V _I = 0.8 V	75		μA
			V _I = 2 V	-75		
		3.6	V _I = 0 to 3.6 V		±500	
I _{off}	Power off leakage current	0	V _I or V _O = 0 to 3.6 V		10	μA
I _{OZ}	High impedance output leakage current	2.7 to 3.6	V _I = V _{IH} or V _{IL} , V _O = 0 to 3.6 V		±10	μA
I _{CC}	Quiescent supply current	2.7 to 3.6	V _I = V _{CC} or GND		20	μA
			V _I or V _O = V _{CC} to 3.6 V		±20	μA
ΔI _{CC}	I _{CC} incr. per input	2.7 to 3.6	V _{IH} = V _{CC} - 0.6 V		750	μA

Table 6. DC specifications

Symbol	Parameter	Test conditions		Value		Unit
		V _{CC} (V)		-55 to 125 °C		
				Min.	Max.	
V _{IH}	High level input voltage	2.3		1.6		V
		1.8		1.2		
V _{IL}	Low level input voltage	2.3			0.7	
		1.8			0.4	
V _{OH}	High level output voltage	2.3	I _O = -6 mA	1.8		V
			I _O = -8 mA	1.7		
		1.8	I _O = -4 mA	1.4		
V _{OL}	Low level output voltage	2.3	I _O = 6 mA		0.4	V
			I _O = 8 mA		0.6	
		1.8	I _O = 4 mA		0.3	

Table 7. Dynamic switching characteristics

Symbol	Parameter	Test conditions		Value		Unit
		V _{CC} (V)		Min.	Max.	
V _{OLP}	Low level V _{CC} bounce noise ⁽¹⁾⁽²⁾	3.3	V _{IL} = 0 V, V _{IH} = V _{CC} C _L = 30 pF, R _L = 500 ohm 25°C		500	mV
V _{OLV}					-350	
V _{OHP}	High level V _{CC} bounce noise ⁽²⁾⁽³⁾	3.3			850	mV
V _{OHV}					-1050	

1. Number of outputs defined as "n". Measured with "n-1" output switching from HIGH to LOW or LOW to HIGH. The remaining output is measured in the LOW state.
2. Parameters guaranteed by design.
3. Number of outputs defined as "n". Measured with "n-1" outputs switching from HIGH to LOW or LOW to HIGH. The remaining output is measured in the HIGH state.

Table 8. AC electrical characteristics

Symbol	Parameter	Test conditions		Value		Unit
		V _{CC} (V)		-55 to 125 °C		
				Min.	Max.	
t _{PLH} , t _{PHL}	Propagation delay time	3.6	C _L = 30 pF, R _L = 500 ohm tr = tf = 2 ns	0.8	5	ns
		2.3		1	5.2	
		1.8		1	8.2	
t _{PZL} , t _{PZH}	Output enable time	3.6		0.8	4.2	ns
		2.3		1	5.8	
		1.8		1	8.7	
t _{PLZ} , t _{PHZ}	Output disable time	3.6		0.8	4	ns
		2.3		1	4.5	
		1.8		1	5.8	

Table 9. Capacitive characteristics

Symbol	Parameter	Test conditions		Value		Unit
		V _{CC} (V)		Min.	Max.	
C _{IN}	Input capacitance	GND	25°C		10	pF
C _{OUT}	Output capacitance	3.3	25°C		12	pF
C _{PD}	Power dissipation capacitance ⁽¹⁾	3.3	25 °C, F=1 MHz		80	pF

1. CPD is defined as the value of the IC's internal equivalent capacitance which is calculated from the operating current consumption without load. (Refer to test circuit). Average operating current can be obtained by the following equation.
 $I_{CC(opr)} = C_{PD} \times V_{CC} \times f_{IN} + I_{CC}/16$ (per circuit).

5 Test circuit

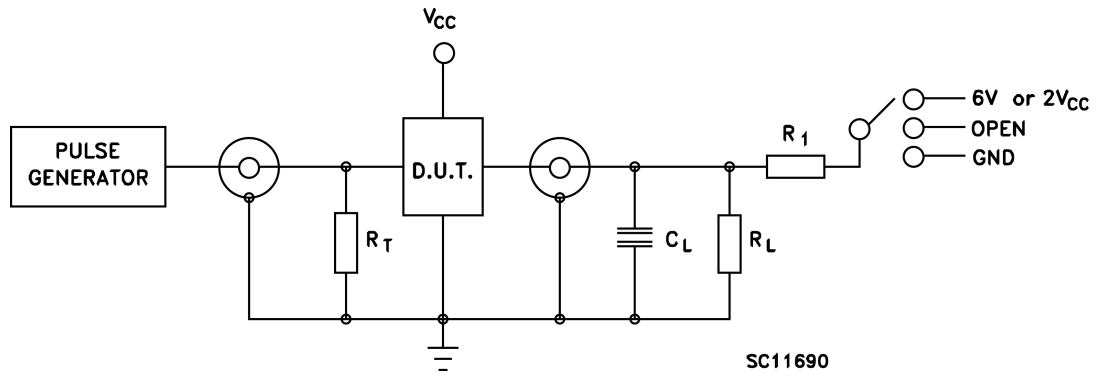
Figure 4. Application circuit

Table 10. Test circuit

Symbol	V _{CC}	
	1.8 V and 2.3 V to 2.7 V	3.0 v to 3.6 V
V _{IH}	V _{CC}	2.7 V
V _M	V _{CC/2}	1.5 V
V _X	V _{OL} + 0.15 V	V _{OL} + 0.3 V
V _Y	V _{OH} - 0.15 V	V _{OH} - 0.3 V

C_L = 30 pF or equivalent (includes jig and probe capacitance)

R_L = R₁ = 500 Ω or equivalent

R_T = Z_{OUT} of pulse generator (typically 50 Ω)

6 Waveforms

Figure 5. Waveform - propagation delay ($f = 1\text{ MHz}$; 50% duty cycle)

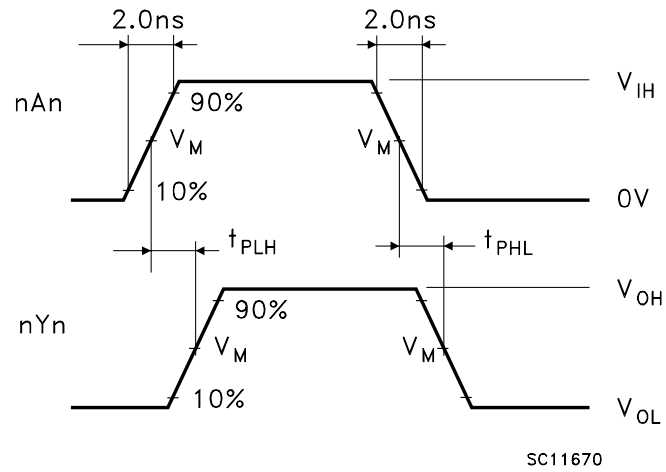
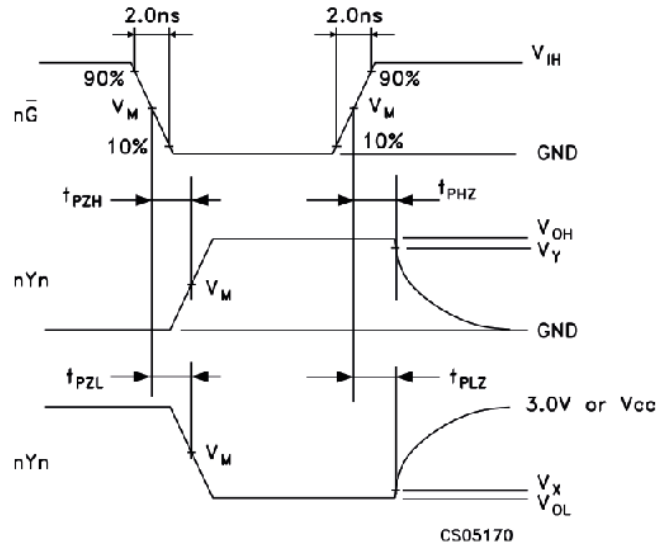

Figure 6. Waveform - output enable and disable time ($f = 1\text{ MHz}$; 50% duty cycle)



7 Package information

In order to meet environmental requirements, ST offers these devices in different grades of **ECOPACK** packages, depending on their level of environmental compliance. ECOPACK specifications, grade definitions and product status are available at: www.st.com. ECOPACK is an ST trademark.

7.1 FLAT-48 package information

Figure 7. FLAT-48 package outline

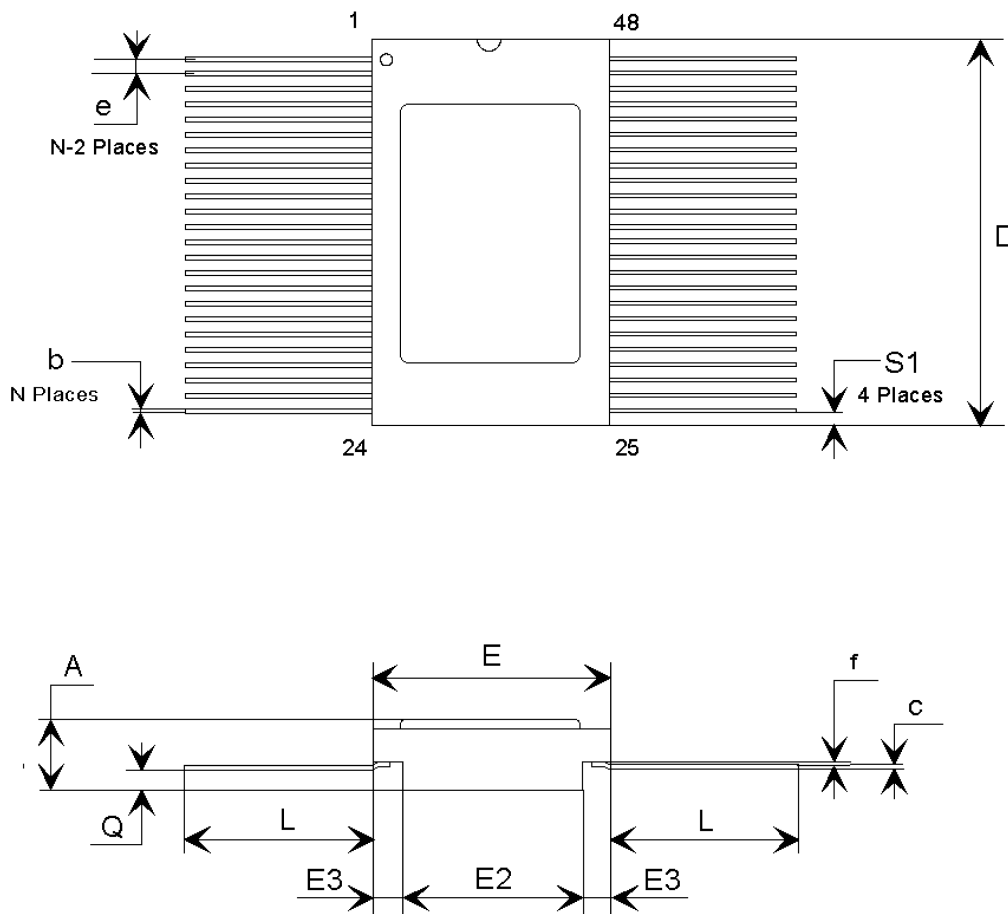

Note: The upper metallic lid is internally connected to ground

Table 11. FLAT-48 package mechanical data

Symbol	mm			Inches ⁽¹⁾		
	Min.	Typ.	Max.	Min.	Typ.	Max.
A	2.18	2.47	2.72	.086	.097	.107
b	0.20	0.254	0.30	.008	.010	.012
c	0.12	0.15	0.18	.005	.006	.007
D	15.57	15.75	15.92	.613	.620	.627
E	9.52	9.65	9.78	.375	.380	.385
E2	6.22	6.35	6.48	.245	.250	.255
E3	1.52	1.65	1.78	.060	.065	.070
e		0.635			.025	
f		0.20			.008	
L	6.85	8.38	9.40	.270	.330	.370
Q	0.66	0.79	0.92	.026	.031	.036
S1	0.25	0.43	0.61	.010	.017	.024

1. Values in inches are converted from mm and rounded to 4 decimal digits.

8 Ordering information

Order code	SMD ⁽¹⁾	Qualification level	Mass	Package	Lead finish	Marking ⁽²⁾	Packing
RHFXH162244K1	-	Engineering model	1.5 g	Flat-48	Gold	RHFXH162244K1	Conductive strip pack
RHFXH162244K03V	5962F05210	QML-V Flight		Flat-48 with grounded lid		5962F0521002VXC	
RHFXH162244K05V	5962F05210	QML-V Flight				5962F0521002VYC	

1. Standard microcircuit drawing

2. Specific marking only. Complete marking includes the following:

- ST logo
- Date code (date the package was sealed) in YYWWA (year, week, and lot index of week)

Other information

Date code:

The date code is structured as engineering model: EM xyywwz

Where:

x = 3 (EM only), assembly location Rennes (France)

yy = last two digits of the year

ww = week digits

z = lot index of the week

Product documentation

Each product shipment includes a set of associated documentation within the shipment box. This documentation depends on the quality level of the products, as detailed in the table below.

The certificate of conformance is provided on paper whatever the quality level. For QML parts, complete documentation, including the certificate of conformance, is provided on a CDROM.

Table 12. Product documentation

Quality level	Item
Engineering model	Certificate of conformance including : Customer name Customer purchase order number ST sales order number and item ST part number Quantity delivered Date code Reference to ST datasheet Reference to TN1181 on engineering models ST Rennes assembly lot ID
QML-V Flight	Certificate of Conformance including: Customer name Customer purchase order number ST sales order number and item ST part number Quantity delivered Date code Serial numbers

Quality level	Item
QML-V Flight	Group C reference
	Group D reference
	Reference to the applicable SMD
	ST Rennes assembly lot ID
	Quality control inspection (groups A, B, C, D, E)
	Screening electrical data in/out summary
	Precap report
	PIND (particle impact noise detection) test
	SEM (scanning electronic microscope) inspection report
	X-ray plates

Revision history

Table 13. Document revision history

Date	Version	Changes
09-Jul-2004	1	Initial release.
17-May-2005	2	SMD qualified
19-Jun-2006	3	300 krad bullet updated, new template, mechanical data updated
11-Apr-2007	4	Updated cover page features
30-Jul-2007	5	Typo in Table 12 on page 14
17-Sep-2008	6	Updated cover page
09-Jan-2009	7	Updated cover page
23-Sep-2009	8	Updated Table 13 on page 16
29-Jul-2011	9	Added Note: on page 15 and in the "Pin connections" diagram on the cover page.
11-Jun-2019	10	Updated cover image, Section 7.1: FLAT-48 package information and Section 8: Ordering information.
22-Jan-2024	11	Updated figure and features on the cover page. Updated Table 6. DC specifications , Table 7. Dynamic switching characteristics, Table 8. AC electrical characteristics, Table 10, Section 8: Ordering information.

Contents

1	Logic symbols and I/O equivalent circuit	2
2	Pin settings	4
2.1	Pin connection	4
2.2	Pin description	5
2.3	Truth table	5
3	Maximum ratings	6
3.1	Recommended conditions	7
4	Electrical characteristics	8
5	Test circuit	10
6	Waveforms	11
7	Package information	12
7.1	FLAT-48 package information	12
8	Ordering information	14
	Revision history	16

List of tables

Table 1.	Pin description	5
Table 2.	Truth table	5
Table 3.	Absolute maximum ratings	6
Table 4.	Recommended operating conditions	7
Table 5.	DC specifications	8
Table 6.	DC specifications	8
Table 7.	Dynamic switching characteristics	9
Table 8.	AC electrical characteristics	9
Table 9.	Capacitive characteristics	9
Table 10.	Test circuit	10
Table 11.	FLAT-48 package mechanical data	13
Table 12.	Product documentation	14
Table 13.	Document revision history	16

List of figures

Figure 1.	IEC logic symbols	2
Figure 2.	Input and output equivalent circuit	3
Figure 3.	Pin connection (top through view)	4
Figure 4.	Application circuit	10
Figure 5.	Waveform - propagation delay (f = 1 MHz; 50% duty cycle)	11
Figure 6.	Waveform - output enable and disable time (f = 1 MHz; 50% duty cycle)	11
Figure 7.	FLAT-48 package outline	12

IMPORTANT NOTICE – READ CAREFULLY

STMicroelectronics NV and its subsidiaries (“ST”) reserve the right to make changes, corrections, enhancements, modifications, and improvements to ST products and/or to this document at any time without notice. Purchasers should obtain the latest relevant information on ST products before placing orders. ST products are sold pursuant to ST’s terms and conditions of sale in place at the time of order acknowledgment.

Purchasers are solely responsible for the choice, selection, and use of ST products and ST assumes no liability for application assistance or the design of purchasers’ products.

No license, express or implied, to any intellectual property right is granted by ST herein.

Resale of ST products with provisions different from the information set forth herein shall void any warranty granted by ST for such product.

ST and the ST logo are trademarks of ST. For additional information about ST trademarks, refer to www.st.com/trademarks. All other product or service names are the property of their respective owners.

Information in this document supersedes and replaces information previously supplied in any prior versions of this document.

© 2024 STMicroelectronics – All rights reserved