

1.8°57mm

混合式丝杆步进电机参数 Hybrid Linear Stepper Motor



性能规格书 The Performance Specification

Item	Specifications	
电机型号 Model	57HS1405-XXNE	
步距角 Step Angle	1.8°	
绕组类型 Winding Type	2 poles	
相电流 Rated Current (A)	2	
相电阻 Resistance (Ω)	2	
功耗 Power Consume(W)	13	
转子惯量 Rotor Inertia (g.cm ²)	38	
温升 Temperature Rise(°C)	75	

丝杆规格书 The Leadscrew Specification

Φ9.53				
导程 Helical Pitch		步长 Step Length		步长代码 Step Length Code
in.	mm	in.	mm	
0.125	3.175	0.00062	0.01587	U
1.0	25.4	0.005	0.127	Z

The helical pitch can be customized.

1.8°57mm

混合式丝杆步进电机参数 Hybrid Linear Stepper Motor

尺寸图 Mechanical Dimensions

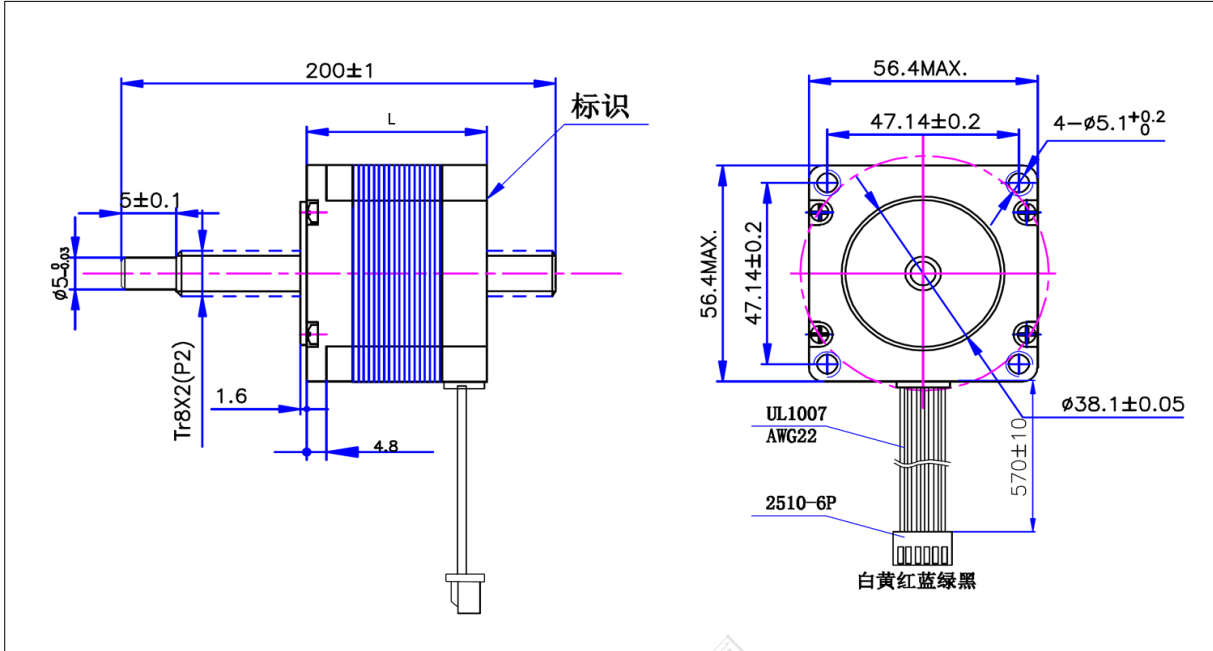

重庆优摩特科技有限公司