



5N40-CB

Preliminary

Power MOSFET

5.0A, 400V N-CHANNEL POWER MOSFET

DESCRIPTION

The UTC **5N40** is an N-channel mode power MOSFET using UTC's advanced technology to provide customers with planar stripe and DMOS technology. This technology specializes in allowing a minimum on-state resistance and superior switching performance. It also can withstand high energy pulse in the avalanche and commutation mode.

The UTC **5N40** is universally applied in electronic lamp ballast based on half bridge topology and high efficient switched mode power supply.

FEATURES

- * $R_{DS(ON)} < 1.0\Omega @ V_{GS} = 10V, I_D = 2.5A$
- * High Switching Speed
- * 100% Avalanche Tested

SYMBOL

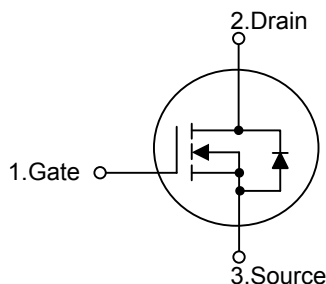

ORDERING INFORMATION

Ordering Number		Package	Pin Assignment			Packing
Lead Free	Halogen Free		1	2	3	
5N40L-TA3-T	5N40G-TA3-T	TO-220	G	D	S	Tube
5N40L-TF1-T	5N40G-TF1-T	TO-220F1	G	D	S	Tube
5N40L-TF2-T	5N40G-TF2-T	TO-220F2	G	D	S	Tube
5N40L-TF3-T	5N40G-TF3-T	TO-220F	G	D	S	Tube
5N40L-TM3-R	5N40G-TM3-R	TO-251	G	D	S	Tape Reel
5N40L-TN3-R	5N40G-TN3-R	TO-252	G	D	S	Tape Reel

Note: Pin Assignment: G: Gate D: Drain S: Source

<p>5N40L-TA3-T</p>	<p>(1) T: Tube, R: Tape Reel</p> <p>(2) TA3: TO-220, TF3: TO-220F, TF1: TO-220F1, TF2: TO-220F2, TM3: TO-251, TN3: TO-252</p> <p>(3) L: Lead Free, G: Halogen Free and Lead Free</p>
--------------------	--

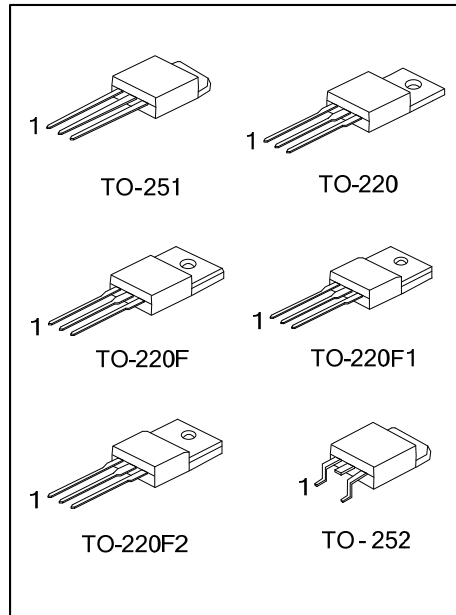

MARKING

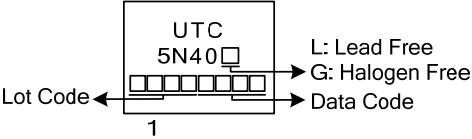

■ ABSOLUTE MAXIMUM RATINGS ($T_C=25^\circ\text{C}$, unless otherwise specified)

PARAMETER		SYMBOL	RATINGS	UNIT
Drain-Source Voltage		V_{DSS}	400	V
Gate-Source Voltage		V_{GSS}	± 30	V
Drain Current ($T_C=25^\circ\text{C}$)	Continuous	I_D	5	A
	Pulsed (Note 2)	I_{DM}	20	A
Avalanche Current (Note 2)		I_{AR}	4.5	A
Avalanche Energy	Single Pulsed (Note 3)	E_{AS}	131	mJ
Peak Diode Recovery dv/dt (Note 4)		dv/dt	4.5	V/ns
Power Dissipation ($T_C=25^\circ\text{C}$)	TO-220	P_D	69	W
	TO-220F/TO-220F1		38	W
	TO-220F2			
	TO-251/TO-252			
Junction Temperature		T_J	+150	$^\circ\text{C}$
Storage Temperature		T_{STG}	-55 ~ +150	$^\circ\text{C}$

Notes: 1. Absolute maximum ratings are those values beyond which the device could be permanently damaged.

Absolute maximum ratings are stress ratings only and functional device operation is not implied.

2. Repetitive Rating: Pulse width limited by maximum junction temperature.

3. $L = 13 \text{ mH}$, $I_{AS} = 4.5 \text{ A}$, $V_{DD} = 50 \text{ V}$, $R_G = 25 \Omega$, Starting $T_J = 25^\circ\text{C}$

4. $I_{SD} \leq 5.0 \text{ A}$, $di/dt \leq 200 \text{ A}/\mu\text{s}$, $V_{DD} \leq BV_{DSS}$, Starting $T_J = 25^\circ\text{C}$

■ THERMAL DATA

PARAMETER	PACKAGE	SYMBOL	RATINGS	UNIT
Junction to Ambient	TO-220/TO-220F	θ_{JA}	62.5	$^\circ\text{C}/\text{W}$
	TO-220F1/TO-220F2			
	TO-251/TO-252			
Junction to Case	TO-220	θ_{JC}	1.8	$^\circ\text{C}/\text{W}$
	TO-220F/TO-220F1		3.3	$^\circ\text{C}/\text{W}$
	TO-220F2			
	TO-251/TO-252		2.3	$^\circ\text{C}/\text{W}$

■ ELECTRICAL CHARACTERISTICS ($T_c=25^\circ\text{C}$, unless otherwise noted)

PARAMETER	SYMBOL	TEST CONDITIONS	MIN	TYP	MAX	UNIT
OFF CHARACTERISTICS						
Drain-Source Breakdown Voltage	BV_{DSS}	$I_D=250\mu\text{A}$, $V_{GS}=0\text{V}$	400			V
Drain-Source Leakage Current	I_{DSS}	$V_{DS}=400\text{V}$, $V_{GS}=0\text{V}$			1	μA
Gate- Source Leakage Current	Forward	I_{GSS}			+100	nA
	Reverse				-100	nA
ON CHARACTERISTICS						
Gate Threshold Voltage	$V_{GS(TH)}$	$V_{DS}=V_{GS}$, $I_D=250\mu\text{A}$	2.0		4.0	V
Static Drain-Source On-State Resistance	$R_{DS(ON)}$	$V_{GS}=10\text{V}$, $I_D=2.5\text{A}$			1.0	Ω
DYNAMIC PARAMETERS						
Input Capacitance	C_{ISS}	$V_{GS}=0\text{V}$, $V_{DS}=25\text{V}$, $f=1.0\text{MHz}$		550		pF
Output Capacitance	C_{OSS}			68		pF
Reverse Transfer Capacitance	C_{RSS}			38		pF
SWITCHING PARAMETERS						
Total Gate Charge	Q_G	$V_{DS}=50\text{V}$, $V_{GS}=10\text{V}$, $I_D=1.3\text{A}$, $I_G=100\mu\text{A}$ (Note 1, 2)		22		nC
Gate to Source Charge	Q_{GS}			2.6		nC
Gate to Drain Charge	Q_{GD}			2.9		nC
Turn-ON Delay Time	$t_{D(ON)}$	$V_{DD}=30\text{V}$, $V_{GS}=10\text{V}$, $I_D=0.5\text{A}$, $R_G=25\Omega$ (Note 1, 2)		43		ns
Rise Time	t_R			28		ns
Turn-OFF Delay Time	$t_{D(OFF)}$			90		ns
Fall-Time	t_F			25		ns
SOURCE- DRAIN DIODE RATINGS AND CHARACTERISTICS						
Maximum Body-Diode Continuous Current	I_S				5	A
Maximum Body-Diode Pulsed Current	I_{SM}				20	A
Drain-Source Diode Forward Voltage	V_{SD}	$V_{GS}=0\text{V}$, $I_S=5.0\text{A}$			1.4	V
Reverse Recovery Time	t_{rr}	$V_{GS}=0\text{V}$, $I_S=5.0\text{A}$		240		ns
Reverse Recovery Charge	Q_{rr}	$di_F/dt=100\text{A}/\mu\text{s}$ (Note 1)		1.0		μC

Notes: 1. Pulse Test: Pulse width $\leq 300\mu\text{s}$, Duty cycle $\leq 2\%$.

2. Essentially independent of operating temperature.

■ TEST CIRCUITS AND WAVEFORMS

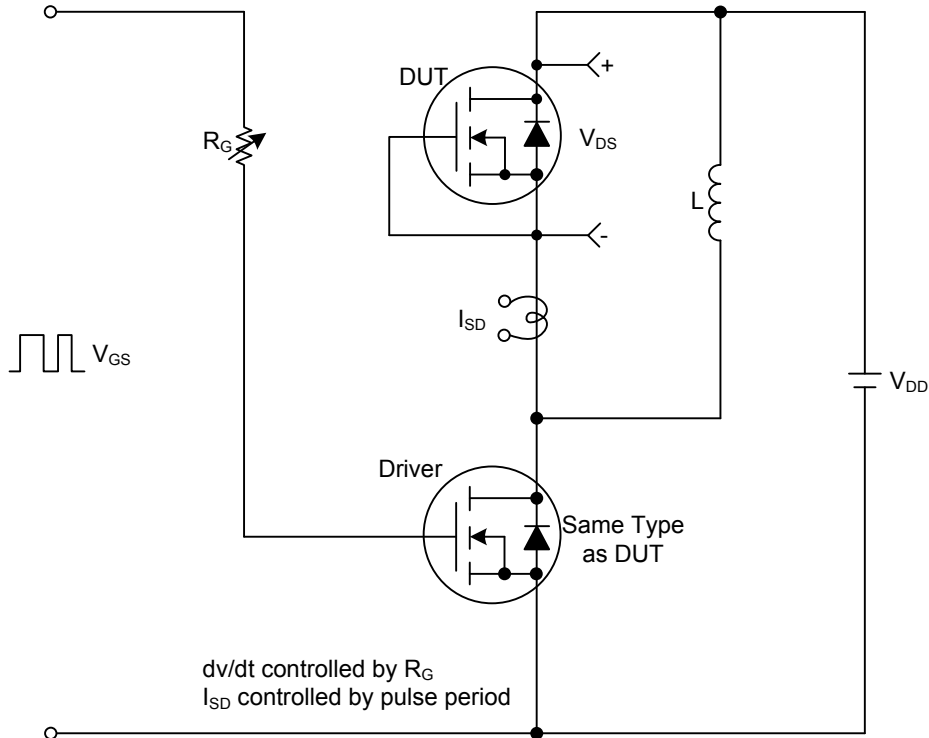

Peak Diode Recovery dv/dt Test Circuit & Waveforms

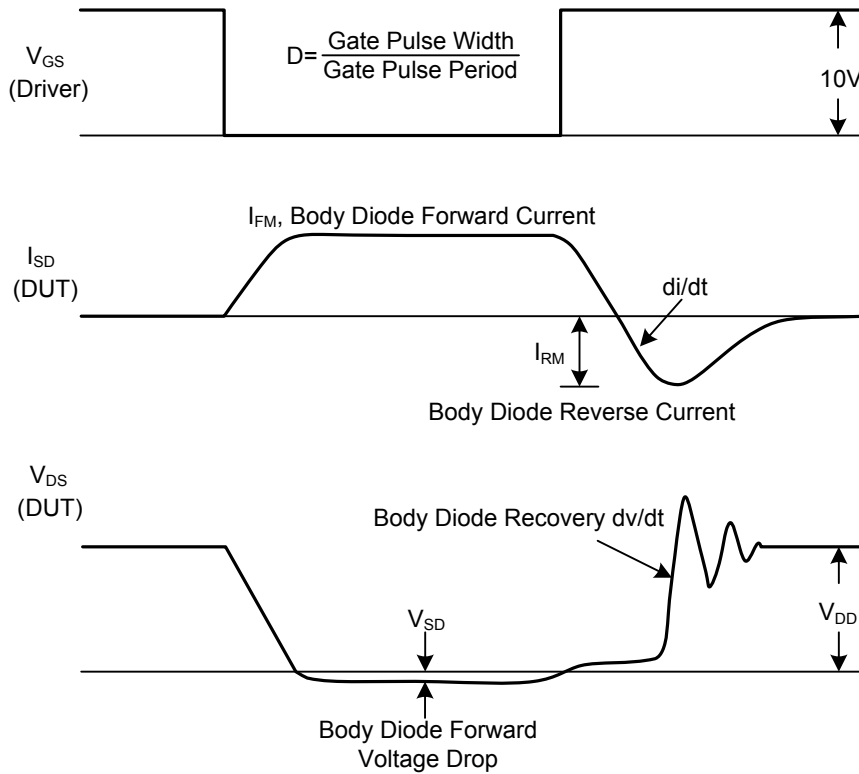

■ TEST CIRCUITS AND WAVEFORMS (Cont.)

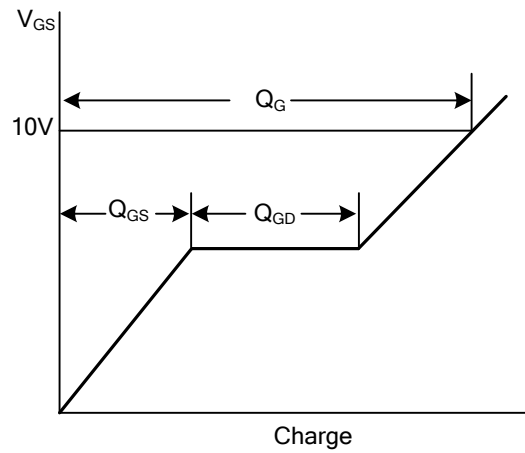
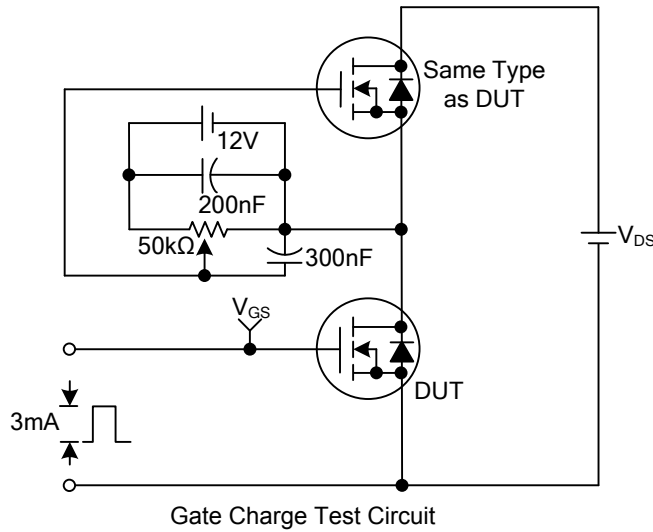

Gate Charge Waveforms

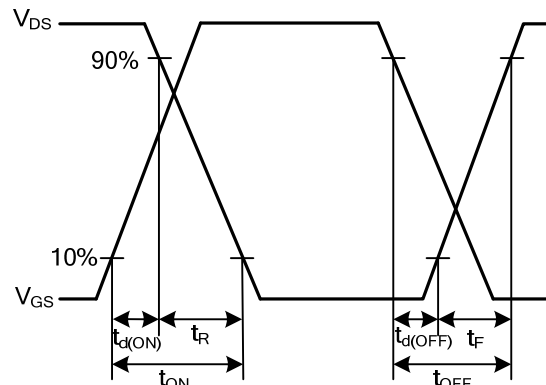
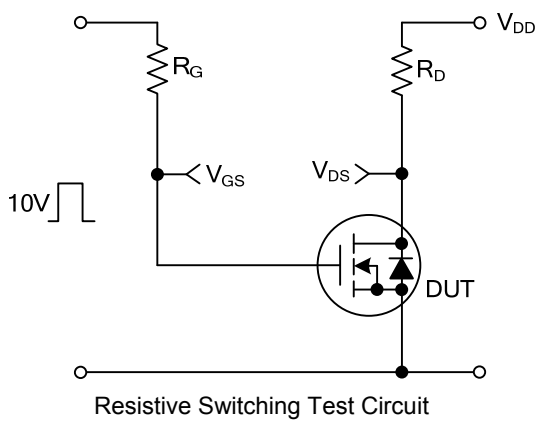

Resistive Switching Waveforms

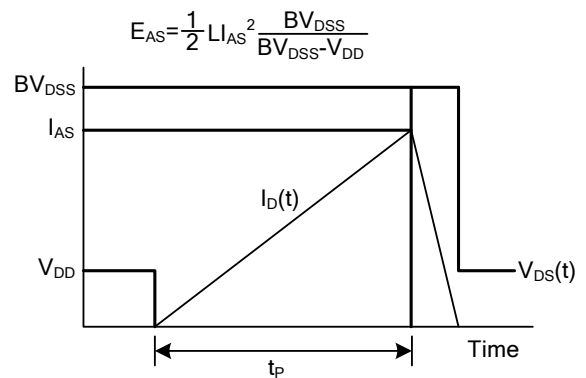
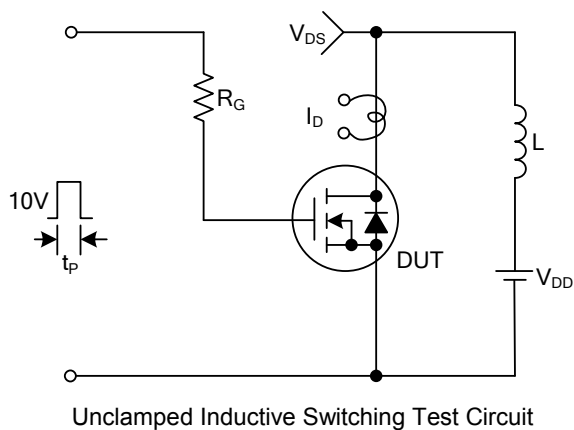

Unclamped Inductive Switching Waveforms

UTC assumes no responsibility for equipment failures that result from using products at values that exceed, even momentarily, rated values (such as maximum ratings, operating condition ranges, or other parameters) listed in products specifications of any and all UTC products described or contained herein. UTC products are not designed for use in life support appliances, devices or systems where malfunction of these products can be reasonably expected to result in personal injury. Reproduction in whole or in part is prohibited without the prior written consent of the copyright owner. The information presented in this document does not form part of any quotation or contract, is believed to be accurate and reliable and may be changed without notice.