



5N65

Power MOSFET

5A, 650V N-CHANNEL POWER MOSFET

■ DESCRIPTION

The UTC **5N65** is a high voltage power MOSFET designed to have better characteristics, such as fast switching time, low gate charge, low on-state resistance and high rugged avalanche characteristics. This power MOSFET is usually used in high speed switching applications at power supplies, PWM motor controls, high efficient DC to DC converters and bridge circuits.

■ FEATURES

- * $R_{DS(ON)} < 2.4\Omega @ V_{GS} = 10V$
- * Ultra Low Gate Charge (Typical 15 nC)
- * Low Reverse Transfer Capacitance ($C_{RSS} = \text{Typical } 6.5 \text{ pF}$)
- * Fast Switching Capability
- * Avalanche Energy Specified
- * Improved dv/dt Capability, High Ruggedness

■ SYMBOL

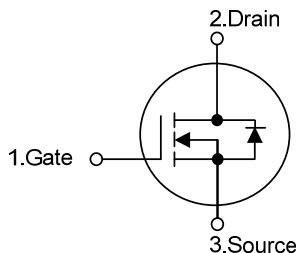

■ ORDERING INFORMATION

Ordering Number		Package	Pin Assignment			Packing
Lead Free	Halogen Free		1	2	3	
5N65L-TA3-T	5N65G-TA3-T	TO-220	G	D	S	Tube
5N65L-TF3-T	5N65G-TF3-T	TO-220F	G	D	S	Tube
5N65L-TF1-T	5N65G-TF1-T	TO-220F1	G	D	S	Tube
5N65L-TF2-T	5N65G-TF2-T	TO-220F2	G	D	S	Tube
5N65L-TF3T-T	5N65G-TF3T-T	TO-220F3	G	D	S	Tube
5N65L-TM3-T	5N65G-TM3-T	TO-251	G	D	S	Tube
5N65L-TN3-R	5N65G-TN3-R	TO-252	G	D	S	Tape Reel

Note: Pin Assignment: G: Gate D: Drain S: Source

<p>5N65L-TA3-T</p> <p>(1)Packing Type (2)Package Type (3)Lead Free</p>	<p>(1) R: Tape Reel, T: Tube (2) TA3: TO-220, TF3: TO-220F, TF1: TO-220F1 TF2: TO-220F2, TF3T: TO-220F3, TM3: TO-251, TN3: TO-252 (3) L: Lead Free, G: Halogen Free</p>
--	---

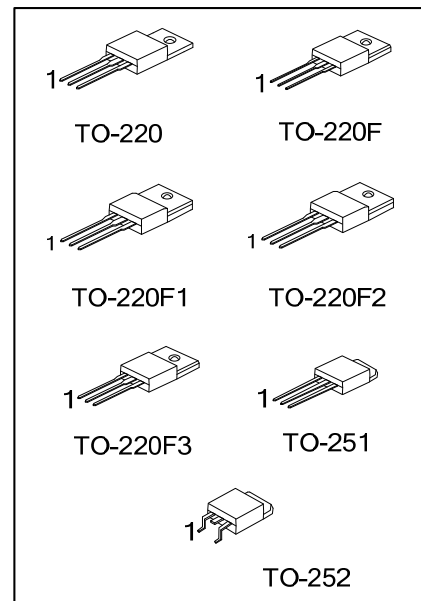

MARKING

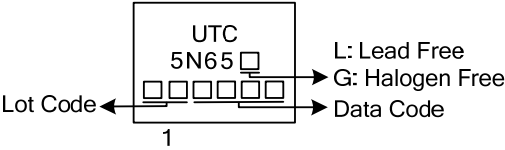

■ ABSOLUTE MAXIMUM RATINGS ($T_C = 25^\circ\text{C}$, unless otherwise specified)

PARAMETER		SYMBOL	RATINGS	UNIT
Drain-Source Voltage		V_{DSS}	650	V
Gate-Source Voltage		V_{GSS}	± 30	V
Avalanche Current (Note 2)		I_{AR}	5	A
Continuous Drain Current		I_D	5	A
Pulsed Drain Current (Note 2)		I_{DM}	20	A
Avalanche Energy	Single Pulsed (Note 3)	E_{AS}	210	mJ
	Repetitive (Note 2)	E_{AR}	10	
Peak Diode Recovery dv/dt (Note 4)		dv/dt	4.5	V/ns
Power Dissipation	TO-220	P_D	100	W
	TO-220F/TO-220F1		36	
	TO-220F2/TO-220F3		54	
	TO-251/TO-252			
Junction Temperature		T_J	+150	$^\circ\text{C}$
Operation Temperature		T_{OPR}	-55 ~ +150	$^\circ\text{C}$
Storage Temperature		T_{STG}	-55 ~ +150	$^\circ\text{C}$

Notes: 1. Absolute maximum ratings are those values beyond which the device could be permanently damaged.

Absolute maximum ratings are stress ratings only and functional device operation is not implied.

2. Pulse width limited by $T_{J(MAX)}$

3. $L = 16.8\text{mH}$, $I_{AS} = 5\text{A}$, $V_{DD} = 50\text{V}$, $R_G = 25\ \Omega$, Starting $T_J = 25^\circ\text{C}$

4. $I_{SD} \leq 5\text{A}$, $di/dt \leq 200\text{A}/\mu\text{s}$, $V_{DD} \leq BV_{DSS}$, Starting $T_J = 25^\circ\text{C}$

■ THERMAL DATA

PARAMETER		SYMBOL	RATINGS	UNIT
Junction to Ambient	TO-220	θ_{JA}	62.5	$^\circ\text{C}/\text{W}$
	TO-220F/TO-220F1		62.5	
	TO-220F2/TO-220F3		160	
	TO-251 / TO-252			
Junction to Case	TO-220	θ_{JC}	1.25	$^\circ\text{C}/\text{W}$
	TO-220F/TO-220F1		3.47	
	TO-220F2/TO-220F3			
	TO-251 / TO-252		2.3	

■ ELECTRICAL CHARACTERISTICS (T_C = 25°C, unless otherwise specified)

PARAMETER	SYMBOL	TEST CONDITIONS	MIN	TYP	MAX	UNIT	
OFF CHARACTERISTICS							
Drain-Source Breakdown Voltage	BV _{DSS}	V _{GS} = 0V, I _D = 250μA	650			V	
Drain-Source Leakage Current	I _{DSS}	V _{DS} = 650V, V _{GS} = 0V			1	μA	
Gate-Source Leakage Current	Forward	I _{GSS}			100	nA	
	Reverse				-100		
Breakdown Voltage Temperature Coefficient	ΔBV _{DSS} /ΔT _J	I _D = 250μA, Referenced to 25°C		0.6		V/°C	
ON CHARACTERISTICS							
Gate Threshold Voltage	V _{GS(TH)}	V _{DS} = V _{GS} , I _D = 250μA	2.0		4.0	V	
Static Drain-Source On-State Resistance	R _{DS(ON)}	V _{GS} = 10V, I _D = 2.5A		2.0	2.4	Ω	
DYNAMIC CHARACTERISTICS							
Input Capacitance	C _{ISS}	V _{DS} = 25V, V _{GS} = 0V, f = 1.0MHz		515	670	pF	
Output Capacitance	C _{OSS}				55	72	pF
Reverse Transfer Capacitance	C _{RSS}				6.5	8.5	pF
SWITCHING CHARACTERISTICS							
Turn-On Delay Time	t _{D(ON)}	V _{DD} = 325V, I _D = 5A, R _G = 25Ω (Note 1, 2)		10	30	ns	
Turn-On Rise Time	t _R			42	90	ns	
Turn-Off Delay Time	t _{D(OFF)}			38	85	ns	
Turn-Off Fall Time	t _F			46	100	ns	
Total Gate Charge	Q _G	V _{DS} = 520 V, I _D = 5A, V _{GS} = 10 V (Note 1, 2)		15	19	nC	
Gate-Source Charge	Q _{GS}			2.5		nC	
Gate-Drain Charge	Q _{GD}			6.6		nC	
DRAIN-SOURCE DIODE CHARACTERISTICS AND MAXIMUM RATINGS							
Drain-Source Diode Forward Voltage	V _{SD}	V _{GS} = 0 V, I _S = 5A			1.4	V	
Maximum Continuous Drain-Source Diode Forward Current	I _S				5	A	
Maximum Pulsed Drain-Source Diode Forward Current	I _{SM}				20	A	
Reverse Recovery Time	t _{rr}	V _{GS} = 0 V, I _S = 5A, dI _F / dt = 100 A/μs (Note 1)		300		ns	
Reverse Recovery Charge	Q _{RR}			2.2		μC	

Notes: 1. Pulse Test: Pulse width ≤ 300μs, Duty cycle ≤ 2%
2. Essentially independent of operating temperature

■ TEST CIRCUITS AND WAVEFORMS

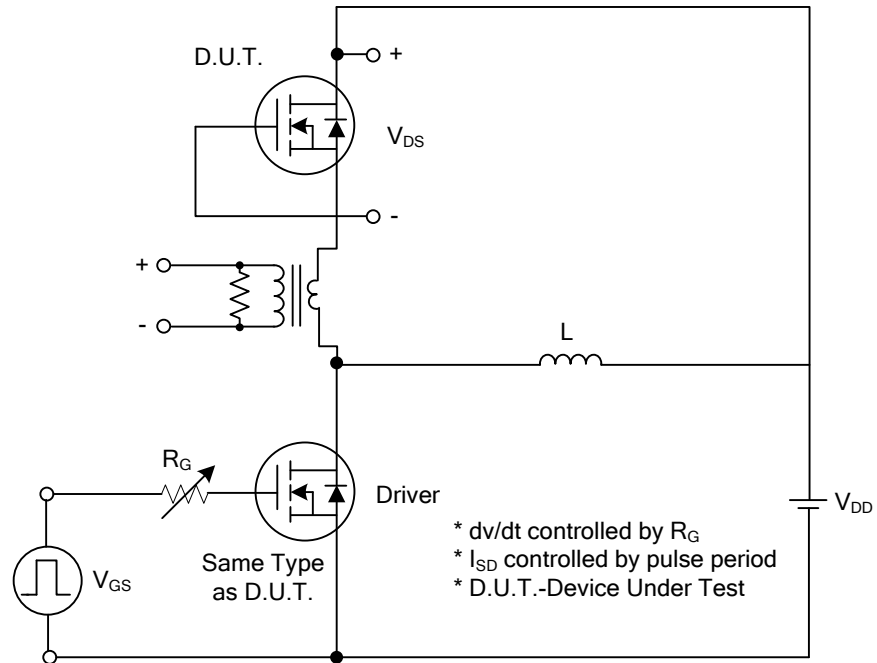

Peak Diode Recovery dv/dt Test Circuit

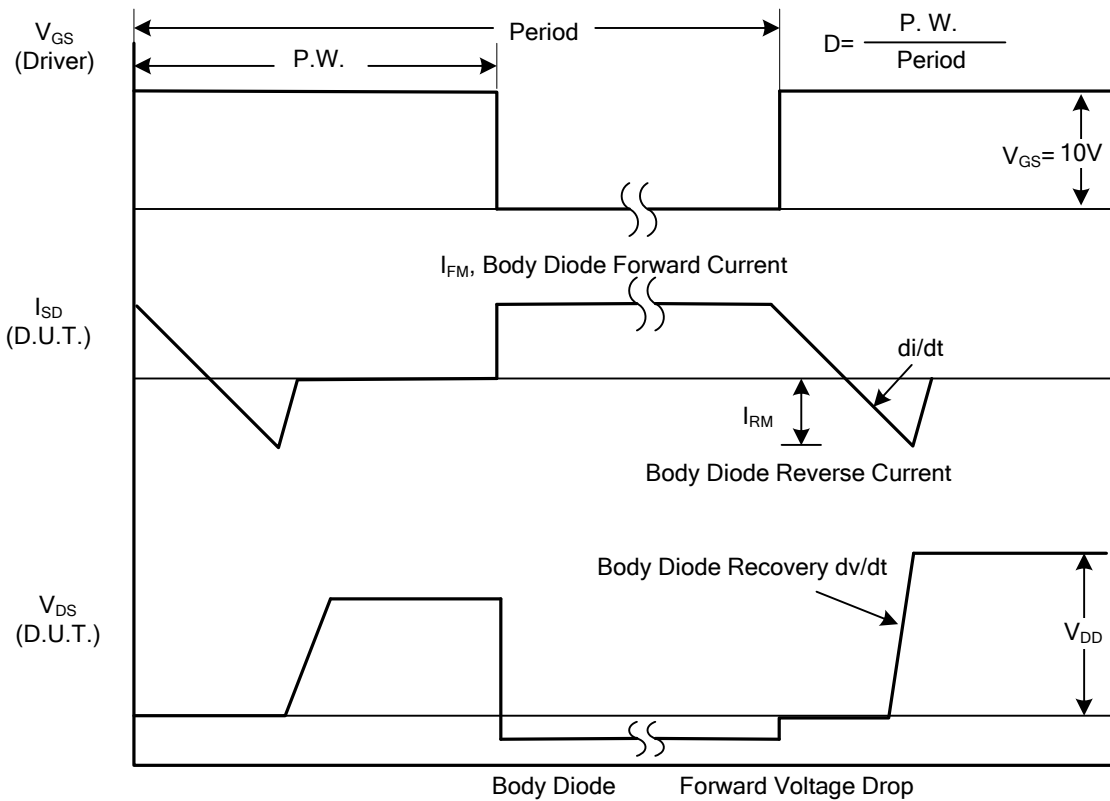

Peak Diode Recovery dv/dt Waveforms

TEST CIRCUITS AND WAVEFORMS (Cont.)

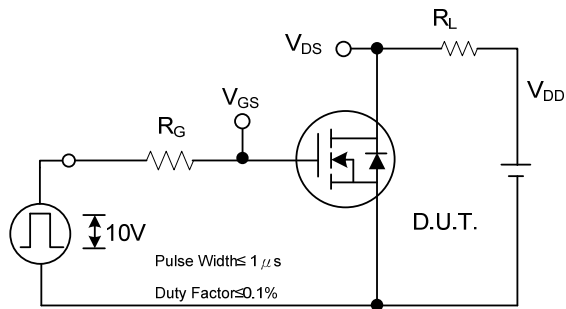

Switching Test Circuit

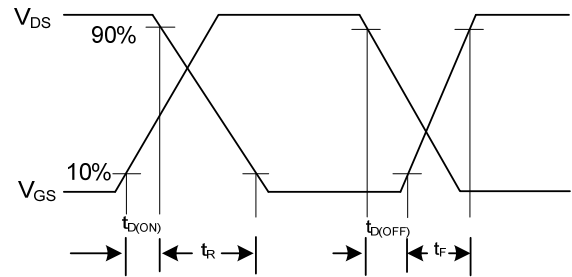

Switching Waveforms

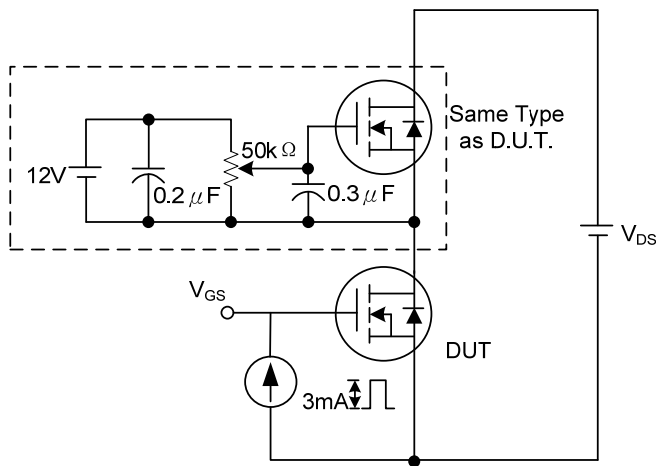

Gate Charge Test Circuit

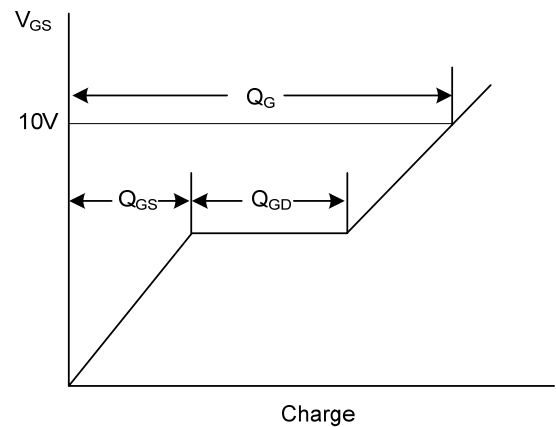

Gate Charge Waveform

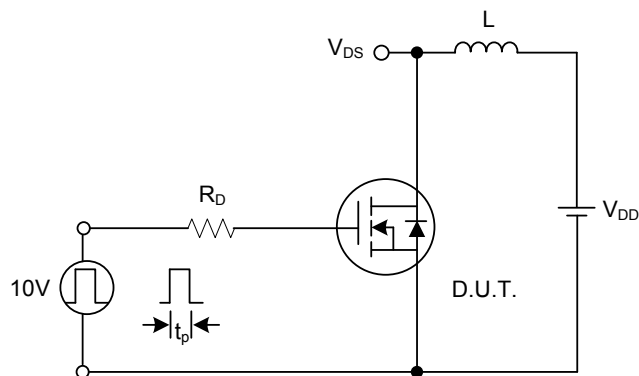

Unclamped Inductive Switching Test Circuit

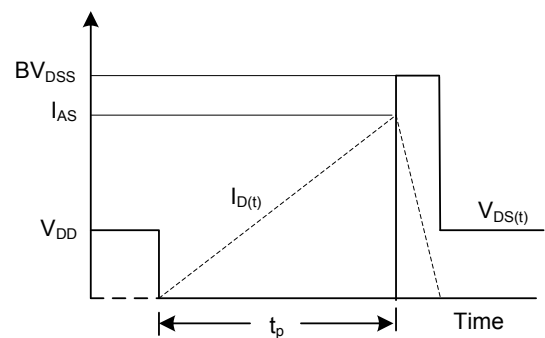

Unclamped Inductive Switching Waveforms

TYPICAL CHARACTERISTICS

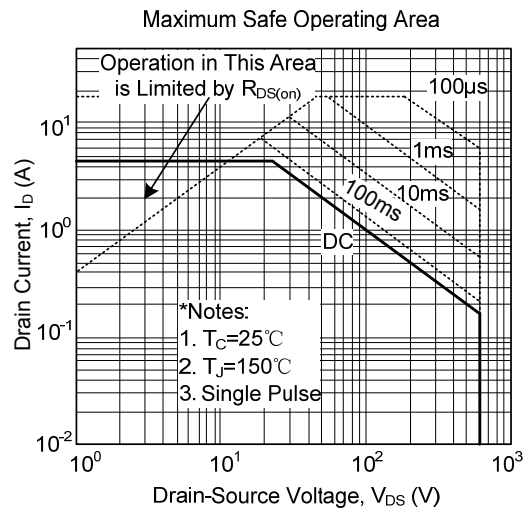
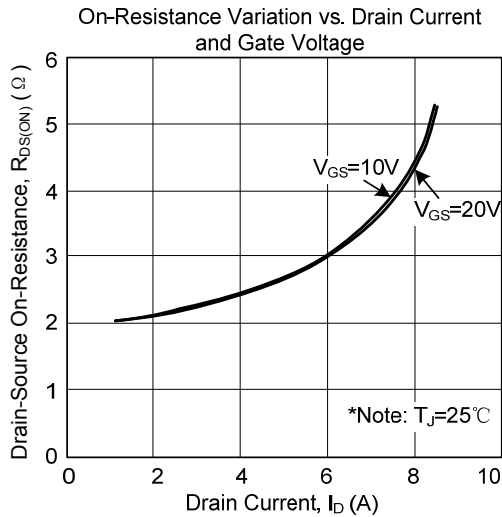
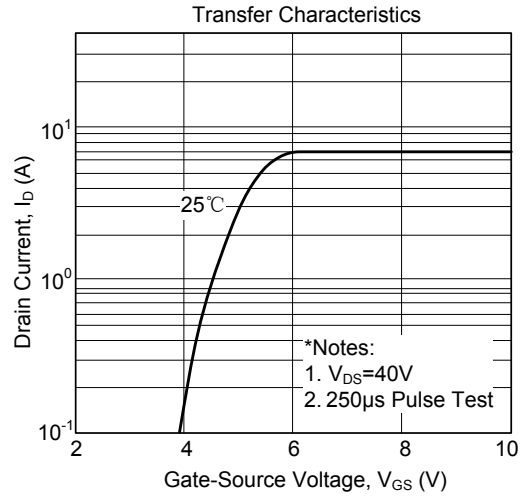
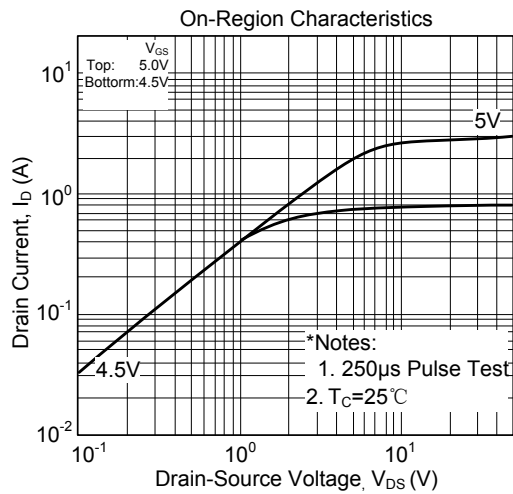

UTC assumes no responsibility for equipment failures that result from using products at values that exceed, even momentarily, rated values (such as maximum ratings, operating condition ranges, or other parameters) listed in products specifications of any and all UTC products described or contained herein. UTC products are not designed for use in life support appliances, devices or systems where malfunction of these products can be reasonably expected to result in personal injury. Reproduction in whole or in part is prohibited without the prior written consent of the copyright owner. The information presented in this document does not form part of any quotation or contract, is believed to be accurate and reliable and may be changed without notice.