

Description

The 5P8390x is a high performance, 1-to-4/6/8 crystal input to LVCMOS fanout buffer with output enable pins. This device accepts a fundamental mode crystal from 10MHz to 40MHz and outputs LVCMOS clocks with best-in-class phase noise performance.

The 5P8390x family (5P83904, 5P83905, and 5P83908) features a synchronous glitch-free Output Enable function to eliminate any intermediate incorrect output clock cycles when enabling or disabling outputs. It comes in standard TSSOP packages or small QFN packages and can operate from 1.8V to 3.3V supplies.

Features

- 4/6/8 copies of LVCMOS output clocks with best-in-class phase noise performance
- Phase Noise:
 - Offset Noise Power (3.3V)
 - 100Hz: -131 dBc/Hz
 - 1KHz: -145 dBc/Hz
 - 10KHz: -154 dBc/Hz
 - 100KHz: -161 dBc/Hz
- Operating power supply modes:
 - Full 3.3V, 2.5V, 1.8V
 - Mixed 3.3V core/2.5V output operating supply
 - Mixed 3.3V core/1.8V output operating supply
 - Mixed 2.5V core/1.8V output operating supply
- Crystal Oscillator Interface
- Synchronous Output Enable
- Packaged in 16-, 20-pin TSSOP and QFN packages (Pb free, fully RoHS compliant)
- Extended (-40°C to +105°C) temperature range

5P83904 Block Diagram

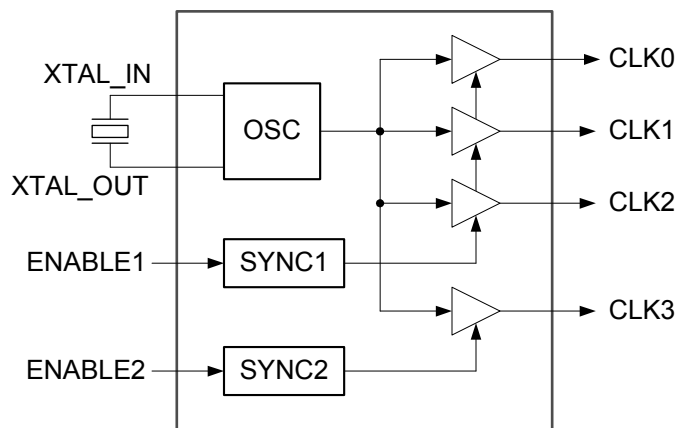

5P83905 Block Diagram

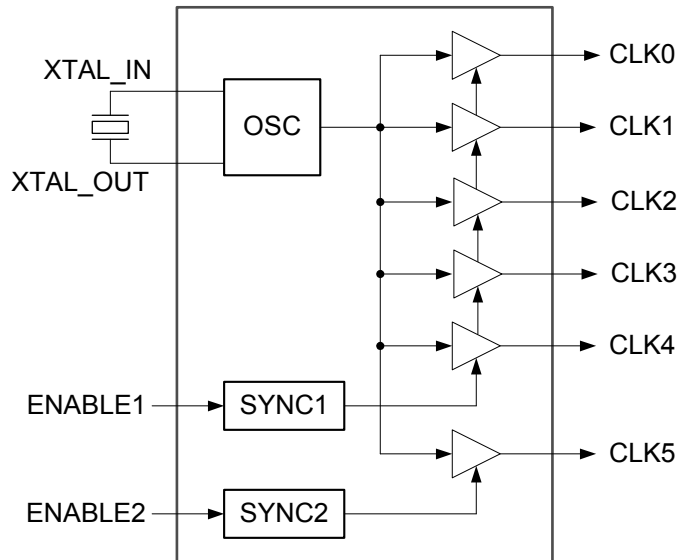

5P83908 Block Diagram

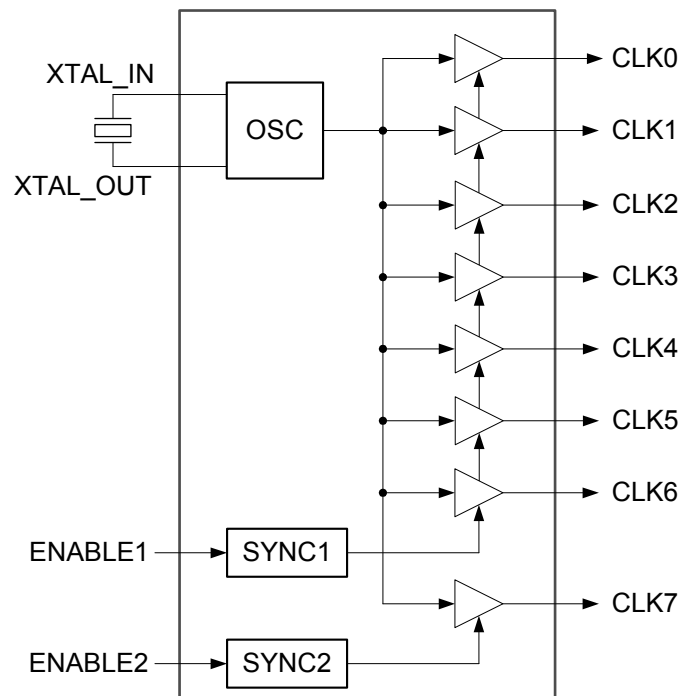

Pin Descriptions

Pin Name	Pin Number			Pin Type	Pin Description
	5P83904	5P83905	5P83908		
XTAL_IN	16	16	20	Input	Oscillator Input from Crystal.
XTAL_OUT	1	1	1	Input	Oscillator Output to drive Crystal.
VDD	9	9	2, 11	Power	Positive power supply for core.
VDDO	5, 13	5, 13	7, 16	Power	Positive power supply for outputs.
GND	3, 7, 11	3, 7, 11	5, 9, 13, 19	Power	Power supply ground.
ENABLE1	15	15	18	Input	Output Enable pin. Please see below Output Enable Function Table. Active High. Internal pull-up.
ENABLE2	2	2	3	Input	Output Enable pin. Please see below Output Enable Function Table. Active High. Internal pull-up.
CLK0	4	4	4	Output	LVC MOS Clock Output 0. Voltage set by VDDO.
CLK1	8	6	6	Output	LVC MOS Clock Output 1. Voltage set by VDDO.
CLK2	12	8	8	Output	LVC MOS Clock Output 2. Voltage set by VDDO.
CLK3	14	10	10	Output	LVC MOS Clock Output 3. Voltage set by VDDO.
CLK4	—	12	12	Output	LVC MOS Clock Output 4. Voltage set by VDDO.
CLK5	—	14	14	Output	LVC MOS Clock Output 5. Voltage set by VDDO.
CLK6	—	—	15	Output	LVC MOS Clock Output 6. Voltage set by VDDO.
CLK7	—	—	17	Output	LVC MOS Clock Output 7. Voltage set by VDDO.
NC	6, 10	—	—	NC	No connect.

Output Enable Function Table

ENABLE1	ENABLE2	5P83904 CLK0-2	5P83905 CLK0-4	5P83908 CLK0-6	5P83904 CLK3	5P83905 CLK5	5P83908 CLK7
0	0	Low	Low	Low	Low	Low	Low
0	1	Low	Low	Low	Active	Active	Active
1	0	Active	Active	Active	Low	Low	Low
1(default)	1(default)	Active	Active	Active	Active	Active	Active

Absolute Maximum Ratings

Stresses above the ratings listed below can cause permanent damage to the 5P8390x. These ratings, which are standard values for IDT commercially rated parts, are stress ratings only. Functional operation of the device at these or any other conditions above those indicated in the operational sections of the specifications is not implied. Exposure to absolute maximum rating conditions for extended periods can affect product reliability. Electrical parameters are guaranteed only over the recommended operating temperature range.

Item	Rating
Supply Voltage, VDD	3.465V
Output Enable and All Outputs	-0.4 V to VDD+0.5 V
CLKIN	-0.4 V to 3.465V
Ambient Operating Temperature (extended)	-40 to +105°C
Storage Temperature	-65 to +150°C
Junction Temperature	125°C
Soldering Temperature	260°C

Recommended Operation Conditions

Parameter	Min.	Typ.	Max.	Units
Ambient Operating Temperature (extended)	-40		+105	°C
Power Supply Voltage (measured in respect to GND)	+1.71		+3.465	V

DC Electrical Characteristics

(VDD = 1.8V, 2.5V, 3.3V)

VDD=1.8V ±5% , Ambient temperature -40° to +105°C, unless stated otherwise

Parameter	Symbol	Conditions	Min.	Typ.	Max.	Units
Input High Voltage	V _{IH}	XTAL_IN, ENABLE1/2 pins	0.7xVDD			V
Input Low Voltage	V _{IL}	XTAL_IN, ENABLE1/2 pins			0.3xVDD	V
Output High Voltage	V _{OH}	I _{OH} = -4 mA	1.65		1.85	V
Output Low Voltage	V _{OL}	I _{OL} = 4 mA	0.03		0.05	V
Nominal Output Impedance	Z _O			14		Ω
Operating Supply Current						
5P83904	IDD	Outputs On, 25MHz with No Load		8.9		mA
5P83905		Outputs On, 25MHz with No Load		9.0		
5P83908		Outputs On, 25MHz with No Load		9.2		

VDD=2.5 V ±5%, Ambient temperature -40° to +105°C, unless stated otherwise

Parameter	Symbol	Conditions	Min.	Typ.	Max.	Units
Input High Voltage	V _{IH}	XTAL_IN, ENABLE1/2 pins	0.7xVDD			V
Input Low Voltage	V _{IL}	XTAL_IN, ENABLE1/2 pins			0.3xVDD	V
Output High Voltage	V _{OH}	I _{OH} = -4 mA	2.31		2.58	V
Output Low Voltage	V _{OL}	I _{OL} = 4 mA	0.03		0.05	V
Nominal Output Impedance	Z _O			14		Ω
Operating Supply Current						
5P83904	IDD	Outputs On, 25MHz with No Load		10.6		mA
5P83905		Outputs On, 25MHz with No Load		10.7		
5P83908		Outputs On, 25MHz with No Load		10.8		

VDD=3.3 V ±5%, Ambient temperature -40° to +105°C, unless stated otherwise

Parameter	Symbol	Conditions	Min.	Typ.	Max.	Units
Input High Voltage, CLKIN	V _{IH}	XTAL_IN, ENABLE1/2 pins	0.7xVDD			V
Input Low Voltage, CLKIN	V _{IL}	XTAL_IN, ENABLE1/2 pins			0.3xVDD	V
Output High Voltage	V _{OH}	I _{OH} = -4 mA	3.09		3.43	V
Output Low Voltage	V _{OL}	I _{OL} = 4 mA	0.03		0.04	V
Nominal Output Impedance	Z _O			14		Ω
Operating Supply Current						
5P83904	IDD	Outputs On, 25MHz with No Load		12.1		mA
5P83905		Outputs On, 25MHz with No Load		12.2		
5P83908		Outputs On, 25MHz with No Load		12.3		

AC Electrical Characteristics

(VDD = 1.8V, 2.5V, 3.3V)

VDD = 1.8V ±5%, Ambient Temperature -40° to +105°C, unless stated otherwise

Parameter	Symbol	Conditions	Min.	Typ.	Max.	Units
Input Frequency	f _{MAX}	Input Frequency Crystal	8		40	MHz
		Input Frequency Clock	DC		200	
Delay for Output Enable / Disable Time ENABLEx to BCLKn	t _{EN} / t _{DIS}				3	cycles
Duty Cycle	t _{DC}		45		55	ns
Output to Output Skew	t _{SKEWO-O}			25	65	ps
Phase Noise	Φ _{noise}	f _{OUT} = 25 MHz 100 Hz off Carrier		-121.1974		dBc/Hz
		f _{OUT} = 25 MHz 1 kHz off Carrier		-132.1742		
		f _{OUT} = 25 MHz 10 kHz off Carrier		-143.8058		
		f _{OUT} = 25 MHz 100 kHz off Carrier		-155.2978		
RMS Phase Jitter	t _{JIT} (Φ)	25MHz carrier, Integration Range: 12kHz-20MHz		0.279		ps
Output Rise/Fall Time	t _R / t _F	20% to 80%			0.95	ns
Device to Device Skew					200	ps
Propagation Delay		freq, LVCMOS INPUT	2.5	3.1	6	ns

VDD = 2.5 V ±5%, Ambient Temperature -40° to +105°C, unless stated otherwise

Parameter	Symbol	Conditions	Min.	Typ.	Max.	Units
Input Frequency	f _{MAX}	Input Frequency Crystal	8		40	MHz
		Input Frequency Clock	DC		200	
Delay for Output Enable / Disable Time ENABLEx to BCLKn	t _{EN} / t _{DIS}				3	cycles
Duty Cycle	t _{DC}		45		55	ns
Output to Output Skew	t _{SKEWO-O}			25	65	ps
Phase Noise	Φ _{noise}	f _{OUT} = 25 MHz 100 Hz off Carrier		-131.26		dBc/Hz
		f _{OUT} = 25 MHz 1 kHz off Carrier		-139.2177		
		f _{OUT} = 25 MHz 10 kHz off Carrier		-149.5185		
		f _{OUT} = 25 MHz 100 kHz off Carrier		-158.7531		
RMS Phase Jitter	t _{JIT} (Φ)	25MHz carrier, Integration Range: 12kHz-20MHz		0.2		ps
Output Rise/Fall Time	t _R / t _F	20% to 80%			0.9	ns
Device to Device Skew					200	ps
Propagation Delay		freq, LVCMOS INPUT	2.5	3.6	6	ns

VDD = 3.3 V ±5%, Ambient Temperature -40° to +105°C, unless stated otherwise

Parameter	Symbol	Conditions	Min.	Typ.	Max.	Units
Input Frequency	f _{MAX}	Input Frequency Crystal	8		40	MHz
		Input Frequency Clock	DC		200	
Delay for Output Enable / Disable Time ENABLEx to BCLKn	t _{EN} / t _{DIS}				3	cycles
Duty Cycle	t _{DC}		45		55	ns
Output to Output Skew	t _{SKEWO-O}			25	65	ps

Parameter	Symbol	Conditions	Min.	Typ.	Max.	Units
Phase Noise	Φ_{noise}	$f_{OUT} = 25$ MHz 100 Hz off Carrier		-131.27		dBc/Hz
		$f_{OUT} = 25$ MHz 1 kHz off Carrier		-145.3267		
		$f_{OUT} = 25$ MHz 10 kHz off Carrier		-154.3789		
		$f_{OUT} = 25$ MHz 100 kHz off Carrier		-161.1555		
RMS Phase Jitter	$t_{JIT}(\Phi)$	25MHz carrier, Integration Range: 12kHz-20MHz		0.16		ps
Output Rise/Fall Time	t_R / t_F	20% to 80%			0.85	ns
Device to Device Skew					200	ps
Propagation Delay		freq, LVCMOS INPUT	2.5	2.9	6	ns

Phase Noise Plots

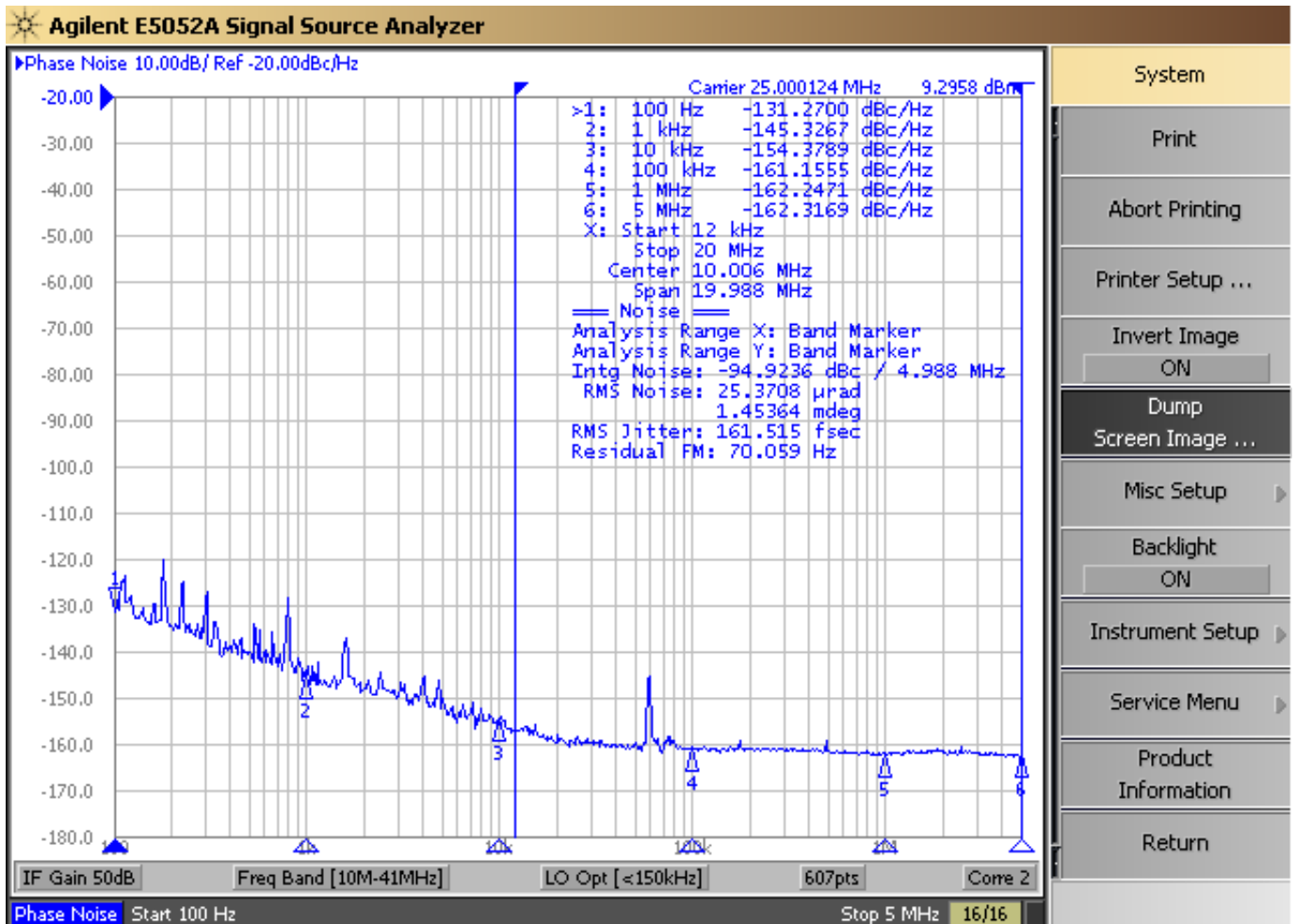

The phase noise plots above show the low Additive Jitter of the 5P8390x high-performance buffer. With an integration range of 12kHz to 20MHz, the reference input has about 58.9fs of RMS phase jitter while the output of 5P8390x has about 70.9fs of RMS phase jitter. This results in a low Additive Phase Jitter of only 39fs.

Test Load and Circuit

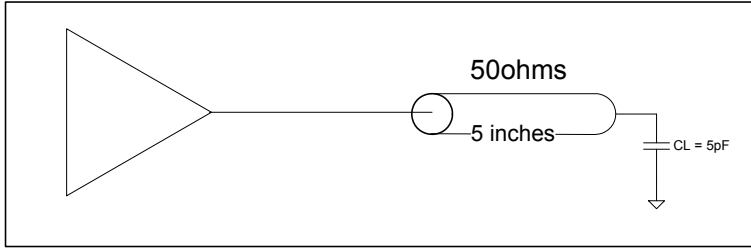

Marking Diagrams

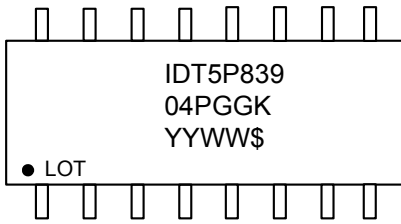

16-pin TSSOP

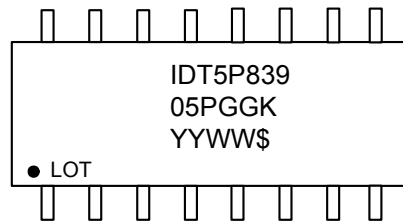

16-pin TSSOP

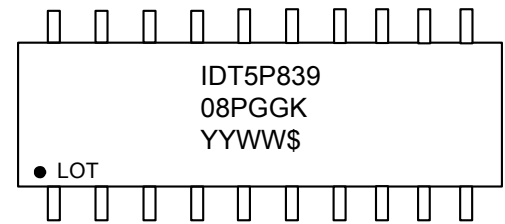

20-pin TSSOP

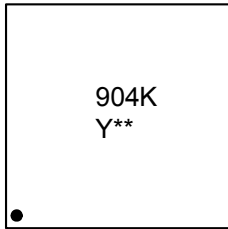

16-pin QFN

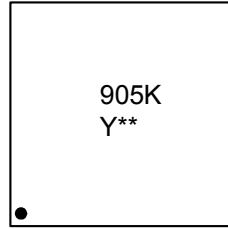

16-pin QFN

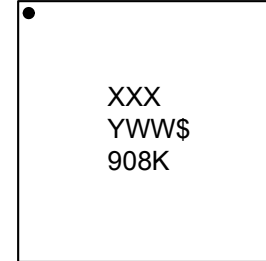

20-pin QFN

Notes:

1. "***" is the lot sequence.
2. "XXX" denotes the last three characters of the Asm lot (20-pin QFN only).
3. "YYWW", "YWW", "YW", or "Y" is the last digit(s) of the year and week that the part was assembled.
4. "\$" denotes the mark code.
5. "LOT" denotes lot number.
6. "G" after the two-letter package code denotes RoHS compliant package.
7. "I" denotes extended temperature range device.
8. Bottom marking: country of origin (TSSOP only).

Package Outline and Package Dimensions (16-pin QFN, 2.5mm x 2.5mm Body, 0.4mm pitch)

REVISIONS			
REV	DESCRIPTION	DATE	APPROVED
00	INITIAL RELEASE	04/03/14	JH
01	ADD PIN1 CHAMFER	12/11/14	JH

TOP VIEW

BOTTOM VIEW

SIDE VIEW

NOTES:

- ALL DIMENSIONING AND TOLERANCING CONFORM TO ANSI Y14.5M-1982
- ALL DIMENSIONS ARE IN MILLIMETERS.

<p>TOLERANCES UNLESS SPECIFIED</p> <p>DECIMAL ±1</p> <p>ANGULAR XX±</p> <p>XX±</p> <p>XX±</p>	<p>APPROVALS</p> <p>DRAWN BY: [Signature]</p> <p>CHECKED: [Signature]</p>	<p>DATE</p> <p>04/03/14</p>
<p>IDT™ 6024 Silver Creek Valley Road San Jose CA 95138 PHONE: (408) 284-8200 WWW.IDT.COM FAX: (408) 284-8591</p>		
<p>TITLE CMG 16 PACKAGE OUTLINE</p> <p>SIZE 2.5 x 2.5 mm BODY</p> <p>DRAWN BY 0.40 mm PITCH VQFN</p>		
<p>DO NOT SCALE DRAWING</p>	<p>DRAWING No. PSC-4478</p>	<p>REV 01</p>
		<p>SHEET 1 OF 2</p>

Package Outline and Package Dimensions, cont. (16-pin QFN, 2.5mm x 2.5mm Body, 0.4mm pitch)

REVISIONS			
REV	DESCRIPTION	DATE	APPROVED
00	INITIAL RELEASE	04/03/14	JH
01	ADD PIN1 CHAMFER	12/11/14	JH

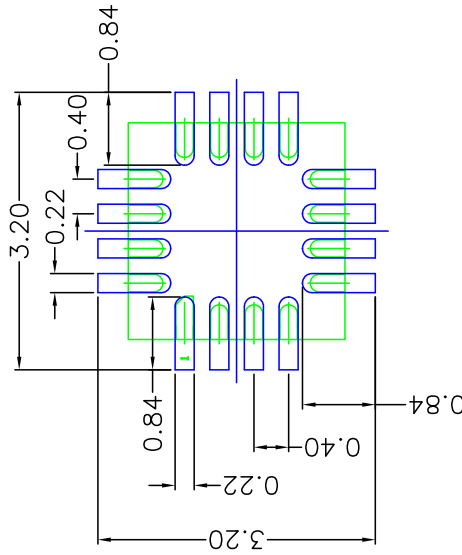

RECOMMENDED LAND PATTERN DIMENSION

NOTES:

1. ALL DIMENSIONS ARE IN MM. ANGLES IN DEGREES.
2. TOP DOWN VIEW AS VIEWED ON PCB.
3. COMPONENT OUTLINE IS SHOWN FOR REFERENCE IN GREEN.
4. LAND PATTERN IN BLUE. NSMD PATTERN ASSUMED.
5. LAND PATTERN RECOMMENDATION PER IPC-7351B GENERIC REQUIREMENT FOR SURFACE MOUNT DESIGN AND LAND PATTERN.

TOLEANCES UNLESS SPECIFIED DECIMAL ±0.10 ANGULAR ±1° XX± XXX±	APPROVALS [Signature]	DATE 04/03/14	IDT 6024 Silver Creek Valley Road San Jose CA 95138 PHONE: (408) 284-8200 FAX: (408) 284-8591 WWW.IDT.COM	TITLE CMG 16 PACKAGE OUTLINE 2.5 x 2.5 mm BODY 0.40 mm PITCH VQFN	SIZE C	DRAWING No. PSC-4478	REV 01
	DO NOT SCALE DRAWING						

Package Outline and Package Dimensions (20-pin QFN, 3mm x 3mm Body, 0.4mm pitch)

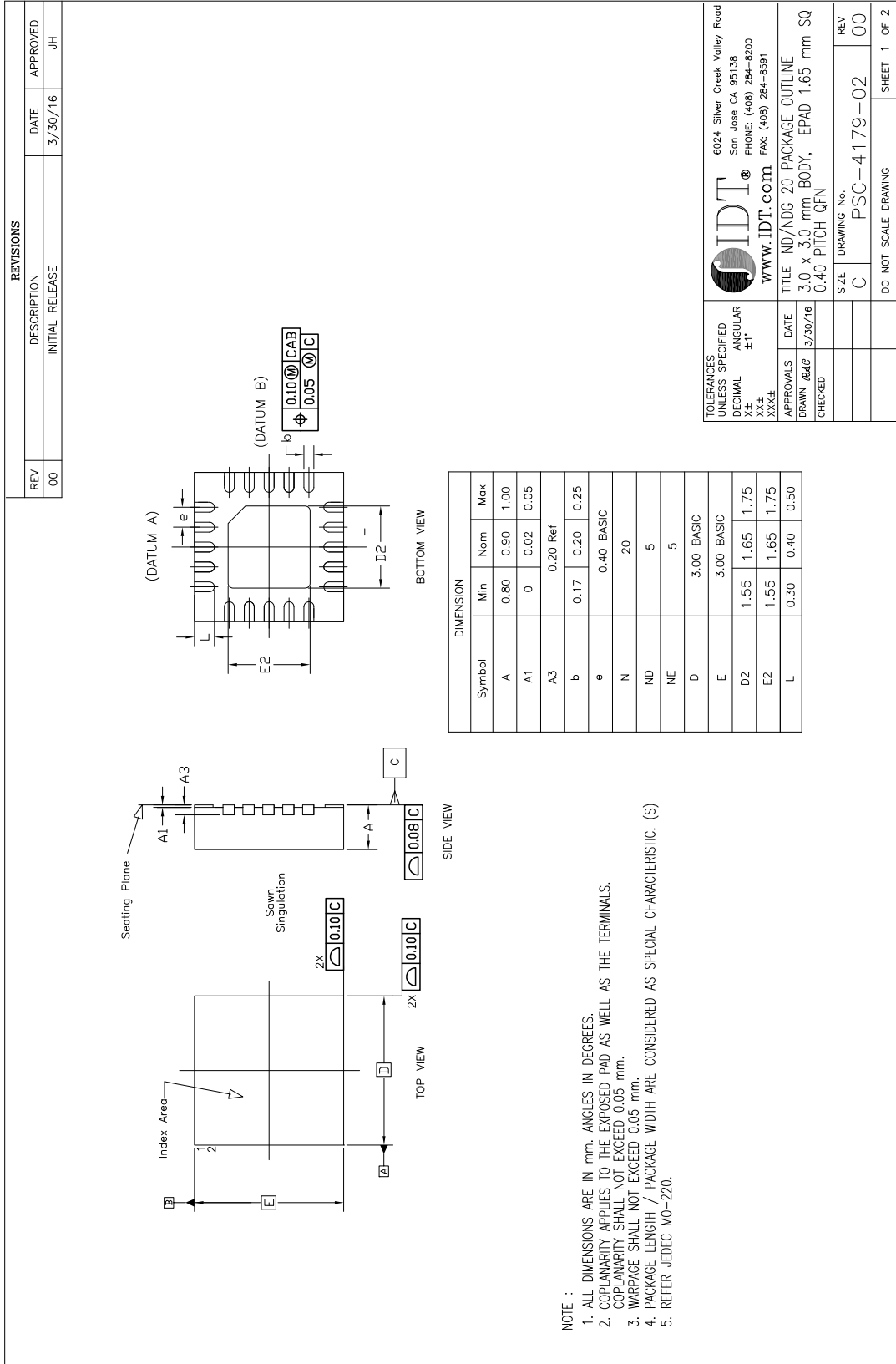

<p>TOLERANCES UNLESS SPECIFIED</p> <p>DECIMAL ±1'</p> <p>X±</p> <p>XX±</p> <p>XXX±</p>	<p>APPROVALS</p> <p>DRAWN & AC</p> <p>CHECKED</p>	<p>DATE</p> <p>3/30/16</p>
<p>6024 Silver Creek Valley Road San Jose CA 95138 PHONE: (408) 284-8200 FAX: (408) 284-8591 WWW.IDT.COM</p>		
<p>TITLE ND/NDG 20 PACKAGE OUTLINE</p> <p>3.0 x 3.0 mm BODY, EPAD 1.65 mm SQ</p> <p>0.40 PITCH QFN</p>		
<p>SIZE C</p> <p>DRAWING No. PSC-4179-02</p>		<p>REV 00</p>
<p>DO NOT SCALE DRAWING</p>		<p>SHEET 1 OF 2</p>

Package Outline and Package Dimensions, cont. (20-pin QFN, 3mm x 3mm Body, 0.4mm pitch)

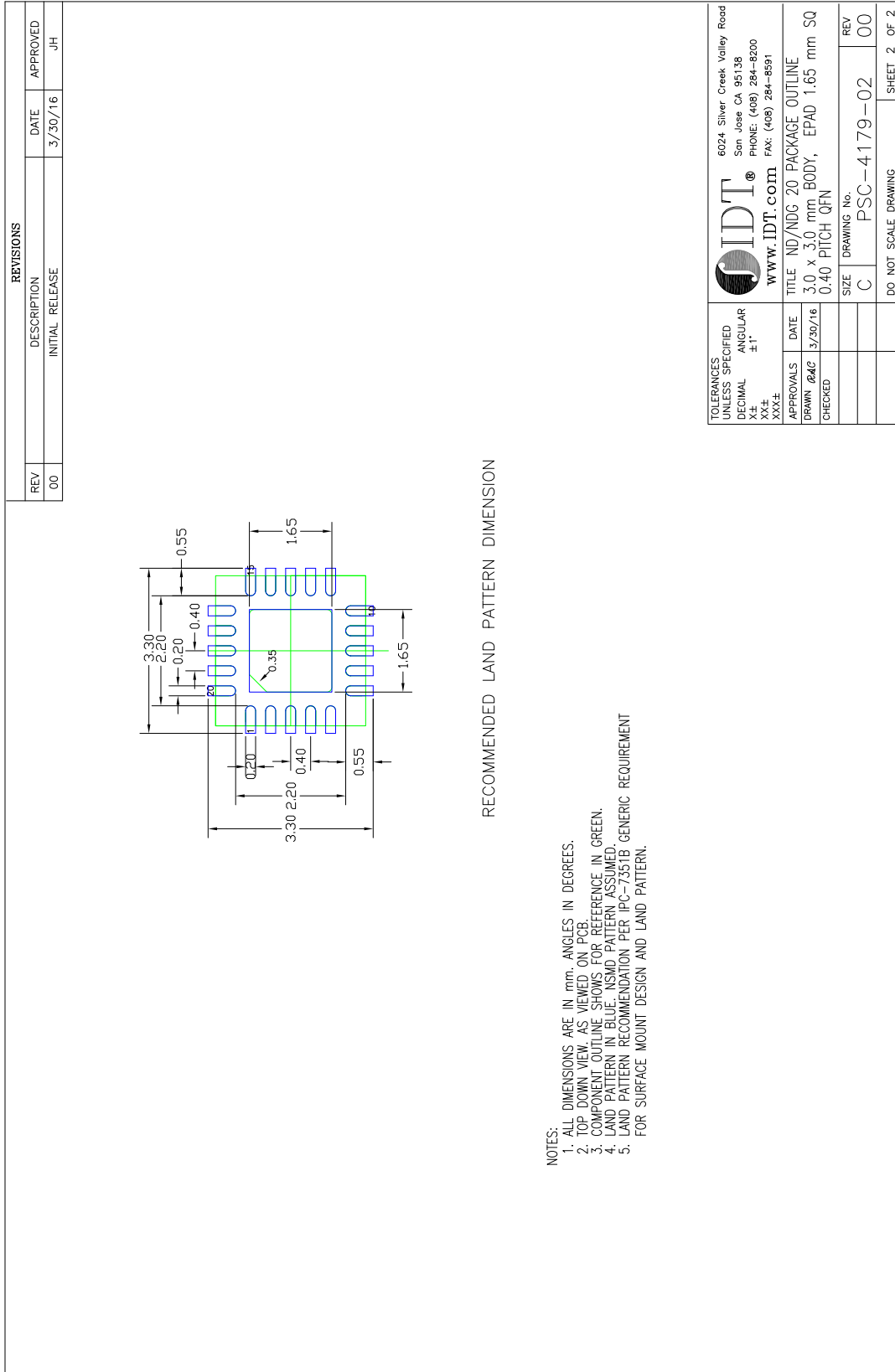

Package Outline and Package Dimensions, cont. (8-, 14-, 16-, 20-pin TSSOP)

REV		DESCRIPTION		DATE		APPROVED	
02		ADD 14 & 16 LD		08/25/98		T. VU	
03		ADD 8 LD		07/10/99		T. VU	
04		ADDED TOPMARK TO TITLE		5/23/01			
05		ADD "GREEN" PGG NOMENCLATURE		10/14/04		TU VU	
06		ADDED PACKAGE CODE		3/8/13		RAC	
07		ADD TOLERANCE FOR A, A1, E AND b		9/3/14		CK LEE	

S Y M B O L	JEDEC VARIATION			N D T E		
	MIN	NOM	MAX	MIN	NOM	MAX
A	.85	1.10	1.20	.85	1.10	1.20
A1	.05	.10	.15	.05	.10	.15
A2	.80	1.00	1.05	.80	1.00	1.05
D	2.90	3.00	3.10	4.5	4.90	5.00
E	6.20	6.40	6.60	3	6.20	6.40
E1	4.30	4.40	4.50	4.6	4.30	4.40
e	.65 BSC			.65 BSC		
b	.19	.25	.30	.19	.25	.30
b1	.19	.22	.25	.19	.22	.25
aaa	-	-	.10	-	-	.10
bbb	-	-	.10	-	-	.10
N	8			14		

PC/PG68			PC/PG614			PC/PG616			PC/PG620			PC/PG624			PC/PG628		
JEDEC VARIATION			JEDEC VARIATION			JEDEC VARIATION			JEDEC VARIATION			JEDEC VARIATION			JEDEC VARIATION		
AA	AB-1	AC	AD	AE	AB	AC	AD	AE	AB	AC	AD	AE	AB	AC	AD	AE	
MIN	NOM	MAX	MIN	NOM	MAX	MIN	NOM	MAX	MIN	NOM	MAX	MIN	NOM	MAX	MIN	NOM	MAX
.85	1.10	1.20	.85	1.10	1.20	.85	1.10	1.20	.85	1.10	1.20	.85	1.10	1.20	.85	1.10	1.20
.05	.10	.15	.05	.10	.15	.05	.10	.15	.05	.10	.15	.05	.10	.15	.05	.10	.15
.80	1.00	1.05	.80	1.00	1.05	.80	1.00	1.05	.80	1.00	1.05	.80	1.00	1.05	.80	1.00	1.05
4.5	4.90	5.00	4.5	4.90	5.00	4.5	4.90	5.00	4.5	4.90	5.00	4.5	4.90	5.00	4.5	4.90	5.00
3	6.20	6.40	3	6.20	6.40	3	6.20	6.40	3	6.20	6.40	3	6.20	6.40	3	6.20	6.40
4.6	4.30	4.40	4.6	4.30	4.40	4.6	4.30	4.40	4.6	4.30	4.40	4.6	4.30	4.40	4.6	4.30	4.40
.65 BSC			.65 BSC			.65 BSC			.65 BSC			.65 BSC			.65 BSC		
.19	.25	.30	.19	.25	.30	.19	.25	.30	.19	.25	.30	.19	.25	.30	.19	.25	.30
.19	.22	.25	.19	.22	.25	.19	.22	.25	.19	.22	.25	.19	.22	.25	.19	.22	.25
-	-	.10	-	-	.10	-	-	.10	-	-	.10	-	-	.10	-	-	.10
-	-	.10	-	-	.10	-	-	.10	-	-	.10	-	-	.10	-	-	.10
8			14			16			20			24			28		

NOTES:

- ALL DIMENSIONING AND TOLERANCING CONFORM TO ASME Y14.5M-1994
- DATUMS **-A-** AND **-B-** TO BE DETERMINED AT DATUM PLANE **-H-**
- DIMENSION E TO BE DETERMINED AT SEATING PLANE **-C-**
- DIMENSIONS D AND E1 ARE TO BE DETERMINED AT DATUM PLANE **-H-**
- DIMENSION D DOES NOT INCLUDE MOLD FLASH, PROTRUSIONS OR GATE BURRS. MOLD FLASH, PROTRUSIONS OR GATE BURRS SHALL NOT EXCEED .15 mm PER SIDE
- DIMENSION E1 DOES NOT INCLUDE INTERLEAD FLASH OR PROTRUSIONS. INTERLEAD FLASH OR PROTRUSIONS SHALL NOT EXCEED .25 mm PER SIDE
- DETAIL OF PIN 1 IDENTIFIER IS OPTIONAL BUT MUST BE LOCATED WITHIN THE ZONE INDICATED
- LEAD WIDTH DIMENSION DOES NOT INCLUDE DAMBAR PROTRUSION. ALLOWABLE DAMBAR PROTRUSION IS .08 mm IN EXCESS OF THE LEAD WIDTH DIMENSION AT MAXIMUM MATERIAL CONDITION. DAMBAR CANNOT BE LOCATED ON THE LOWER RADIUS OR THE FOOT
- THESE DIMENSIONS APPLY TO THE FLAT SECTION OF THE LEAD BETWEEN .10 AND .25 mm FROM THE LEAD TIP
- ALL DIMENSIONS ARE IN MILLIMETERS
- THIS OUTLINE CONFORMS TO JEDEC PUBLICATION 95 REGISTRATION MO-153, VARIATION AA, AB-1, AB, AC, AD & AE

TOLERANCES UNLESS SPECIFIED		IDT 2975 Slender Way	
DECIMAL	ANGULAR	Santa Clara, CA 95054	
XX±	±	PHONE: (408) 727-8116	
XXXX		WWW.IDT.COM	
APPROVALS	DATE	TITLE	
DRAWN JTY	01/19/96	PG/PGG PACKAGE OUTLINE	
CHECKED		(PG OR PA TOPMARK CODE)	
		4.4 mm BODY WIDTH TSSOP .65 mm PITCH	
		SIZE	DRAWING No.
		C	PSC-4056
		REV	07
		DO NOT SCALE DRAWING	
		SHEET 2 OF 3	

Package Outline and Package Dimensions, cont. (8-, 14-, 16-, 20-pin TSSOP)

REVISIONS			
REV	DESCRIPTION	DATE	APPROVED
02	ADD 14- & 16 LD	08/25/98	T. VU
03	ADD 8 LD	07/10/99	T. VU
04	ADDED TOPMARK TO TITLE	5/23/01	
05	ADD "GREEN" PGG NOMENCLATURE	10/14/04	TU VU
06	ADDED PACKAGE CODE	3/8/13	RAC
07	ADD TOLERANCE FOR A, A1, E AND b	9/23/14	CK LEE

LAND PATTERN DIMENSIONS

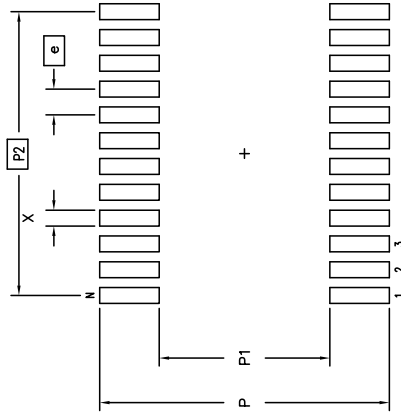

	MIN	MAX	MIN	MAX	MIN	MAX	MIN	MAX	MIN	MAX	MIN	MAX
P	7.20	7.40	7.20	7.40	7.20	7.40	7.20	7.40	7.20	7.40	7.20	7.40
P1	4.20	4.40	4.20	4.40	4.20	4.40	4.20	4.40	4.20	4.40	4.20	4.40
P2	1.95	BSC	3.90	BSC	4.55	BSC	5.85	BSC	7.15	BSC	8.45	BSC
X	.30	.50	.30	.50	.30	.50	.30	.50	.30	.50	.30	.50
e	.65	BSC	.65	BSC	.65	BSC	.65	BSC	.65	BSC	.65	BSC
N	8		14		16		20		24		28	

2975 Stender Way Santa Clara, CA 95054 PHONE: (408) 727-6116 FAX: (408) 492-8674 WWW.IDT.COM		TITLE PGG/PGG PACKAGE OUTLINE (PG OR PA TOPMARK CODE) 4.4 mm BODY WIDTH TSSOP .65 mm PITCH SIZE DRAWING No. PSC-4056 REV 07	
TOLERANCES UNLESS SPECIFIED ANGULAR ± DECIMAL XXX. XXXX. XXXX.		APPROVALS DATE DESIGN BY 01/15/98 CHECKED	
DO NOT SCALE DRAWING		SHEET 3 OF 3	

Ordering Information

Part / Order Number	Marking	Shipping Packaging	Package	Temperature
5P83904PGGK	see page 9	Tubes	16-pin TSSOP	-40° to +105°C
5P83904PGGK8		Tape and Reel	16-pin TSSOP	-40° to +105°C
5P83904CMGK		Cut Tape	16-pin QFN	-40° to +105°C
5P83904CMGK8		Tape and Reel	16-pin QFN	-40° to +105°C
5P83905PGGK		Tubes	16-pin TSSOP	-40° to +105°C
5P83905PGGK8		Tape and Reel	16-pin TSSOP	-40° to +105°C
5P83905CMGK		Cut Tape	16-pin QFN	-40° to +105°C
5P83905CMGK8		Tape and Reel	16-pin QFN	-40° to +105°C
5P83908PGGK		Tubes	20-pin TSSOP	-40° to +105°C
5P83908PGGK8		Tape and Reel	20-pin TSSOP	-40° to +105°C
5P83908NDGK		Tubes	20-pin QFN	-40° to +105°C
5P83908NDGK8		Tape and Reel	20-pin QFN	-40° to +105°C

“G” after the two-letter package code denotes Pb-Free configuration, RoHS compliant.

“K” denotes extended temperature range.

Revision History

Rev.	Date	Originator	Description of Change
A	07/11/16	H.G.	Release to final.
B	10/05/16	Y.G.	1. Update "Propagation Delay" typical values per latest characterization data. 2. Update "Output Rise/Fall" maximum values per latest characterization data.



Corporate Headquarters
6024 Silver Creek Valley Road
San Jose, CA 95138 USA
www.IDT.com

Sales
1-800-345-7015 or 408-284-8200
Fax: 408-284-2775
www.IDT.com/go/sales

Tech Support
www.idt.com/go/support

DISCLAIMER Integrated Device Technology, Inc. (IDT) and its subsidiaries reserve the right to modify the products and/or specifications described herein at any time and at IDT's sole discretion. All information in this document, including descriptions of product features and performance, is subject to change without notice. Performance specifications and the operating parameters of the described products are determined in the independent state and are not guaranteed to perform the same way when installed in customer products. The information contained herein is provided without representation or warranty of any kind, whether express or implied, including, but not limited to, the suitability of IDT's products for any particular purpose, an implied warranty of merchantability, or non-infringement of the intellectual property rights of others. This document is presented only as a guide and does not convey any license under intellectual property rights of IDT or any third parties.

IDT's products are not intended for use in applications involving extreme environmental conditions or in life support systems or similar devices where the failure or malfunction of an IDT product can be reasonably expected to significantly affect the health or safety of users. Anyone using an IDT product in such a manner does so at their own risk, absent an express, written agreement by IDT.

Integrated Device Technology, IDT and the IDT logo are registered trademarks of IDT. Product specification subject to change without notice. Other trademarks and service marks used herein, including protected names, logos and designs, are the property of IDT or their respective third party owners.

Copyright ©2016 Integrated Device Technology, Inc.. All rights reserved.