

$V_{RRM}$	=	200 V
$I_{FAVM}$	=	11000 A
$I_{FRMS}$	=	17300 A
$I_{FSM}$	=	85000 A
$V_{F0}$	=	0.75 V
$r_F$	=	0.020 mW

## Rectifier Diode

# 5SDD 0120C0200

Doc. No. 5SYA1157-01 July 06

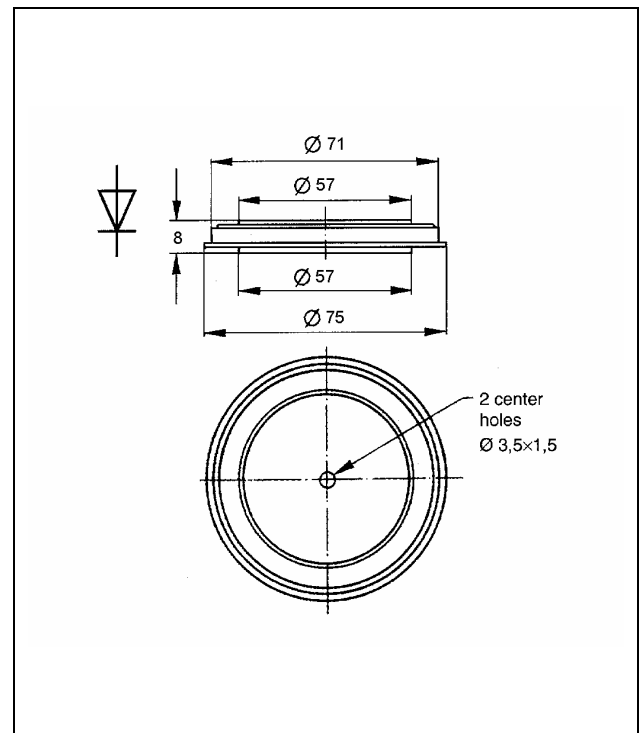
- Optimized for high current rectifiers
- Very low on-state voltage
- Very low thermal resistance

### Blocking

$V_{RRM}$	Repetitive peak reverse voltage	200 V	Half sine wave, $t_P = 10$ ms, $f = 50$ Hz
$V_{RSM}$	Maximum peak reverse voltage	300 V	Half sine wave, $t_P = 10$ ms
$I_{RRM}$	Repetitive peak reverse current	$\leq 50$ mA	$T_j = 170$ °C $V_R = V_{RRM}$

### Mechanical

$F_M$	Mounting force	min.	35 kN
		max.	40 kN
a	Acceleration:	Device unclamped	50 m/s <sup>2</sup>
		Device clamped	200 m/s <sup>2</sup>
m	Weight		0.22 kg
$D_S$	Surface creepage distance		4 mm
$D_a$	Air strike distance		4 mm



**Fig. 1**

Outline drawing.

All dimensions are in millimeters and represent nominal values unless stated otherwise.

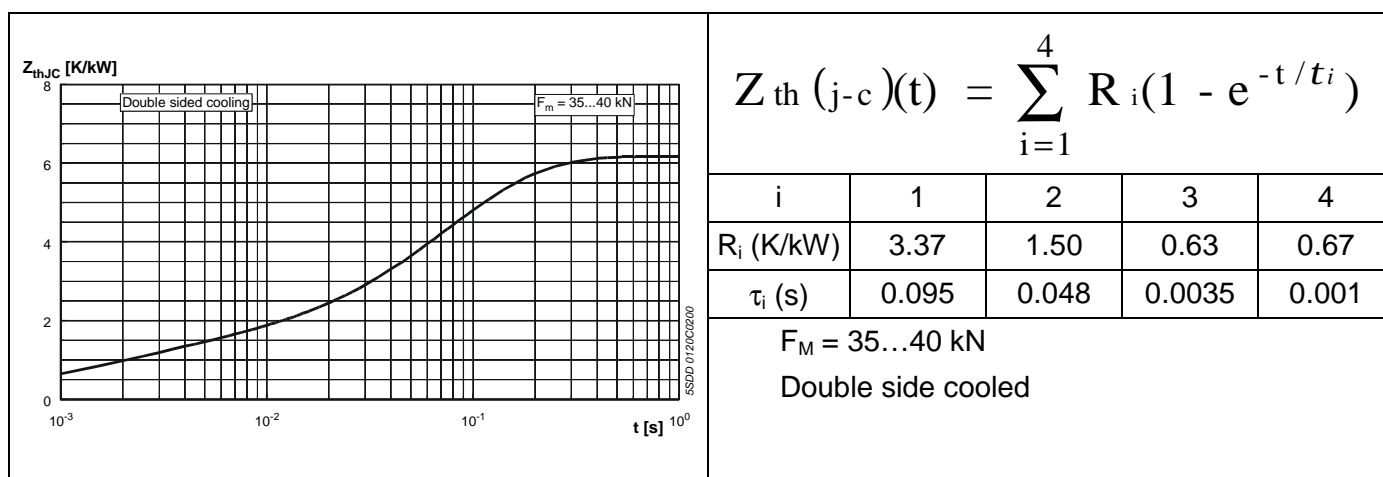
ABB Switzerland Ltd, Semiconductors reserves the right to change specifications without notice.

## On-state

$I_{FAVM}$	Max. average on-state current	11000 A	Half sine wave, $T_c = 85\text{ °C}$	
$I_{FRMS}$	Max. RMS on-state current	17300 A		
$I_{FSM}$	Max. peak non-repetitive surge current	85000 A	$t_p = 10\text{ ms}$	Before surge
		92500 A	$t_p = 8.3\text{ ms}$	$T_j = 170\text{ °C}$
$\int i^2 dt$	Max. surge current integral	36100 $\text{kA}^2\text{s}$	$t_p = 10\text{ ms}$	After surge: $V_R \approx 0\text{V}$
		35700 $\text{kA}^2\text{s}$	$t_p = 8.3\text{ ms}$	
$V_{F\text{ max}}$	Maximum on-state voltage	$\leq 0.92\text{ V}$	$I_F = 8000\text{ A}$	$T_j = 170\text{ °C}$
$V_{F0}$	Threshold voltage	0.75 V	Approximation for	$T_j = 170\text{ °C}$
$r_F$	Slope resistance	0.020 $\text{m}\Omega$	$I_F = 8 - 18\text{ kA}$	

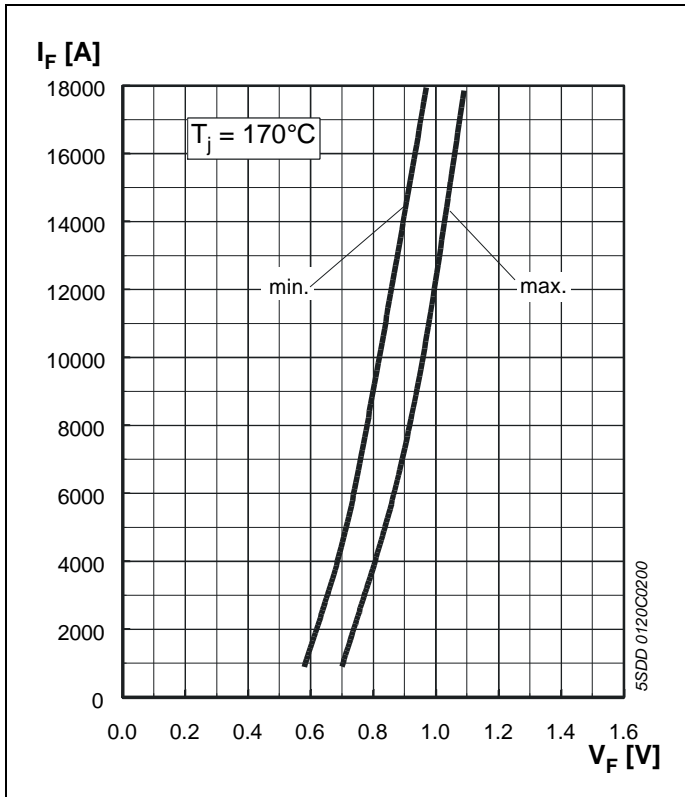
## Thermal characteristics

$T_j$	Operating junction temperature range	-40...170 °C		
$T_{stg}$	Storage temperature range	-40...170 °C		
$R_{th(j-c)}$	Thermal resistance junction to case	$\leq 12\text{ K/kW}$	Anode side cooled	$F_M = 35...40\text{ kN}$
		$\leq 12\text{ K/kW}$	Cathode side cooled	
		$\leq 6\text{ K/kW}$	Double side cooled	
$R_{th(c-h)}$	Thermal resistance case to heatsink	$\leq 6\text{ K/kW}$	Single side cooled	
		$\leq 3\text{ K/kW}$	Double side cooled	



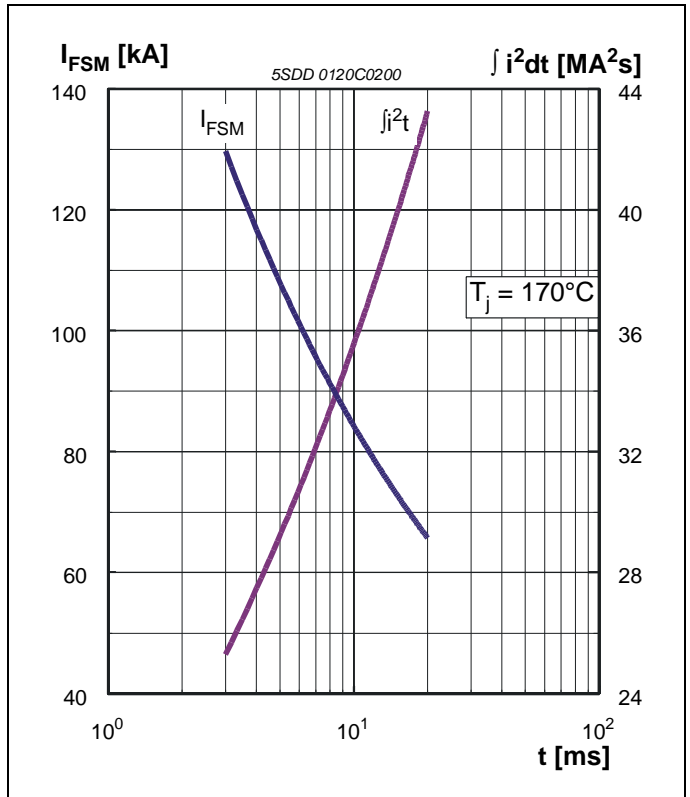
**Fig. 2** Transient thermal impedance (junction-to-case) vs. time in analytical and graphical forms.

### On-state characteristics



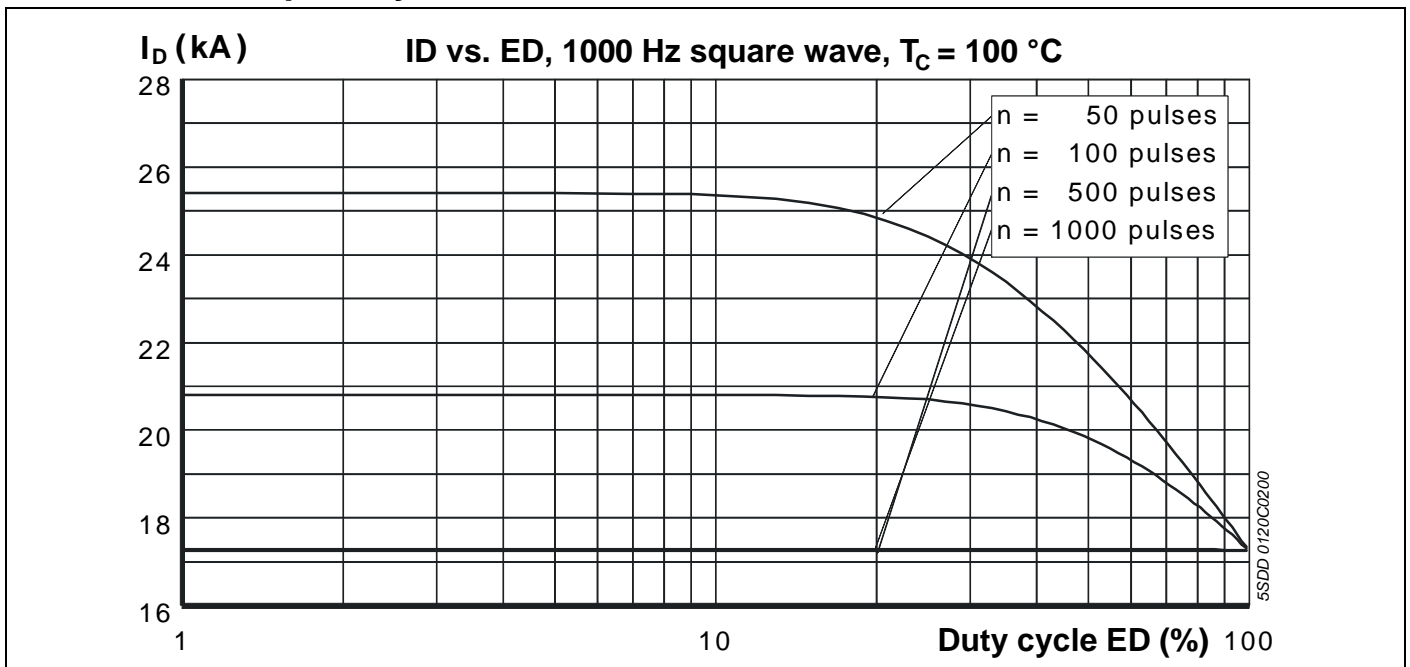
**Fig. 3** Forward current vs. forward voltage (min. and max. values).

### Surge current characteristics



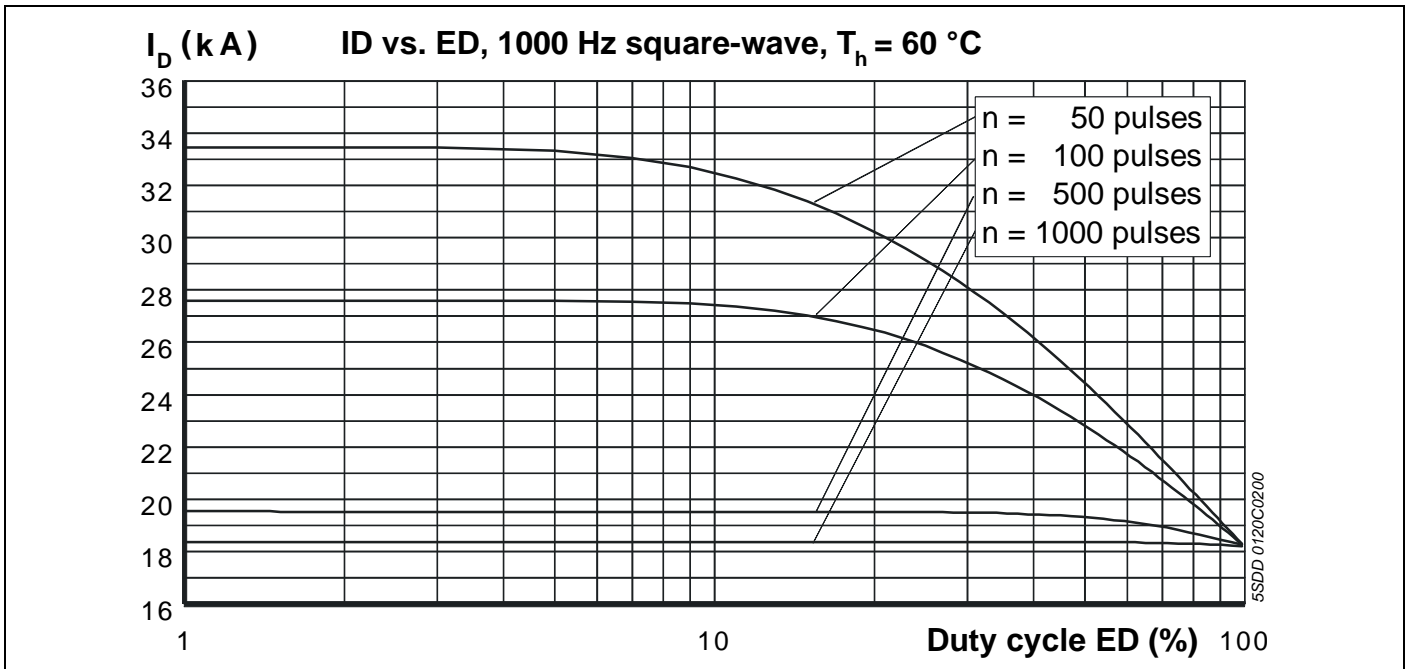
**Fig. 4** Surge current and fusing integral vs. pulse width (max. values) for non-repetitive, half-sinusoidal surge current pulses.

### Current load capability

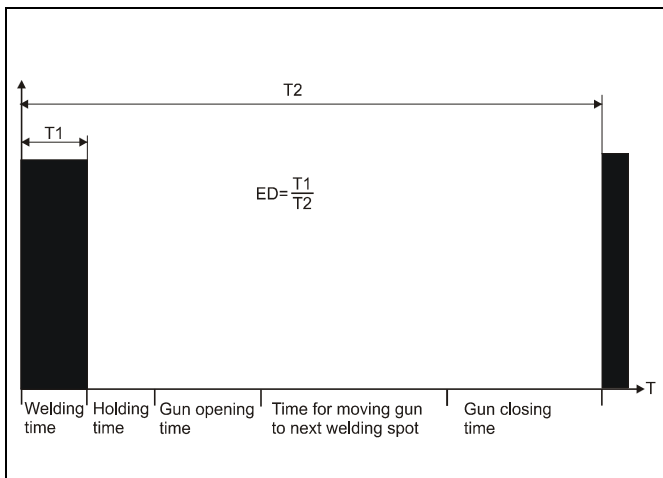


**Fig. 5** DC-output current with single-phase centre tap

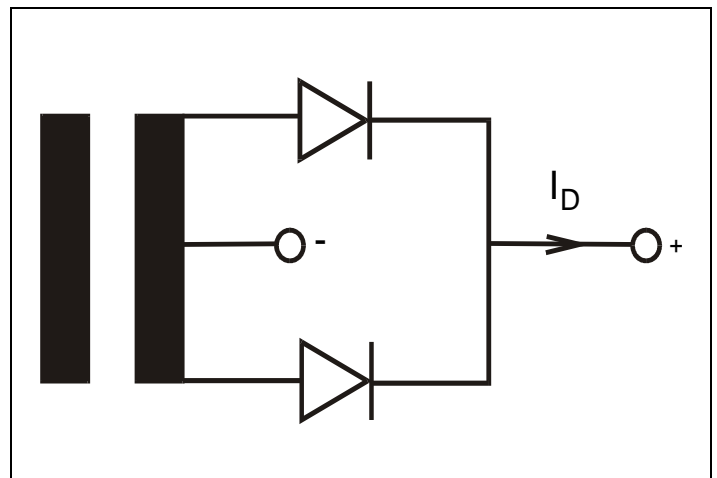
**Current load capacity, cont.**



**Fig. 6** DC-output current with single-phase centre tap



**Fig. 7** Definition of ED for typical welding sequence



**Fig. 8** Definition of ID for single-phase centre tap

ABB Switzerland Ltd, Semiconductors reserves the right to change specifications without notice.



**ABB Switzerland Ltd**  
**Semiconductors**  
**Fabrikstrasse 3**  
**CH-5600 Lenzburg, Switzerland**

Telephone **+41 (0)58 586 1419**  
 Fax **+41 (0)58 586 1306**  
 Email **abbsem@ch.abb.com**  
 Internet **www.abb.com/semiconductors**

Doc. No. 5SYA1157-01 July 06