

SMD ■ MID POWER LED

62-217B/XK2C-SXXXXXXXXXXZ15/2T



Features

- LM-80 Certified
- PLCC-4 Package
- Top view white LED
- High luminous flux output
- High current capability
- Wide viewing angle
- Pb-free
- RoHS compliant
- ANSI Binning

Description

The Everlight 0.5W 62-217B package has high efficacy, high CRI, low power consumption, wide viewing angle and a compact form factor. These features make this package an ideal LED for all lighting application.

Applications

- Decorative and Entertainment Lighting
- Light pipe application
- Indicator and backlight in office and family equipment
- General use

Product Number Explanation

62-217B / XK 2 C - S XX XX XX XX XX Z15/ 2T



Table of Color Rendering Index

Symbol	Description
M	CRI(Min.) : 60
N	CRI(Min.) : 65
L	CRI(Min.) : 70
Q	CRI(Min.) : 75
K	CRI(Min.) : 80
P	CRI(Min.) : 85
H	CRI(Min.) : 90

Notes:
 Tolerance of Color Rendering Index: ±2

Table of Forward Current Index

Symbol	Description
Z15	I _F :150mA

Example:
 62-217B/QK2C-S5757R1R3B42Z15/2T

CRI	75(Min.)
CCT	5700K
Flux	50~65lm
V _F	2.8V~3.5V
I _F	150mA

Mass Production list

Product	CRI Min. ⁽¹⁾	CCT(K)	Φ(lm) Min. ⁽²⁾	Φ(lm) Typ. ⁽²⁾	Φ(lm) Max. ⁽²⁾
62-217B/KK2C-S6565R1R3B42Z15/2T	80	6500K	50	55	65
62-217B/KK2C-S5757QAR3B42Z15/2T	80	5700K	45	50	65
62-217B/KK2C-S5050QAR3B42Z15/2T	80	5000K	45	50	65
62-217B/KK2C-S4040QAR2B42Z15/2T	80	4000K	45	50	60
62-217B/KK2C-S3030PBQAB42Z15/2T	80	3000K	40	45	50
62-217B/KK2C-S3030QAR2B42Z15/2T	80	3000K	45	50	60
62-217B/KK2C-S2727PAQAB42Z15/2T	80	2700K	36	40	50

Mass Production list

Product	CRI Min. ⁽¹⁾	CCT(K)	Φ(lm) Min. ⁽²⁾	Φ(lm) Typ. ⁽²⁾	Φ(lm) Max. ⁽²⁾
62-217B/QK2C-S6565R1R3B42Z15/2T	75	6500K	50	55	65
62-217B/QK2C-S5757QAR1B42Z15/2T	75	5700K	45	50	55
62-217B/QK2C-S5757R1R3B42Z15/2T	75	5700K	50	55	65
62-217B/QK2C-S5050R1R3B42Z15/2T	75	5000K	50	55	65
62-217B/QK2C-S4040QAR1B42Z15/2T	75	4000K	45	50	55

Note:

1. Tolerance of Color Rendering Index: ±2
2. Tolerance of Luminous flux: ±11%.

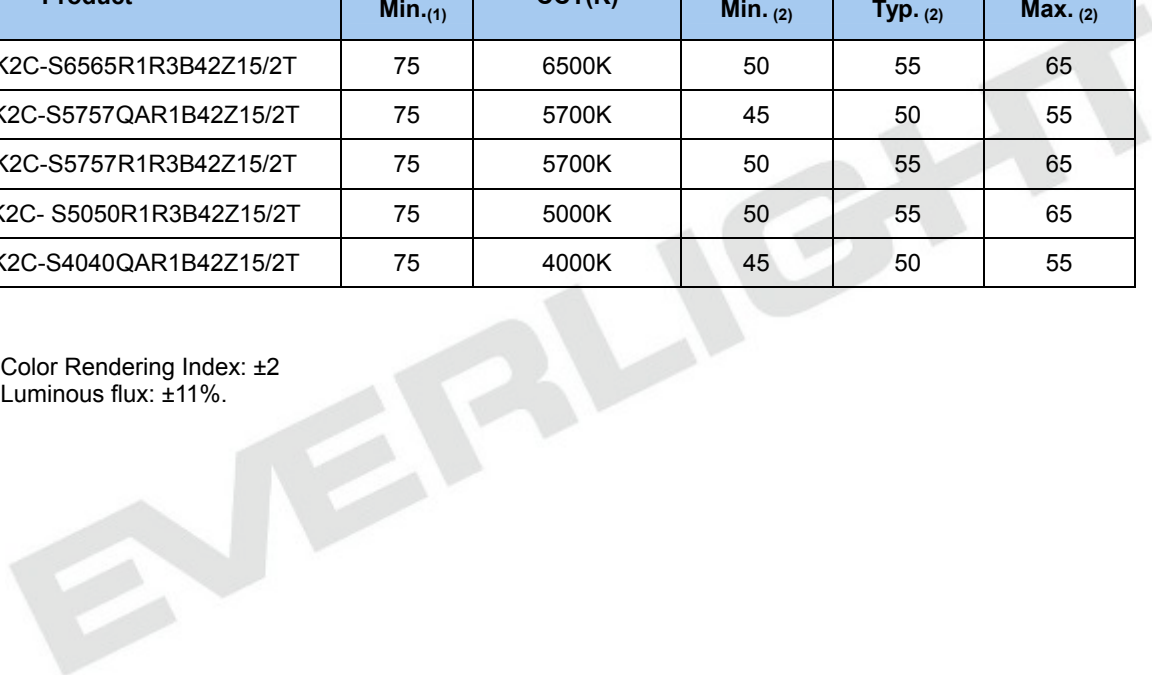

Device Selection Guide

Chip Materials	Emitted Color	Resin Color
InGaN	Cool White Neutral White Warm White	Water Clear

Absolute Maximum Ratings (T_{Soldering}=25)

Parameter	Symbol	Rating	Unit
Forward Current	I _F	180	mA
Peak Forward Current (Duty 1/10 @10ms)	I _{FP}	300	mA
Power Dissipation	P _d	630	mW
Electrostatic Discharge(HBM)	ESD	2000	V
Operating Temperature	T _{opr}	-40 ~ +85	
Storage Temperature	T _{stg}	-40 ~ +100	
Thermal Resistance (Junction / Soldering point)	R _{th J-S}	26	/W
Junction Temperature	T _j	115	
Soldering Temperature	T _{sol}	Reflow Soldering : 260 Hand Soldering : 350	for 10 sec. for 3 sec.

Electro-Optical Characteristics (T_{Soldering}=25)

Parameter	Symbol	Min.	Typ.	Max.	Unit	Condition
Luminous Flux ₍₁₎	Φ	36	-----	65	lm	I _F =150mA
Forward Voltage ₍₂₎	V _F	2.8	-----	3.5	V	I _F =150mA
Color Rendering Index ₍₃₎	2θ _{1/2}	75	-----	-----	-----	I _F =150mA
Viewing Angle	2θ _{1/2}	-----	120	-----	deg	I _F =150mA
Reverse Current	I _R	-----	-----	50	μA	V _R =5V

Notes:

1. Tolerance of Luminous flux: ±11%.
2. Tolerance of Forward Voltage : ±0.1V.
3. Tolerance of Color Rendering Index: ±2

Bin Range of Luminous Flux

Bin Code	Min.	Max.	Unit	Condition
PA	36	40	lm	I _F =150mA
PB	40	45		
QA	45	50		
R1	50	55		
R2	55	60		
R3	60	65		

Notes:
 Tolerance of Luminous flux: ±11%

Bin Range of Forward Voltage

Group	Bin Code	Min.	Max.	Unit	Condition
B42	35	2.8	2.9	V	I _F =150mA
	36	2.9	3.0		
	37	3.0	3.1		
	38	3.1	3.2		
	39	3.2	3.3		
	40	3.3	3.4		
	41	3.4	3.5		

Notes:
 Tolerance of Forward Voltage : ±0.1V.

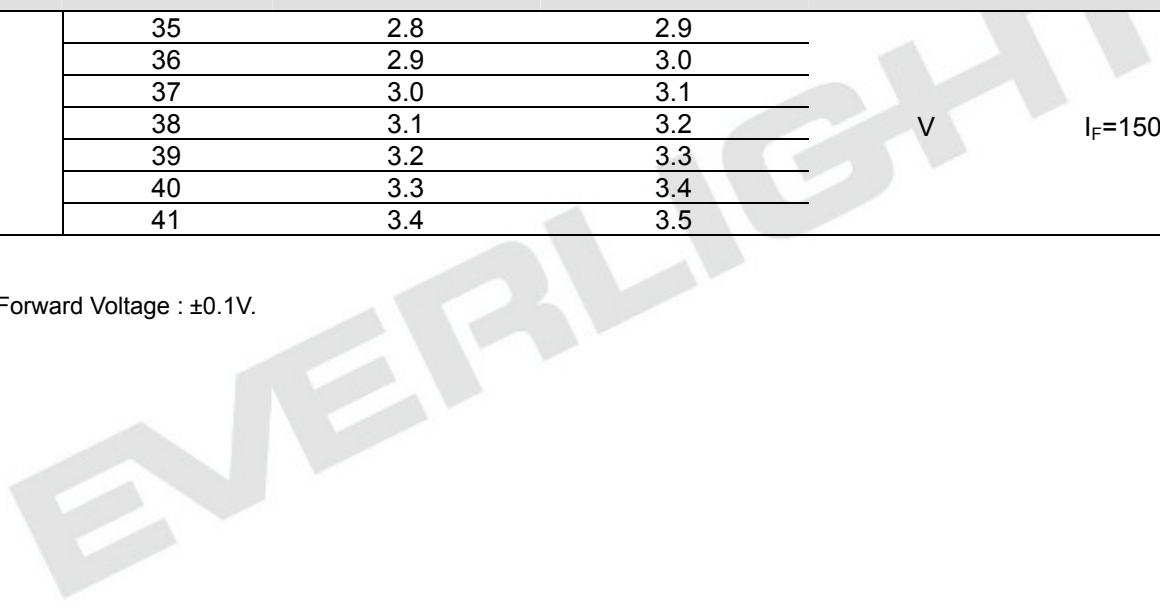

Electro-Optical Characteristics

Warm White

If (mA)	Vf(V)	Power(W)	Flux(lm)	Lm/W
50	2.80	0.14	18.3	130.7
100	2.93	0.29	32.6	112.4
120	3.06	0.37	40.1	109.2
150	3.13	0.47	47.9	102.0
180	3.20	0.58	54.9	95.3

Cool White

If (mA)	Vf(V)	Power(W)	Flux(lm)	Lm/W
50	2.79	0.14	20.2	144.3
100	2.96	0.29	35.3	121.7
120	3.08	0.37	42.8	115.6
150	3.11	0.47	51.3	109.2
180	3.23	0.58	59.5	102.6

Notes:
Data is only for reference..

EVERLIGHT

Bin Range of Chromaticity Coordinate

CCT	Bin Code	CIE_x	CIE_y	Bin Code	CIE_x	CIE_y
6500K	65K-1	0.3205	0.3481	65K-3	0.3131	0.3290
		0.3117	0.3393		0.3048	0.3209
		0.3131	0.3290		0.3068	0.3113
		0.3213	0.3371		0.3145	0.3187
	65K-2	0.3117	0.3393	65K-4	0.3213	0.3371
		0.3028	0.3304		0.3131	0.3290
		0.3048	0.3209		0.3145	0.3187
		0.3131	0.3290		0.3221	0.3261
5700K	57K-1	0.3376	0.3616	57K-3	0.3293	0.3423
		0.3292	0.3539		0.3215	0.3353
		0.3293	0.3423		0.3222	0.3243
		0.3371	0.3493		0.3294	0.3306
	57K-2	0.3292	0.3539	57K-4	0.3371	0.3493
		0.3207	0.3462		0.3293	0.3423
		0.3215	0.3353		0.3294	0.3306
		0.3293	0.3423		0.3366	0.3369
5000K	50K-1	0.3551	0.3760	50K-3	0.3452	0.3558
		0.3464	0.3688		0.3371	0.3493
		0.3452	0.3558		0.3366	0.3369
		0.3533	0.3624		0.3441	0.3428
	50K-2	0.3464	0.3688	50K-4	0.3533	0.3624
		0.3376	0.3616		0.3452	0.3558
		0.3371	0.3493		0.3441	0.3428
		0.3452	0.3558		0.3515	0.3487

Notes:

1. The value are based on driving current by 150mA.
2. Tolerance of Chromaticity Coordinates : ±0.01.

Bin Range of Chromaticity Coordinate

CCT	Bin Code	CIE_x	CIE_y	Bin Code	CIE_x	CIE_y
4000K	40K-1	0.4006	0.4044	40K-3	0.3828	0.3803
		0.3871	0.3959		0.3703	0.3726
		0.3828	0.3803		0.3670	0.3578
		0.3952	0.3880		0.3784	0.3647
	40K-2	0.3871	0.3959	40K-4	0.3952	0.3880
		0.3736	0.3874		0.3828	0.3803
		0.3703	0.3726		0.3784	0.3647
		0.3828	0.3803		0.3898	0.3716
3000K	30K-1	0.4562	0.4260	30K-3	0.4345	0.4033
		0.4431	0.4213		0.4223	0.3990
		0.4345	0.4033		0.4147	0.3814
		0.4468	0.4077		0.4260	0.3854
	30K-2	0.4431	0.4213	30K-4	0.4468	0.4077
		0.4299	0.4165		0.4345	0.4033
		0.4223	0.3990		0.4260	0.3854
		0.4345	0.4033		0.4373	0.3893
2700K	27K-1	0.4813	0.4319	27K-3	0.4585	0.4104
		0.4688	0.4290		0.4468	0.4077
		0.4585	0.4104		0.4373	0.3893
		0.4703	0.4132		0.4483	0.3919
	27K-2	0.4688	0.4290	27K-4	0.4703	0.4132
		0.4562	0.4260		0.4585	0.4104
		0.4468	0.4077		0.4483	0.3919
		0.4585	0.4104		0.4593	0.3944

Notes:

1. The value are based on driving current by 150mA.
2. Tolerance of Chromaticity Coordinates : ±0.01.

The C.I.E. 1931 Chromaticity Diagram

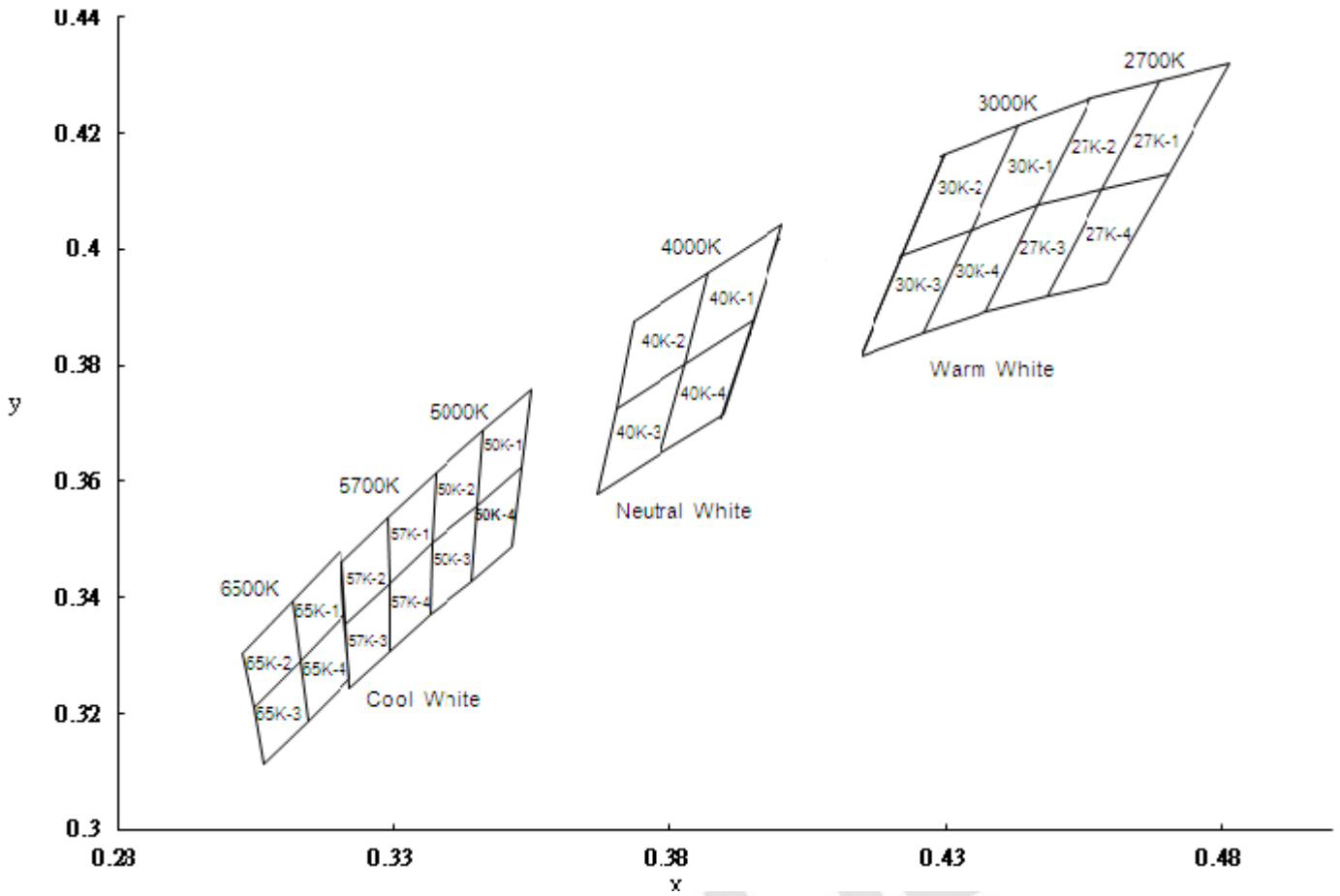

EVERLIGHT

Spectrum Distribution

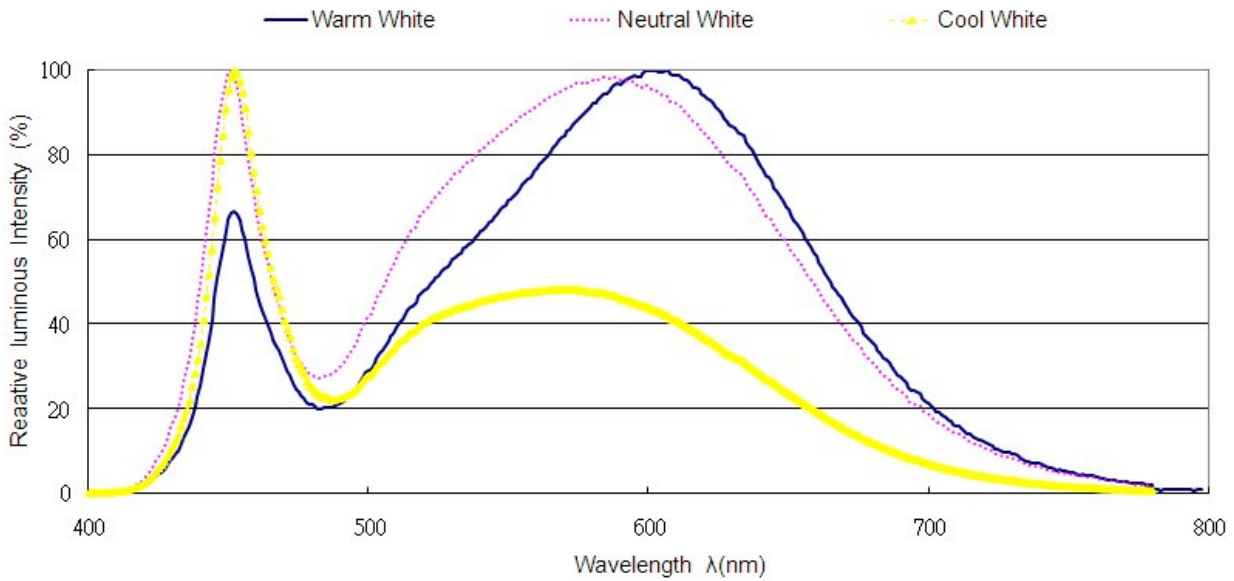

Typical Electro-Optical Characteristics Curves

Fig.1 – Forward Voltage Shift vs. Junction Temperature

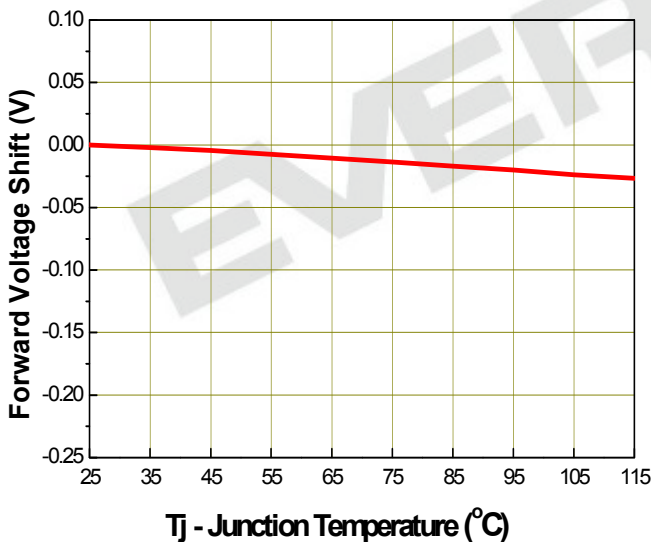
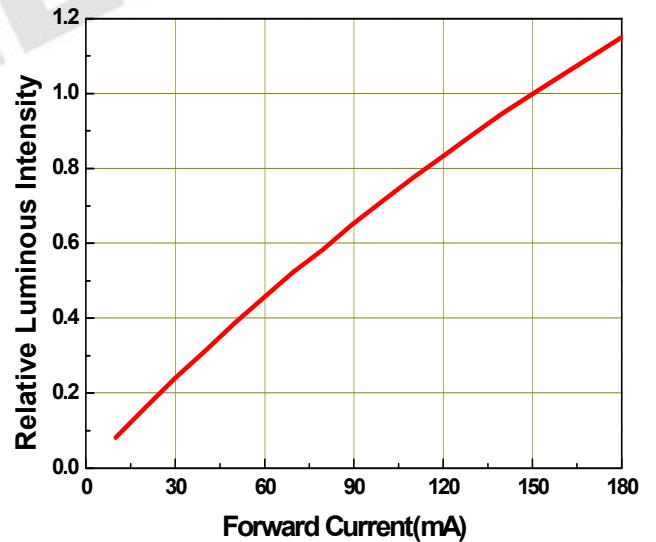

Fig.2 - Relative Luminous Intensity vs. Forward Current



Typical Electro-Optical Characteristics Curves

Fig.3 - Relative Luminous Intensity vs. Junction Temperature

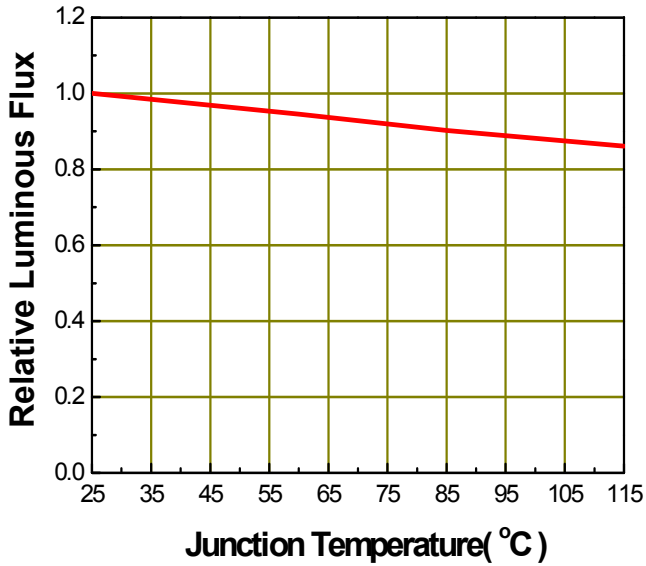

Fig.4 - Forward Current vs. Forward Voltage

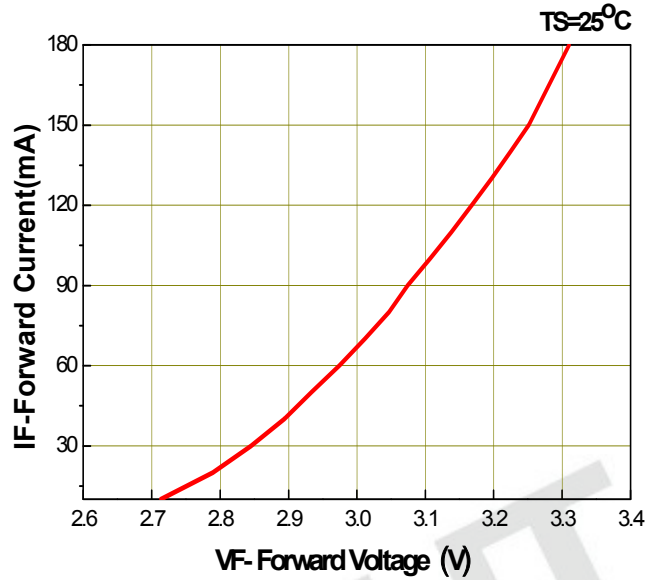

Fig.5 - Max. Driving Forward Current vs. Soldering Temperature

$R_{th\ j-s}=21\ C/W$

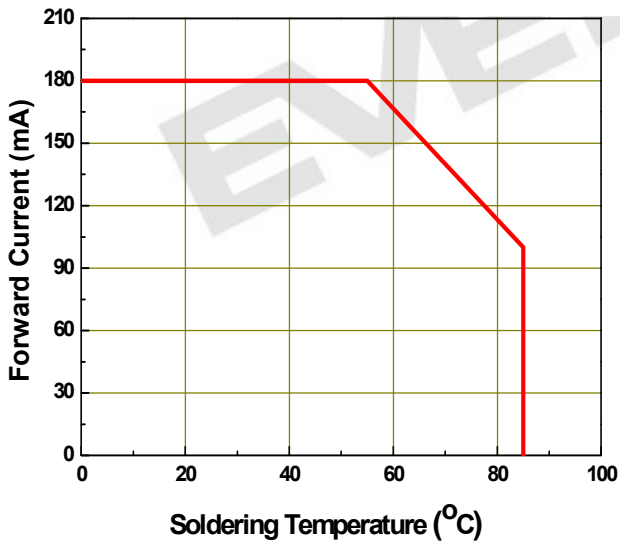
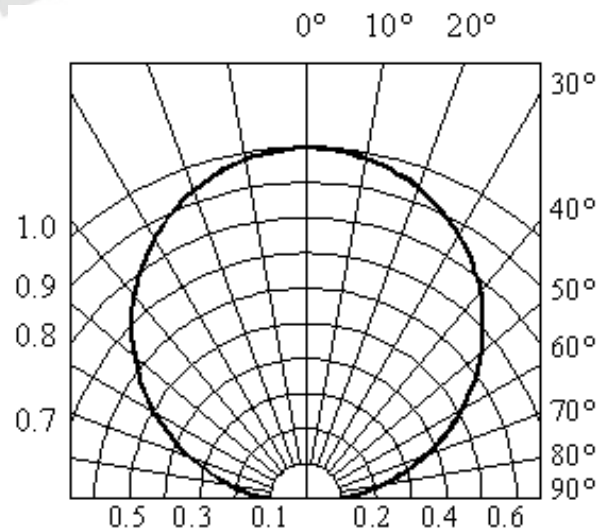
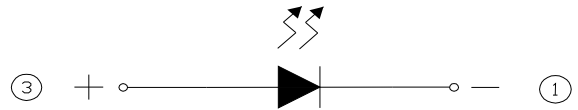
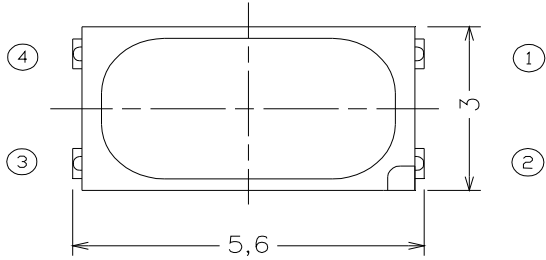

Fig.6 - Radiation Diagram



Package Dimension



Polarity

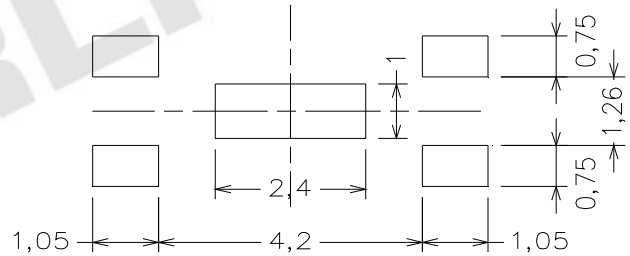
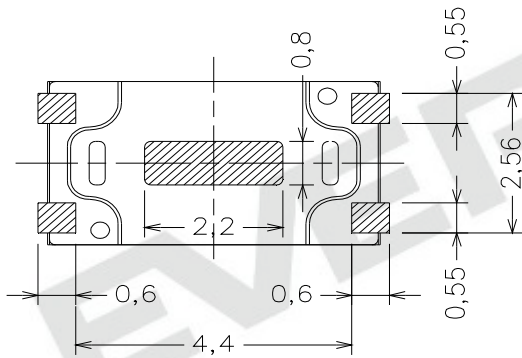
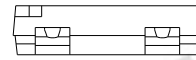
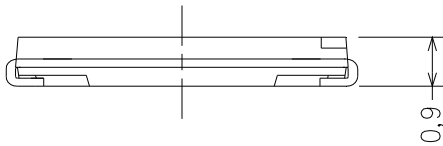

Note:
 Tolerance unless mentioned is $\pm 0.1\text{mm}$; Unit = mm

Moisture Resistant Packing Materials

Label Explanation



- CPN: Customer's Product Number
- P/N: Product Number
- QTY: Packing Quantity
- CAT: Luminous Intensity Rank
- HUE: Dom. Wavelength Rank
- REF: Forward Voltage Rank
- LOT No: Lot Number

Reel Dimensions

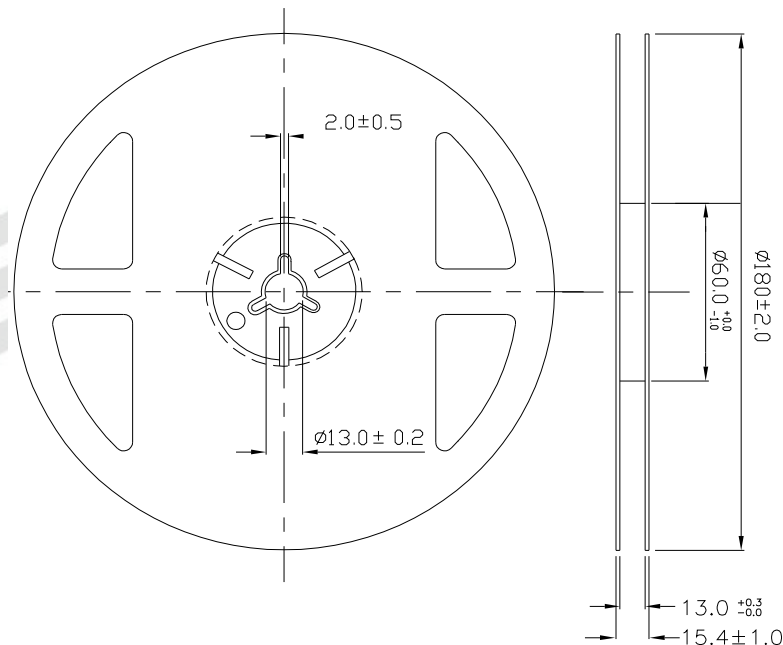

Note:
 Tolerances unless mentioned ± 0.1 mm. Unit = mm

Carrier Tape Dimensions: Loaded Quantity 250/500/1000/2000 pcs. Per Reel

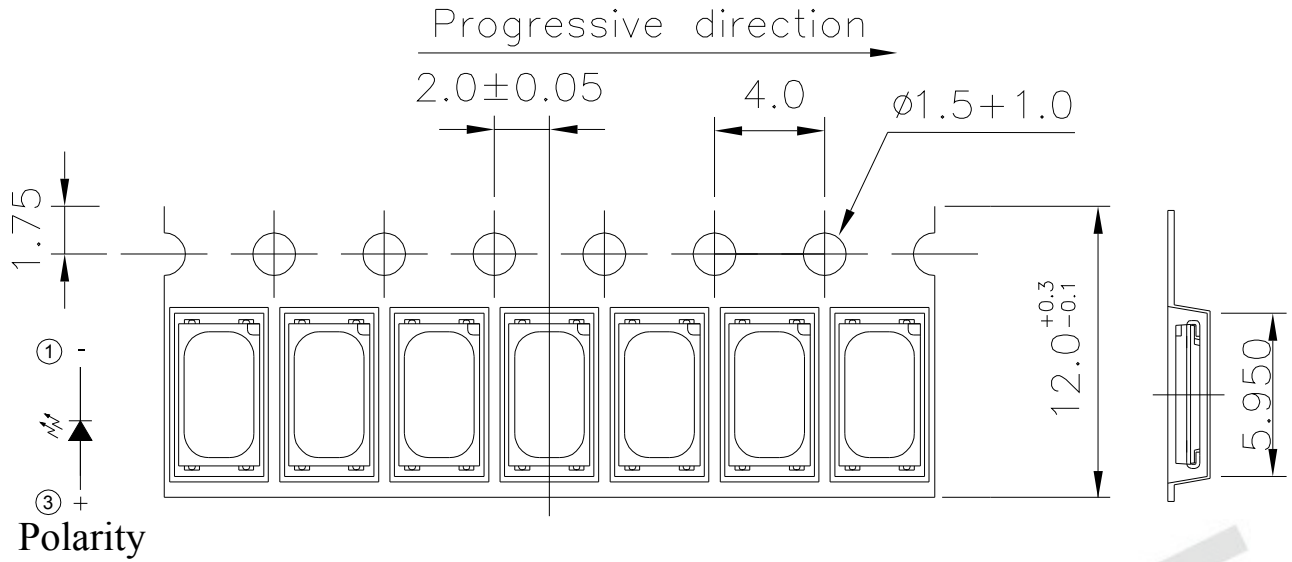

Note:
 1. Tolerance unless mentioned is ± 0.1 mm; Unit = mm

Moisture Resistant Packing Process

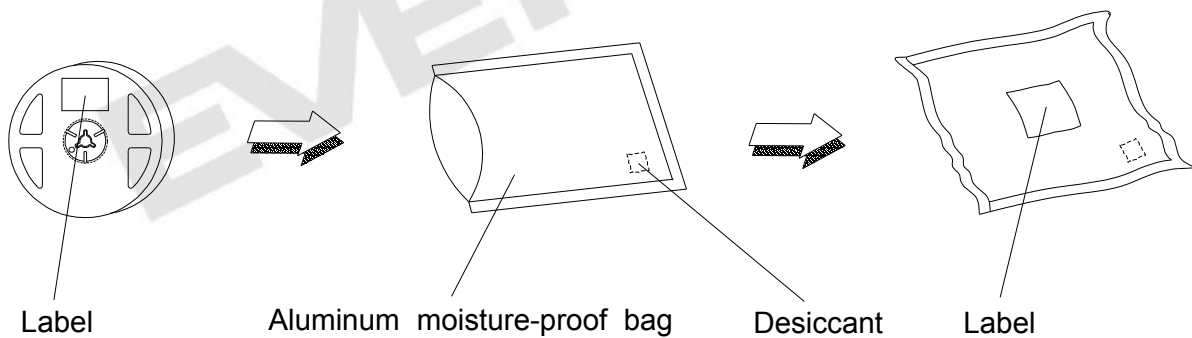

Reliability Test Items and Conditions

The reliability of products shall be satisfied with items listed below.
 Confidence level : 90%
 LTPD : 10%

No.	Items	Test Condition	Test Hours/Cycles	Sample Size	Ac/Re
1	Reflow Soldering	Temp. : 260 /10sec.	6 Min.	22 PCS.	0/1
2	Thermal Shock	H : +100 5min 10 sec L : -10 5min	200 Cycles	22 PCS.	0/1
3	Temperature Cycle	H : +100 15min 5 min L : -40 15min	200 Cycles	22 PCS.	0/1
4	High Temperature/Humidity Storage	Ta=85 ,85%RH	1000 Hrs.	22 PCS.	0/1
5	High Temperature/Humidity Operation	Ta=85 ,85%RH, I _F = 100 mA	1000 Hrs.	22 PCS.	0/1
6	Low Temperature Storage	Ta=-40	1000 Hrs.	22 PCS.	0/1
7	High Temperature Storage	Ta=85	1000 Hrs.	22 PCS.	0/1
8	Low Temperature Operation Life	Ta=-40 , I _F = 150 mA	1000 Hrs.	22 PCS.	0/1
9	High Temperature Operation/ Life#1	Ta=25 , I _F = 150 mA	1000 Hrs.	22 PCS.	0/1
10	High Temperature Operation/ Life#2	Ta=55 , I _F =150 mA	1000 Hrs.	22 PCS.	0/1
11	High Temperature Operation/ Life#3	Ta=85 , I _F = 100 mA	1000 Hrs.	22 PCS.	0/1

Precautions for Use

1. Over-current-proof
Customer must apply resistors for protection; otherwise slight voltage shift will cause big current change (Burn out will happen).
2. Storage
 - 2.1 Do not open moisture proof bag before the products are ready to use.
 - 2.2 Before opening the package: The LEDs should be kept at 30 °C or less and 90%RH or less.
 - 2.3 After opening the package: The LED's floor life is 168 Hrs under 30 °C or less and 60% RH or less. If unused LEDs remain, it should be stored in moisture proof packages.
 - 2.4 If the moisture absorbent material (silica gel) has faded away or the LEDs have exceeded the storage time, baking treatment should be performed using the following conditions.
Baking treatment: 60±5 °C for 24 hours.
3. Soldering Condition
 - 3.1 Pb-free solder temperature profile

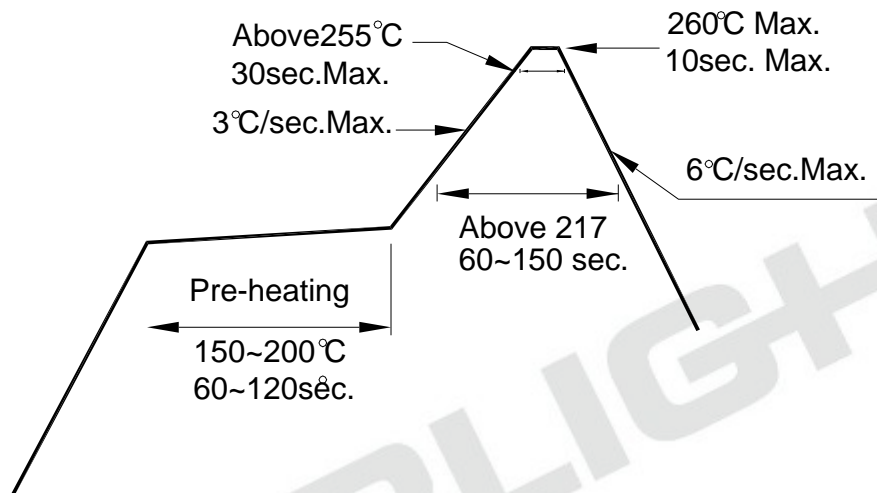

- 3.2 Reflow soldering should not be done more than two times.
- 3.3 When soldering, do not put stress on the LEDs during heating.
- 3.4 After soldering, do not warp the circuit board.

4. Soldering Iron

Each terminal is to go to the tip of soldering iron temperature less than 350 for 3 seconds within once in less than the soldering iron capacity 25W. Leave two seconds and more intervals, and do soldering of each terminal. Be careful because the damage of the product is often started at the time of the hand solder.

5. Repairing

Repair should not be done after the LEDs have been soldered. When repairing is unavoidable, a double-head soldering iron should be used (as below figure). It should be confirmed beforehand whether the characteristics of the LEDs will or will not be damaged by repairing.

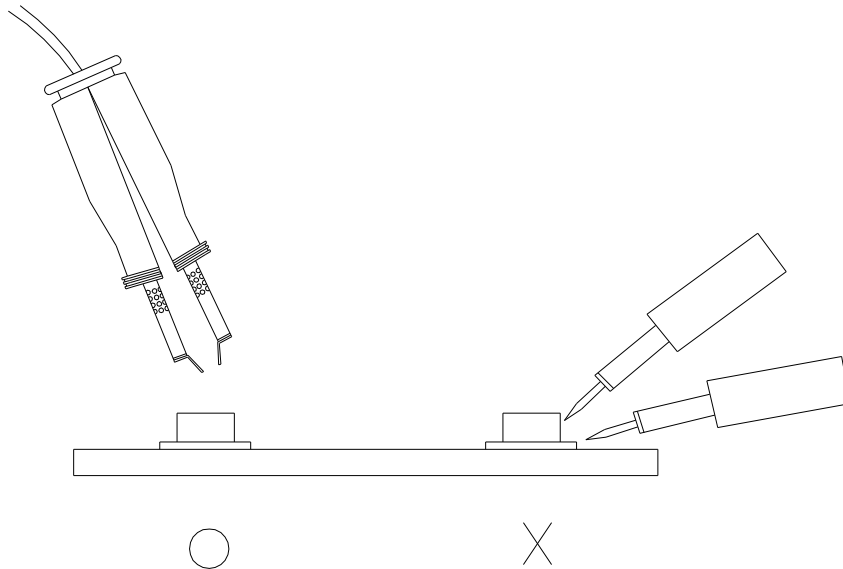



Report No. : HS1208100073A
Version : C

LM-80-08 LUMEN MAINTENANCE TEST REPORT

Company : Everlight Electronics Co., LTD.
Sample Name : 5630
Sample Received : May 8 2012
Sample Tested : Jan 28 2013

TESTING LABORATORY IS ACCREDITED BY:

IEC/IECQ 17025 certificate of independent test laboratory approval
Certificate No. : T1091

ISO 17025 accredited in respect of laboratory is approved by TAF
Certificate No. : L0835-090819

ISO 9001 certificate is approved by TUV CERT certification body of TUV NORD Cert GmbH
EPA-Recognized Laboratories No. : 1112442



WE HEREBY CERTIFY THAT:

The test(s) shown in the attachment were conducted according to the indicating procedures. We assume full responsibility for the accuracy and completeness of these tests and vouch for the qualifications of all personnel performing them.

	Name	Signature	Date
Test Engineer	Max Chen	Max Chen	2013/6/21
Test Manager	Allan Tang	Allan Tang	2013/6/21

Note :

1. This report will be invalid if reproduced in whole or in part.
2. This report refers only to the specimen(s) submitted to test, and is invalid if used separately.
3. This report is ONLY valid with the examination seal and signature of this institute.
4. The tested specimen(s) will only be preserved for thirty days from the date issued, if not collected by the applicant.



Report No. : HS1208100073A
 Version : C

IST LM-80-08 CERTIFICATION

1. EPA Certificate Laboratory (ENERGY STAR® Program)

ENERGY STAR® website:

http://www.energystar.gov/index.cfm?fuseaction=recognized_bodies_list.show_RCB_search_results

→ New Search → Company Name: **Integrated Service Technology**

Organization ID	Organization Name	Type of Recognized Body	If Lab is 1st Party?	Programs	Organization Address	City	State	Country
1112214	Integrated Service Technology Inc. (Tshinchu) ENT CO	Accredited Laboratory	N	Certified Lighting Subcomponents, Luminaires	No 18 Pu Ding Road	Hsin-Chu		TW

2. LED Lighting Facts® Approved Testing Laboratory

Lighting Facts website: <http://www.lightingfacts.com/approvedlabs>

Testing Laboratory Partner	LM-79: total flux and color (required label metrics; LM-79 sections 9 and 12)	LM-79: intensity distribution (optional metrics; LM-79 section 10)	In-situ Temperature Measurement Test (ISTMT)	LM-80
Integrated Service Technology Inc.	No	No	No	9/10/2012 - 9/9/2015

3. EPA Recognized Lab. Accreditation Body

EPA website: http://www.energystar.gov/index.cfm?c=partners.epa_recognized_accreditation_bodies

Taiwan Accreditation Foundation (TAF)

Taiwan

www.taftw.org.tw

4. ISO-17025 Accredited Lab.

TAF (EPA approved Accredited Body) website: <http://hr.taftw.org.tw/service/labinfoE.aspx?code=0835>



Integrated Service Technology Inc.
Reliability & Failure Analysis Engineering Group
1F, No.19, Pu-ding Rd., Hsin - chu City, Taiwan, R.O.C.
Tel: 886-3-578-2288, Fax: 886-3-610-0300
<http://www.istgroup.com>

Report No. : HS120810007SA

Page 2 of 18

1. GENERAL INFORMATION

DESCRIPTION OF TEST UNIT

Manufacturer : Everlight
Model Name : 5630
Nominal CCT : 2700 K
Device Type : LED Package
Package Dimension : 5.6 mm x 3.0 mm
Sample Quantity : See Summary Test Report

2. SUMMARY OF LM-80-08 TEST

2.1 SUMMARY TEST RESULT OF LM-80-08

Date(s) Of Performance Of The Test : May,8,2012 ~ Jan,28,2013

LM-80 Nominal Case Temperature (T_c)	LM-80-08 Specified Temperature		Customer Selected
	55 °C	85 °C	
Test Sample Size (ea)	25	25	25
Test Current (I _f)	150mA	150mA	150 mA
Actual Case Temperature [T_c] $T_c \geq$ Nominal T_c -2 °C	56.4 °C	86.2 °C	45.6 °C
Actual Ambient Temperature [T_a] $T_a \geq$ Nominal T_c -5 °C	54.1 °C	83.9 °C	44.3 °C
Actual Relative Humidity	60 %	60 %	60 %
Avg. CCT at 6,000 hours [K]	2701.2	2696.93	2695.83
Avg. Chromaticity Shift at 6,000 hours	0.0009	0.0011	0.0009
Avg. Lumen Maintenance at 6,000 hours	99.45 %	92.57 %	99.63 %

Based on ENERGY STAR published guidance:

[http://www.energystar.gov/ia/partners/prod_development/new_specs/downloads/luminares/ENERGY STAR Final Lumen Maintenance Guidance.pdf](http://www.energystar.gov/ia/partners/prod_development/new_specs/downloads/luminares/ENERGY_STAR_Final_Lumen_Maintenance_Guidance.pdf)

Lumen maintenance life projection

Table 1: Report at each LM-80 Test Condition					
Description of LED Light Source Tested (manufacturer, model, catalog number)					
Test Condition 1 - 45°C Case Temp		Test Condition 2 - 55°C Case Temp		Test Condition 3 - 85°C Case Temp	
Sample size	25	Sample size	25	Sample size	25
Number of failures	0	Number of failures	0	Number of failures	0
DUT drive current used in the test (mA)	150	DUT drive current used in the test (mA)	150	DUT drive current used in the test (mA)	150
Test duration (hours)	6,000	Test duration (hours)	6,000	Test duration (hours)	6,000
Test duration used for projection (hour to hour)	1,000 - 6,000	Test duration used for projection (hour to hour)	1,000 - 6,000	Test duration used for projection (hour to hour)	1,000 - 6,000
Tested case temperature (°C)	45	Tested case temperature (°C)	55	Tested case temperature (°C)	85
α	2.381E-07	α	1.297E-06	α	1.249E-05
B	0.997	B	1.003	B	1.006
Calculated L70(6k) (hours)	1,486,000	Calculated L70(6k) (hours)	277,000	Calculated L70(6k) (hours)	29,000
Reported L70(6k) (hours)	>36000	Reported L70(6k) (hours)	>36000	Reported L70(6k) (hours)	29,000

