

SMD ■ MID POWER LED

62-227B/XK2C-NXXXXXXXXXXXXXX/2T



Features

- Top view white LED
- High luminous flux output
- High current capability
- White package
- Wide viewing angle
- Pb-free
- RoHS compliant

Description

Due to the package design, 62-227B has wide viewing angle, and white LEDs are devices which are materialized by combing blue chip and special phosphor. This feature makes the LED ideal for light guide application.

Applications

- Decorative and Entertainment Lighting.
- Light pipe application
- Indicator and backlight in office and family equipment
- General use

Product Number Explanation

62-227B / X K 2 C -N XX XX XX XX XX XX / 2T

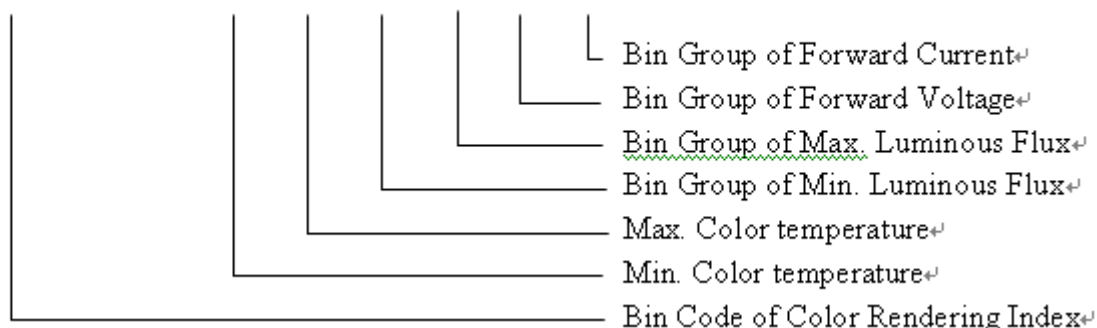

Notes

Table of Color Rendering Index

Symbol	Description
M	CRI(min) : 60
N	CRI(min) : 65
L	CRI(min) : 70
Q	CRI(min) : 75
K	CRI(min) : 80
H	CRI(min) : 90

Notes:

1. Tolerance of Color Rendering Index: ±2

Table of Forward Current Index

Symbol	Description
Z6	I _F :60mA
Z12	I _F :120mA

Example:

62-227B/LK2C-N5757P3P4S2Z6/2T

CRI	Min=70
CCT	5700K
Flux	33~45lm
VF	5.8V~7.0V
I _F	60mA

Mass Production list

Product	CRI min.	CCT(K)	IV(mcd) Min	IV(mcd) Max	Φ(lm) Typ.
62-227B/LK2C-N5757P3P4S2Z6/2T	70	5700K	33	39	45
62-227B/LK2C-N4040N4P3S2Z6/2T	70	4000K	27	35	39
62-227B/LK2C-N3030N4P3S2Z6/2T	70	3000K	27	33	39
62-227B/KK2C-N4040N4P3S2Z6/2T	80	4000K	27	33	39
62-227B/KK2C-N3030N4P3S2Z6/2T	80	3000K	27	31	39

Device Selection Guide

Chip Materials	Emitted Color	Resin Color
InGaN	Cool White Neutral White Warm White	Water Clear

Absolute Maximum Ratings (Ta=25°C)

Parameter	Symbol	Rating	Unit
Reverse Voltage*1	V _R	10	V
Forward Current*1	I _F	100	mA
Peak Forward Current (Duty 1/10 @10ms) *1	IFP	300	mA
Power Dissipation*1	Pd	350	mW
Electrostatic Discharge(HBM)*1	ESD	1000	V
Operating Temperature	Topr	-40 ~ +85	°C
Storage Temperature	Tstg	-40 ~ +90	°C
Soldering Temperature	T _{sol}	Reflow Soldering : 260 °C for 10 sec. Hand Soldering : 350 °C for 3 sec.	

- * 1. The value are based on single die
- 2. The products are sensitive to static electricity and must be carefully taken when handling products.

Electro-Optical Characteristics (Ta=25°C)

Parameter	Symbol	Min.	Typ.	Max.	Unit	Condition
Viewing Angle	2θ _{1/2}	-----	120	-----	deg	I _F =60mA ^{*1}
Reverse Current	I _R	-----	-----	50	µA	V _R =5V ^{*1}

1. *1 For each LED package.

Bin Range of Luminous Flux

Bin Code	Min.	Max.	Unit	Condition
N3	24	27	lm	$I_F=60mA^{*1}$
N4	27	33		
P3	33	39		
P4	39	45		
Q3	45	52		

Notes:

- *1 For each LED package
- Tolerance of Luminous flux: $\pm 11\%$

Bin Range of Forward Voltage

Group	Bin Code	Min.	Max.	Unit	Condition
S2	5#8	5.80	5.90	v	$I_F=60mA^{*1}$
	5#9	5.90	6.00		
	6#0	6.00	6.10		
	6#1	6.10	6.20		
	6#2	6.20	6.30		
	6#3	6.30	6.40		
	6#4	6.40	6.50		
	6#5	6.50	6.60		
	6#6	6.60	6.70		
	6#7	6.70	6.80		
	6#8	6.80	6.90		
6#9	6.90	7.00			

Notes:

- *1 For each LED package
- Tolerance of Forward Voltage $\pm 0.05V$

Bin Range of Chromaticity Coordinates

CCT	Bin Code	CIE_x	CIE_y	Bin Code	CIE_x	CIE_y
5700K	57K-A	0.3292	0.3600	57K-C	0.3172	0.3310
		0.3420	0.3700		0.3293	0.3423
		0.3410	0.3530		0.3294	0.3306
		0.3293	0.3423		0.3183	0.3210
	57K-B	0.3153	0.3500	57K-D	0.3410	0.3530
		0.3292	0.3600		0.3293	0.3423
		0.3293	0.3423		0.3294	0.3306
		0.3172	0.3310		0.3403	0.3380
4000K	40K-A	0.4006	0.4044	40K-C	0.3828	0.3803
		0.3871	0.3959		0.3703	0.3726
		0.3828	0.3803		0.3670	0.3578
		0.3952	0.3880		0.3784	0.3647
	40K-B	0.3871	0.3959	40K-D	0.3952	0.3880
		0.3736	0.3874		0.3828	0.3803
		0.3703	0.3726		0.3784	0.3647
		0.3828	0.3803		0.3898	0.3716
3000K	30K-A	0.4562	0.4260	30K-C	0.4345	0.4033
		0.4431	0.4213		0.4223	0.3990
		0.4345	0.4033		0.4147	0.3814
		0.4468	0.4077		0.4260	0.3854
	30K-B	0.4431	0.4213	30K-D	0.4468	0.4077
		0.4299	0.4165		0.4345	0.4033
		0.4223	0.3990		0.4260	0.3854
		0.4345	0.4033		0.4373	0.3893

Note:
 Tolerance of Chromaticity Coordinates: ±0.01

The C.I.E. 1931 Chromaticity Diagram

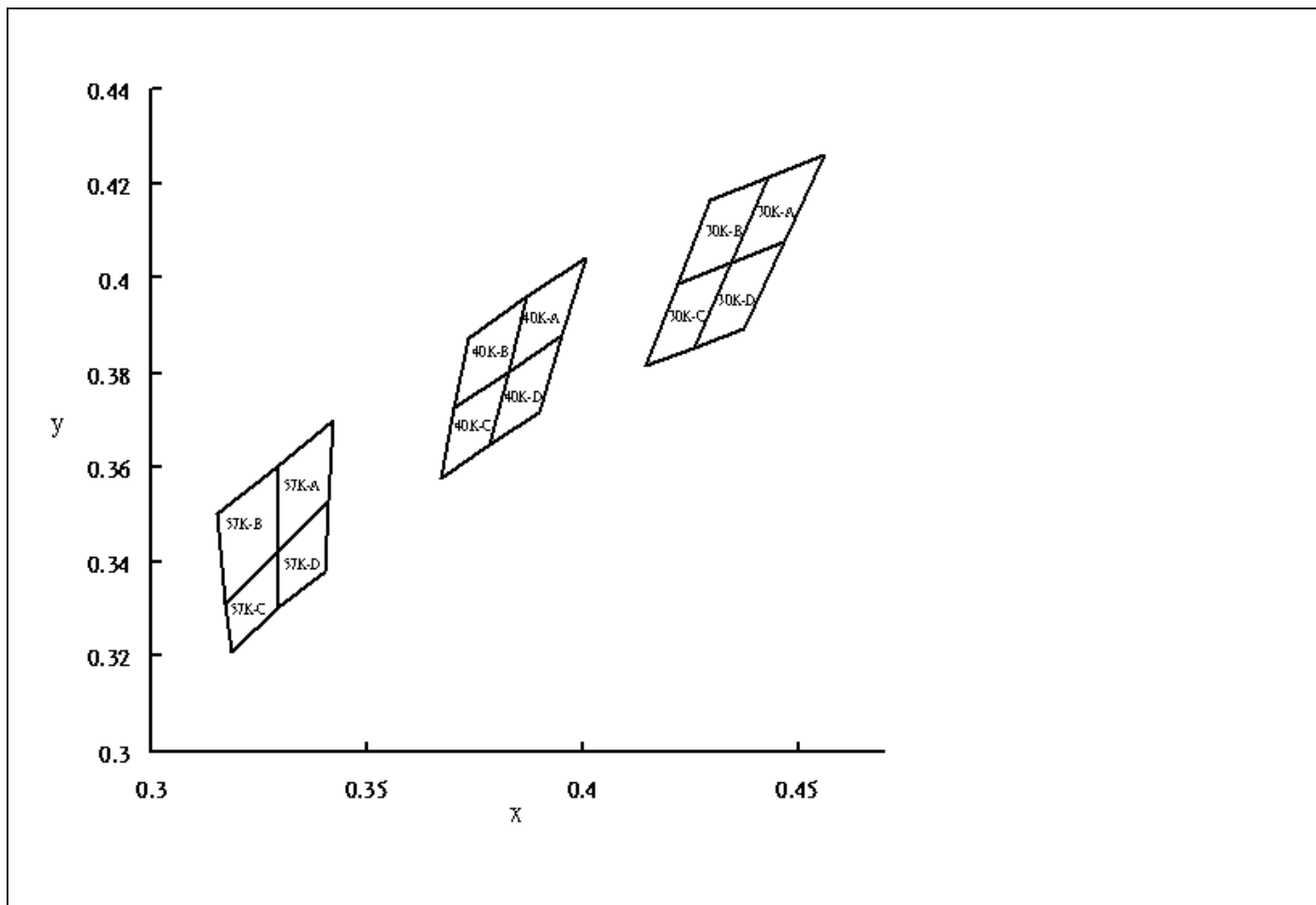

Typical Electro-Optical Characteristics Curves

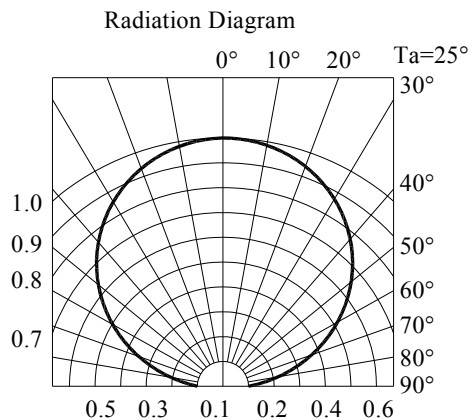
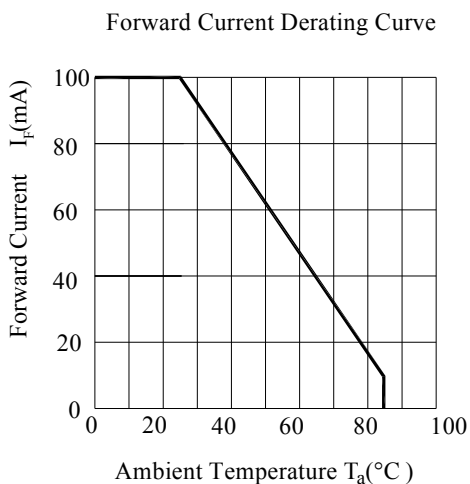
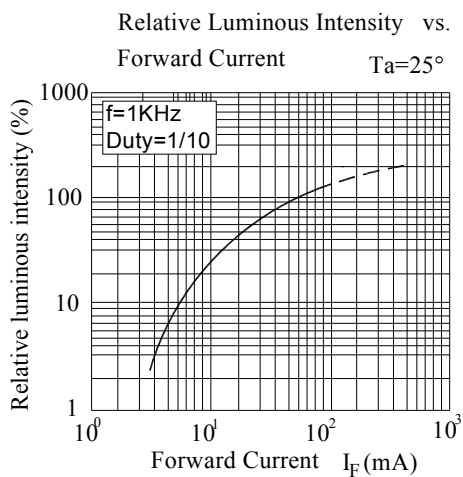
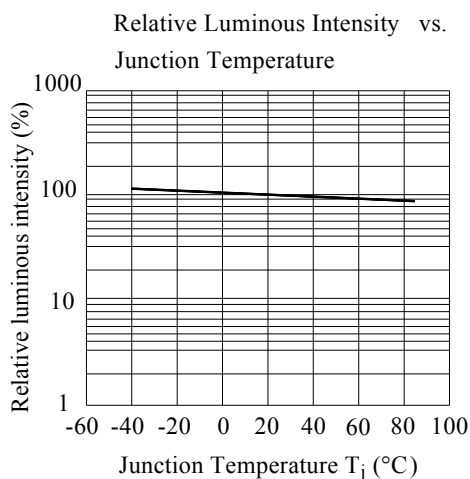
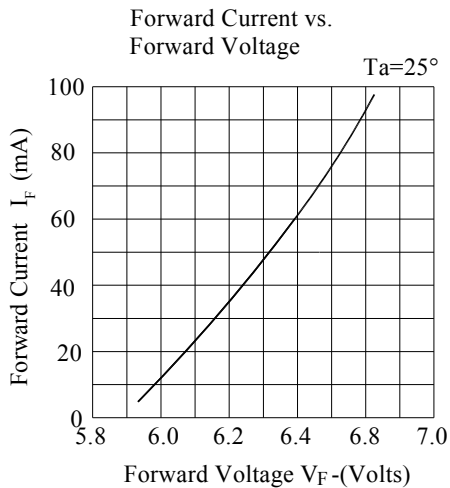
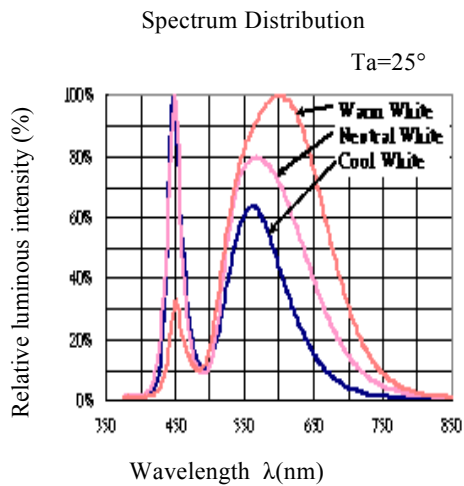

Package Dimension

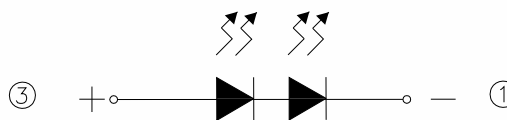
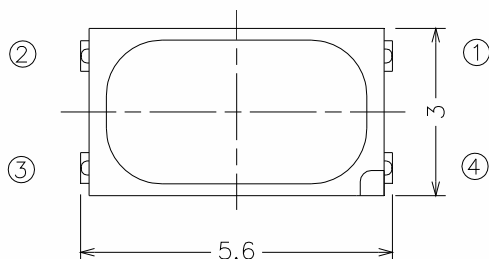

Polarity

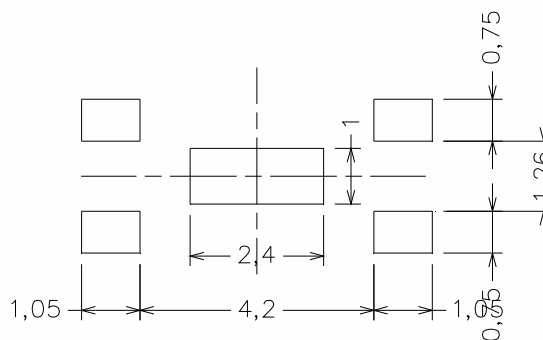
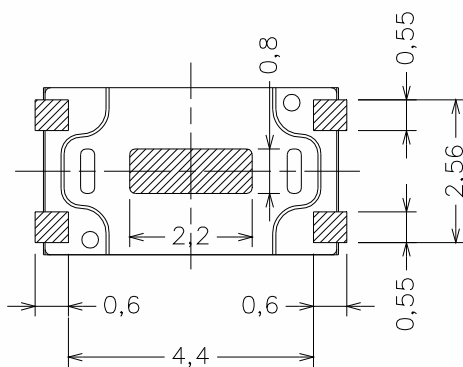
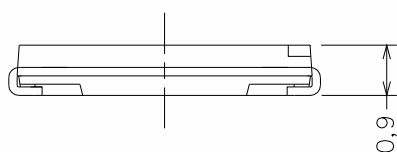

Note:
 Tolerance unless mentioned is $\pm 0.1\text{mm}$; Unit = mm

Moisture Resistant Packing Materials

Label Explanation



- CPN: Customer's Product Number
- P/N: Product Number
- QTY: Packing Quantity
- CAT: Luminous Intensity Rank
- HUE: Dom. Wavelength Rank
- REF: Forward Voltage Rank
- LOT No: Lot Number

Reel Dimensions

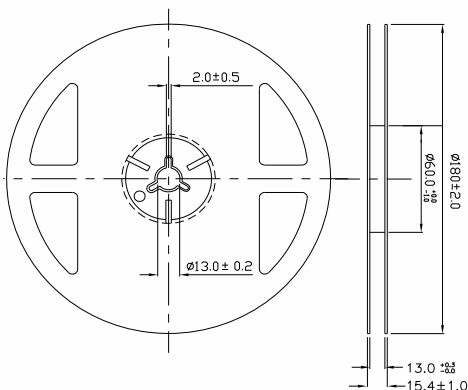

Carrier Tape Dimensions: Loaded Quantity 2000 pcs Per Reel

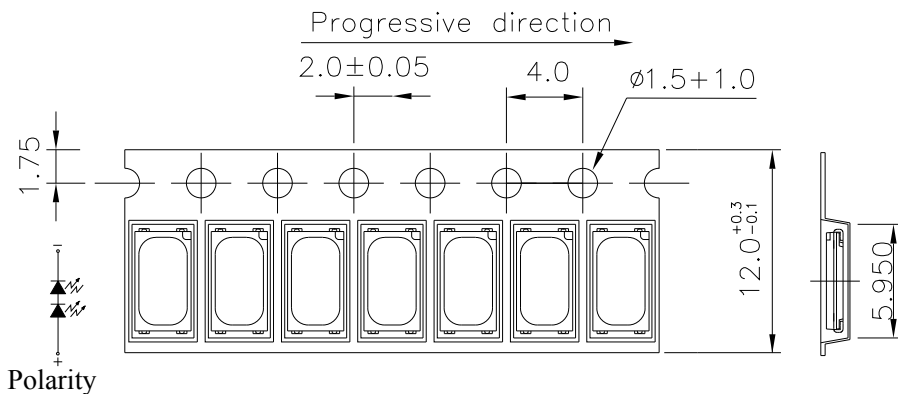

Note:
 Tolerances unless mentioned ±0.1mm. Unit = mm

Moisture Resistant Packing Process

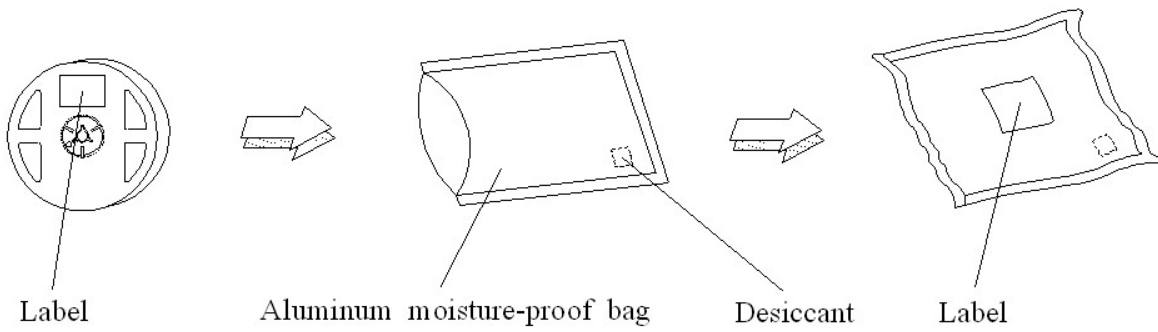

Note:
Tolerances unless mentioned $\pm 0.1\text{mm}$. Unit = mm

Precautions for Use

1. Over-current-proof

Customer must apply resistors for protection; otherwise slight voltage shift will cause big current change (Burn out will happen).

2. Storage

2.1 Do not open moisture proof bag before the products are ready to use.

2.2 Before opening the package: The LEDs should be kept at 30°C or less and 90%RH or less.

2.3 After opening the package: The LED's floor life is 72 Hrs under 30°C or less and 60% RH or less. If unused LEDs remain, it should be stored in moisture proof packages.

2.4 If the moisture absorbent material (silica gel) has faded away or the LEDs have exceeded the storage time, baking treatment should be performed using the following conditions.

Baking treatment: 60±5°C for 24 hours.

3. Soldering Condition

3.1 Pb-free solder temperature profile

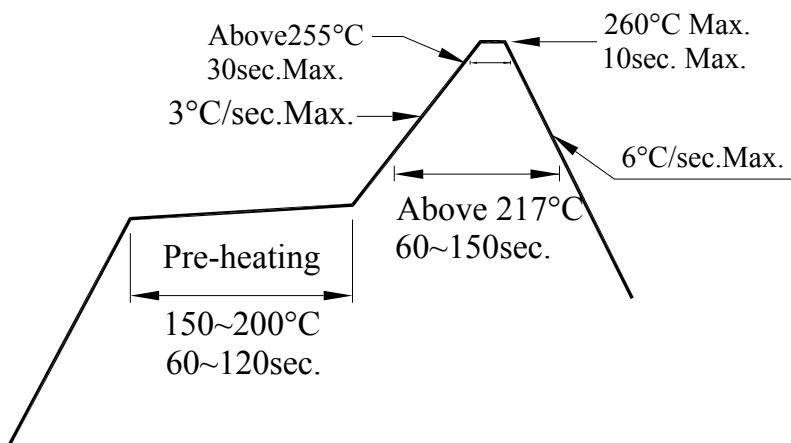

3.2 Reflow soldering should not be done more than two times.

3.3 When soldering, do not put stress on the LEDs during heating.

3.4 After soldering, do not warp the circuit board.

4. Soldering Iron

Each terminal is to go to the tip of soldering iron temperature less than 350°C for 3 seconds within once in less than the soldering iron capacity 25W. Leave two seconds and more intervals, and do soldering of each terminal. Be careful because the damage of the product is often started at the time of the hand solder.

5. Repairing

Repair should not be done after the LEDs have been soldered. When repairing is unavoidable, a double-head soldering iron should be used (as below figure). It should be confirmed beforehand whether the characteristics of the LEDs will or will not be damaged by repairing.

